

1 Introduction and Parameter Settings

1.1 Introduction

1.1.1 Introduction

This application note is meant to be a guideline for using Danfoss VLT Aqua Drive in closed loop applications which allows the pump/fan to be stopped for a period of time depending on the demand. The idea is to make an easy guideline of how to commission the VLT® AQUA Drive.

1.1.2 Application description

The system used as an example is a pump application, where the pump can be stopped in a low demand period in order to reduce energy consumption.

In Danfoss we call it sleep mode.

In VLT® AQUA Drive sleep mode can be entered in two ways. It can be based on a low speed detection, where the closed loop simply runs the drive at minimum speed for a user specified time, where-after the drive enters sleep mode and waits for a wake up signal, which is the difference in % to the set-point defined by the user. Or it can be based on a low flow / low power detection, where the drive simply compares the current power at the current speed with a power curve set up in the drive at commissioning. The first one is the most simple and the second option will monitor the flow demand at all speeds.

The application note describes an example including installation diagram, all needed parameters and typical settings.

1.1.3 Example

In the example below the application considered is a water boost pump including a 4-20 mA pressure transducer with a pressure range of 0-10 bar controlled in closed loop and maintaining a set-point of 4 bar. The pressure transmitter is connected to the second analogue input terminal 54 in order to make commissioning with the Quick Menu possible and easy . (Using analogue input 54 for feedback is recommended for all closed loop applications, since most needed settings then will be default and available in the Quick Menu):

1.1.4 Electrical wiring

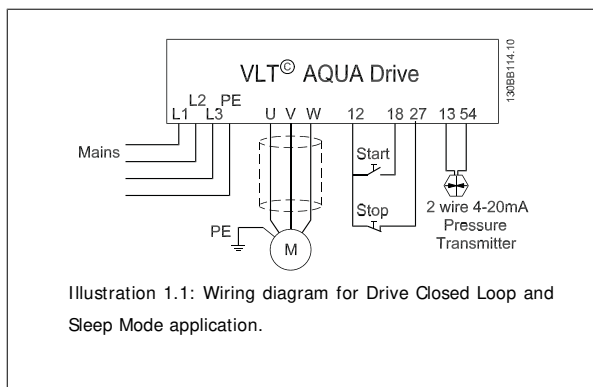

Please set analogue input 2, (terminal 54) format to [mA]. (Switch 202)

1

1.2 Parameter settings

1.2.1 General settings

General settings:	Parameter	Typical settings
Change display language	0-01	
Set motor speed unit (RPM/Hz)	0-02	Hz

1.2.2 Motor data

Motor data:	Parameter	Typical settings
Motor rated power (kW/HP)	1-20 / 1-21	
Motor rated Voltage	1-22	
Motor current	1-24	
Motor rated speed	1-25	
Enable Automatic Motor Adaptation (AMA)	1-29	

1.2.3 Display settings

The display can be set up to show 5 different variables. The variables can be changed in par. 0-2* but by default it will show set-point, current, frequency and feedback.

1.2.4 References

References:	Parameter	Typical settings
Min reference	3-01	30Hz
Max reference	3-02	50/60Hz
Normal ramp up time	3-41	8 sec.* depending on size
Normal ramp down time	3-42	8 sec.* depending on size

1.2.5 Limits

Limits:	Parameter	Typical settings
Motor min speed	4-12	30 Hz
Motor Max speed	4-14	50/60 Hz

1.2.6 Closed loop settings

When looking for an easy way to set-up closed loop, it is an advantage to use the closed loop wizard found under "Quick Menus>Function Setups" or by using the following data from Main menu.

Closed loop settings:	Parameter	Typical settings
Change from open to closed loop operation	1-00	(closed loop)
Feedback unit	20-12	(Bar, PSI, etc)
Low scaling value of feedback	6-24	(0 Bar) Match the transducer range
High scaling value of feedback	6-25	(10 Bar) Match the transducer range
PID settings		
Choose normal or inverse control	20-81	(Inverse = level control)
Choose PID start speed	20-83	(30 Hz)
Set point	20-21	(ex. 6 Bar)

The PID gain and integral time can be set in par. 20-93 and par. 20-94. Alternatively these can be auto-tuned for maximum performance by the following steps.

Please note PI Auto-tune must be enabled from the LCP. No access possible from MCT10.

The PI auto-tune parameters are located found in par. 20-7* .

For many application default values it is sufficient, but the following parameters are recommended to consider before carrying out the PI auto-tune.

Closed loop settings:	Parameter	Typical settings
Closed loop type	20-70	(fast or slow reacting system)
Max output change during auto tune	20-72	(default +/-10%)
Min allowable feedback level	20-73	(in critical systems the auto tune will stop, if the feedback falls below this level in units)
Max allowable feedback	20-74	(Same as par. 20-73, just max level)
Enable auto tune	20-79	
Follow the steps shown in the display		

After auto tune is completed you can accept the calculated values or cancel. If you accept the system will be ready to run in closed loop.

1.2.7 Sleep mode

In systems with varying demands the pump may be stopped during low flow periods in order save energy.

1.2.8 Sleep mode based on low speed detection

Sleep mode settings:	Parameter	Typical settings
Enable low speed detection	22-22	
Choose function at low speed	22-23	(Sleep mode)
Choose low speed delay	22-24	(the time running on low speed before entering sleep mode)
Set up wake up feedback level in % from set-point	22-44	(10% will wake up the drive when the feedback is 10% below the set point)

With the settings above, Sleep Mode will be activated when the pump is running at motor minimum speed as set in par. 22-24.

NB!

In SW version 1.31 or higher, it is possible to choose a sleep speed different from the motor minimum speed by setting the speed in par. 22-29.

1.2.9 Boost mode

The drive can be set up to boost the pressure before entering sleep mode in order to let the drive be stopped for a longer time period. To be used in constant pressure systems.

Sleep mode settings:	Parameter	Typical settings
Set the pressure at which the pressure can be increased in % of set point	22-45	-
Set the maximum boost time, the drive can be allowed to boost the pressure	22-46	-