

**VACON<sup>®</sup> NXS/P**  
AC DRIVES

**USER MANUAL**  
**WALL-MOUNTED DRIVES**  
**STANDALONE DRIVES**

**VACON<sup>®</sup>**



# PREFACE

Document ID:           DPD00910F

Date:                   13.1.2017

## ABOUT THIS MANUAL

This manual is copyright of Vacon Ltd. All Rights Reserved. The manual is subject to change without prior notice. The original language of these instructions is English.

The User Manual gives you the necessary information about the installation, commissioning and operation of VACON® NX AC drives. We recommend that you read carefully these instructions before the first power-up of the AC drive.

For information on the parameters, see the VACON® NX All-in-One Application Manual. You can download the manual from <http://drives.danfoss.com/knowledge-center/technical-documentation/>.

## START-UP QUICK GUIDE

Do at minimum these 10 procedures during the installation and commissioning.

If you have problems, speak to the distributor near you.

1. Do a check that the delivery agrees to your order, see Chapter 3 *Receiving the delivery*.
2. Before you start the commissioning, read carefully the safety instructions in Chapter 2 *Safety*.
3. Before the mechanical installation, do a check of the minimum clearances around the AC drive (Chapter 4 *Mounting*) and do a check of the ambient conditions in Chapter 9.2 *VACON® NXS and NXP - technical data*.
4. Do a check of the dimensions of the motor cable, mains cable, mains fuses and do a check of the cable connections. Read Chapters 5.1 *Cable connections* to 5.3 *Cable dimensioning and selection*.
5. Obey the installation instructions, see Chapter 5.7 *Cable installation*.
6. Find information on the control connections in Chapter 6.2.2 *Control terminals on OPTA1*.
7. If the Start-Up wizard is active, select the language of the keypad and the application. Accept the selections with the Enter button. If the Start-Up wizard is not active, obey the instructions a and b.
  - a) Select the language of the keypad from the Menu M6, page 6.1. For instructions on how to use the keypad, see Chapter 7 *Control panel*.
  - b) Select the application from the Menu M6, page 6.2. For instructions on how to use the keypad, see Chapter 7 *Control panel*.
8. All parameters have factory default values. To make sure that the AC drive operates correctly, make sure that these group G2.1 parameters have the same data as the nameplate. For more information on the parameters in the list below, see the VACON® All in One Application Manual.
  - nominal voltage of the motor
  - nominal frequency of the motor
  - nominal speed of the motor
  - nominal current of the motor
  - motor cos phi
9. Obey the commissioning instructions, see Chapter 8 *Commissioning and additional instructions*.
10. The VACON® NXS or NXP AC drive is ready for operation.

Vacon Ltd is not responsible if you use the AC drives against the instructions.

# TABLE OF CONTENTS

## Preface

About this manual .....	3
-------------------------	---

## Start-up Quick Guide

<b>1 Approvals .....</b>	<b>8</b>
<b>2 Safety .....</b>	<b>10</b>
2.1 The safety symbols used in the manual .....	10
2.2 Warning .....	10
2.3 Caution .....	11
2.4 Grounding and earth fault protection .....	12
2.5 Using an RCD or an RCM device .....	13
<b>3 Receiving the delivery .....</b>	<b>14</b>
3.1 Package label .....	14
3.2 Type designation code .....	15
3.3 Storage .....	18
3.4 Removing the packaging and lifting the AC drive .....	18
3.4.1 Weight of the AC drive .....	18
3.5 Accessories .....	19
3.5.1 FR4-FR6 cable accessories .....	19
3.5.2 FR7-FR8 cable accessories .....	22
3.6 "Product modified" label .....	25
3.7 Disposal .....	25
<b>4 Mounting .....</b>	<b>26</b>
4.1 General information about mounting .....	26
4.2 Dimensions for wall mounting .....	27
4.2.1 Wall mounting of FR4-FR6 .....	27
4.2.2 Wall mounting of FR7 .....	28
4.2.3 Wall mounting of FR8 .....	29
4.2.4 Wall mounting of FR9 .....	30
4.3 Dimensions for flange mounting .....	31
4.3.1 Flange mounting of FR4 to FR6 .....	31
4.3.2 Flange mounting of FR7 and FR8 .....	33
4.3.3 Flange mounting of FR9 .....	35
4.4 Dimensions for standalone .....	36
4.4.1 Standalone (FR10 and FR11) .....	36
4.5 Cooling .....	36
4.5.1 Cooling of FR4 to FR9 .....	37
4.5.2 Cooling of standalone AC drives (FR10 to FR11) .....	39
4.6 High altitude installations .....	40
<b>5 Power cabling .....</b>	<b>42</b>
5.1 Cable connections .....	42
5.2 UL standards on cabling .....	44

5.3	Cable dimensioning and selection .....	44
5.3.1	Cable and fuse sizes for 208-240 V and 380-500 V, FR4 to FR9 .....	45
5.3.2	Cable and fuse sizes for 525-690 V, FR6 to FR9 .....	47
5.3.3	Cable and fuse sizes for 380-500 V, FR10 to FR11 .....	49
5.3.4	Cable and fuse sizes for 525-690 V, FR10 to FR11 .....	50
5.4	Understanding the power unit topology .....	51
5.5	Brake resistor cables .....	51
5.6	Preparing for the cable installation .....	52
5.7	Cable installation .....	52
5.7.1	Enclosure sizes FR4 to FR7 .....	52
5.7.2	Enclosure sizes FR8 to FR9 .....	58
5.7.3	Enclosure sizes FR10-FR11 .....	63
<b>6</b>	<b>Control unit .....</b>	<b>64</b>
6.1	Control voltage (+24V/EXT +24V) .....	64
6.2	Control unit cabling .....	65
6.2.1	Selection of the control cables .....	65
6.2.2	Control terminals on OPTA1 .....	65
6.2.3	Control terminals on OPTA2 and OPTA3 .....	69
6.3	Installation of option boards .....	70
6.4	Galvanic isolation barriers .....	70
<b>7</b>	<b>Control panel .....</b>	<b>71</b>
7.1	Control keypad .....	71
7.2	Display .....	72
7.3	Navigation on the control panel .....	73
7.4	Using the Monitoring menu (M1) .....	75
7.5	Using the Parameter menu (M2) .....	76
7.5.1	Finding the parameter .....	76
7.5.2	Editing the text values .....	77
7.5.3	Editing the numerical values .....	78
7.6	Using the Keypad control menu (M3) .....	79
7.6.1	Control place .....	79
7.6.2	The keypad reference submenu (P3.2) .....	80
7.6.3	Changing the rotation direction .....	81
7.6.4	Disabling the Stop motor function .....	81
7.6.5	Special functions in the Keypad control menu .....	81
7.7	Using the Active faults menu (M4) .....	82
7.7.1	The fault time data record .....	82
7.8	Using the Fault history menu (M5) .....	84
7.8.1	Resetting the Fault history menu .....	85

7.9	Using the System menu (M6)	85
7.9.1	Changing the language	89
7.9.2	Changing the application	89
7.9.3	Copy parameters (S6.3)	90
7.9.4	Comparing the parameters	93
7.9.5	Security	95
7.9.6	Keypad settings	99
7.9.7	Hardware settings	101
7.9.8	System info	106
7.10	Using the Expander board menu (M7)	111
7.10.1	Examining the connected expander boards	112
7.10.2	Finding the expander board parameters	113
7.11	Further keypad functions	114
<b>8</b>	<b>Commissioning and additional instructions</b>	<b>115</b>
8.1	Commissioning safety	115
8.2	Commissioning of the drive	116
8.3	Operation of the motor	116
8.3.1	Checks before starting the motor	116
8.3.2	The Run test without the motor	117
8.3.3	Start-up test	117
8.3.4	Identification run	117
8.3.5	Connecting the motor to the process	117
8.4	Measuring the cable and motor insulation	118
8.5	Installation in an IT system	118
8.5.1	Enclosure sizes FR4, FR5, and FR6	118
8.5.2	Enclosure size FR7	119
8.5.3	Enclosure sizes FR8 - FR11	121
8.6	Installation in a corner grounded network	121
8.7	Maintenance	121
8.7.1	Capacitor reforming	122
<b>9</b>	<b>Technical data for VACON® NXS and NXP</b>	<b>123</b>
9.1	AC drive power ratings	123
9.1.1	Mains voltage 208-240 V	123
9.1.2	Mains voltage 380-500 V	125
9.1.3	Mains voltage 525-690 V (UL rating 600 V)	127
9.1.4	Overload capability	129
9.1.5	Brake resistor ratings	130
9.2	VACON® NXS and NXP - technical data	135
9.3	The compliance with the product standard IEC/EN 61800-3 + A1	140
9.3.1	Environment definitions in product standard IEC/EN 61800-3 + A1	142
<b>10</b>	<b>Fault tracing</b>	<b>143</b>
10.1	Resetting a fault	143
10.2	Fault codes	145
<b>11</b>	<b>Appendix 1</b>	<b>153</b>
11.1	Power losses for 380-500 V	153
11.2	Power losses of 525-690 V	158

# 1 APPROVALS

Here are the approvals that have been granted to this VACON® AC drive.

1. EC Declaration of conformity
  - Find the EC Declaration of Conformity on the next pages.
2. UL approval
  - cULus approval file number E171278.
3. RCM approval
  - RCM approval number E2204.

See the nameplate of the drive for more approvals.



**Danfoss A/S**

DK-6430 Nordborg  
Denmark  
CVR nr.: 20 16 57 15

Telephone: +45 7488 2222  
Fax: +45 7449 0949

**EU DECLARATION OF CONFORMITY****Danfoss A/S**

Vacon Ltd

declares under our sole responsibility that the

Product(s) VACON® NXS/P AC drive

Type(s) VACON® NXS/P 0003 2...0300 2  
VACON® NXS/P 0003 5...1030 5  
VACON® NXS/P 0004 6...0820 6



Covered by this declaration is in conformity with the following directive(s), standard(s) or other normative document(s), provided that the product is used in accordance with our instructions.

Safety: EN 61800-5-1: 2007  
EN 60204-1: 2009+A1:2009 (as relevant)

EMC: EN 61800-3: 2004 + A1: 2012

and conforms to the relevant safety provisions of Low Voltage Directive 2006/95/EC (until April 19th, 2016), 2014/35/EU (from April 20th, 2016) and EMC Directive 2004/108/EC (until April 19th, 2016), 2014/30/EU (from April 20th, 2016).

The year the CE marking was affixed: 2002

Date	Issued by	Date	Approved by
15-04-2016	Signature Name Title	15-04-2016	Signature Name Title
	 <b>Antti Vuola</b> Head of Standard Drives		 <b>Timo Kasi</b> VP, Design Center Finland and Italy

Danfoss only vouches for the correctness of the English version of this declaration. In the event of the declaration being translated into any other language, the translator concerned shall be liable for the correctness of the translation.



## 2 SAFETY

### 2.1 THE SAFETY SYMBOLS USED IN THE MANUAL

This manual contains warnings and cautions, which are identified with safety symbols. The warnings and cautions give important information on how to prevent injury and damage to the equipment or your system.

Read the warnings and cautions carefully and obey their instructions.

**Table 1: The safety symbols**

The safety symbol	The safety word	Description
	WARNING!	If you do not obey the instructions, injury or death is possible.
	CAUTION!	If you do not obey the instructions, damage to the equipment is possible.
	HOT SURFACE!	If you do not obey the instructions, burns are possible.

### 2.2 WARNING



#### WARNING!

Do not touch the components of the power unit when the drive is connected to mains. The components are live when the drive is connected to mains. A contact with this voltage is very dangerous.



#### WARNING!

Do not touch the motor cable terminals U, V, W, the brake resistor terminals or the DC terminals when the drive is connected to mains. These terminals are live when the drive is connected to mains, also when the motor does not operate.



#### WARNING!

Do not touch the control terminals. They can have a dangerous voltage also when the drive is disconnected from mains.

**WARNING!**

Before you do electrical work on the drive, disconnect the drive from the mains and make sure that the motor has stopped. Lock out and tag out the power source to the drive. Make sure that no external source generates unintended voltage during work. Note that also the load side of the drive can generate voltage.

Wait 5 minutes before you open the cabinet door or the cover of the AC drive. Use a measuring device to make sure that there is no voltage. The terminal connections and the components of the drive can be live 5 minutes after it is disconnected from the mains and the motor has stopped.

**WARNING!**

Before you connect the drive to mains, make sure that the front cover and the cable cover of the drive are closed. The connections of the AC drive are live when the drive is connected to mains.

**WARNING!**

Disconnect the motor from the drive if an accidental start can be dangerous. When there is a power-up, a power break or a fault reset, the motor starts immediately if the start signal is active, unless the pulse control for Start/Stop logic is selected. If the parameters, the applications or the software change, the I/O functions (including the start inputs) can change.

**WARNING!**

Wear protective gloves when you do mounting, cabling or maintenance operations. There can be sharp edges in the AC drive that can cause cuts.

**2.3 CAUTION****CAUTION!**

Do not move the AC drive. Use a fixed installation to prevent damage to the drive.

**CAUTION!**

Do not make measurements when the AC drive is connected to mains. It can cause damage to the drive.

**CAUTION!**

Make sure that there is reinforced protective ground connection. It is mandatory, because the touch current of the AC drives is more than 3.5 mA AC (refer to EN 61800-5-1). See chapter 2.4 *Grounding and earth fault protection*.

**CAUTION!**

Do not use spare parts that are not from the manufacturer. Using other spare parts can cause damage to the drive.

**CAUTION!**

Do not touch the components on the circuit boards. Static voltage can cause damage to these components.

**CAUTION!**

Make sure that the EMC level of the AC drive is correct for your mains. See chapter 8.5 *Installation in an IT system*. An incorrect EMC level can cause damage to the drive.

If you use Corner-grounding, change the EMC level to C4, see chapter 8.5 *Installation in an IT system*.

For information on permitted drive types for Corner-grounding, see chapter 8.6 *Installation in a corner grounded network*.

**CAUTION!**

Prevent radio interference. The AC drive can cause radio interference in a domestic environment.

**NOTE!**

If you activate the autoreset function, the motor starts automatically after an automatic fault reset. See the Application Manual.

**NOTE!**

If you use the AC drive as a part of a machine, the machine manufacturer must supply a mains disconnection device (refer to EN 60204-1).

## 2.4 GROUNDING AND EARTH FAULT PROTECTION

**CAUTION!**

The AC drive must always be grounded with a grounding conductor that is connected to the grounding terminal that is identified with the symbol  $\oplus$ . Not using a grounding conductor can cause damage to the drive.

The touch current of the drive is more than 3.5 mA AC. The standard EN 61800-5-1 tells that 1 or more of these conditions for the protective circuit must be true.

**The connection must be fixed.**

- a) The protective grounding conductor must have a cross-sectional area of minimum 10 mm<sup>2</sup> Cu or 16 mm<sup>2</sup> Al. OR
- b) There must be an automatic disconnection of the mains, if the protective grounding conductor breaks. See chapter 5 *Power cabling*. OR
- c) There must be a terminal for a second protective grounding conductor in the same cross-sectional area as the first protective grounding conductor.

**Table 2: Protective grounding conductor cross-section**

Cross-sectional area of the phase conductors (S) [mm <sup>2</sup> ]	The minimum cross-sectional area of the protective grounding conductor in question [mm <sup>2</sup> ]
$S \leq 16$	S
$16 < S \leq 35$	16
$35 < S$	S/2

The values of the table are valid only if the protective grounding conductor is made of the same metal as the phase conductors. If this is not so, the cross-sectional area of the protective grounding conductor must be determined in a manner that produces a conductance equivalent to that which results from the application of this table.

The cross-sectional area of each protective grounding conductor that is not a part of the mains cable or the cable enclosure, must be a minimum of:

- 2.5 mm<sup>2</sup> if there is mechanical protection, and
- 4 mm<sup>2</sup> if there is not mechanical protection. If you have cord-connected equipment, make sure that the protective grounding conductor in the cord is the last conductor to be interrupted, if the strain-relief mechanism breaks.

Obey the local regulations on the minimum size of the protective grounding conductor.

**NOTE!**

Because there are high capacitive currents in the AC drive, it is possible that the fault current protective switches do not operate correctly.

**CAUTION!**

Do not do voltage withstand tests on the AC drive. The manufacturer has already done the tests. Doing voltage withstand tests can cause damage to the drive.

## 2.5 USING AN RCD OR AN RCM DEVICE

The drive can cause a current in the protective grounding conductor. You can use a residual current-operated protective (RCD) device, or a residual current-operated monitoring (RCM) device to give protection against a direct or an indirect contact. Use a type B RCD or RCM device on the mains side of the drive.

**NOTE!** You can download the English and French product manuals with applicable safety, warning and caution information from <http://drives.danfoss.com/knowledge-center/technical-documentation/>.

**REMARQUE** Vous pouvez télécharger les versions anglaise et française des manuels produit contenant l'ensemble des informations de sécurité, avertissements et mises en garde applicables sur le site <http://drives.danfoss.com/knowledge-center/technical-documentation/>.

### 3 RECEIVING THE DELIVERY

Before a VACON® AC drive is sent to the customer, the manufacturer makes many tests on the drive. However, after you remove the packaging, examine the drive for transport damages.

If the drive was damaged during the shipping, speak to the cargo insurance company or the carrier.

To make sure that the contents of the delivery is correct and complete, compare the type designation of the product to the type designation code. See Chapter 3.2 *Type designation code*.

#### 3.1 PACKAGE LABEL

To make sure that the delivery is correct, compare your order data to the data on the package label. If the delivery does not agree with your order, speak to the vendor immediately.

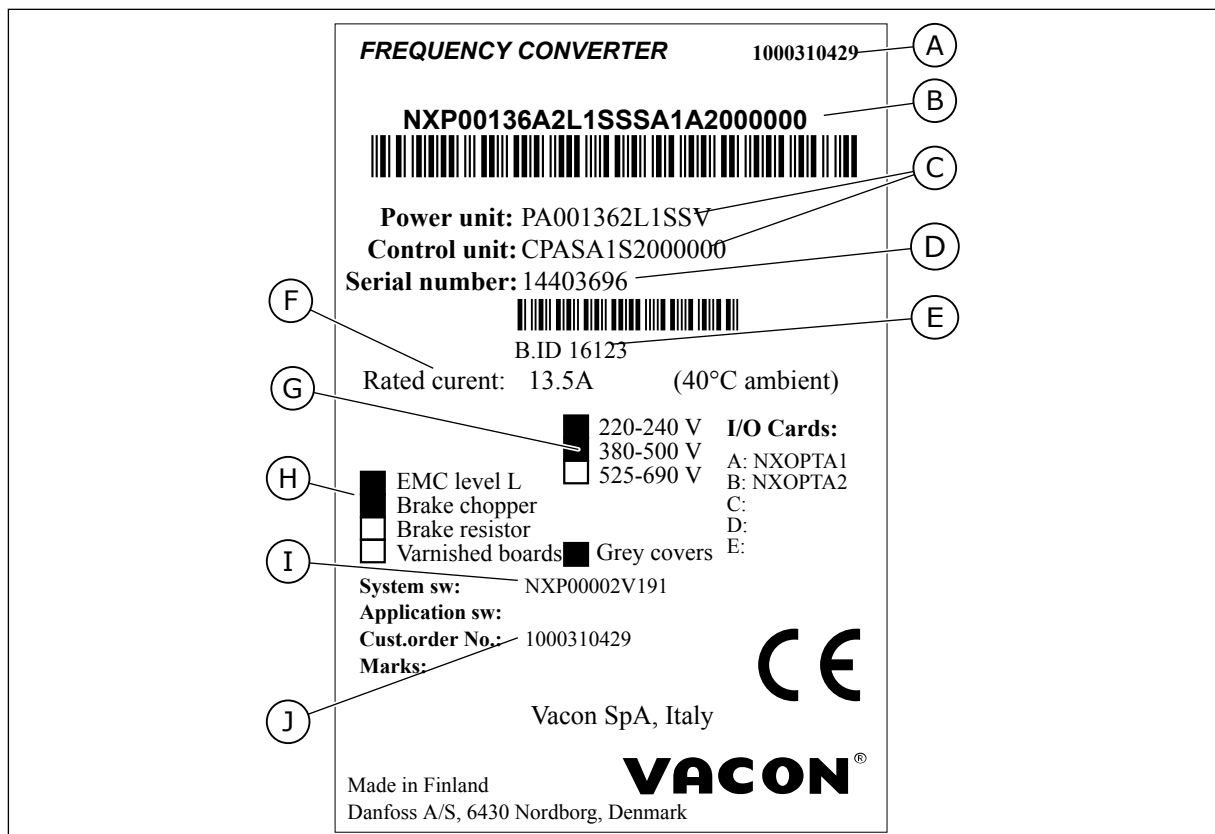

Fig. 2: The package label of VACON® AC drives

- |   |                                     |
|---|-------------------------------------|
| A. The order number of VACON®                             | F. The nominal output current       |
| B. The type designation code                              | G. The mains voltage                |
| C. The type codes for the power unit and the control unit | H. The most general options         |
| D. The serial number                                      | I. The firmware code                |
| E. The batch ID   | J. The order number of the customer |

### 3.2 TYPE DESIGNATION CODE

The type designation code of VACON® is made of standard codes and optional codes. Each part of the type designation code agrees to the data in your order. The code can have this format, for example:

NXS 0000 5 A 2 H 1 SSV A1A20000C3

NXP 0000 5 A 2 H 1 SSV A1A20000C3

**Table 3: The description of the parts in the type designation code**

Code	Description
NXS	The product range:  NXS = standard NXP = high-performance
0000	The nominal current (low overload):  0007 = 7 A 0022 = 22 A 0205 = 205 A, and so on
5	The nominal mains voltage (all 3-phase):  2 = 208-240 Vac 5 = 380-500 Vac 6 = 525-690 Vac
A	The control panel:  A = standard (text keypad) B = no local control keypad F = dummy keypad G = graphic display
2	The enclosure class:  0 = IP00 2 = IP21 (UL Type 1) 5 = IP54 (UL Type 12) T = flange mounted (through-hole mounted)
H	The EMC emission level:  C = complies with the category C1 of standard IEC/EN 61800-3 + A1, 1st environment and nominal voltage less than 1000 V H = complies with the category C2 of standard IEC/EN 61800-3 + A1, fixed installations and nominal voltage less than 1000 V L = complies with the category C3 of standard IEC/EN 61800-3 + A1, 2nd environment and nominal voltage less than 1000 V T = complies with the standard IEC/EN 61800-3 + A1 when used in IT networks N = No EMC emission protection. An external EMC filter is necessary.



**Table 3: The description of the parts in the type designation code**

Code	Description
1	<p>The brake chopper:            0 = No brake chopper            1 = Internal brake chopper            2 = Internal brake chopper and resistor</p> <p><b>NOTE!</b></p> <p>A brake resistor is available:</p> <ul style="list-style-type: none"> <li>• as an internal option for               <ul style="list-style-type: none"> <li>• 208-240 V (FR4-FR6)</li> <li>• 380-500 V (FR4-FR6)</li> </ul> </li> <li>• as an option for external installation for               <ul style="list-style-type: none"> <li>• 208-240 V (FR7-FR11)</li> <li>• 380-500 V (FR7-FR11)</li> <li>• 525-690 V (all enclosure sizes)</li> </ul> </li> </ul>
SSV	<p>The hardware changes:</p> <ul style="list-style-type: none"> <li>• The supply, the first letter (<b>Xxx</b>):           <ul style="list-style-type: none"> <li>• S = 6-pulse connection (FR4 to FR11)</li> <li>• B = Additional DC-connection (FR8 to FR11)</li> <li>• J = FR10 to 11 stand-alone with main switch and DC-link terminals</li> </ul> </li> <li>• The mounting, the second letter: (<b>xXx</b>):           <ul style="list-style-type: none"> <li>• S = Air-cooled drive</li> </ul> </li> <li>• The boards, the third letter (<b>xxX</b>):           <ul style="list-style-type: none"> <li>• S = Standard boards (FR4 to FR8)</li> <li>• V = Coated boards (FR4 to FR8)</li> <li>• F = Standard boards (FR9 to FR11)</li> <li>• G = Coated boards (FR9 to FR11)</li> <li>• A = Standard boards (FR10 to FR11 standalone drives)</li> <li>• B = Coated boards (FR10 to FR11 standalone drives)</li> <li>• N = separate IP54 (UL Type 12) control box, standard boards (FR9 IP00, ≥ FR10)</li> <li>• O = separate IP54 (UL Type 12) control box, coated boards (FR9 IP00, ≥ FR10)</li> <li>• X = separate IP00 control box, standard boards (FR9 IP00)</li> <li>• Y = separate IP00 control box, coated boards (FR9 IP00)</li> </ul> </li> </ul>
A1A20000C3	<p>The option boards. 2 characters for each slot.            00 = the slot is not used</p> <p><b>The option board abbreviations:</b></p> <p>A = basic I/O board            B = expander I/O board            C = fieldbus board            D = special board            E = fieldbus board</p> <p>For example, C3 = Profibus DP</p>

**NOTE!**

For other possible installation combinations, speak to the distributor near you.

### 3.3 STORAGE

If you must keep the AC drive in storage before you use it, make sure that the ambient conditions agree to these:

Storage temperature: -40...+70°C (-40...+158°F)

Relative humidity: 0 to 95%, no condensation

If you must keep the AC drive in storage for a long time, you must connect the power to the AC drive each year. Keep the power on for a minimum of 2 hours.

We do not recommend a long storage time. If the storage time is more than 12 months, you must charge the electrolytic DC capacitors with caution. To reform the capacitors, obey the instructions in Chapter 8.7.1 *Capacitor reforming*.

### 3.4 REMOVING THE PACKAGING AND LIFTING THE AC DRIVE

To lift the AC drives larger than FR7 out of the package, use a jib crane. Speak to the factory or the distributor near you to get information on how to lift the AC drive safely.

After you lift the drive, do a check for signs of damage on the drive.

#### 3.4.1 WEIGHT OF THE AC DRIVE

The weights of AC drives of different enclosure sizes are very different. It can be necessary for you to use a lifting device to move the drive from its package.

**Table 4: The weights of the different enclosure sizes**

Enclosure size	Weight, IP21/IP54 [kg]	Weight, UL Type 1 / Type 12 [lb.]
FR4	5.0	11.0
FR5	8.1	17.9
FR6	18.5	40.8
FR7	35.0	77.2
FR8	58.0	128
FR9	146	322
FR10	340	750
FR11 *	470	1036

\*) FR11, the product types 0460 and 0502: 400 kg (882 lb.)

### 3.5 ACCESSORIES

After you open the package and lift the drive out, make sure that you received all the accessories. The content of the accessories bag is different for the different enclosure sizes and enclosure classes.

#### 3.5.1 FR4-FR6 CABLE ACCESSORIES

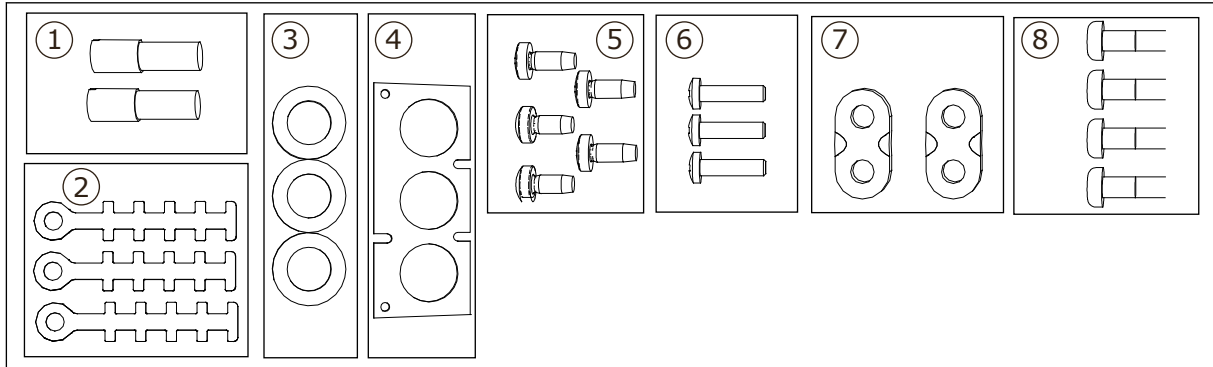

Fig. 3: The contents of accessories bag

#### Components:

1. The grounding terminals (FR4, FR5), 2 pieces
2. The grounding clamps for control cable, 3 pieces
3. The rubber grommets (sizes vary from class to class), 3 pieces
4. The cable entry flange
5. Screws, M4x10, 5 pieces
6. Screws, M4x16, 3 pieces
7. The grounding clamps for grounding conductor (FR6), 2 pieces
8. The grounding screws M5x16 (FR6), 4 pieces

#### INSTALLING THE ACCESSORIES

- 1 Make sure that you received all the accessories.

- 2 Open the cover of the AC drive.

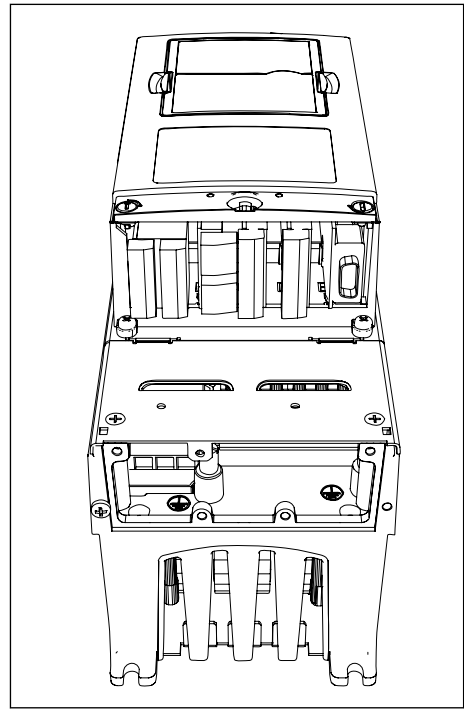

- 3 Remove the cable cover. See the locations of:

1. the grounding terminals (FR4/FR5)
2. the grounding clamps for grounding conductor (FR6)

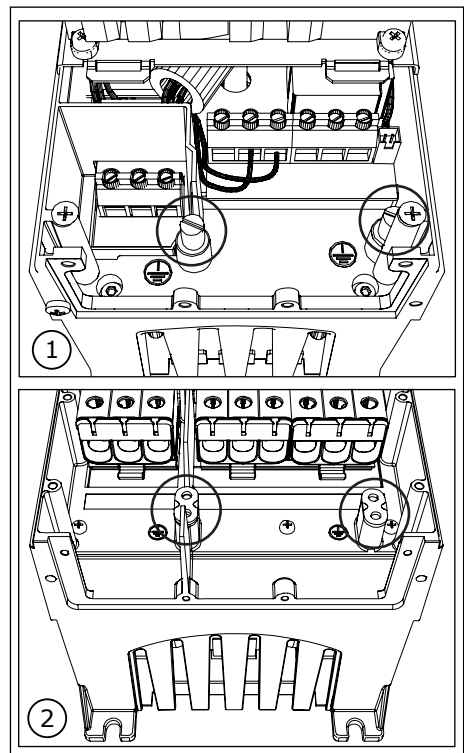

- 4 Attach again the cable cover. Attach the grounding clamps for control cable with 3 pieces of M4x16 screws.

**NOTE!**

The location of the grounding bar in FR6 is different from the picture.

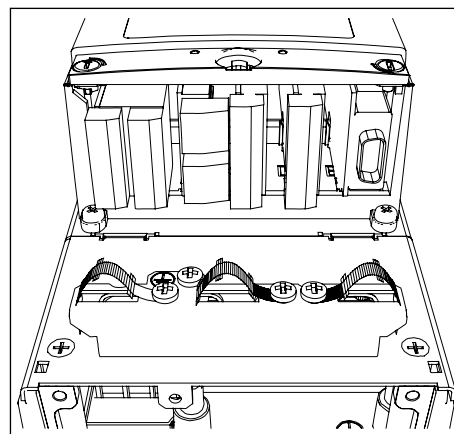

- 5 Put the rubber grommets in the openings.

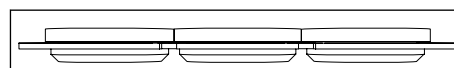

- 6 Attach the cable entry flange to the frame of the AC drive with 5 pieces of M4x10 screws. Close the cover of the AC drive. For the tightening torques of the screws, see *Table 5*.

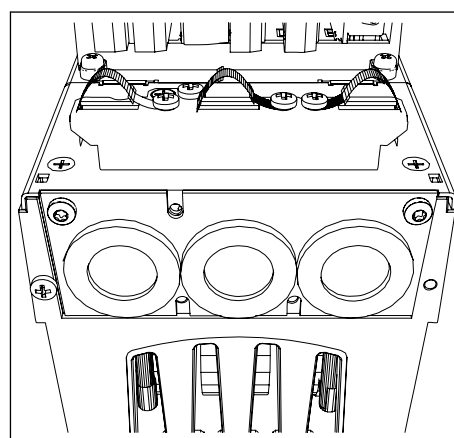

**Table 5: The tightening torques of the cover screws**

Enclosure size	Cable cover	Cover of the AC drive
FR4 IP54	2.2 Nm	0.7 Nm
FR5 IP21/ IP54	2.2 Nm	0.7 Nm
FR6 IP21/ IP54	2.2 Nm	0.7 Nm
FR7 IP21/ IP54	2.4 Nm	0.8 Nm
FR8 IP54	0.8 Nm *)	0.8 Nm
FR9	0.8 Nm	0.8 Nm

\*) The cover of the power unit

### 3.5.2 FR7-FR8 CABLE ACCESSORIES

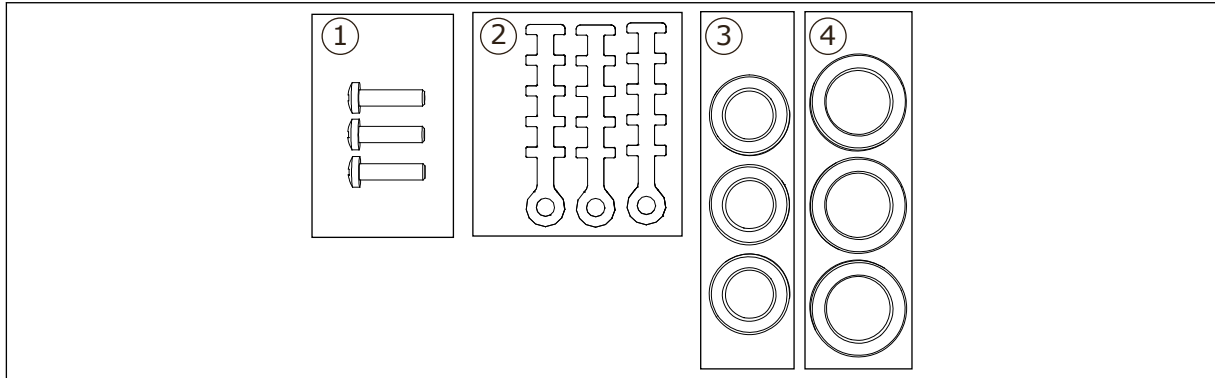

Fig. 4: The contents of accessories bag

#### Components:

1. Screws, M4x16, 3 pieces
2. The grounding clamps for control cable, 3 pieces
3. The rubber grommets GD21 (FR7 IP54/UL Type 12), 3 pieces / (FR8), 6 pieces
4. The rubber grommets GDM36 (FR7), 3 pieces

#### INSTALLING THE ACCESSORIES

1. Make sure that you received all necessary components.
2. Open the cover of the AC drive.

- 3 Attach the grounding clamps for control cable on the grounding level with M4x16 screws:

1. FR7 standard
2. FR7 PROFIBUS
3. FR8 standard
4. FR8 PROFIBUS

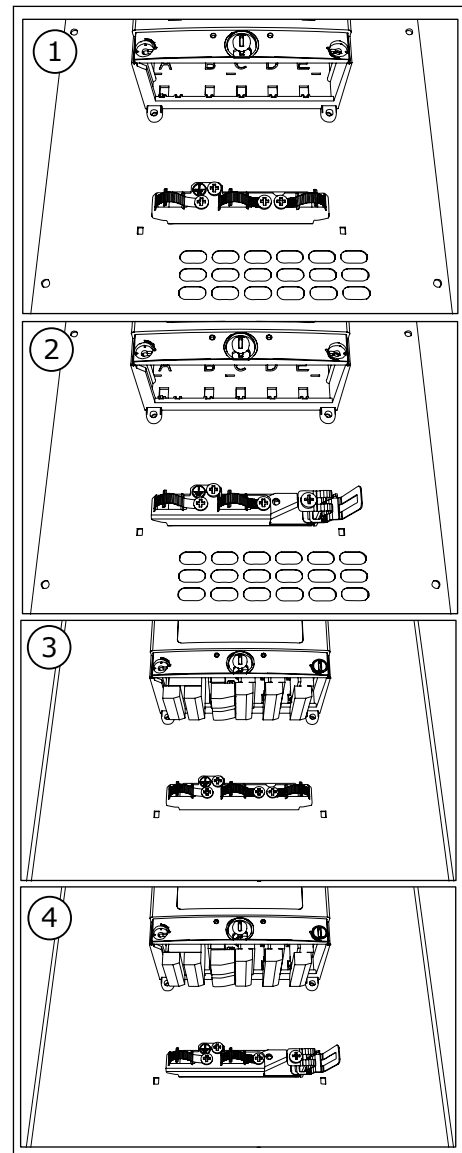

4 Put the rubber grommets in the openings:

1. FR7 IP21 (UL Type 1)
2. FR7 IP54 (UL Type 12)
3. FR8

See also step 5 in *3.5.1 FR4-FR6 cable accessories* for how to put the grommets correctly.

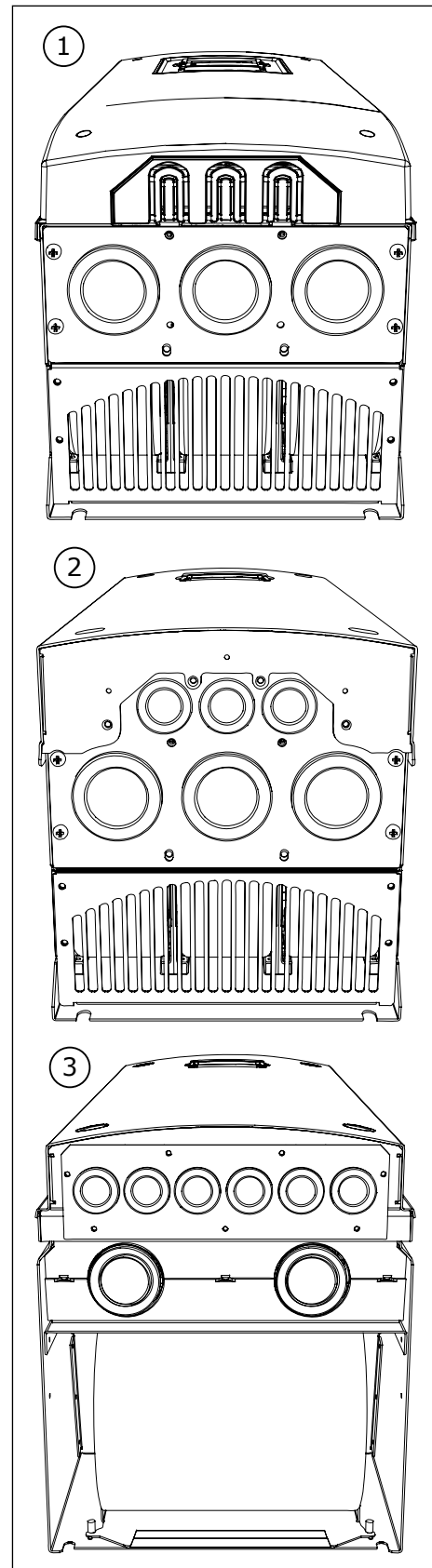



- 5 Close the cover of the AC drive. For the tightening torques of the screws, see *Table 5 The tightening torques of the cover screws*.

### 3.6 "PRODUCT MODIFIED" LABEL

In the accessories bag, there is also a "product modified" label. The function of the label is to tell the service personnel about the changes that are made in the AC drive. Attach the label on the side of the AC drive to know where to find it. If you make changes in the AC drive, write the change on the label.

<b>Drive modified:</b>	
<input type="checkbox"/> Option board: NXOPT.....	Date:.....
in slot: A B C D E	Date:.....
<input type="checkbox"/> IP54 upgrade/Collar	Date:.....
<input type="checkbox"/> EMC level modified: H/L to T	Date:.....

### 3.7 DISPOSAL

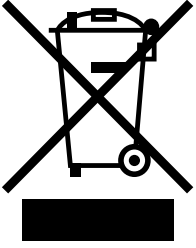
	<p>When the drive is at the end of its operation life, do not discard it as a part of municipal waste. You can recycle the primary components of the drive. You must disassemble some components before you can remove the different materials. Recycle the electrical and electronic components as waste.</p> <p>To make sure that the waste is recycled correctly, send the waste to a recycling centre. You can also send the waste back to the manufacturer.</p> <p>Obey the local and other applicable regulations.</p>
--	--

## 4 MOUNTING

### 4.1 GENERAL INFORMATION ABOUT MOUNTING

Install the AC drive in vertical or horizontal position on the wall. If you install the drive in a horizontal position, there is no protection against drops of water that fall vertically.

You can also install the AC drive into the cabinet wall with a flange mounting option (through-hole mounting). With the flange mounting, the enclosure class of the power unit is IP54 (UL Type 12) and the enclosure class of the control unit is IP21 (UL Type 1).

Attach the AC drive with the screws and other components that you received in the delivery. Make sure that there is sufficiently free space around the AC drive for cooling, see 4.5 *Cooling*. Also make sure that the mounting surface is sufficiently flat.

For the dimensions of the wall-mounted and flange-mounted VACON® NX AC drives, see the chapters below.

The sizes FR10 to FR11 are standalone AC drives. The enclosures have fixing holes. For dimensions, see Chapter 4.4.1 *Standalone (FR10 and FR11)*.

## 4.2 DIMENSIONS FOR WALL MOUNTING

### 4.2.1 WALL MOUNTING OF FR4-FR6

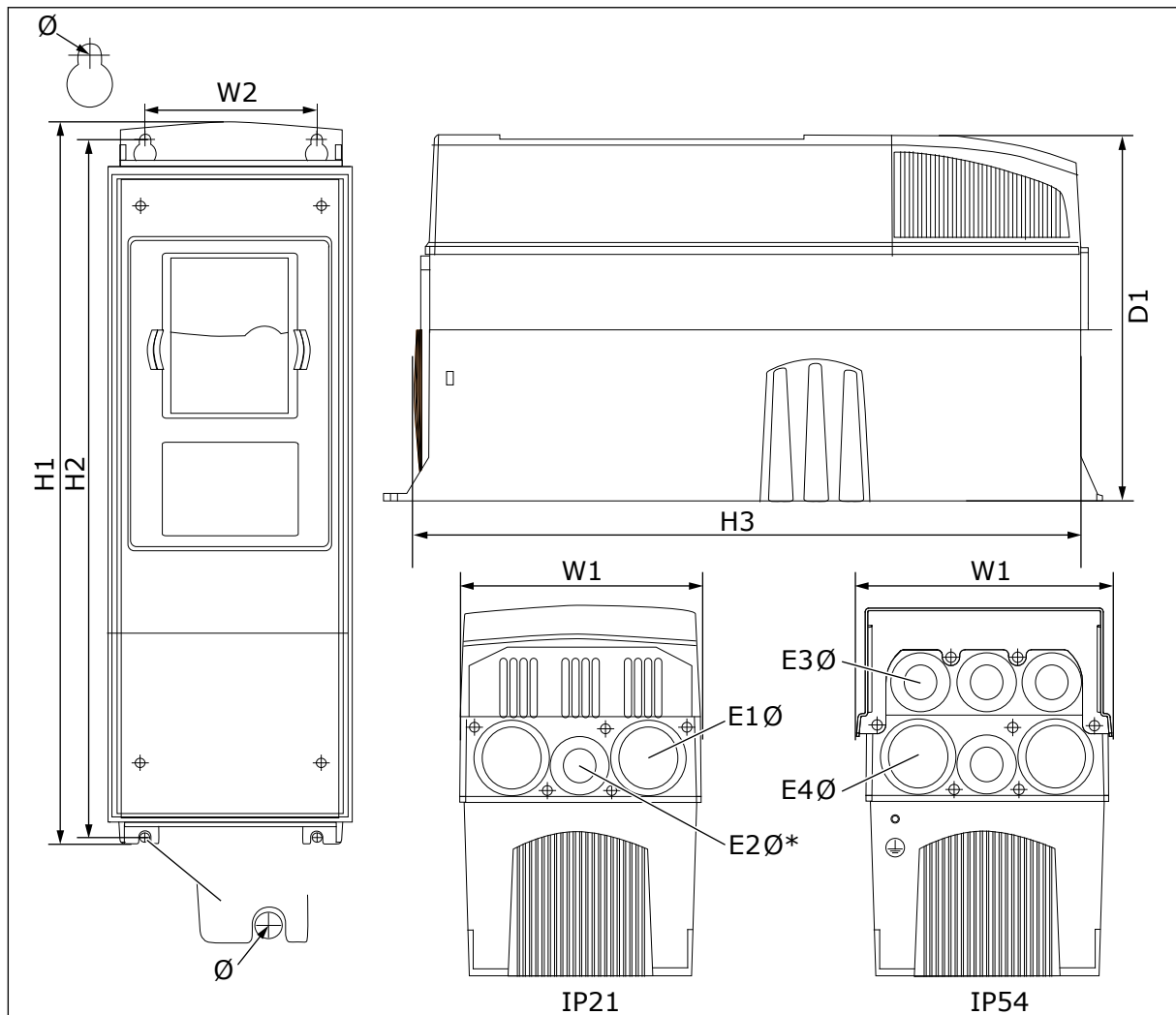

Fig. 5: Dimensions of the NXS and NXP AC drive, FR4-FR6

**Table 6: Dimensions in mm (in inch) of the NXS and NXP AC drive, FR4-FR6**

Drive type	W1	W2	H1	H2	H3	D1	Ø	E1Ø	E2Ø*	E3Ø	E4Ø**
0004 2-0012 2 0003 5-0012 5	128 (5.04)	100 (3.94)	327 (12.87)	313 (12.32)	292 (11.5)	190 (7.48)	7 (0.27)	3 x 28.3 (3 x 1.11)	- (-)	6 x 28.3 (6 x 1.11)	- (-)
0017 2-0031 2 0016 5-0031 5	144 (5.67)	100 (3.94)	419 (16.5)	406 (15.98)	391 (15.39)	214 (8.43)	7 (0.27)	2 x 37 (2 x 1.46)	28.3 (1.11)	2 x 37 (2 x 1.46)	4 x 28.3 (4 x 1.11)
0048 2-0061 2 0038 5-0061 5 0004 6-0034 6	195 (7.68)	148 (5.83)	558 (21.97)	541 (21.3)	519 (20.43)	237 (9.33)	9 (0.35)	3 x 37 (3 x 1.46)	- (-)	3 x 37 (3 x 1.46)	3 x 28.3 (3 x 1.11)

\* = FR5 only

\*\* = FR5 and FR6 only

**4.2.2 WALL MOUNTING OF FR7**

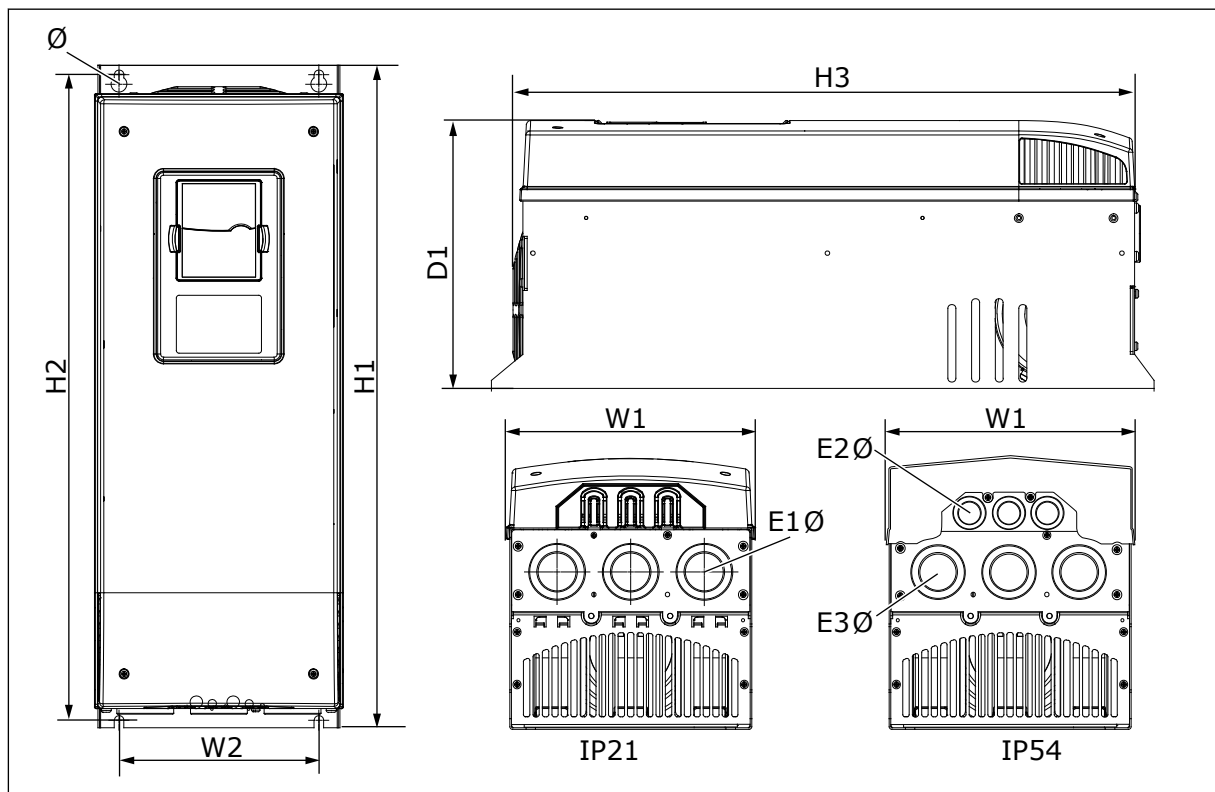

**Fig. 6: Dimensions of the NXS and NXP AC drive, FR7**

**Table 7: Dimensions in mm (in inch) of the NXS and NXP AC drive, FR7**

Drive type	W1	W2	H1	H2	H3	D1	Ø	E1Ø	E2Ø	E3Ø
0075 2-0114 2								3 x	3 x	3 x
0072 5-0105 5	237	190	630	614	591	257	9	50.3	50.3	28.3
0041 6-0052 6	(9.33)	(7.48)	(24.80)	(24.17)	(23.27)	(10.12)	(0.35)	(3 x 1.98)	(3 x 1.98)	(3 x 1.11)

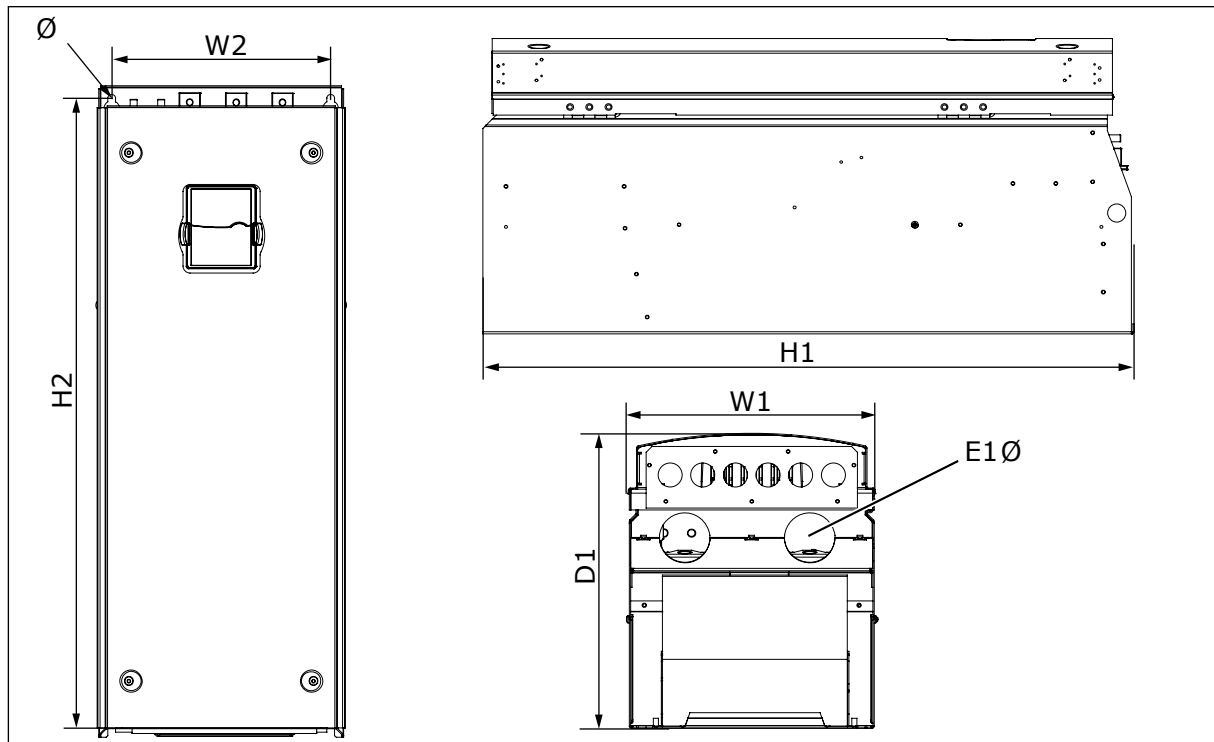
**4.2.3 WALL MOUNTING OF FR8****Fig. 7: Dimensions of the NXS and NXP AC drive, FR8****Table 8: Dimensions in mm (in inch) of the NXS and NXP AC drive, FR8**

Drive type	W1	W2	H1	H2	D1	Ø	E1Ø
0140 2-0205 2							
0140 5-0205 5	291	255	758	732	344	9	2 x 59
0062 6-0100 6	(11.47)	(10.04)	(29.88)	(28.81)	(13.54)	(0.35)	(2 x 2.32)

4.2.4 WALL MOUNTING OF FR9

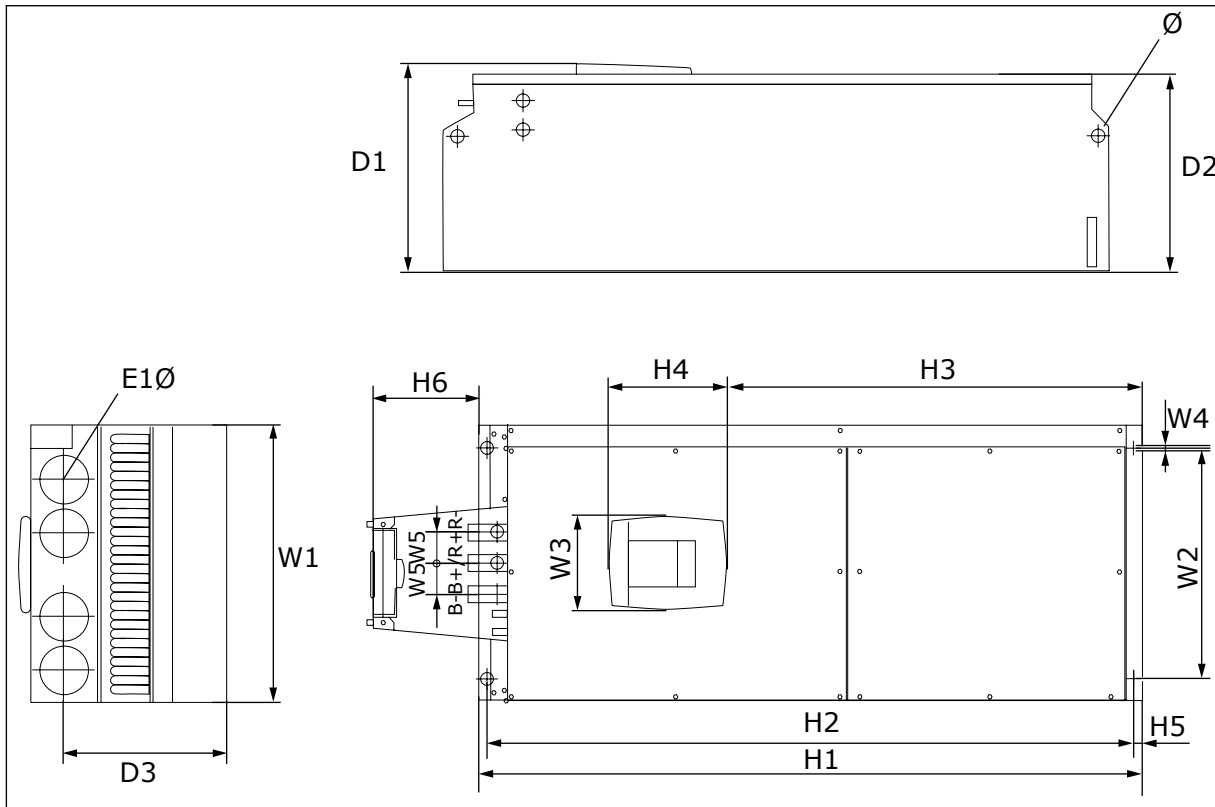

Fig. 8: Dimensions of the NXS and NXP AC drive, FR9

Table 9: Dimensions in mm (in inch) of the NXS and NXP AC drive, FR9, part 1

Drive type	W1	W2	W3	W4	W5	D1	D2	D3
0261 2-0300 2	480	400	165	9	54	362	340	285
0261 5-0300 5	(18.9)	(15.75)	(15.74)	(0.35)	(2.13)	(14.25)	(13.39)	(11.22)
0125 6-0208 6								

Table 10: Dimensions in mm (in inch) of the NXS and NXP AC drive, FR9, part 2

Drive type	H1	H2	H3	H4	H5	H6	Ø	E1Ø
0261 2-0300 2	1150*	1120	721	205	16	188	21	59
0261 5-0300 5	(45.28*)	(44.09)	(28.39)	(8.07)	(0.63)	(7.40)	(0.83)	(2.32)
0125 6-0208 6								

\* = Brake resistor terminal box (H6) not included. For FR8 and FR9 when Brake chopper or Additional DC connection is selected in type designation code, the total height of the AC drive is increased by 203 mm (7.99 inch).

## 4.3 DIMENSIONS FOR FLANGE MOUNTING

### 4.3.1 FLANGE MOUNTING OF FR4 TO FR6

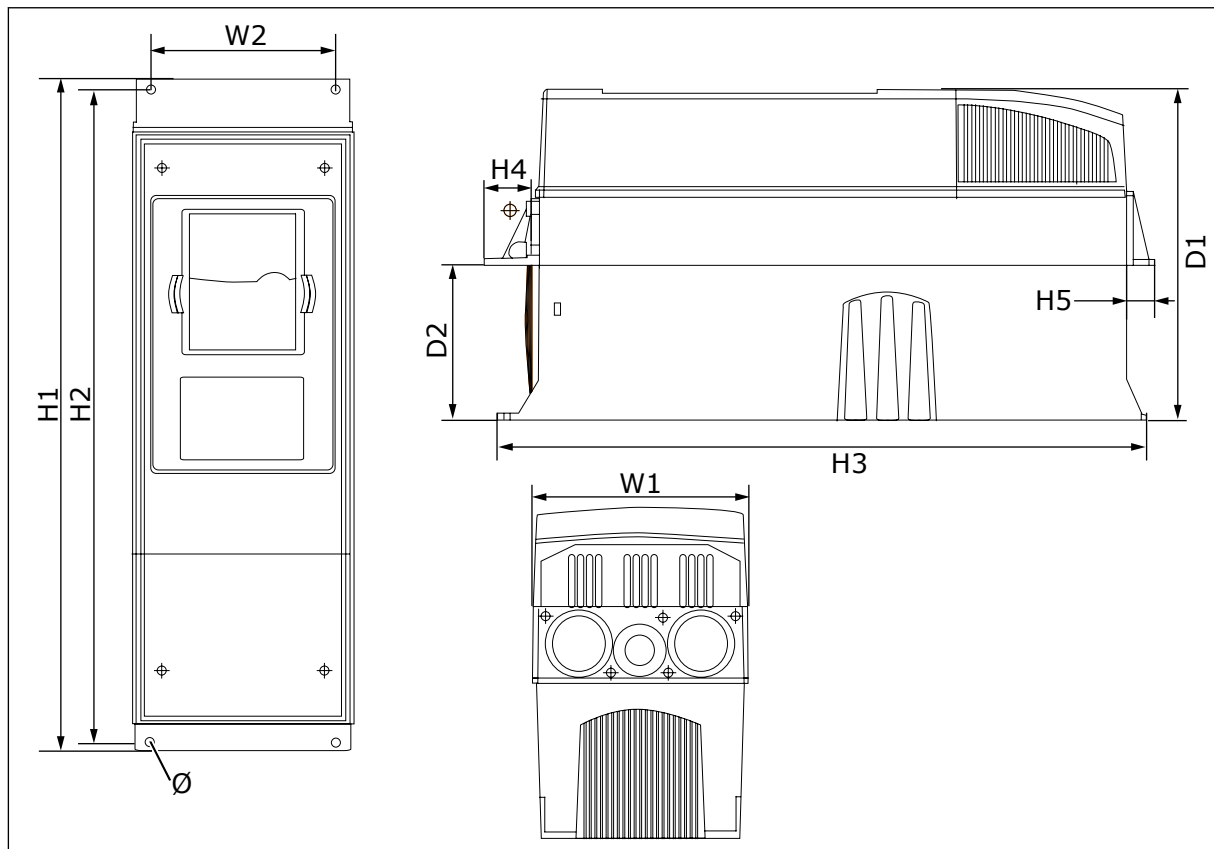

Fig. 9: Dimensions of the NXS and NXP AC drive with flange, FR4-FR6

Table 11: Dimensions in mm (in inch) of the NXS and NXP AC drive with flange, FR4-FR6

Drive type	W1	W2	H1	H2	H3	H4	H5	D1	D2	Ø
0004 2-0012 2 0003 5-0012 5	128 (5.03)	113 (4.45)	337 (13.27)	325 (12.8)	327 (12.9)	30 (1.18)	22 (0.87)	190 (7.48)	77 (3.03)	7 (0.27)
0017 2-0031 2 0016 5-0031 5	144 (5.67)	120 (4.72)	434 (17.09)	420 (16.54)	419 (16.5)	36 (1.42)	18 (0.71)	214 (8.43)	100 (3.94)	7 (0.27)
0048 2-0061 2 0038 5-0061 5 0004 6-0034 6	195 (7.68)	170 (6.69)	560 (22.05)	549 (21.61)	558 (22)	30 (1.18)	20 (0.79)	237 (9.33)	106 (4.17)	6.5 (0.26)

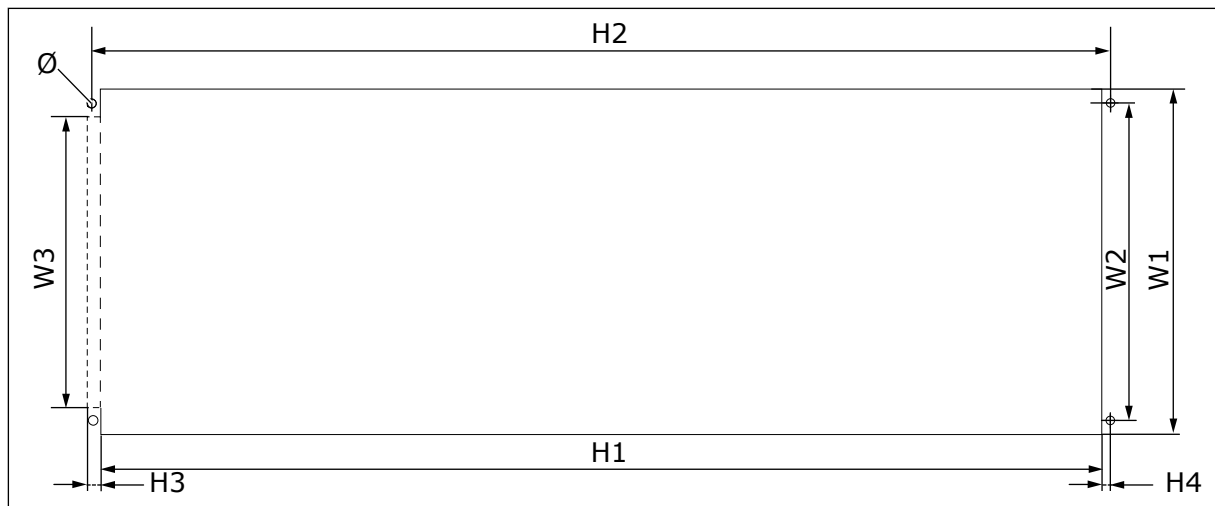

Fig. 10: The dimensions of the opening and drive outline with flange, FR4 to FR6

**Table 12: The dimensions in mm (in inch) of the opening and drive outline with flange, FR4 to FR6**

Drive type	W1	W2	W3	H1	H2	H3	H4	Ø
0004 2-0012 2 0003 5-0012 5	123 (4.84)	113 (4.45)	- (-)	315 (12.40)	325 (12.8)	- (-)	5 (0.20)	6.5 (0.26)
0017 2-0031 2 0016 5-0031 5	135 (5.31)	120 (4.72)	- (-)	410 (16.14)	420 (16.54)	- (-)	5 (0.20)	6.5 (0.26)
0048 2-0061 2 0038 5-0061 5 0004 6-0034 6	185 (7.28)	170 (6.69)	157 (6.18)	539 (21.22)	549 (21.61)	7 (0.27)	5 (0.20)	6.5 (0.26)



## 4.3.2 FLANGE MOUNTING OF FR7 AND FR8

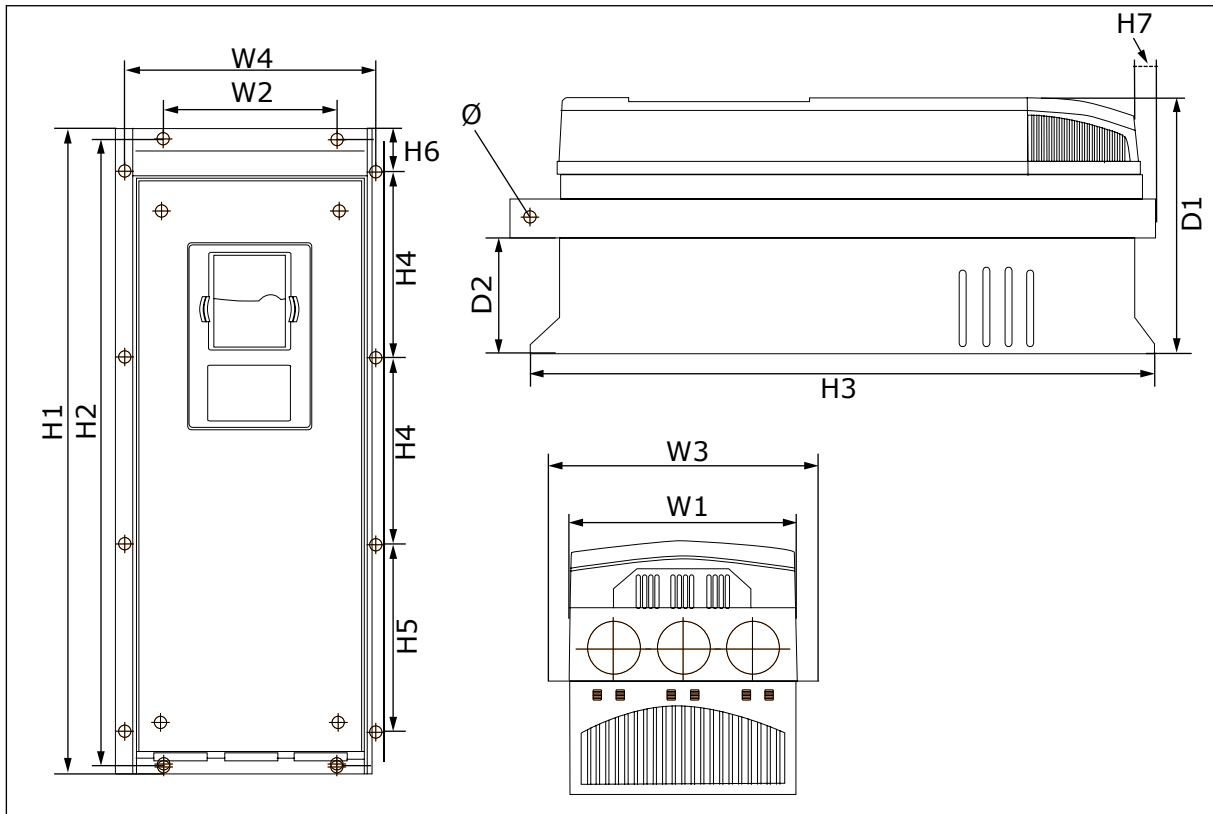

Fig. 11: Dimensions of the NXS and NXP AC drive with flange, FR7 and FR8

**Table 13: Dimensions in mm (in inch) of the NXS and NXP AC drive with flange, FR7 and FR8, part 1**

Drive type	W1	W2	W3	W4	D1	D2	Ø
0075 2-0114 2 0072 5-0105 5 0041 6-0052 6	237 (9.33)	175 (6.89)	270 (10.63)	253 (9.96)	257 (10.12)	117 (4.61)	6.5 (0.26)
0140 2-0205 2 0140 5-0205 5 0062 6-0100 6	289 (11.38)	- (-)	355 (13.98)	330 (12.99)	344 (13.54)	110 (4.33)	9 (0.35)

**Table 14: Dimensions in mm (in inch) of the NXS and NXP AC drive, FR7 and FR8, part 2**

Drive type	H1	H2	H3	H4	H5	H6	H7
0075 2-0114 2 0072 5-0105 5 0041 6-0052 6	652 (25.67)	632 (24.88)	630 (24.80)	188.5 (7.42)	188.5 (7.42)	23 (0.91)	20 (0.79)
0140 2-0205 2 0140 5-0205 5 0062 6-0100 6	832* (32.76*)	- (-)	759 (29.88)	258 (10.16)	265 (10.43)	43 (1.69)	57 (2.24)

\* = The brake resistor terminal box (202.5 mm [7.97 in]) and conduit box (68 mm [2.68 in]) are not included, see 5.7 Cable installation for illustrations of these.

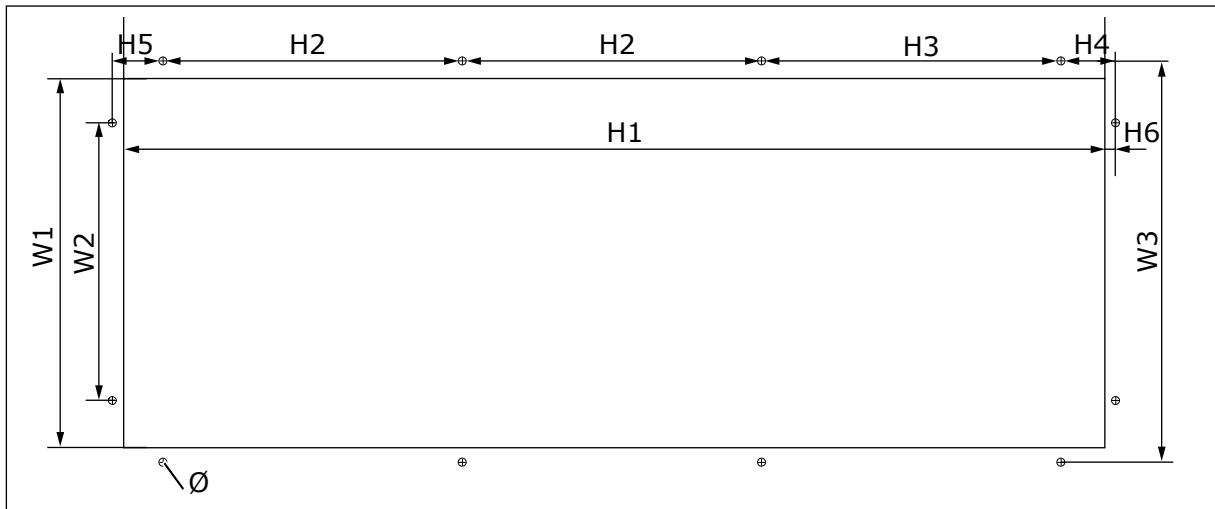

Fig. 12: The dimensions of the opening and drive outline with flange, FR7

Table 15: The dimensions in mm (in inch) of the opening and drive outline with flange, FR7

Drive type	W1	W2	W3	H1	H2	H3	H4	H5	H6	Ø
0075 2-0114 2	233	175	253	619	188.5	188.5	34.5	32	7	5.5
0072 5-0105 5	(9.17)	(6.89)	(9.96)	(24.4)	(7.42)	(7.42)	(1.36)	(1.26)	(0.28)	(0.22)
0041 6-0052 6										

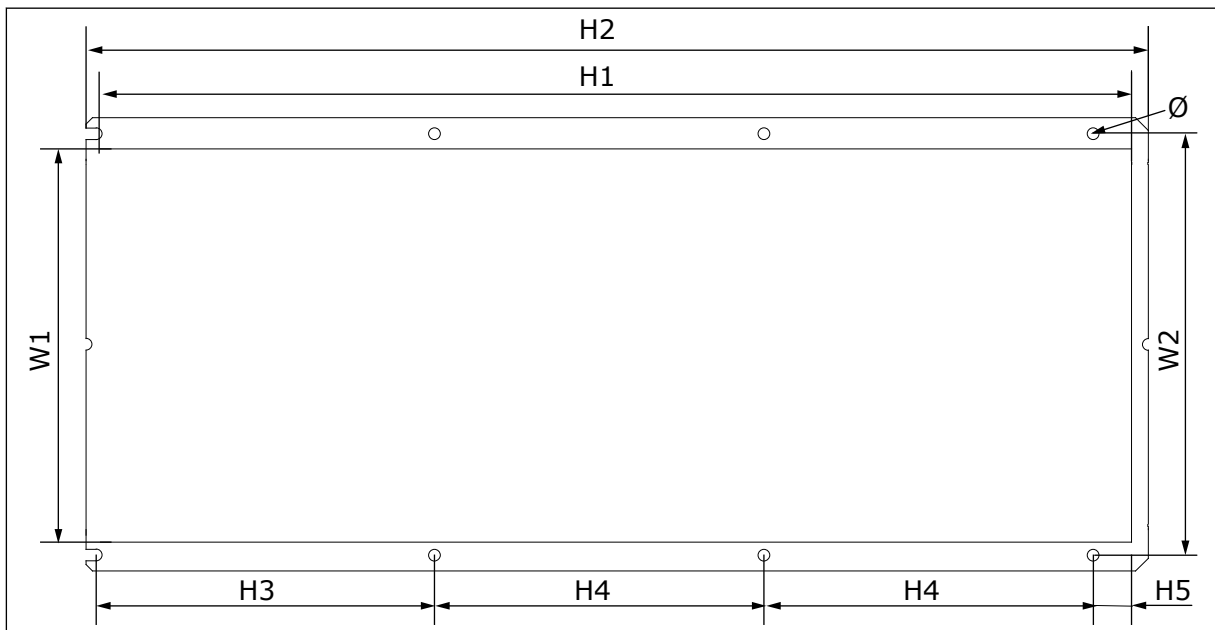
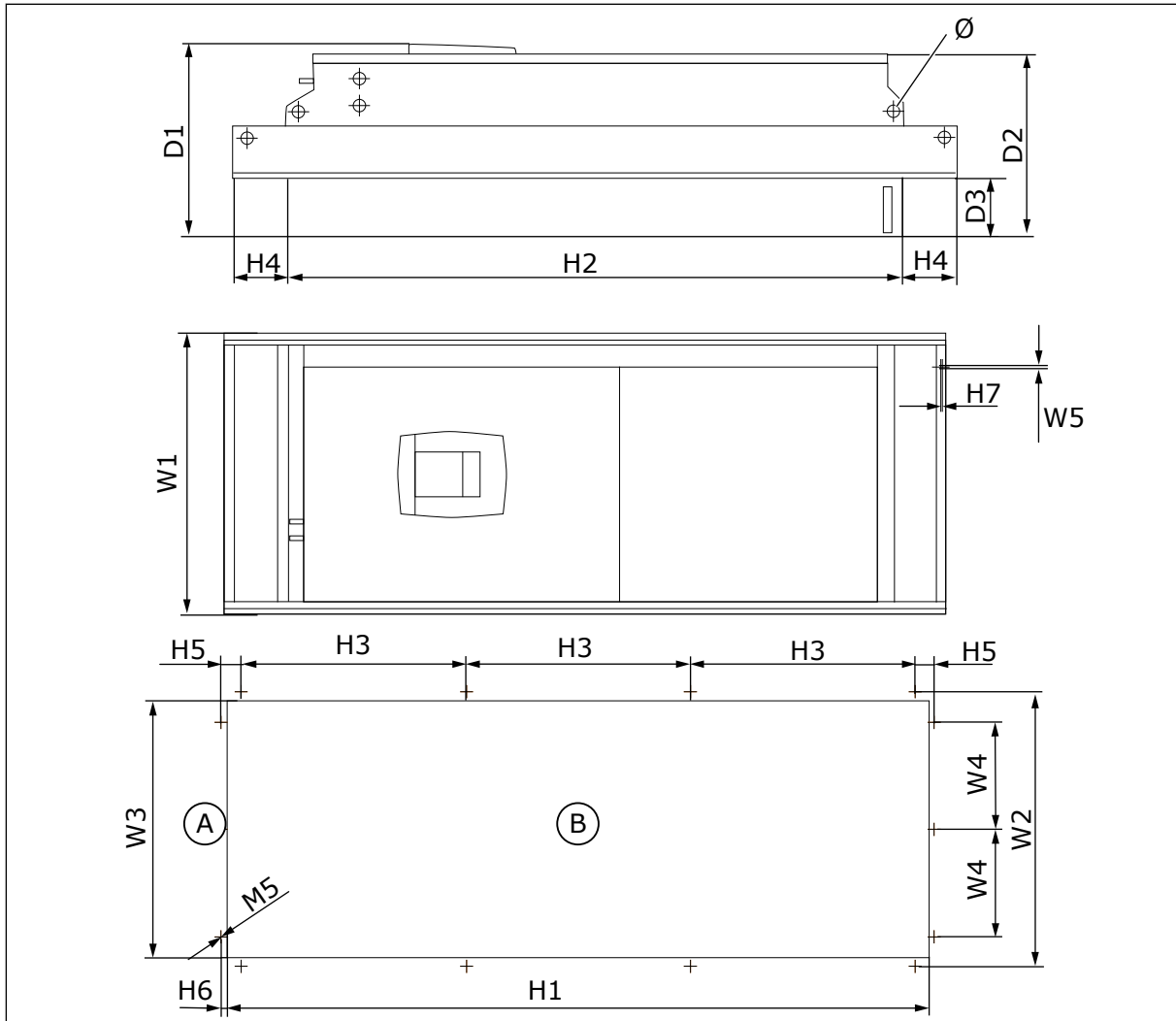

Fig. 13: The dimensions of the opening and drive outline with flange, FR8

**Table 16: The dimensions in mm (in inch) of the opening and drive outline with flange, FR8**

Drive type	W1	W2	H1	H2	H3	H4	H5	∅
0140 2-0205 2	301	330	810	832	265	258	33	9
0140 5-0205 5	[11.85]	[12.99]	[31.89]	[32.76]	[10.43]	[10.16]	[1.30]	[0.35]
0062 6-0100 6								

**4.3.3 FLANGE MOUNTING OF FR9****Fig. 14: Dimensions of the NXS and NXP AC drive, F9**

A. Top

B. Opening

**Table 17: Dimensions in mm (in inch) of the NXS and NXP AC drive, FR9, part 1**

Drive type	W1	W2	W3	W4	W5	D1	D2	D3	∅
0261 2-0300 2	530	510	485	200	5.5	362	340	109	21
0261 5-0300 5	[20.87]	[20.08]	[19.09]	[7.87]	[0.22]	[14.25]	[13.39]	[4.29]	[0.83]
0125 6-0208 6									

**Table 18: Dimensions in mm (in inch) of the NXS and NXP AC drive, FR9, part 2**

Drive type	H1	H2	H3	H4	H5	H6	H7
0261 2-0300 2 0261 5-0300 5 0125 6-0208 6	1312 (51.65)	1150 (45.28)	420 (16.54)	100 (3.94)	35 (1.38)	9 (0.35)	2 (0.08)

#### 4.4 DIMENSIONS FOR STANDALONE

##### 4.4.1 STANDALONE (FR10 AND FR11)

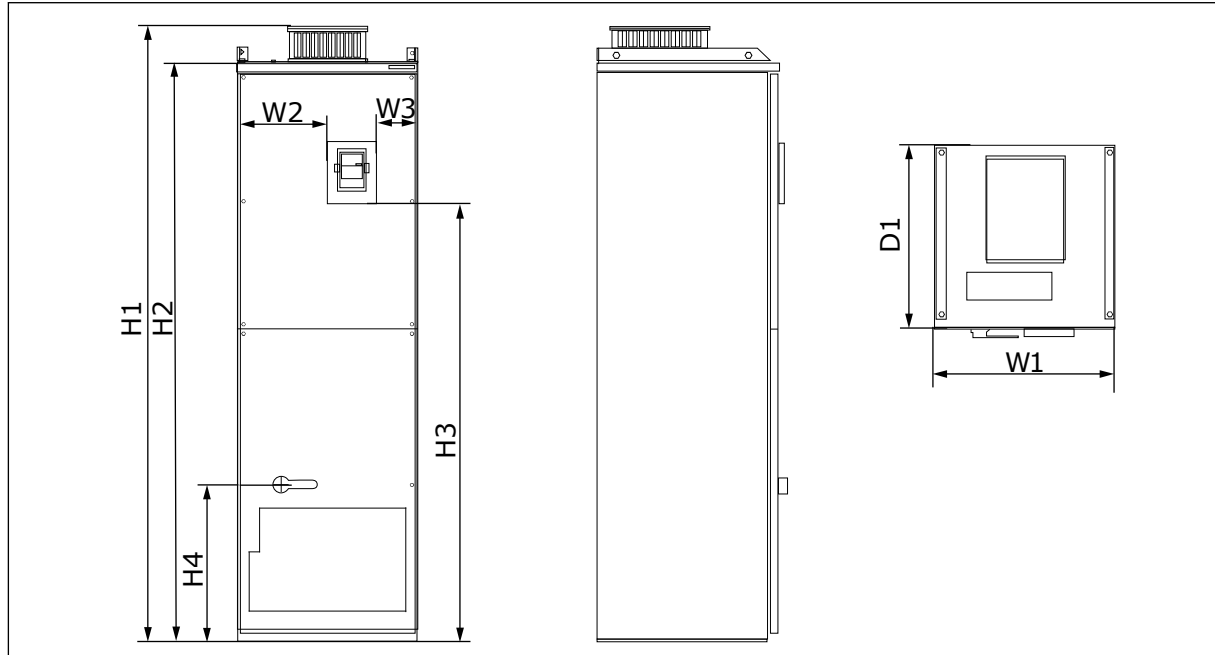

*Fig. 15: Dimensions of the NXS and NXP AC drive, FR10 and FR11*

**Table 19: Dimensions in mm (in inch) of the NXS and NXP AC drive, FR10 and FR11**

Drive type	W1	W2	W3	H1	H2	H3	H4	D1
0385 5-0520 5 0261 6-0416 6	595 (23.43)	291 (11.46)	131 (5.16)	2018 (79.45)	1900 (74.8)	1435 (56.5)	512 (20.16)	602 (23.70)
0590 5-0730 5 0460 6-0590 6	794 (31.26)	390 (15.35)	230 (9.06)	2018 (79.45)	1900 (74.80)	1435 (56.5)	512 (20.16)	602 (23.70)

#### 4.5 COOLING

The AC drive produces heat in operation. The fan moves air and decreases the temperature of the drive. Make sure that there is sufficiently free space around the drive. Some free space is also necessary for maintenance.

If many AC drives are installed above each other, the necessary free space is  $C + D$  (see Fig. 16 *Installation space*). You must also make sure that the outlet air from the lower drive goes to a different direction than the air intake of the top drive.

Make sure that the temperature of the cooling air does not go above the maximum ambient operating temperature or below the minimum ambient operating temperature of the drive.

#### 4.5.1 COOLING OF FR4 TO FR9

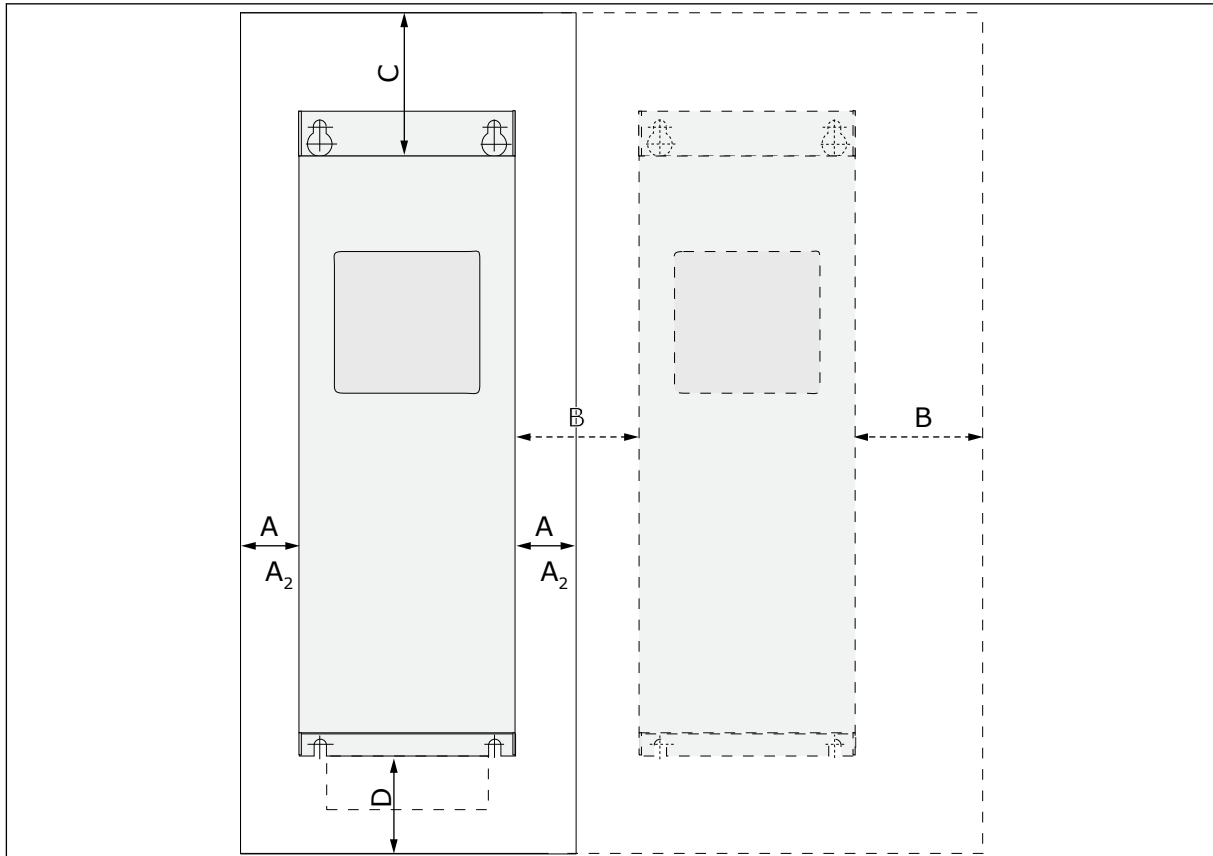

Fig. 16: *Installation space*

- A. The clearance around the drive (see also B and C)
- B. The distance from a drive to a second drive, or the distance to the cabinet wall
- C. The free space above the drive
- D. The free space below the drive

**Table 20: The minimum clearances around the AC drive**

Drive type	Dimensions [mm]				Dimensions [inch]			
	A	B	C	D	A	B	C	D
0003 2-0012 2 0003 5-0012 5	20	20	100	50	0.79	0.79	3.94	1.97
0017 2-0031 2 0016 5-0031 5	20	20	120	60	0.79	0.79	4.72	2.36
0048 2-0061 2 0038 5-0061 5 0004 6-0034 6	30	20	160	80	1.18	0.79	6.30	3.15
0075 2-0114 2 0072 5-0105 5 0041 6-0052 6	80	80	300	100	3.15	3.15	11.81	3.94
0140 2-0205 2 0140 5-0205 5 0062 6-0100 6	80 *	80	300	200	3.15	3.15	11.81	7.87
0261 2-0300 2 0261 5-0300 5 0125 6-0208 6	50	80	400	250 (350**)	1.97	3.15	15.75	9.84 (13.78**)

\* = To change the fan with the motor cables connected, the necessary clearance on the 2 sides of the drive is 150 mm (5.91 inch).

\*\* = The minimum clearance to change the fan.

**Table 21: The necessary quantity of cooling air**

Drive type	The quantity of cooling air [m <sup>3</sup> /h]	The quantity of cooling air [CFM]
0003 2-0012 2 0003 5-0012 5	70	41.2
0017 2-0031 2 0016 5-0031 5 0004 6-0013 6	190	112
0048 2-0061 2 0038 5-0061 5 0018 6-0034 6	425	250
0075 2-0114 2 0072 5-0105 5 0041 6-0052 6	425	250
0140 2-0205 2 0140 5-0205 5 0062 6-0100 6	650	383
0261 2-0300 2 0261 5-0300 5 0125 6-0208 6	1000	589

#### 4.5.2 COOLING OF STANDALONE AC DRIVES (FR10 TO FR11)

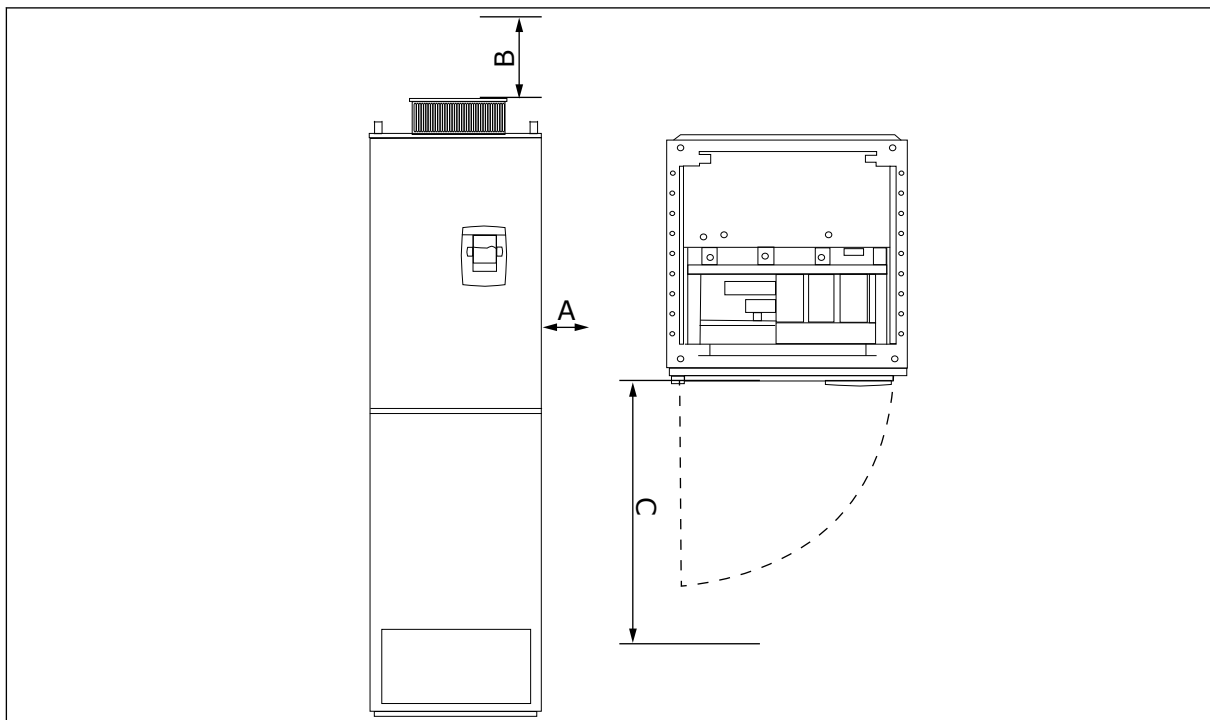

Fig. 17: The minimum clearances around the AC drive

- A. The minimum distance to the side walls or adjacent components
- B. The minimum distance from the top of the cabinet
- C. Free space in front of the cabinet

**Table 22: The minimum clearances around the AC drive**

Installation space dimensions [mm]			Installation space dimensions [in]		
A	B	C	A	B	C
20	200	800	0.79	7.87	31.50

**Table 23: The necessary quantity of cooling air**

Drive type	The quantity of cooling air [m <sup>3</sup> /h]	The quantity of cooling air [CFM]
0385 5-0520 5 0261 6-0416 6	2000	900
0590 5-0730 5 0460 6-0590 6	3000	1765

For more information on the power losses based on the switching frequency, see Chapter 11 Appendix 1.

#### 4.6 HIGH ALTITUDE INSTALLATIONS

The density of air decreases when the altitude increases and the pressure decreases. When the air density decreases, the thermal capacity decreases (i.e. less air removes less heat) and the resistance to electric field (breakdown voltage / distance) decreases.

The full thermal performance of VACON® NX AC drives is designed for installation up to 1000 m altitude and the electric insulation is designed for installations up to 2000 m altitude.

Higher installation locations are possible, when you obey the derating guidelines in this chapter.

Above 1000 m, you must decrease the limited maximum load current by 1% for each 100 m. Thus, for example, at 2500 m altitude, you must decrease the load current down to 85% of the rated output current (100% – (2500 m – 1000 m) / 100 m x 1% = 85%).

When you use fuses at high altitudes, the cooling effect of the fuse decreases as the density of the atmosphere decreases.

When you use fuses above 2000 meters, the continuous rating of the fuse:

$$I = I_n * (1 - (h - 2000) / 100 * 0.5 / 100)$$

Where

I = Current rating at high altitude

I<sub>n</sub> = Rated current of a fuse

h = Altitude in meters





Fig. 18: Loadability in high altitudes

A. Loadability

For permitted maximum altitudes, see chapter 9.2 VACON® NXS and NXP - technical data.

For information on option boards and I/O signals and relay outputs, see VACON® NX I/O Boards User Manual.

## 5 POWER CABLING

### 5.1 CABLE CONNECTIONS

The mains cables are connected to terminals L1, L2 and L3. The motor cables are connected to terminals U, V and W.

To comply with the EMC levels, use a cable entry gland when you install the motor cable at the two ends. For cable selections in different EMC levels, see *Table 24*.

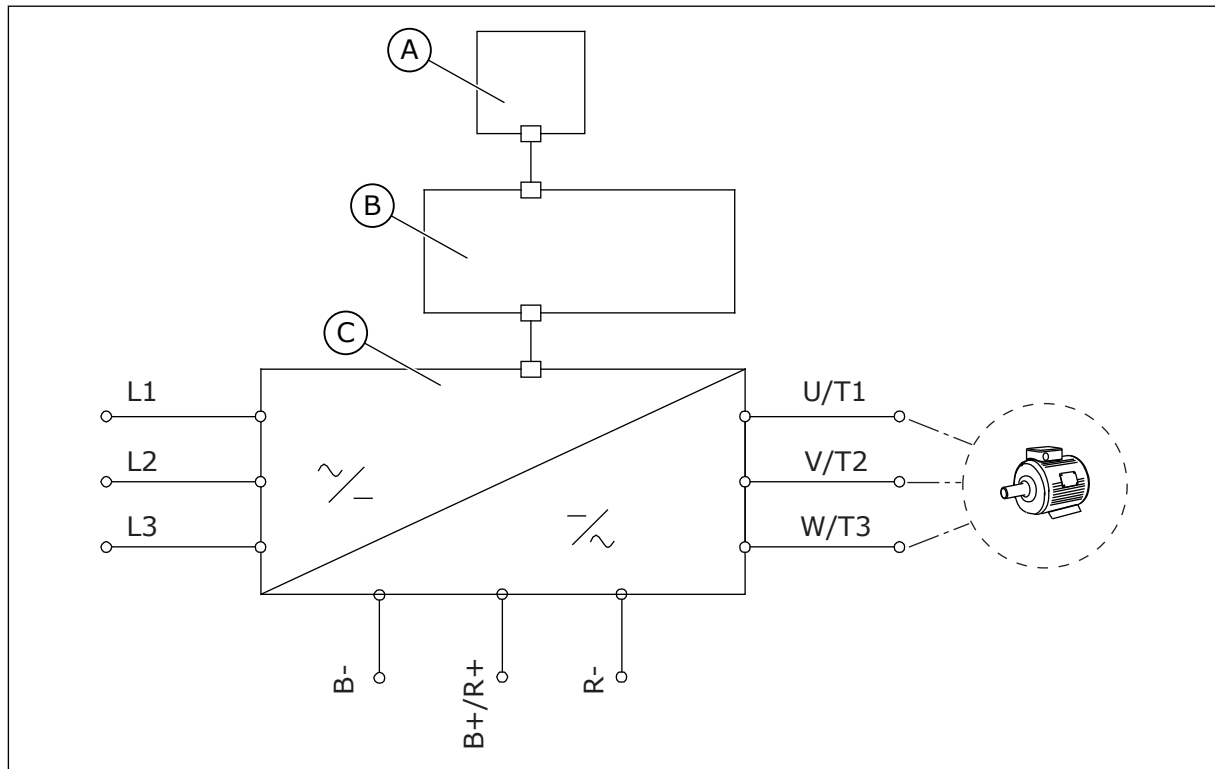

Fig. 19: The principal connection diagram

- A. The control panel  
 B. The control unit  
 C. The power unit

Use cables with a minimum heat resistance of +70 °C (158 °F). In the selection of the cables and the fuses, refer to the nominal **output** current of the drive. You can find the nominal output current on the nameplate.

We recommend that you select the cables and the fuses to agree with the output current because the input current of the AC drive is almost the same as the output current.

For information on how to make the cable installation to comply with the UL standards, see Chapter 5.2 *UL standards on cabling*.

Chapter 5.3 *Cable dimensioning and selection* shows the minimum dimensions of the Cu-cables and the related fuse sizes.

If the motor temperature protection of the drive (see VACON® All in One Application Manual) is used as an overload protection, select the cable to agree with the protection. If 3 or more

cables are used in parallel for larger AC drives, you must use a separate overload protection for each cable.

These instructions are valid only for processes that have 1 motor and 1 cable connection from the AC drive to the motor. In other conditions, speak to the manufacturer to get more information.

**Table 24: The selection of the correct cable**

Cable type	EMC requirements			
	1st environment	2nd environment		
	Category C1 and C2	Category C3	Category C4	No EMC protection
The mains cable	1	1	1	1
The motor cable	3 *	2	2	2
The control cable	4	4	4	4

1. A power cable for a fixed installation. A cable for the specified mains voltage. A shielded cable is not necessary. We recommend an NKCABLES/MCMK cable.
2. A symmetrical power cable with a concentric protection wire. A cable for the specified mains voltage. We recommend an NKCABLES/MCMK cable. See Fig. 20.
3. A symmetrical power cable with a compact low-impedance shield. A cable for the specified mains voltage. We recommend an NKCABLES /MCCMK, SAB/ÖZCUY-J or equivalent cable. See Fig. 20. \* = For the EMC levels C1 and C2, it is necessary to have a 360° grounding of the shield with cable glands in the motor end.
4. A screened cable with a compact low-impedance shield, for example an NKCABLES/JAMAK, or an SAB/ÖZCuY-0 cable.

For the definitions of EMC protection levels, see Chapter 9.3 *The compliance with the product standard IEC/EN 61800-3 + A1*.

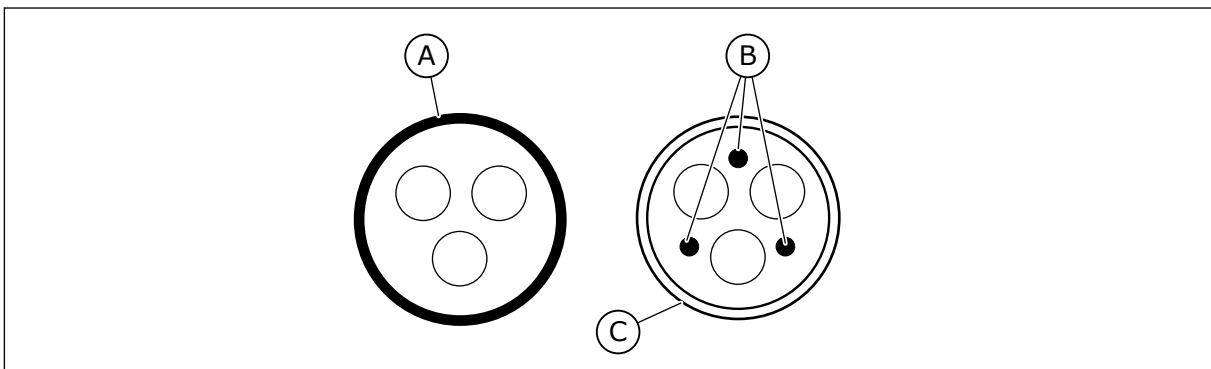

*Fig. 20: Cables with PE conductors*

- A. The PE conductor and the shield  
 B. The PE conductors  
 C. The shield

In all the enclosure sizes, to comply with the EMC standards, use the default values of the switching frequencies.

If you installed a safety switch, make sure that the EMC protection continues from the start of the cables until their ends.

## 5.2 UL STANDARDS ON CABLING

To comply with the UL (Underwriters Laboratories) regulations, use a UL-approved copper wire with a minimum heat resistance of 60 or 75 °C (140 or 167 °F). To comply with the standards, use cables with +90 °C (194 °F) heat resistance for sizes 0170 2 and 0168 5 (FR8), and 0261 2, 0261 5, 0300 2 and 0300 5 (FR9).

Use Class 1 wire only.

When the drive has Class T and J fuses, you can use it on a circuit that gives a maximum of 100 000 rms symmetrical amperes, and a maximum of 600 V.

The integral solid state short circuit protection does not give a branch circuit protection. Obey the National Electric Code and any additional local codes to get the branch circuit protection. Only fuses give the branch circuit protection.

For the tightening torques of the terminals, see *Table 36 The tightening torques of the terminals* and *Table 39 Tightening torques of the terminals*.

## 5.3 CABLE DIMENSIONING AND SELECTION

We recommend the fuse type gG/gL (IEC 60269-1). To make a selection of the fuse voltage rating, refer to the mains. Do not use larger fuses than what is recommended.

Make sure that the operation time of the fuse is less than 0.4 seconds. The operation time agrees with the fuse type and the impedance of the supply circuit. For more information on faster fuses, speak to the manufacturer. The manufacturer can also recommend some aR (UL recognised, IEC 60269-4) and gS (IEC 60269-4) fuse ranges.

The tables show the typical sizes and types of cables that you can use with the AC drive. In the selection of cables, refer to local regulations, cable installation conditions and cable specification.

### **The dimensions of the cables must comply with the requirements of the standard IEC60364-5-52.**

- The cables must be PVC-isolated.
- The maximum ambient temperature is +30 °C (86 °F).
- The maximum temperature of the cable surface is +70 °C (158 °F).
- Use only cables with a concentric copper shield.
- The maximum number of parallel cables is 9.

When you use parallel cables, make sure that you obey the requirements of the cross-sectional area and the maximum number of cables.

For important information on the requirements of the grounding conductor, see chapter 2.4 *Grounding and earth fault protection*.

For the correction factors for each temperature, see the standard IEC60364-5-52.

## 5.3.1 CABLE AND FUSE SIZES FOR 208-240 V AND 380-500 V, FR4 TO FR9

**Table 25: The cable and fuse sizes for VACON® NXS and NXP**

Enclosure size	Type	IL [A]	Fuse (gG/gL) [A]	Mains, motor and brake resistor cable Cu 1) [mm <sup>2</sup> ]	Terminal cable size	
					Mains cable terminal [mm <sup>2</sup> ]	Grounding terminal [mm <sup>2</sup> ]
FR4	0003 2—0008 2 0003 5—0009 5	3-8 3-9	10	3*1.5+1.5	1-4	1-4
	0011 2—0012 2 0012 5	11-12 12	16	3*2.5+2.5	1-4	1-4
FR5	0017 2 0016 5	17 16	20	3*4+4	1-10	1-10
	0025 2 0022 5	25 22	25	3*6+6	1-10	1-10
	0031 2 0031 5	31 31	35	3*10+10	1-10	1-10
FR6	0048 2 0038 5—0045 5	48 38-45	50	3*10+10	2.5-50 Cu 6-50 Al	2.5-35
	0061 2 0061 5	61	63	3*16+16	2.5-50 Cu 6-50 Al	2.5-35
FR7	0075 2 0072 5	75 72	80	3*25+16	2.5-50 Cu 6-50 Al	6-70
	0088 2 0087 5	88 87	100	3*35+16	2.5-50 Cu 6-50 Al	6-70
	0114 2 0105 5	114 105	125	3*50+25	2.5-50 Cu 6-50 Al	6-70
FR8	0140 2 0140 5	140	160	3*70+35	25-95 Cu/Al	6-95
	0170 2 0168 5	168	200	3*95+50	95-185 Cu/Al	6-95
	0205 2 0205 5	205	250	3*150+70	95-185 Cu/Al	6-95
FR9	0261 2 0261 5	261	315	3*185+95 or 2*(3*120+70)	95-185 Cu/Al	6-95
	0300 2 0300 5	300	315	2*(3*120+70)	95-185 Cu/Al	6-95

1) = uses a correction factor 0.7

**Table 26: The cable and fuse sizes for VACON® NXS and NXP, North America**

Enclosure size	Type	Fuse Class Fast Acting (T/J) [A]	Mains, Motor and brake resistor cable Cu 1) 2) [AWG]	Terminal cable size	
				Mains cable terminal [AWG]	Grounding terminal [AWG]
FR4	0003 2—0008 2 0003 5—0007 5	10	3*16 AWG + 16 AWG	18 AWG - 4 AWG	18 AWG - 4 AWG
	0009 5	15	3*16 AWG + 16 AWG	18 AWG - 4 AWG	18 AWG - 4 AWG
	0011 2—0012 2 0012 5	15	3*14 AWG + 14 AWG	18 AWG - 4 AWG	18 AWG - 4 AWG
FR5	0017 2 0016 5	20	3*12 AWG + 12 AWG	18 AWG - 8 AWG	18 AWG - 8 AWG
	0025 2 0022 5	30	3*10 AWG + 10 AWG	18 AWG - 8 AWG	18 AWG - 8 AWG
	0031 2 0031 5	40	3*8 AWG + 8 AWG	18 AWG - 8 AWG	18 AWG - 8 AWG
FR6	0038 5	50	3*8 AWG + 8 AWG	14 AWG - 1 AWG Cu 10 AWG - 1 AWG Al	14 AWG - 2 AWG
	0048 2 0045 5	60	3*8 AWG + 8 AWG	14 AWG - 1 AWG Cu 10 AWG - 1 AWG Al	14 AWG - 2 AWG
	0061 2 0061 5	90	3*6 AWG + 6 AWG	14 AWG - 1 AWG Cu 10 AWG - 1 AWG Al	14 AWG - 2 AWG
FR7	0075 2 0072 5	90	3*4 AWG + 6 AWG	14 AWG - 1 AWG Cu 10 AWG - 1 AWG Al	10 AWG - 2/0 AWG
	0088 2 0087 5	110	3*2 AWG + 6 AWG	14 AWG - 1 AWG Cu 10 AWG - 1 AWG Al	10 AWG - 2/0 AWG
	0114 2 0105 5	150	3*2 AWG + 4 AWG	14 AWG - 1 AWG Cu 10 AWG - 1 AWG Al	10 AWG - 2/0 AWG
FR8	0140 2 0140 5	175	3*2/0 AWG + 2 AWG	4 AWG - 3/0 AWG Cu/Al	10 AWG - 3/0 AWG
	0170 2 0168 5	250	3*3/0 AWG + 1/0 AWG	3/0 AWG - 350kcmil Cu/Al	10 AWG - 3/0 AWG
	0205 2 0205 5	250	3*300kcmil + 2/0 AWG	3/0 AWG - 350kcmil Cu/Al	10 AWG - 3/0 AWG
FR9	0261 2 0261 5	350	3*350kcmil + 3/0 AWG 2*(3*250kcmil + 2/0 AWG)	3/0 AWG - 350kcmil Cu/Al	10 AWG - 3/0 AWG
	0300 2 0300 5	400	2*(3*250kcmil + 2/0 AWG)	3/0 AWG - 350kcmil Cu/Al	10 AWG - 3/0 AWG

1) = Use cables with a +90 °C (194 °F) heat resistance to comply with the UL standards.

2) = uses a correction factor 0.7

## 5.3.2 CABLE AND FUSE SIZES FOR 525-690 V, FR6 TO FR9

**Table 27: The cable and fuse sizes for VACON® NXS and NXP**

Enclosure size	Type	IL [A]	Fuse (gG/gL) [A]	Mains, motor and brake resistor cable Cu <sup>1)</sup> [mm <sup>2</sup> ]	Terminal cable size	
					Mains cable terminal [mm <sup>2</sup> ]	Grounding terminal [mm <sup>2</sup> ]
FR6	0004 6—0007 6	3-7	10	3*2.5+2.5	2.5-50 Cu 6-50 Al	2.5-35
	0010 6—0013 6	10-13	16	3*2.5+2.5	2.5-50 Cu 6-50 Al	2.5-35
	0018 6	18	20	3*4+4	2.5-50 Cu 6-50 Al	2.5-35
	0022 6	22	25	3*6+6	2.5-50 Cu 6-50 Al	2.5-35
	0027 6—0034 6	27-34	35	3*10+10	2.5-50 Cu 6-50 Al	2.5-35
FR7	0041 6	41	50	3*10+10	2.5-50 Cu 6-50 Al	6-50
	0052 6	52	63	3*16+16	2.5-50 Cu 6-50 Al	6-50
FR8	0062 6—0080 6	62-80	80	3*25+16	25-95 Cu/Al	6-95
	0100 6	100	100	3*35+16		
FR9	0125 6—0144 6 0170 6	125-144 170	160 200	3*95+50	95-185 Cu/Al2	6-95
	0208 6	208	250	3*150+70		

<sup>1)</sup> uses a correction factor 0.7

**Table 28: The cable and fuse sizes for VACON® NXS and NXP, North America, UL rating 525-600 V**

Enclosure size	Type	Fuse Class Fast Acting (T/J) [A]	Mains, Motor and brake resistor cable Cu 1)[AWG]2)	Terminal cable size	
				Mains cable terminal [AWG]	Grounding terminal [AWG]
FR6	0004 6—0007 6	10	3*14 AWG + 14 AWG	14 AWG - 1 AWG Cu 10 AWG - 1 AWG Al	14 AWG - 2 AWG
	0010 6	15	3*14 AWG + 14 AWG	14 AWG - 1 AWG Cu 10 AWG - 1 AWG Al	14 AWG - 2 AWG
	0013 6	20	3*14 AWG + 14 AWG	14 AWG - 1 AWG Cu 10 AWG - 1 AWG Al	14 AWG - 2 AWG
	0018 6	25	3*12 AWG + 12 AWG	14 AWG - 1 AWG Cu 10 AWG - 1 AWG Al	14 AWG - 2 AWG
	0022 6	30	3*10 AWG + 10 AWG	14 AWG - 1 AWG Cu 10 AWG - 1 AWG Al	14 AWG - 2 AWG
	0027 6	40	3*8 AWG + 8 AWG	14 AWG - 1 AWG Cu 10 AWG - 1 AWG Al	14 AWG - 2 AWG
	0034 6	50	3*8 AWG + 8 AWG	14 AWG - 1 AWG Cu 10 AWG - 1 AWG Al	14 AWG - 2 AWG
FR7	0041 6	50	3*8 AWG + 8 AWG	14 AWG - 1 AWG Cu 10 AWG - 1 AWG Al	10 AWG - 1 AWG
	0052 6	70	3*6 AWG + 6 AWG	14 AWG - 1 AWG Cu 10 AWG - 1 AWG Al	10 AWG - 1 AWG
FR8	0062 6	80	3*4 AWG + 6 AWG	4 AWG - 3/0 AWG Cu/Al	10 AWG - 3/0 AWG
	0080 6	100	3*4 AWG + 6 AWG	4 AWG - 3/0 AWG Cu/Al	10 AWG - 3/0 AWG
	0100 6	125	3*2 AWG + 6 AWG	4 AWG - 3/0 AWG Cu/Al	10 AWG - 3/0 AWG
FR9	0125 6—0144 6	200	3*3/0 AWG + 1/0 AWG	3/0 AWG - 350kcmil Cu/Al	10 AWG - 3/0 AWG
	0170 6	250	3*3/0 AWG + 1/0 AWG	3/0 AWG - 350kcmil Cu/Al	10 AWG - 3/0 AWG
	0208 6	300	3*300kcmil + 2/0 AWG	3/0 AWG - 350kcmil Cu/Al	10 AWG - 3/0 AWG

1) Use cables with a +90 °C (194 °F) heat resistance to comply with the UL standards.

2) uses a correction factor 0.7



## 5.3.3 CABLE AND FUSE SIZES FOR 380-500 V, FR10 TO FR11

**Table 29: The cable and fuse sizes for VACON® NXS and NXP**

Enclosure size	Type	IL [A]	Fuse (gG/gL) [A]	Mains, motor and brake resistor cable 1) [mm <sup>2</sup> ]	Number of supply cables	Number of motor cables
FR10	0385 5	385	400 (3 pcs)	Cu: 2*(3*120+70) Al: 2*(3*185Al+57Cu)	Even/Odd	Even/Odd
	0460 5	460	500 (3 pcs)	Cu: 2*(3*150+70) Al: 2*(3*240Al+72Cu)	Even/Odd	Even/Odd
	0520 5	520	630 (3 pcs)	Cu: 2*(3*185+95) Al: 2*(3*300Al+88Cu)	Even/Odd	Even/Odd
FR11	0590 5	590	315 (6 pcs)	Cu: 2*(3*240+120) Al: 4*(3*120Al+41Cu)	Even	Even/Odd
	0650 5	650	400 (6 pcs)	Cu: 4*(3*95+50) Al: 4*(3*150Al+41Cu)	Even	Even/Odd
	0730 5	730	400 (6 pcs)	Cu: 4*(3*150+70) Al: 4*(3*185Al+57Cu)	Even	Even/Odd

1) uses a correction factor 0.7

**Table 30: The cable and fuse sizes for VACON® NXS and NXP, North America**

Enclosure size	Type	Fuse Class Fast Acting (T/J) [A]	Mains, Motor and brake resistor cable Cu 1)[AWG] <sup>2)</sup>	Number of supply cables	Number of motor cables
FR10	0385 5	500 (3 pcs)	Cu: 2*(3*250kcmil + 2/0 AWG) Al: 2*(3*350kcmil Al + 1/0 AWG Cu)	Even/Odd	Even/Odd
	0460 5	600 (3 pcs)	Cu: 2*(3*300kcmil + 2/0 AWG) Al: 2*(3*500kcmil Al + 2/0 Cu AWG)	Even/Odd	Even/Odd
	0520 5	700 (3 pcs)	Cu: 2*(3*350kcmil + 3/0 AWG) Al: 2*(3*600kcmil Al + 3/0 AWG Cu)	Even/Odd	Even/Odd
FR11	0590 5	400 (6 pcs)	Cu: 2*(3*500kcmil + 250kcmil) Al: 4*(3*250kcmil Al + 1 AWG Cu)	Even	Even/Odd
	0650 5	400 (6 pcs)	Cu: 4*(3*3/0 AWG + 1/0 AWG) Al: 4*(3*300kcmil Al + 1 AWG Cu)	Even	Even/Odd
	0730 5	500 (6 pcs)	Cu: 4*(3*300kcmil + 2/0 AWG) Al: 4*(3*350kcmil Al + 1/0 AWG Cu)	Even	Even/Odd

1) Use cables with a +90 °C (194 °F) heat resistance to comply with the UL standards.

2) uses a correction factor 0.7

## 5.3.4 CABLE AND FUSE SIZES FOR 525-690 V, FR10 TO FR11

**Table 31: The cable and fuse sizes for VACON® NXS and NXP**

Enclosure size	Type	I <sub>L</sub> [A]	Fuse (gG/gL) [A]	Mains, motor and brake resistor cable 1) [mm <sup>2</sup> ]	Number of supply cables	Number of motor cables
FR10	0261 6	261	315 (3 pcs)	Cu: 3*185+95 Al: 2*(3*95Al+29Cu)	Even/Odd	Even/Odd
	0325 6	325	400 (3 pcs)	Cu: 2x(3*95 + 50) Al: 2*(3*150Al+41Cu)	Even/Odd	Even/Odd
	0385 6	385	400 (3 pcs)	Cu: 2*(3*120+70) Al: 2*(3*185Al+57Cu)	Even/Odd	Even/Odd
	0416 6	416	500 (3 pcs)	Cu: 2*(3*150+70) Al: 2*(3*185Al+57Cu)	Even/Odd	Even/Odd
FR11	0460 6	460	500 (3 pcs)	Cu: 2*(3*150+70) Al: 2*(3*240Al+72Cu)	Even/Odd	Even/Odd
	0502 6	502	630 (3 pcs)	Cu: 2*(3*185+95) Al: 2*(3*300Al+88 Cu)	Even/Odd	Even/Odd
	0590 6	590	315 (6 pcs)	Cu: 2*(3*240+120) Al: 4*(3*120Al+41Cu)	Even	Even/Odd

1) uses a correction factor 0.7

**Table 32: The cable and fuse sizes for VACON® NXS and NXP, North America**

Enclosure size	Type	Fuse Class Fast Acting (T/J) [A]	Mains, Motor and brake resistor cable Cu 1)[AWG]2)	Number of supply cables	Number of motor cables
FR10	0261 6	350 (3 pcs)	Cu: 3*350kcmil + 3/0 AWG Al: 2*(3*3/0 AWG Al + 2 AWG Cu)	Even/Odd	Even/Odd
	0325 6	400 (3 pcs)	Cu: 2*(3*3/0 AWG + 1/0 AWG) Al: 2*(3*300kcmil Al + 1 AWG Cu)	Even/Odd	Even/Odd
	0385 6	500 (3 pcs)	Cu: 2*(3*250kcmil + 2/0 AWG) Al: 2*(3*350kcmil Al + 1/0 AWG Cu)	Even/Odd	Even/Odd
	0416 6	500 (3 pcs)	Cu: 2*(3*300kcmil + 2/0 AWG) Al: 2*(3*350kcmil Al + 1/0 AWG Cu)	Even/Odd	Even/Odd
FR11	0460 6	600 (3 pcs)	Cu: 2*(3*300kcmil + 2/0 AWG) Al: 2*(3*500kcmil Al + 2/0 AWG Cu)	Even/Odd	Even/Odd
	0502 6	700 (3 pcs)	Cu: 2*(3*350kcmil + 3/0 AWG) Al: 2*(3*600kcmil Al + 3/0 AWG Cu)	Even/Odd	Even/Odd
	0590 6	400 (6 pcs)	Cu: 2*(3*500kcmil + kcmil250) Al: 4*(3*250kcmil Al + 1 AWG Cu)	Even	Even/Odd

1) Use cables with a +90 °C (194 °F) heat resistance to comply with the UL standards.

2) uses a correction factor 0.7

## 5.4 UNDERSTANDING THE POWER UNIT TOPOLOGY

The principles for mains and motor connections of the basic 6-pulse drive in enclosure sizes FR4 to FR11 show in *Fig. 21*.

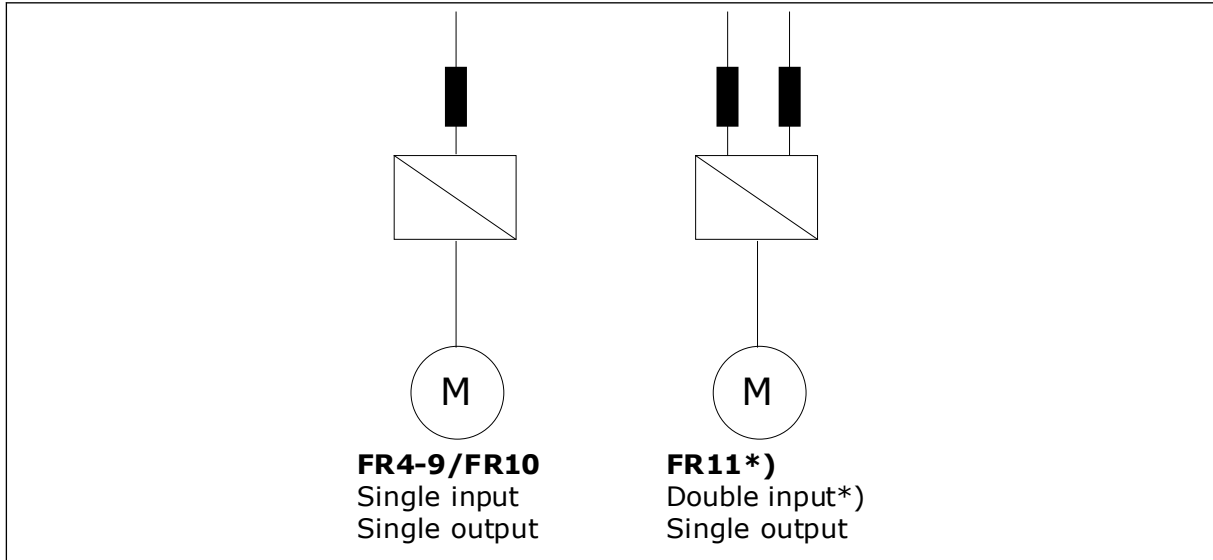

*Fig. 21: Topology of enclosure sizes FR4 – FR11*

\* The FR11 types 0460 6 and 0502 6 have single input terminal.

## 5.5 BRAKE RESISTOR CABLES

VACON® NXS and NXP AC drives have terminals for the DC supply and an optional external brake resistor. These terminals are identified with B-, B+/R+ and R-. The DC bus connection is made to terminals B- and B+ and the brake resistor connection to R+ and R-. You can find the dimensions that we recommend for the brake resistor cables in the tables in Chapter 5.3 *Cable dimensioning and selection*.



### CAUTION!

If you use a multi-conductor cable, cut off all conductors that are not connected to prevent an accidental contact with a conducting component.

See Chapter 9.1.5 *Brake resistor ratings*.



### NOTE!

The enclosure sizes FR8 and larger have the DC connection as optional.



### NOTE!

If it is necessary to connect an external brake resistor, see VACON® Brake Resistor Manual. See also Chapter 7.9.7.1 *Internal brake resistor connection [P6.7.1]*.

## 5.6 PREPARING FOR THE CABLE INSTALLATION

- Before you start, make sure that none of the components of the AC drive is live. Read carefully the warnings in Chapter 2 *Safety*.
- Make sure that the motor cables are sufficiently far from other cables.
- The motor cables must go across other cables at an angle of 90°.
- If it is possible, do not put the motor cables in long parallel lines with other cables.
- If the motor cables are in parallel with other cables, obey the minimum distances (see *Table 33 The minimum distances between cables*).
- The distances are also valid between the motor cables and the signal cables of other systems.
- The maximum lengths of shielded motor cables are 300 m (984 ft) (AC drives with power greater than 1.5 kW or 2 HP), and 100 m (328 ft) (AC drives with power from 0.75 to 1.5 kW or 1 to 2 HP). If the used motor cables are longer than these, speak to the factory to get more information.

 **NOTE!**

Each parallel cable adds to the total length.

 **NOTE!**

If you use long motor cables (max. 100 m or 328 ft) together with small drives ( $\leq 1.5$  kW or  $\leq 2.01$  HP), the capacitive current in the motor cable can increase the measured motor current compared to the actual motor current. Think this when you set up the motor stall protection functions.

- If the cable insulation checks are necessary, see Chapter 8.4 *Measuring the cable and motor insulation* for instructions.

**Table 33: The minimum distances between cables**

The distance between cables [m]	The length of the shielded cable [m]	The distance between cables [ft]	The length of the shielded cable [ft]
0.3	$\leq 50$	1.0	$\leq 164.0$
1.0	$\leq 300$	3.3	$\leq 656.1$

## 5.7 CABLE INSTALLATION

### 5.7.1 ENCLOSURE SIZES FR4 TO FR7

 **NOTE!**

For information on how to comply with the UL regulations in cable installation, see Chapter 5.2 *UL standards on cabling*.

**Table 34: The cable stripping lengths [mm]. See the figure in step 1.**

Enclosure size	A1	B1	C1	D1	A2	B2	C2	D2
FR4	15	35	10	20	7	50	7	35
FR5	20	40	10	30	20	60	10	40
FR6	20	90	15	60	20	90	15	60
FR7	25	120	25	120	25	120	25	120

**Table 35: The cable stripping lengths [in]. See the figure in step 1.**

Enclosure size	A1	B1	C1	D1	A2	B2	C2	D2
FR4	0.59	1.38	0.39	0.79	0.28	1.97	0.28	1.38
FR5	0.79	1.57	0.39	1.18	0.79	2.36	0.79	1.57
FR6	0.79	3.54	0.59	2.36	0.79	3.54	0.59	2.36
FR7	0.98	4.72	0.98	4.72	0.98	4.72	0.98	4.72

**NOTE!**

If it is necessary to connect an external brake resistor, see VACON® Brake Resistor Manual. See also Chapter 7.9.7.1 *Internal brake resistor connection (P6.7.1)*.

- 1 Strip the motor cable, the mains cable, and the brake resistor cable.

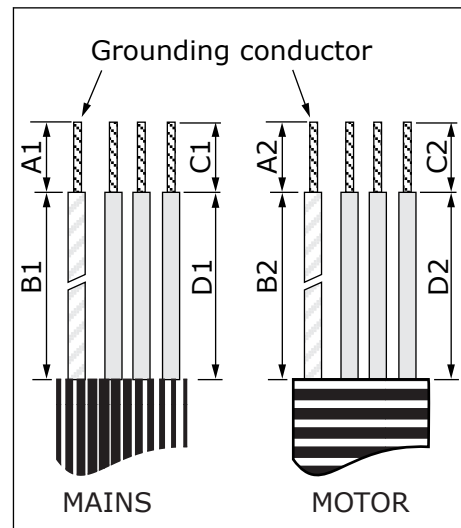

- 2 Open the cover of the AC drive.

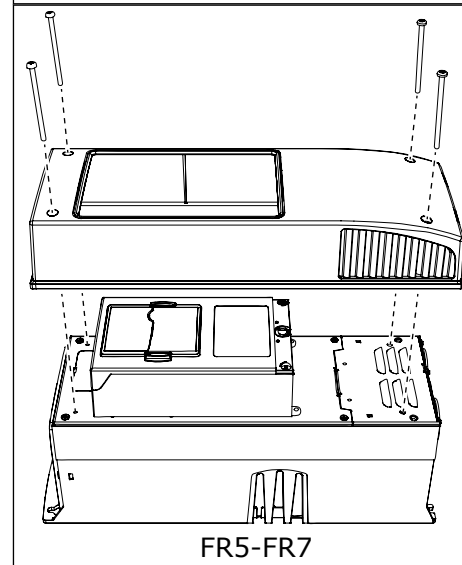
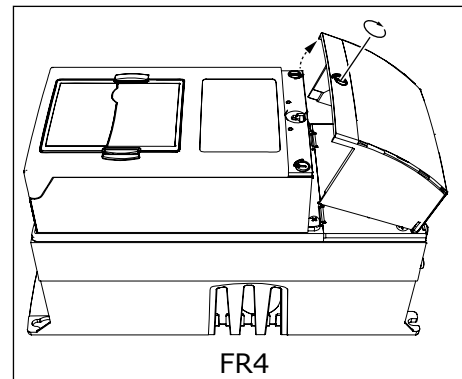

- 3 Remove the screws of the cable cover. Remove the cable cover. Do not open the cover of the power unit.

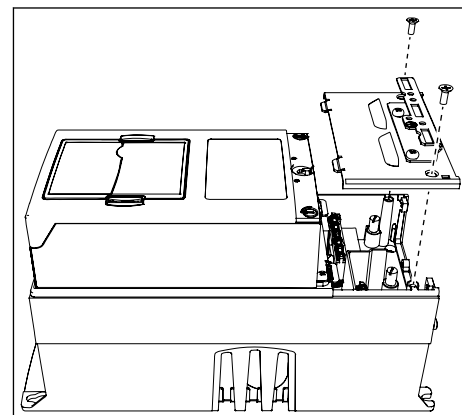

- 4 Put the cables - the mains cable, the motor cable and the optional brake cable - in the openings of the cable entry plate.

**NOTE!**

Use a cable gland as an alternative to the grommet in types where this is necessary.

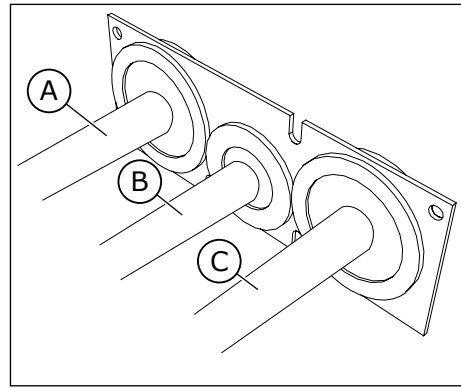

- A. The mains cable  
B. The brake cable  
C. The motor cable

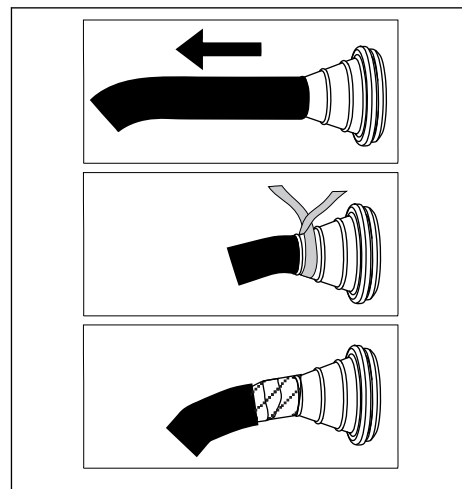

- 5 Remove the grounding clamps for grounding conductor.

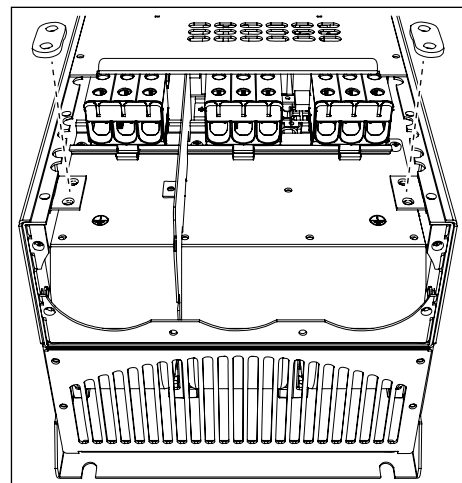

- 6 Put the cable entry plate with the cables into the groove on the frame of the drive.

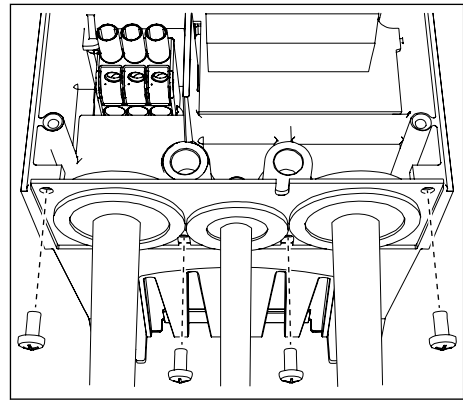



## 7 Connect the cables.

- a) Connect the phase conductors of the mains cable and of the motor cable, and the conductors of the brake resistor cable into the correct terminals.
- b) Attach the grounding conductor of each cable to a grounding terminal with a grounding clamp for grounding conductor.
- c) See the correct tightening torques in *Table 36*.

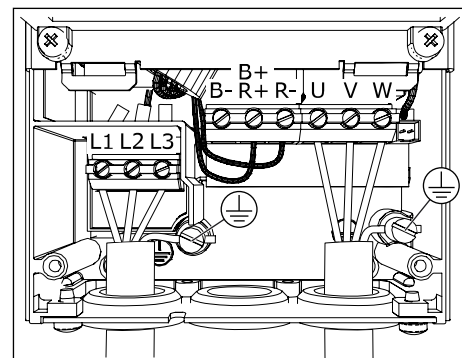

FR4

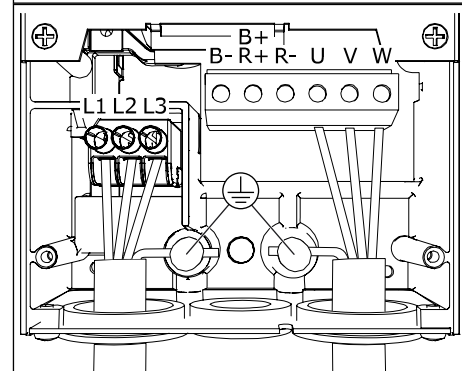

FR5

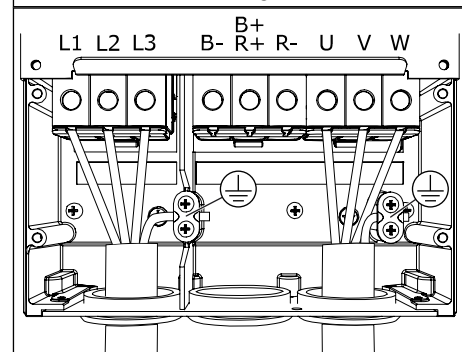

FR6

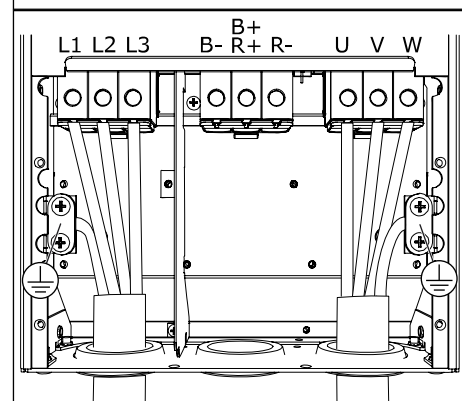

FR7

- 8 Make sure that the grounding conductor is connected to the motor and also to the terminals that are identified with ⊕ .
  - a) For FR4 and FR5: Two protective conductors are necessary to comply with the requirements of the standard IEC/EN 61800-5-1. See Chapter 2.4 *Grounding and earth fault protection*.
  - b) If a double grounding is necessary, use the grounding terminal below the drive. Use an M5 screw and tighten it to 2.0 Nm or 17.7 lb-in.

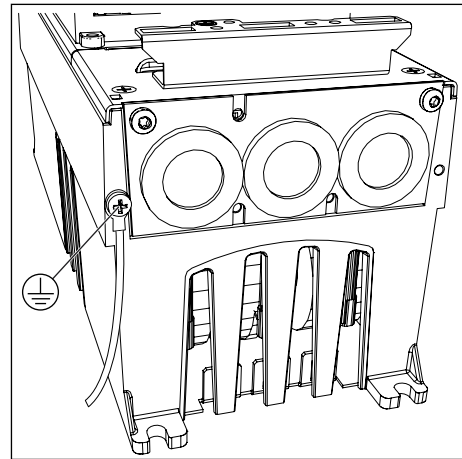

- 9 Attach again the cable cover and the cover of the drive. For the tightening torques of the screws, see *Table 5 The tightening torques of the cover screws*. Make sure that the control cables or the cables of the AC drive are not caught between the frame and the cable cover.

**Table 36: The tightening torques of the terminals**

Enclosure size	Type	Tightening torque: the mains cable and motor cable terminals	
		Nm	lb-in.
FR4	0004 2-0012 2 0003 5-0012 5	0.5-0.6	4.5-5.3
FR5	0017 2-0031 2 0016 5-0031 5	1.2-1.5	10.6-13.3
FR6	0048 2-0061 2 0038 5-0061 5 0004 6-0034 6	10	88.5
FR7	0075 2-0114 2 0072 5-0105 5 0041 6-0052 6	10	88.5

**5.7.2 ENCLOSURE SIZES FR8 TO FR9**



**NOTE!**

For information on how to comply with the UL regulations in cable installation, see Chapter 5.2 *UL standards on cabling*.

**Table 37: The cable stripping lengths [mm]. See the figure in step 1.**

Enclosure size	A1	B1	C1	D1	A2	B2	C2	D2
FR8								
0140	23	240	23	240	23	240	23	240
0168—0205	28	240	28	240	28	240	28	240
FR9	28	295	28	295	28	295	28	295

**Table 38: The cable stripping lengths [in]. See the figure in step 1.**

Enclosure size	A1	B1	C1	D1	A2	B2	C2	D2
FR8								
0140	0.91	9.45	0.91	9.45	0.91	9.45	0.91	9.45
0168—0205	1.10	9.45	1.10	9.45	1.10	9.45	1.10	9.45
FR9	1.10	11.61	1.10	11.61	1.10	11.61	1.10	11.61

**NOTE!**

If you want to connect an external brake resistor, see VACON® Brake Resistor Manual. See also Chapter 7.9.7.1 *Internal brake resistor connection (P6.7.1)*.

- 1 Strip the motor cable, the mains cable, and the brake resistor cable.

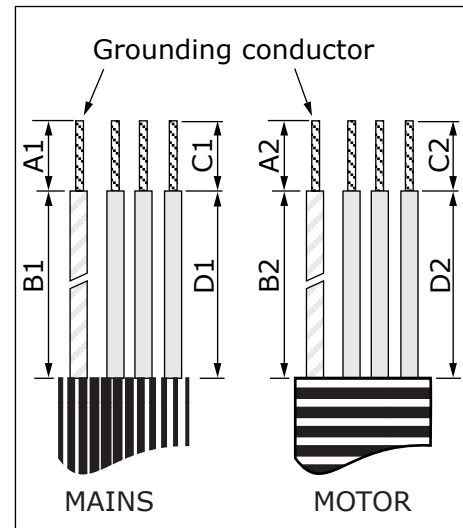

- 2 FR8 only: Open the cover of the AC drive.

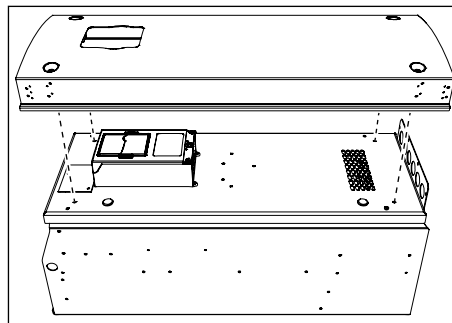

- 3 FR8 only: Open the power unit cover.  
FR9 only: Remove the cable cover.

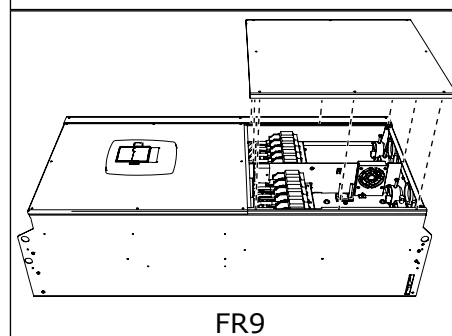
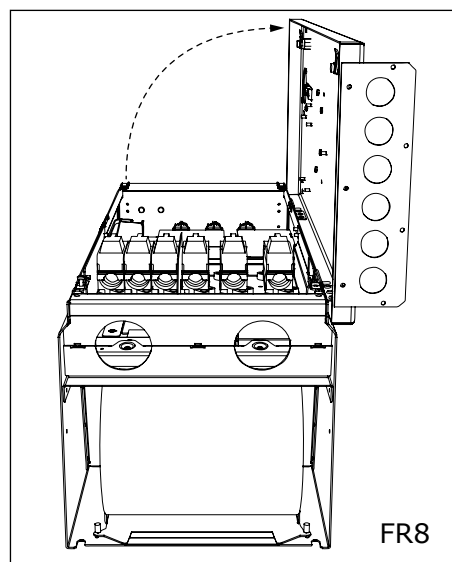

- 4 Remove the cable entry plate.

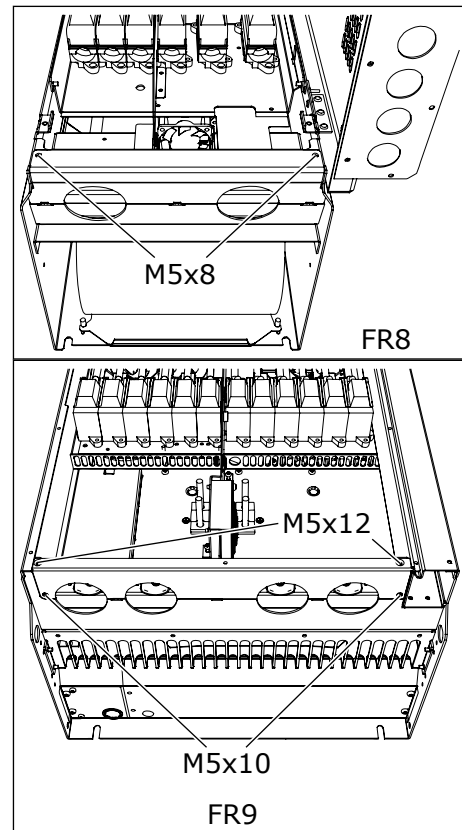

- 5 Find the DC terminals and Brake resistor terminals on top of the AC drive.

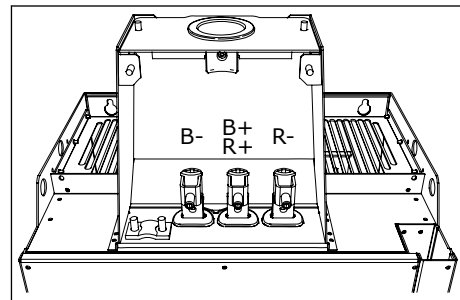

- 6 Cut the grommets open to move the cables through them.
- Do not cut the grommet openings wider than what is necessary for the cables that you use.
  - If the grommets fold in when you put the cable, pull the cable back to make the grommets straight.



**NOTE!**

Use a cable gland as an alternative to the grommet in types where this is necessary.

- 7 Attach the grommet and the cable until the frame of the drive goes into the groove of the grommet.
- With the enclosure class IP54 (UL Type 12), the connection between the grommet and the cable must be tight. Pull the first bit of the cable out of the grommet until it stays straight.
  - If this is not possible, make the connection tight with some insulation tape or a cable tie.

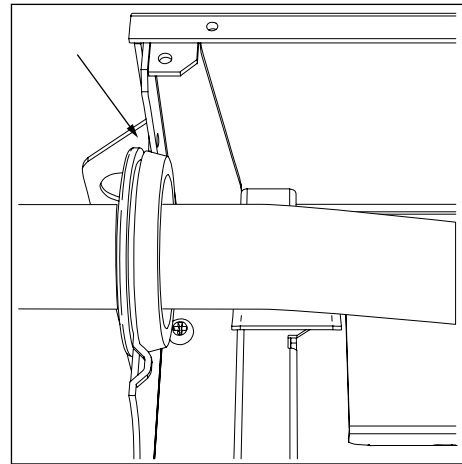

- 8 Connect the cables.
- Connect the phase conductors of the mains cable and of the motor cable into the correct terminals. If you use a brake resistor cable, connect its conductors into the correct terminals.
  - Attach the grounding conductor of each cable to a grounding terminal with a grounding clamp for grounding conductor.
  - See the correct tightening torques in *Table 39*.

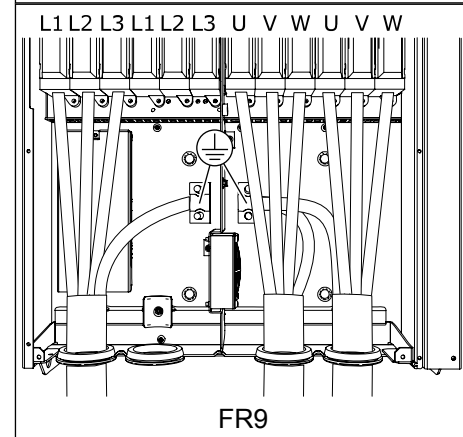
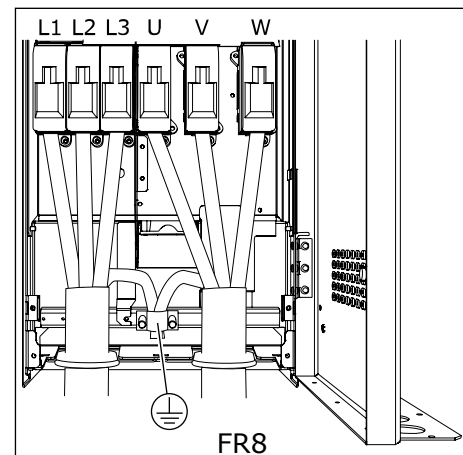

- 9 Expose the shield of all cables to make a 360-degree connection with the grounding clamp for cable shield.

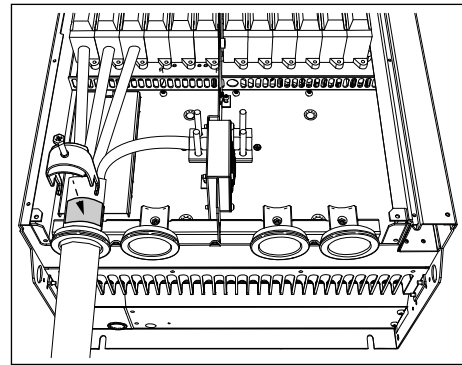

- 10 Attach the cable entry plate, and then the cable cover. For the tightening torques of the screws, see *Table 5 The tightening torques of the cover screws.*

#### Additional tightening torques for FR8:

- motor cable entry plate: 2.4 Nm
- control cable entry plate: 0.8 Nm
- DC cover: 2.4 Nm

Make sure that the control cables or the cables of the AC drive are not caught between the frame and the cable cover.

- 11 For FR8, attach the cover of the drive (unless you want to make the control connections first). For the tightening torques of the screws, see *Table 5 The tightening torques of the cover screws.*

**Table 39: Tightening torques of the terminals**

Enclosure size	Type	Tightening torque: the mains cable and motor cable terminals	
		[Nm]	lb-in.
FR8	0168 2-0205 2 0168 5-0205 5	40	354
FR9	0261 2-0300 2 0261 5-0300 5 0125 6-0208 6	40	354

### 5.7.3 ENCLOSURE SIZES FR10-FR11

For more information on how to install the cables for enclosure sizes FR10 and larger, see VACON® NXP Enclosed Drives User Manual.

## 6 CONTROL UNIT

### 6.1 CONTROL VOLTAGE (+24V/EXT +24V)

It is possible to use the drive with an external power source with these properties: +24 VDC  $\pm 10\%$ , minimum 1000 mA. You can use it to externally power-up the control board, and the basic and expander boards.

Connect the external power source to one of the 2 bidirectional terminals (#6 or #12), see Chapter 6.3 *Installation of option boards*. With this voltage, the control unit stays on and you can set the parameters. The measurements of the main circuit (for example, the DC link voltage, and the unit temperature) are not available when the drive is not connected to mains.



#### NOTE!

If you supply the AC drive with external 24 V DC power, you must use a diode in terminal #6 (or #12) to prevent the current to flow in opposite direction. Put a 1 A fuse in 24 V DC line for each AC drive. The maximum current consumption of each drive is 1 A from the external power supply.

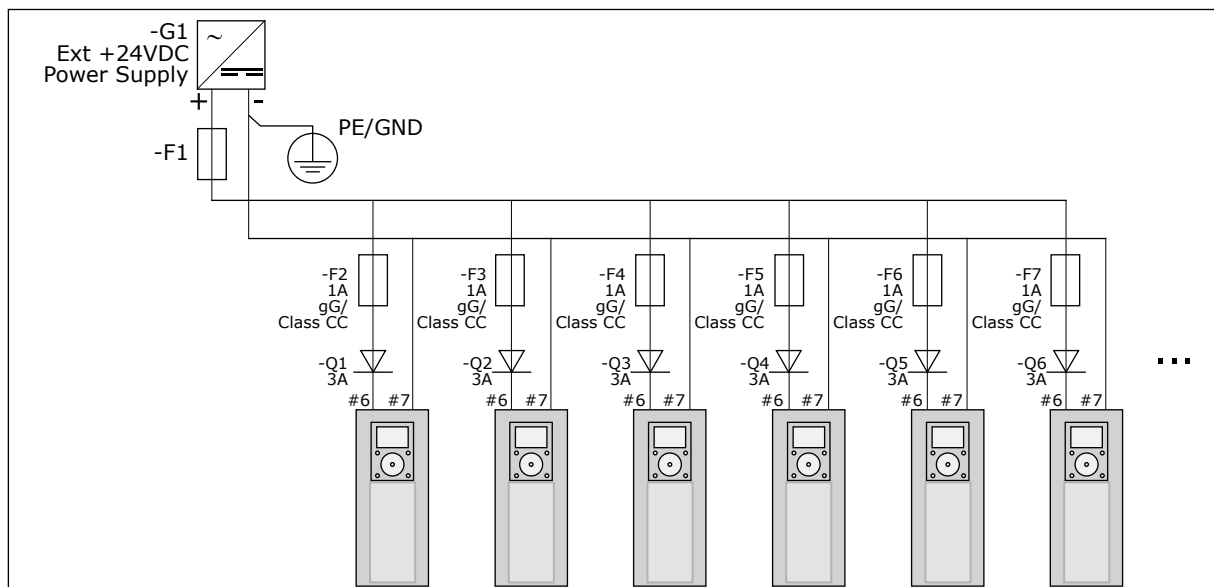

Fig. 22: Parallel connection of 24 V inputs with many AC drives



#### NOTE!

The control unit I/O ground is not isolated from the chassis ground / protective earth. In the installation, take into account the potential differences between the grounding points. We recommend that you use galvanic isolation in the I/O and 24V circuitry.



#### NOTE!

Analogue outputs and inputs at OPTA1 do not work with only +24V supplied to the control unit.



## 6.2 CONTROL UNIT CABLING

The OPTA1 basic board has 20 control terminals, and the relay board has 6 or 7. You can see the standard connections of the control unit and the descriptions of signals in *Fig. 23*.

### 6.2.1 SELECTION OF THE CONTROL CABLES

The control cables must be a minimum of 0.5 mm<sup>2</sup> (20 AWG) screened multicore cables. See more on the cable types in *Table 24 The selection of the correct cable*. The terminal wires must be a maximum of 2.5 mm<sup>2</sup> (14 AWG) for the terminals of the relay board and 1.5 mm<sup>2</sup> (16 AWG) for other terminals.

**Table 40: The tightening torques of the control cables**

The terminal	The terminal screw	The tightening torque	
		Nm	lb-in.
Relay and thermistor terminals	M3	0.5	4.5
Other terminals	M2.6	0.2	1.8

### 6.2.2 CONTROL TERMINALS ON OPTA1

Here you see the basic description of the terminals of the I/O board and the relay board. For more information, see *6.2.2.2 Jumper selections on the OPTA1 basic board*. For more information on control terminals, see VACON® All in One Application manual.

		Standard I/O board		
		Terminal	Signal	Description
	1	+10V <sub>ref</sub>	Reference voltage	Maximum current 10 mA
	2	AI1+	Analogue input, voltage or current	Selection V/mA with jumper block X1 (*) 0...+10 V (R <sub>i</sub> = 200 kΩ) (-10V...+10V Joystick ctrl, sel. with jumper) 0-20 mA (R <sub>i</sub> = 250 Ω)
	3	GND/AI1-	Analogue input common	Differential input if not connected to ground Allows ±20 V common mode voltage to GND
	4	AI2+	Analogue input, voltage or current	Selection V/mA with jumper block X1 (*) 0...+10 V (R <sub>i</sub> = 200 kΩ) (-10V...+10V Joystick ctrl, sel. with jumper) 0-20 mA (R <sub>i</sub> = 250 Ω)
	5	GND/AI2-	Analogue input common	Differential input if not connected to ground Allows ±20 V common mode voltage to GND
	6	+24V	24 V aux. voltage	±15%, max. 250 mA (all boards total) 150 mA (from single board) Can also be used as external power backup for the control unit (and fieldbus)
	7	GND	I/O ground	Ground for reference and controls
	8	DIN1	Digital input 1	R <sub>i</sub> = min. 5 kΩ 18-30 V = 1
	9	DIN2	Digital input 2	
	10	DIN3	Digital input 3	
	11	CMA	Common A for DIN1—DIN3	Digital inputs can be disconnected from ground (†)
	12	+24V	Control voltage output	Same as terminal #6
	13	GND	I/O ground	Same as terminal #7
	14	DIN4	Digital input 4	R <sub>i</sub> = min. 5 kΩ 18-30 V = 1
	15	DIN5	Digital input 5	
	16	DIN6	Digital input 6	
	17	CMB	Common B for DIN4-DIN6	Must be connected to GND or 24 V of I/O term. or to ext.24 V or GND Selection with jumper block X3 (*)
	18	AO1+	Analogue signal (+output)	Output signal range: Current 0(4)-20 mA, R <sub>L</sub> max 500 Ω or Voltage 0-10 V, R <sub>L</sub> >1kΩ Selection with jumper block X6 (*)
	19	AO1-	Analogue output common	
	20	DO1	Open collector output	Maximum U <sub>in</sub> = 48 VDC Maximum current = 50 mA

Fig. 23: The control terminal signals in OPTA1

\*) See Fig. 26 Jumper blocks on OPTA1.

Parameter references for I/O on keypad and NCDrive are: An.IN:A.1, An.IN:A.2, DigIN:A.1, DigIN:A.2, DigIN:A.3, DigIN:A.4, DigIN:A.5, DigIN:A.6, AnOUT:A.1 and DigOUT:A.1.

To use the control voltage output +24V/EXT+24V:

- you can wire the +24V control voltage to digital inputs through an external switch.
- you can use the control voltage to power up external equipment, such as encoders and auxiliary relays.

Note that the specified total load on all available +24V/EXT+24V output terminals must not exceed 250mA. The maximum load on the +24V/EXT+24V output per board is 150mA.

If there is a +24V/EXT+24V output on the board, it is locally short-circuit protected. If one of the +24V/EXT+24V outputs short-circuits, the others remain powered because of the local protection.

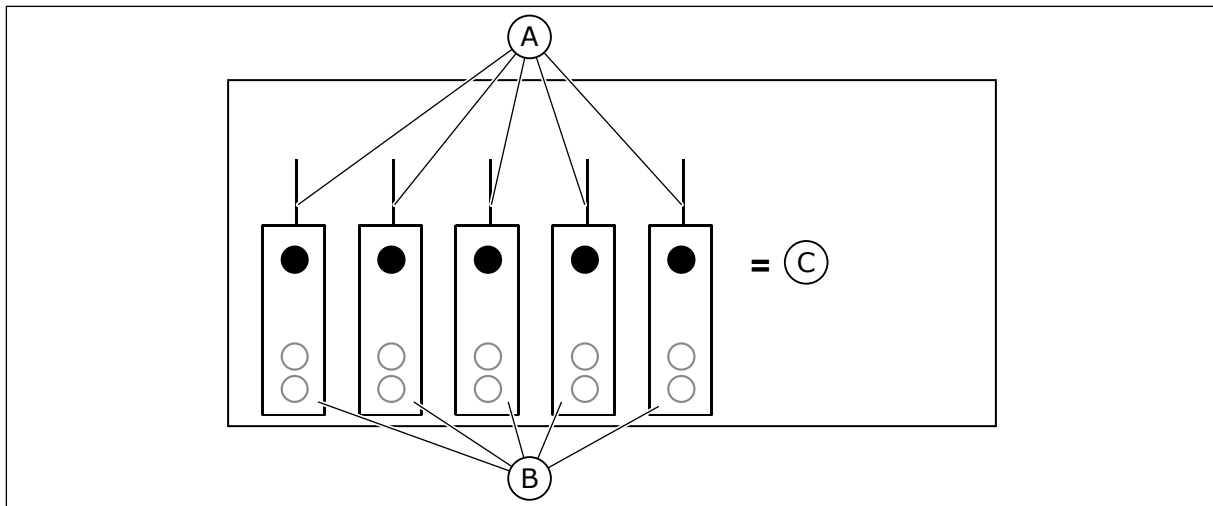

Fig. 24: Maximum loads on +24V/EXT+24V output

A. Max. 150 mA  
B. +24 V out

C. Max. 250 mA

### 6.2.2.1 Digital input signal inversions

The active signal level is different when the common inputs CMA and CMB (terminals 11 and 17) are connected to +24 V or to ground (0 V). See Fig. 25.

The 24 V control voltage and the ground for the digital inputs and the common inputs (CMA, CMB) can be internal or external.

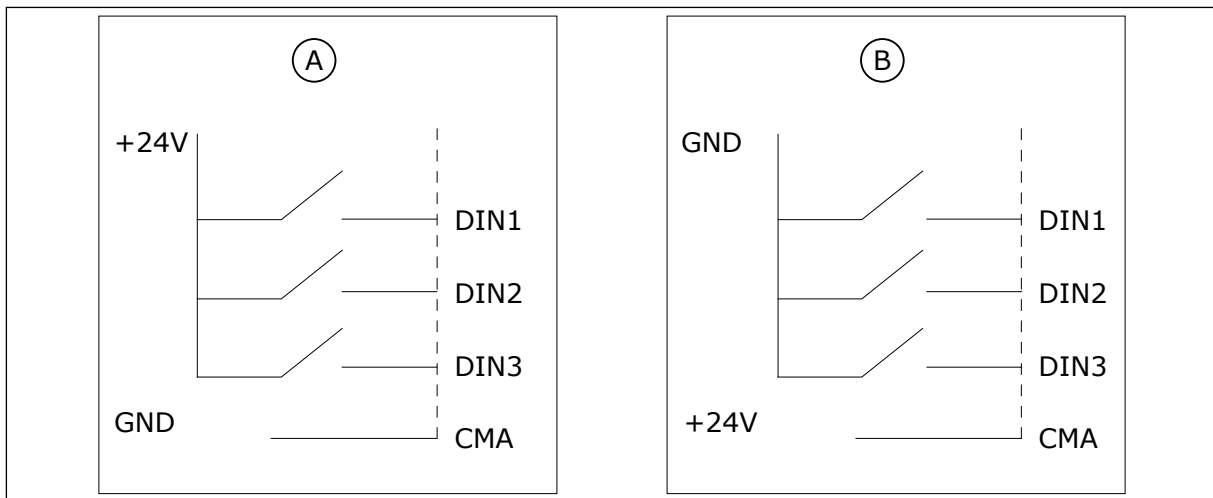

Fig. 25: The Positive/Negative logic

A. Positive logic (+24 V is the active signal) = the input is active when the switch is closed.

B. Negative logic (0 V is the active signal) = the input is active when the switch is closed. You must set the jumper X3 to the position 'CMA/CMB isolated from ground'.

### 6.2.2.2 Jumper selections on the OPTA1 basic board

You can change the functions of the AC drive to make them better agree with your requirements. To do this, change some positions for the jumpers on the OPTA1 board. The positions of the jumpers set the signal type of analogue and digital inputs.

On the A1 basic board, there are 4 jumper blocks: X1, X2, X3 and X6. Each jumper block contains 8 pins and 2 jumpers. See the possible jumper selections in Fig. 26.

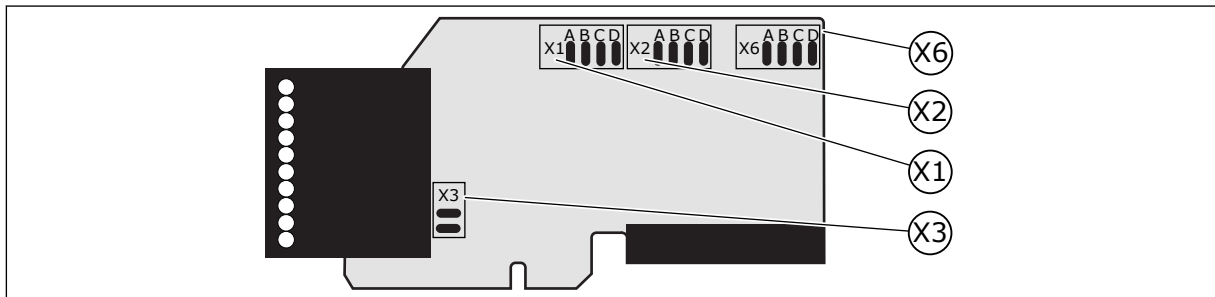

Fig. 26: Jumper blocks on OPTA1

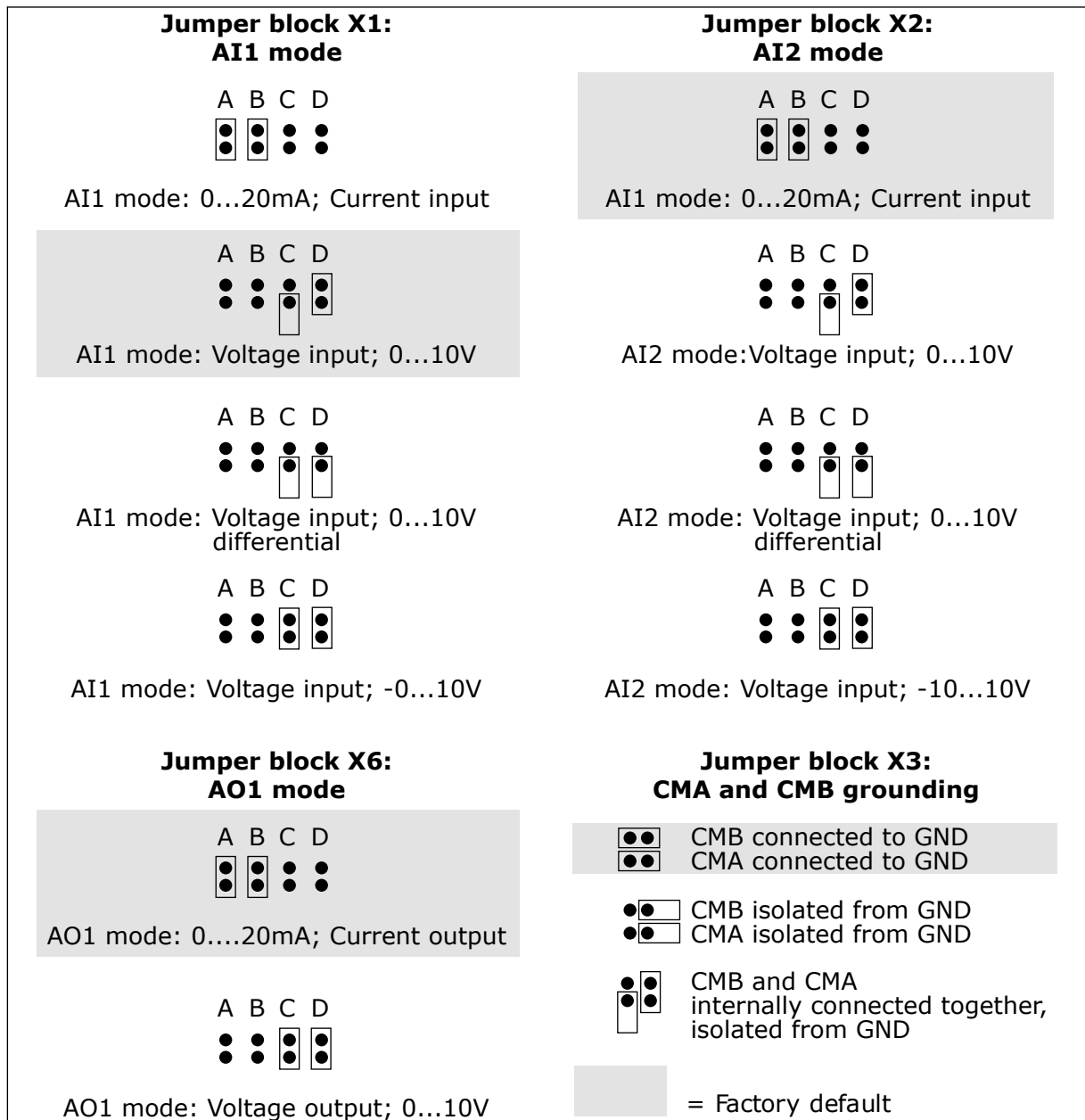

Fig. 27: Jumper selections for OPTA1

**NOTE!**

If you change the AI/AO signal contents, also change the related board parameter in menu M7.

### 6.2.3 CONTROL TERMINALS ON OPTA2 AND OPTA3





OPTA2			
21	RO1/1	 Relay output 1 DigOUT:B.1 *)	Switching capacity • 24 VDC/8 A • 250 VAC/8 A • 125 VDC/0.4 A Minimum switching load • 5 V/10 mA
22	RO1/2		
23	RO1/3		
24	RO2/1	 Relay output 2 DigOUT:B.2 *)	Switching capacity • 24 VDC/8 A • 250 VAC/8 A • 125 VDC/0.4 A Minimum switching load • 5 V/10 mA
25	RO2/2		
26	RO2/3		
OPTA3			
21	RO1/1	 Relay output 1 DigOUT:B.1 *)	Switching capacity • 24 VDC/8 A • 250 VAC/8 A • 125 VDC/0.4 A Minimum switching load • 5 V/10 mA
22	RO1/2		
23	RO1/3		
25	RO2/1	 Relay output 2 DigOUT:B.2 *)	Switching capacity • 24 VDC/8 A • 250 VAC/8 A • 125 VDC/0.4 A Minimum switching load • 5 V/10 mA
26	RO2/2		
28	TI1+		
29	TI1-	Thermistor input DigIN:B.1 *)	

Fig. 28: The control terminal signals on relay boards OPTA2 and OPTA3

\*) Parameter reference on keypad and NCDrive.

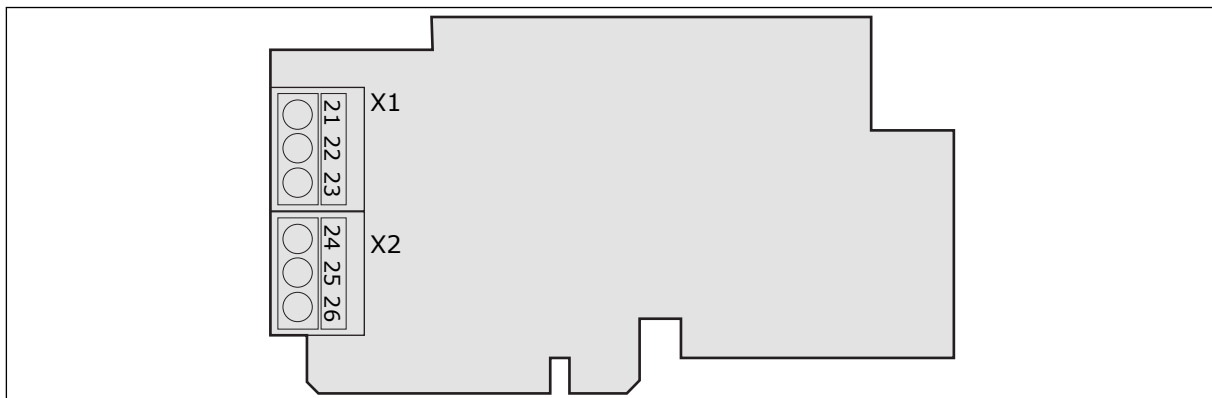

Fig. 29: OPTA2

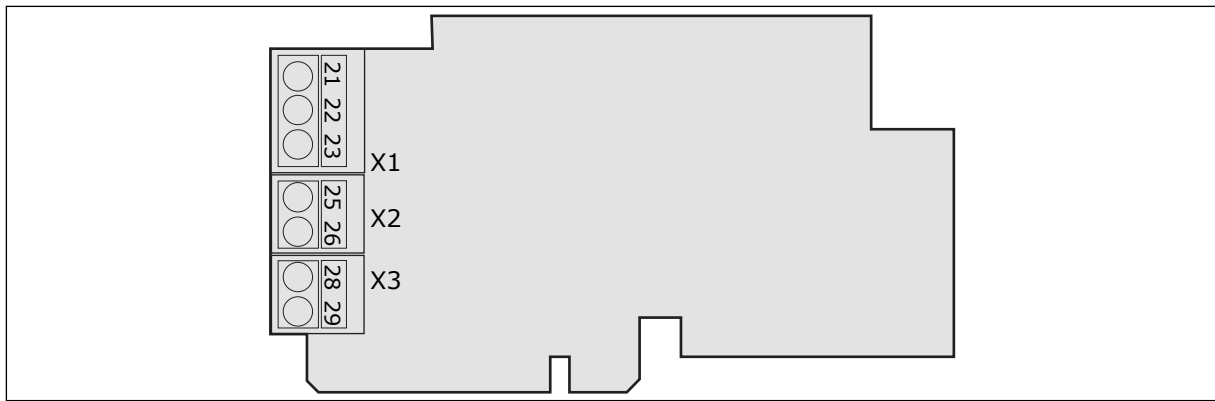

Fig. 30: OPTA3

### 6.3 INSTALLATION OF OPTION BOARDS

For information on how to install the option boards, see the option board manual or VACON® NX I/O Boards User Manual.

### 6.4 GALVANIC ISOLATION BARRIERS

The control connections are isolated from mains. The GND terminals are permanently connected to I/O ground. See Fig. 31 The galvanic isolation barriers.

The digital inputs on the I/O board are galvanically isolated from the I/O ground. The relay outputs are also double-isolated from each other at 300VAC (EN-50178).

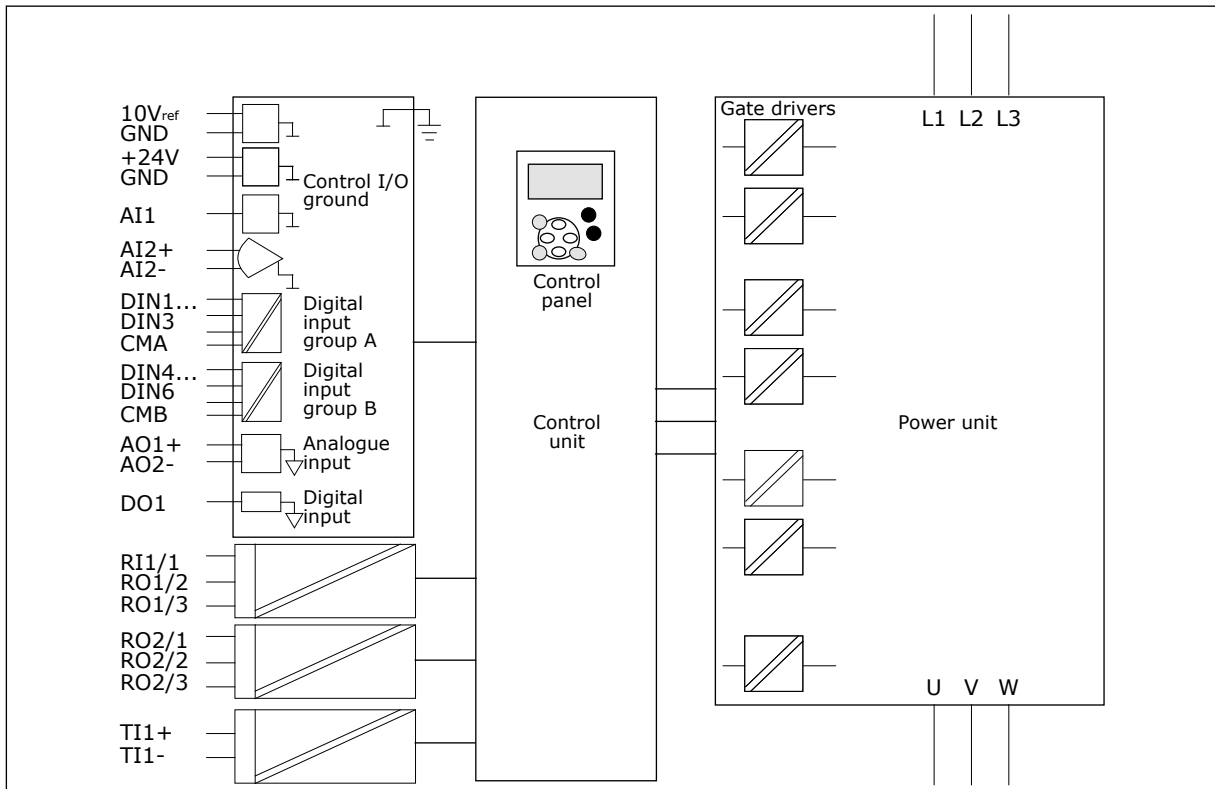

Fig. 31: The galvanic isolation barriers

## 7 CONTROL PANEL

The control panel is the interface between the AC drive and the user. With the control panel, you can control the speed of a motor and monitor the status of the AC drive. You can also set the parameters of the AC drive.

You can remove the control panel from the AC drive. The control panel is isolated from the input line potential.

### 7.1 CONTROL KEYPAD

The VACON® control keypad has 9 buttons with which you can control the AC drive (and motor), set parameters and monitor values.

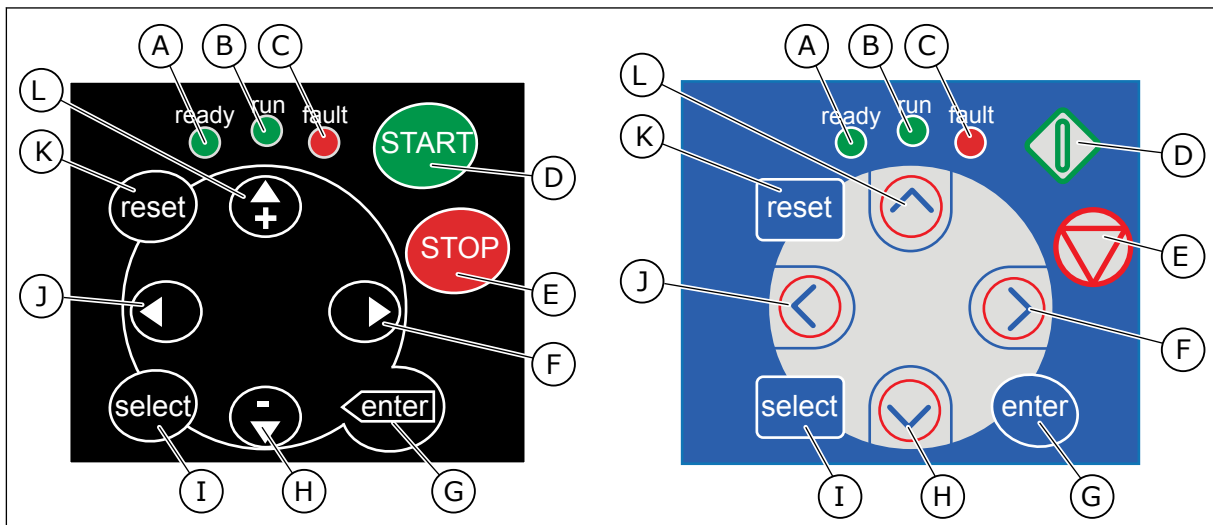

Fig. 32: Keypad buttons, left: NX5, right: NXP

- A. The LED is on when the AC power is connected to the drive and no faults are active. At the same time, the drive status indication shows READY.
- B. The LED is on when the drive operates. The LED blinks when the STOP button is pushed and the drive ramps down.
- C. The LED blinks when the AC drive is stopped because of dangerous conditions (Fault Trip). See Chapter 7.7 *Using the Active faults menu (M4)*.
- D. The Start button. When the keypad is the active control place, this button starts the motor. See Chapter 7.6.1 *Control place*.
- E. The Stop button. The button stops the motor (unless the stop is disabled by the parameter R3.4/R3.6). See Chapter 7.6.1 *Control place*.
- F. The Menu button Right. Use it to move forward in the menu, move the cursor right (in the parameter menu) and to go to the edit mode.
- G. The Enter button. Use it to accept a selection, reset the fault history (push for 2-3 seconds).
- H. The Browser button Down. Use it to scroll the main menu and the pages of different submenus and to decrease a value.
- I. The Select button. Use it to move between 2 last displays, for example, to see how new value changes some other value.
- J. The Menu button Left. Use it to move back in the menu, move the cursor left (in the Parameter menu).
- K. The Reset button. Use it to reset a fault.

- L. The Browser button Up. Use it to scroll the main menu and the pages of different submenus and to increase a value.

## 7.2 DISPLAY

The drive status indicators (A-G) gives you information about the status of the motor and the AC drive.

The control place indications (H, I, J) show the selection of the control place. The control place tells from where the START/STOP commands are given and reference values are changed. To make this selection, go to the Keypad control menu (M3) (see Chapter 7.6 *Using the Keypad control menu (M3)*).

The three text lines (K, L, M) give information about your location in the menu structure and the operation of the drive.

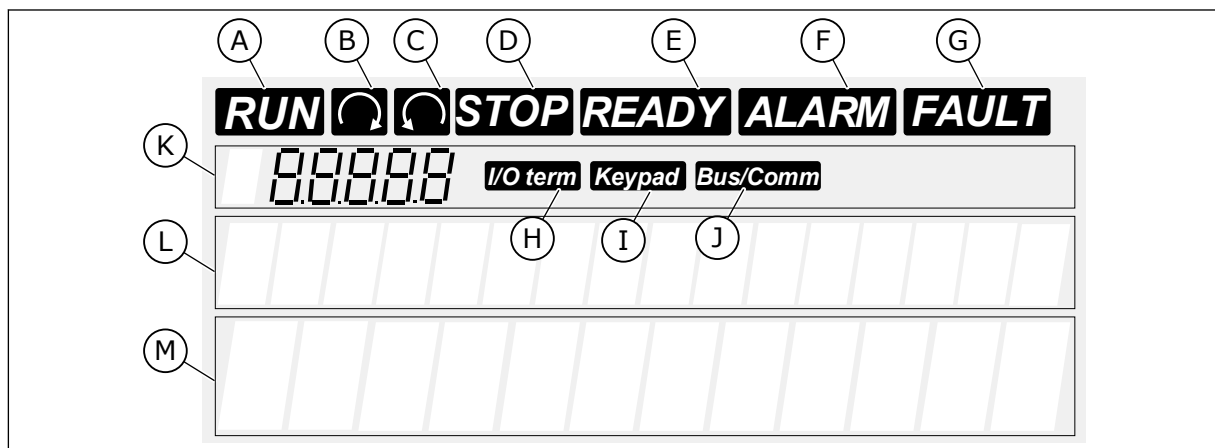

Fig. 33: Display indications

- A. The motor is in RUN state. The indication starts to blink when a stop command is given and blinks while the speed continues to decrease.
- B. The direction of motor rotation is forward.
- C. The direction of motor rotation is reverse.
- D. The drive does not operate.
- E. The AC power is on.
- F. An alarm is given.
- G. A fault is given and the AC drive is stopped.
- H. The I/O terminals is the active control place.
- I. The Control keypad is the active control place.
- J. The fieldbus is the active control place.
- K. The location indication. The line shows the symbol and number of the menu, parameter and so on. For example, M2 = Menu 2 (Parameters) or P2.1.3 = Acceleration time.
- L. The description line. The line shows the description of the menu, value or fault.
- M. The value line. The line shows the numerical and text values of references, parameters and so on. It also shows the number of submenus that are available in each menu.



### 7.3 NAVIGATION ON THE CONTROL PANEL

The data of the AC drive is in menus and submenus. To move between the menus, use the Browser buttons Up and Down in the keypad. To go into a group or an item, push the Menu button Right. To go back to the level where you were before, push the Menu button Left. On the display, you see your current location in the menu, for example S6.3.2. You also see the name of the group or item in your current location.

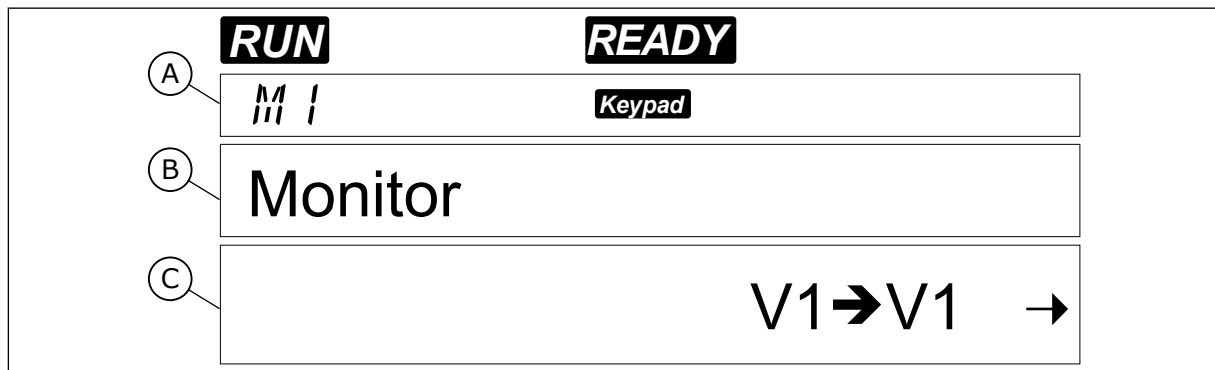

Fig. 34: The navigation items on the control panel

- A. The location on the menu
- B. The description (name of the page)
- C. The number of items that are available or the item value.

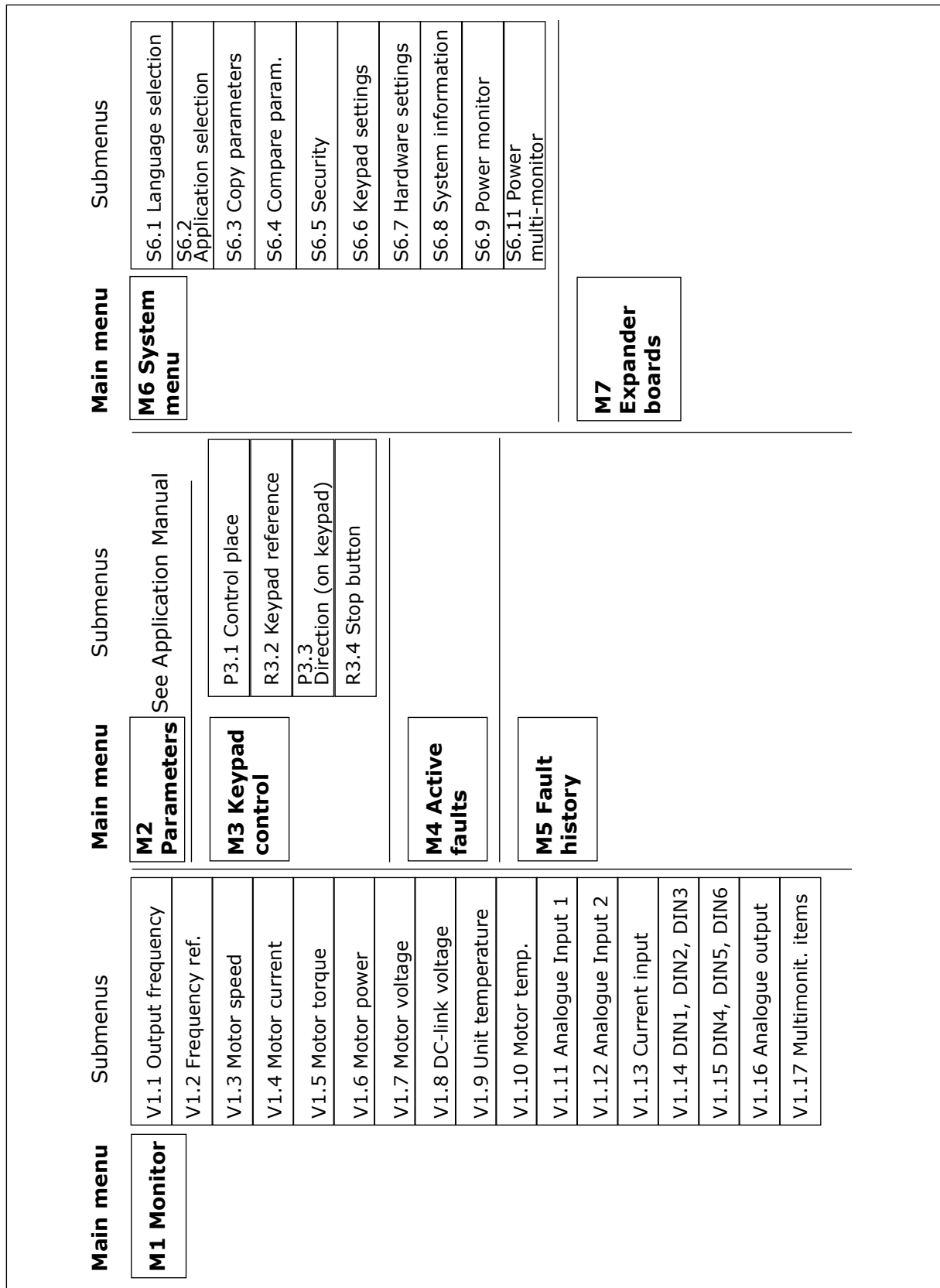

Fig. 35: The basic menu structure of the AC drive

## 7.4 USING THE MONITORING MENU (M1)

You can monitor the actual values of the parameters and signals. You cannot change the values in the Monitoring menu. To change the values of parameters, see Chapter 7.5 *Using the Parameter menu (M2)*.

The monitored signals have the indication V#.#. The values update each 0.3 seconds.

**Table 41: Monitored signals**

Index	Monitoring value	Unit	ID	Description
V1.1	Output frequency	Hz	1	The output frequency to the motor
V1.2	Frequency reference	Hz	25	The frequency reference to motor control
V1.3	Motor speed	rpm	2	The actual speed of the motor in rpm
V1.4	Motor current	A	3	Measured motor current
V1.5	Motor torque	%	4	The calculated shaft torque
V1.6	Motor power	%	5	The calculated motor shaft power in percentage
V1.7	Motor voltage	V	6	The output voltage to the motor
V1.8	DC link voltage	V	7	The measured voltage in the DC-link of the drive
V1.9	Unit temperature	°C	8	The heat sink temperature in Celsius or Fahrenheit
V1.10	Motor temperature	%	9	The calculated motor temperature in percentage of the nominal temperature. See VACON® All in One Application Manual.
V1.11	Analogue input 1	V/mA	13	A11 *
V1.12	Analogue input 2	V/mA	14	A12 *
V1.13	DIN 1, 2, 3		15	Shows the status of the digital inputs 1-3
V1.14	DIN 4, 5, 6		16	Shows the status of the digital inputs 4-6
V1.15	DO1, RO1, RO2		17	Shows the status of the digital and relay outputs 1-3
V1.16	Analogue lout	mA	26	A01
V1.17	Multimonitoring items			Displays 3 monitoring values from which you can select. See Chapter 7.9.5.4 <i>Multimonitoring items (P6.5.4)</i> .

\* If the AC drive only has +24V supply (for control board power-up), this value is not reliable.

See VACON® All in One Application Manual for more monitoring values.

- 1 To find the Monitoring menu, scroll down in the Main menu until the location indication M1 shows on the first line of the display.



- 2 To go to the Monitoring menu from the Main menu, push the Menu button Right.

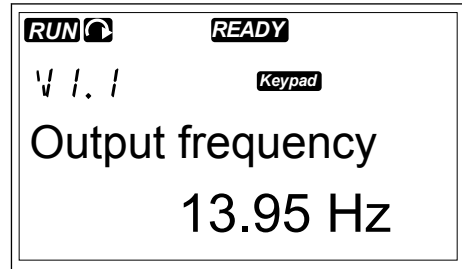

- 3 To scroll through the menu, push the Browser buttons Up and Down.

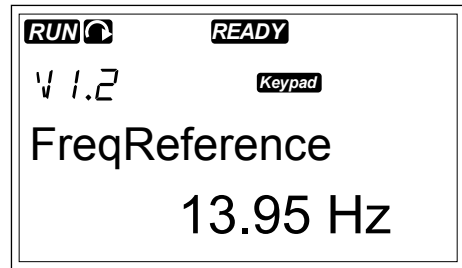

## 7.5 USING THE PARAMETER MENU (M2)

### FINDING THE PARAMETER

- 1 To find the Parameter menu, scroll down in the Main menu until the location indication M2 shows on the first line of the display.

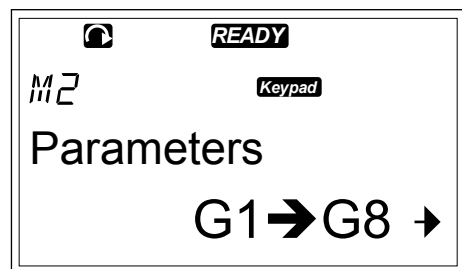

- 2 Push the Menu button Right to move into the Parameter Group Menu (G#).

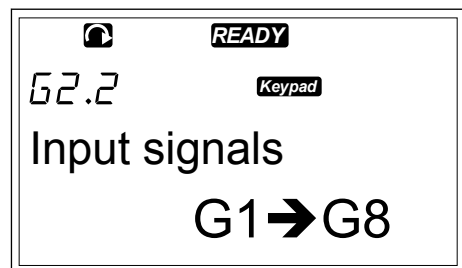

- To find the parameter group, use the Browser buttons Up and Down.

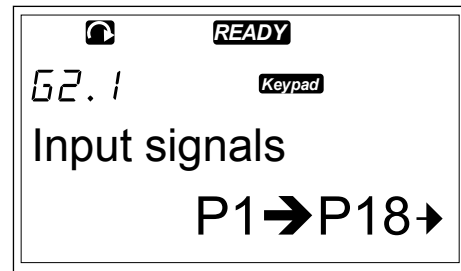

- Use the Browser buttons Up and Down to find the parameter (P#) you want to edit. When you are in the last parameter of a parameter group, push the Browser button Up to move directly to the first parameter of that group.

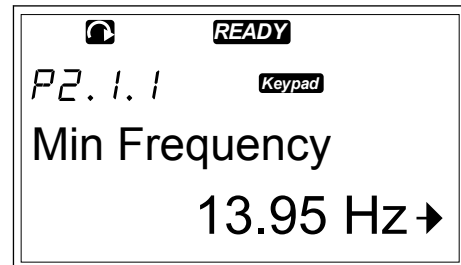

### EDITING THE TEXT VALUES

- Find the parameter with the Browser and Menu buttons.

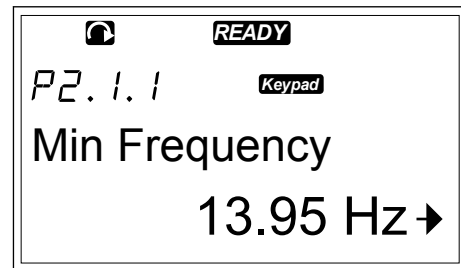

- To go to the Edit mode, push the Menu button Right. The parameter value starts to blink.

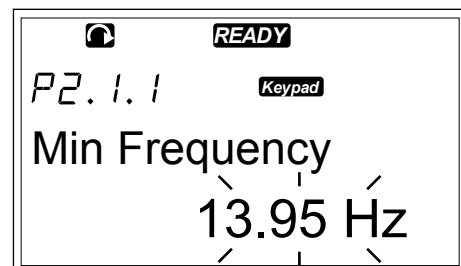

- Set the new value with the Browser buttons Up and Down.

- To accept the change, push the Enter button. The value stops to blink and the new value shows in the value field.

**NOTE!**

The value does not change if you do not push the Enter button.

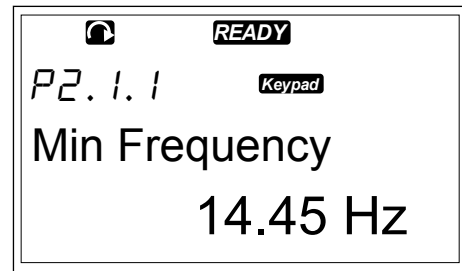
**EDITING THE NUMERICAL VALUES**

- Find the parameter with the Browser and Menu buttons.

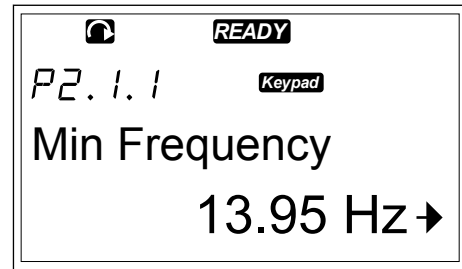

- To go to the Edit mode, push the Menu button Right. The parameter value starts to blink.

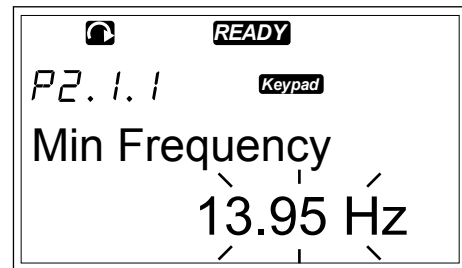

- Push the Menu button Right. You can now edit the value digit by digit.
- To accept the change, push the Enter button. The value stops to blink and the new value shows in the value field.

**NOTE!**

The value does not change if you do not push the Enter button.

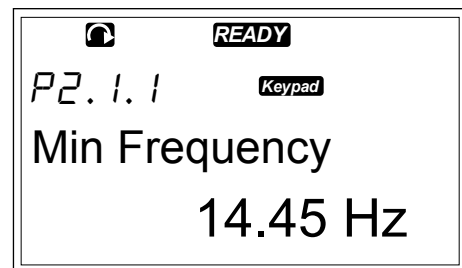

When the drive is in RUN state, many parameters are locked, and you cannot edit them. If you try to change the value of such a parameter, the text \*Locked\* shows on the display. You must stop the AC drive to edit these parameters. To lock parameter values, use the function in menu M6 (See Chapter 7.9.5.2 *Parameter lock (P6.5.2)*).

The basic application package "All in One+" includes 7 applications with different sets of parameters. For more information, see VACON® All in One Application Manual.

## 7.6 USING THE KEYPAD CONTROL MENU (M3)

In the Keypad Control Menu, you can select the control place, edit the frequency reference and change the direction of the motor.

1 To find the Keypad control menu, scroll down in the Main menu until the location indication M3 shows on the first line of the display.

2 To go to the Keypad control menu from the Main menu, push the Menu button Right.

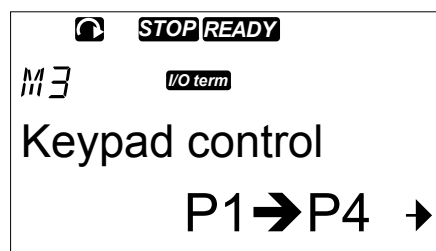

**Table 42: Keypad control parameters, M3**

Index	Parameter	Min	Max	Unit	Default	Cust	ID	Description
P3.1	Control place	1	3		1		125	1 = I/O terminal 2 = Keypad 3 = Fieldbus
R3.2	Keypad reference	P2.1.1	P2.1.2	Hz	0.00			
P3.3	Direction (on keypad)	0	1		0		123	0 = Forward 1 = Reverse
R3.4	Stop button	0	1		1		114	0 = Limited function of Stop button 1 = Stop button always enabled

### 7.6.1 CONTROL PLACE

You can use 3 control places to control the AC drive. For each control place, a different symbol shows on the display:

**Table 43: The symbols for the control place**

The control place	The symbol
I/O terminals	<b>I/O term</b>
Keypad (panel)	<b>Keypad</b>
Fieldbus	<b>Bus/Comm</b>

## CHANGING THE CONTROL PLACE

- 1 In the Keypad control menu (M3), find the Control Place with Menu buttons Up and Down.



- 2 To go to the edit mode, push the Menu button Right.

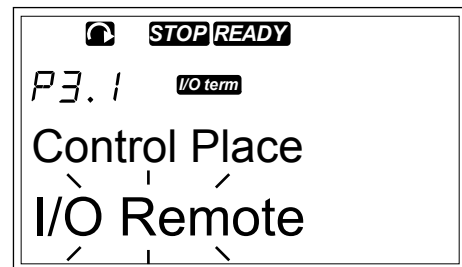

- 3 To scroll through the options, push the Browser buttons Up and Down.

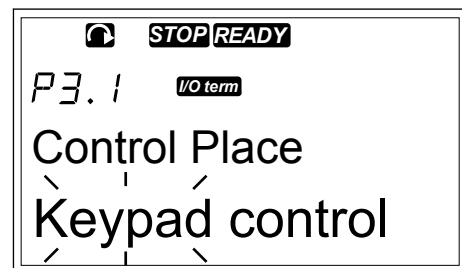

- 4 To select the control place, push the Enter button.



### 7.6.2 THE KEYPAD REFERENCE SUBMENU (P3.2)

The keypad reference submenu (P3.2) shows the frequency reference. In this submenu you can also edit the frequency reference. The value changes on the control panel. To make the motor speed to agree with the value on the control panel, select the keypad as the control place.

#### EDITING THE FREQUENCY REFERENCE

- 1 In the Keypad control menu (M3), find the Keypad reference with Menu buttons Up and Down.
- 2 To go to the edit mode, push the Menu button Right. The frequency reference value starts to blink.
- 3 Set the new value with the Browser buttons.



### 7.6.3 CHANGING THE ROTATION DIRECTION

The keypad direction submenu shows the rotation direction of the motor. In this submenu, you can also change the rotation direction. To make the motor to agree with the set rotation direction, select the keypad as the control place.

- 1 In the Keypad control menu (M3), find the Keypad direction with the Menu buttons Up and Down.
- 2 To go to the edit mode, push the Menu button Right.
- 3 Select the direction with Menu buttons Up and Down.

**NOTE!**

For more information on how to control the motor with the keypad, see Chapters 7.1 *Control keypad* and 8.2 *Commissioning of the drive*.

### 7.6.4 DISABLING THE STOP MOTOR FUNCTION

As a default, the motor stops when you push the STOP button no matter what is the control place.

- 1 In the Keypad control menu (M3), find the page 3.4. Stop button with the Browser buttons.
- 2 To go to the edit mode, push the Menu button Right.
- 3 To select Yes or No, use the Browser buttons.
- 4 Accept the selection with the Enter button.

When the Stop motor function is not active, the STOP button stops the motor only when the keypad is the control place.

### 7.6.5 SPECIAL FUNCTIONS IN THE KEYPAD CONTROL MENU

There are some special functions that you can do in menu M3.

**NOTE!**

If you are in other menu than M3, the special functions are not available. In other menu than M3, when the keypad is not the active control place and you push the start button, you get an error message Keypad Control NOT ACTIVE.

### SELECTING THE KEYPAD AS THE CONTROL PLACE

- 1 You have 2 options:
  - Keep the START button pushed down for 3 seconds when the motor is in RUN state.
  - Keep the STOP button pushed down for 3 seconds when the motor is stopped.

The keypad is selected as the control place and the current frequency reference and direction is copied to the keypad.

## COPYING THE FREQUENCY REFERENCE SET FROM I/O OR FIELDBUS TO THE CONTROL PANEL

- 1 Keep the Enter button pushed down for 3 seconds.

### 7.7 USING THE ACTIVE FAULTS MENU (M4)

The Active faults menu shows a list of active faults. When there are no active faults, the menu is empty.

- 1 To find the Active faults menu, scroll down in the Main menu until the location indication M4 shows on the first line of the display.

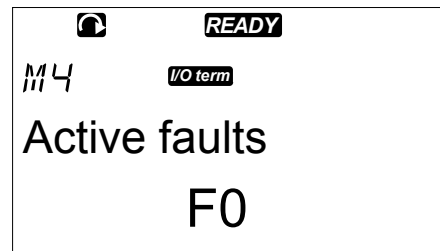

- 2 To go to the Active faults menu from the Main menu, push the Menu button Right.

If there is a Fault in the display, these symbols show:

- A) Fault symbol
- B) Fault type symbol (see *Table 62 Fault types*)

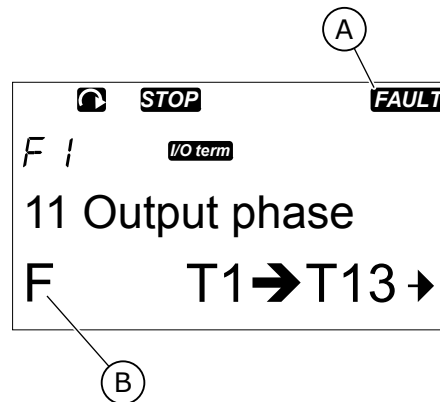

For more information on the fault types and how to reset faults, see Chapter 10 *Fault tracing*. For the fault codes, possible causes and information on how to correct the fault, see Chapter 10.2 *Fault codes*.

#### 7.7.1 THE FAULT TIME DATA RECORD

This menu shows some important data that was valid at the time of the fault. This helps you to find the cause of the fault.

The data available are:

**Table 44: The fault time recorded data**

	Description	Type
T.1	Counted operation days	d
T.2	Counted operation hours	hh:mm:ss (d)
T.3	Output frequency	Hz (hh:mm:ss)
T.4	Motor current	A
T.5	Motor voltage	V
T.6	Motor power	%
T.7	Motor torque	%
T.8	DC voltage	V
T.9	Unit temperature	°C
T.10	Run status	
T.11	Direction	
T.12	Warnings	
T.13	0-speed*	
T.14	Subcode	
T.15	Module	
T.16	Submodule	

\* Tells if the drive was at zero speed (< 0.01 Hz) when the fault showed.

### THE REAL TIME RECORD

If real time is set on the AC drive, the data items T1 and T2 show as follows:

	Description	Type
T.1	Counted operation days	yyyy-mm-dd
T.2	Counted operation hours	hh:mm:ss,sss

## EXAMINING THE FAULT TIME DATA RECORD

- 1 Find the fault in Active faults menu or Fault history menu.

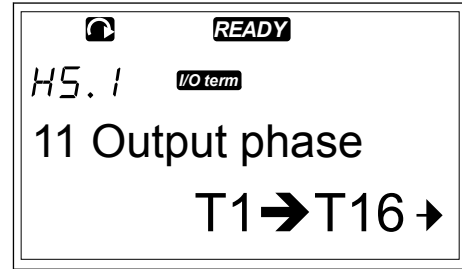

- 2 Push the Menu button Right.

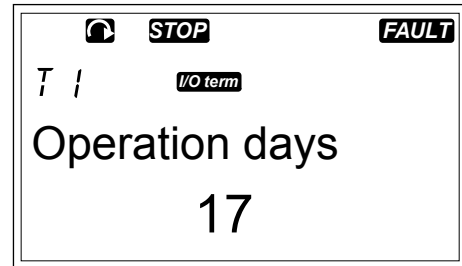

- 3 Scroll the data T.1-T.16 with the Browser buttons.

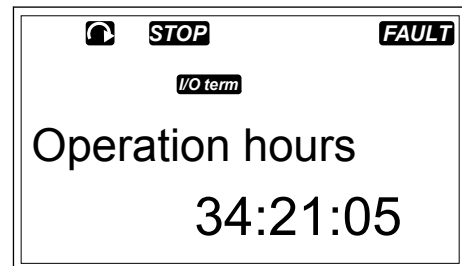

## 7.8 USING THE FAULT HISTORY MENU (M5)

There is a maximum number of 30 faults in the Fault history. You can also see the information on each fault in the Fault time data record (see Chapter 7.7.1 *The fault time data record*).

The value line of the main page (H1->H#) shows the number of faults in the fault history. The location indication tells in which order the faults have shown. The newest fault has the indication H5.1, the second newest H5.2, and so on. If there are 30 faults in the history, the next fault that shows removes the oldest one (H5.30) from the history.

See the different fault codes in Chapter 10.2 *Fault codes*.

1 To find the Fault history menu, scroll down in the Main menu until the location indication M5 shows on the first line of the display.

2 To go to the Fault history menu from the Main menu, push the Menu button Right.

### RESETTING THE FAULT HISTORY MENU

- 1 In the Fault history menu, push the Enter button for 3 seconds.  
The symbol H# changes to 0.

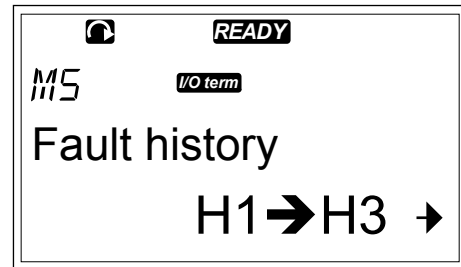

### 7.9 USING THE SYSTEM MENU (M6)

The System menu includes the general settings of the AC drive. These are, for example, application selection, parameter sets and information about the hardware and software. The number of submenus and subpages shows as the symbol S# (or P#) on the value line.

1 To find the System menu, scroll down in the Main menu until the location indication M6 shows on the first line of the display.

2 To go to the System menu from the Main menu, push the Menu button Right.

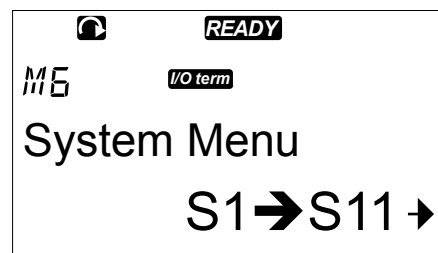

**Table 45: System menu functions**

Code	Function	Min	Max	Unit	Default	Cust	Description
S6.1	Language selection				English		The selection is different in all the language packages
S6.2	Application selection				Basic application		Basic application Standard application Local/Remote control appl. Multi-Step application PID Control application Multi-Purpose Control appl. Pump and Fan Control appl.
S6.3	Copy parameters						
S6.3.1	Parameter sets						Store set 1 Load set 1 Store set 2 Load set 2 Load factory defaults
S6.3.2	Load up to keypad						All parameters
S6.3.3	Load down from keypad						All parameters All but motor parameters Application parameters
P6.3.4	Parameter backup				Yes		Yes No
S6.4	Compare parameters						
S6.4.1	Set1				Not used		
S6.4.2	Set2				Not used		
S6.4.3	Factory settings						
S6.4.4	Keypad set						
S6.5	Security						
S6.5.1	Password				Not used		0 = Not use
P6.5.2	Parameter lock				Change Enabled		Change Enabled Change Disabled

**Table 45: System menu functions**

Code	Function	Min	Max	Unit	Default	Cust	Description
S6.5.3	Start-up wizard						No Yes
S6.5.4	Multimonitoring items						Change Enabled Change Disabled
S6.6	Keypad settings						
P6.6.1	Default page						
P6.6.2	Default page/ Operating menu						
P6.6.3	Timeout time	0	65535	s	30		
P6.6.4	Contrast	0	31		18		
P6.6.5	Backlight time	Always	65535	min	10		
S6.7	Hardware settings						
P6.7.1	Internal brake resistor				Connec- ted		Not connected Connected
P6.7.2	Fan control				Continu- ous		Continuous Temperature First start Calc temp
P6.7.3	HMI acknowledg. timeout	200	5000	ms	200		
P6.7.4	HMI number of retries	1	10		5		
P6.7.5	Sine filter				Connec- ted		Not connected Connected
S6.8	System informa- tion						
S6.8.1	Total counters						
C6.8.1.1	MWh counter			kWh			
C6.8.1.2	Power On day counte						

**Table 45: System menu functions**

Code	Function	Min	Max	Unit	Default	Cust	Description
C6.8.1.3	Power On hours counter			hh:mm:ss			
S6.8.2	Trip counters						
T6.8.2.1	MWh counter			kWh			
T6.8.2.2	Clear MWh trip counter						
T6.8.2.3	Operating days trip counter						
T6.8.2.4	Operating hours trip counter			hh:mm:ss			
T6.8.2.5	Clear operating time counter						
S6.8.3	Software info						
S6.8.3.1	Software package						
S6.8.3.2	System software version						
S6.8.3.3	Firmware interface						
S6.8.3.4	System load						
S6.8.4	Applications						
S6.8.4.#	Name of application						
D6.8.4.#.1	Application ID						
D6.8.4.#.2	Applications: Version						
D6.8.4.#.3	Applications: Firmware interface						
S6.8.5	Hardware						
I6.8.5.1	Info: Power unit type code						
I6.8.5.2	Info: Unit voltage			V			
I6.8.5.3	Info: Brake chopper						



**Table 45: System menu functions**

Code	Function	Min	Max	Unit	Default	Cust	Description
I6.8.5.4	Info: Brake resistor						
S6.8.6	Expander boards						
S6.8.7	Debug menu						For Application programming only. Speak to the factory to get instructions.

### 7.9.1 CHANGING THE LANGUAGE

You can change the language of the control panel. The possible languages are different in all language packages.

- 1 In the System menu (M6), find the Language selection page (S6.1) with the Browser buttons.

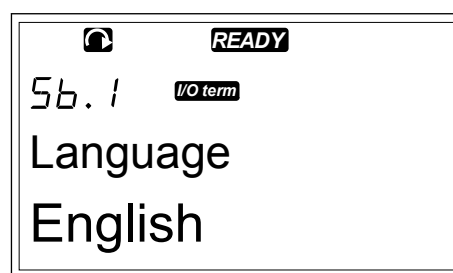

- 2 To go to the edit mode, push the Menu button Right. The name of the language starts to blink.

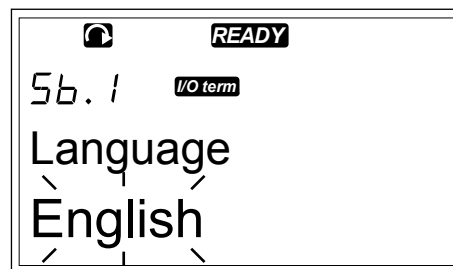

- 3 To select the language for the control panel texts, use the Menu buttons Up and Down.
- 4 To accept the selection, push the Enter button. The name of the languages stops to blink and all text information on the control panel shows in the language you selected.



### 7.9.2 CHANGING THE APPLICATION

In the Application selection page (S6.2), you can change the application. When you change the application, all parameters are reset.

- 1 In the System menu (M6), find the Application selection page (S6.2) with the Browser buttons.

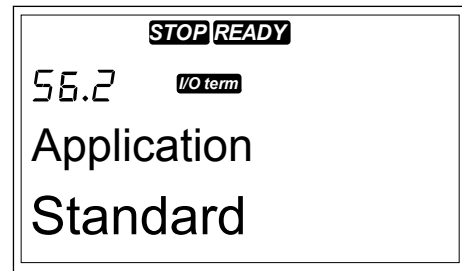

- 2 Push the Menu button Right.
- 3 To go to the edit mode, push the Menu button Right. The name of the application starts to blink.

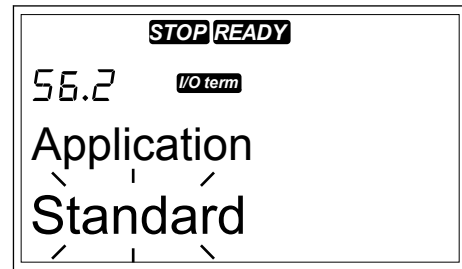

- 4 Scroll through the applications with the Browser buttons and select a different application.
- 5 To accept the selection, push the Enter button. The AC drive starts again and goes through the setup.

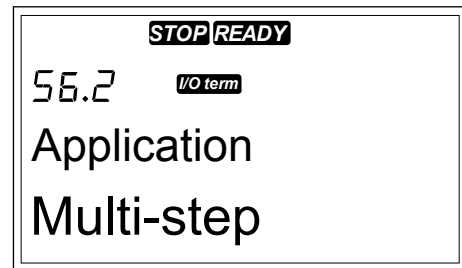

- 6 When the display shows the question 'Copy parameters?', you have 2 options:
  - To upload the parameters of the new application to the keypad, select Yes with the Browser buttons.
  - To keep the parameters of the application that was last used in the keypad, select No with the Browser buttons.

For more information on the Application Package, see VACON® NX All in One Application Manual.

### 7.9.3 COPY PARAMETERS (S6.3)

Use this function to copy parameters from one AC drive to a different AC drive or to save parameter sets in the internal memory of the AC drive.

You must stop the AC drive before you can copy or download parameters.

### SAVING PARAMETER SETS (PARAMETER SETS S6.3.1)

You can get the factory default values back or save 1-2 customised parameter sets. A parameter set includes all parameters of the application.

- 1 In the Copy parameters (S6.3) subpage, find the Parameter sets with the Browser buttons.
- 2 Push the Menu button Right.

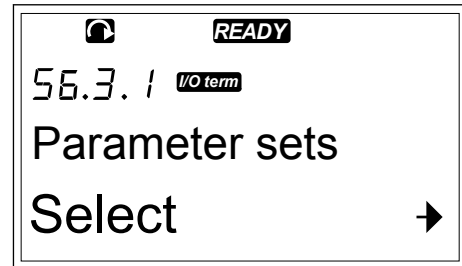

- 3 To go to the edit mode, push the Menu button Right. The text LoadFactDef starts to blink.

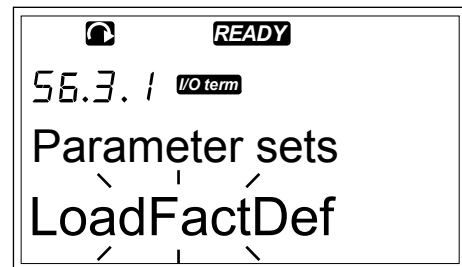

- 4 You have 5 options to select from:

- Select LoadFactDef to download again the factory default values.
- Select Store set 1 to save actual values of all parameters as set 1.
- Select Load set 1 to download the values in set 1 as the actual values.
- Select Store set 2 to save actual values of all parameters as set 2.
- Select Load set 2 to download the values in set 2 as the actual values.

Select the function with the Browser buttons.

- 5 To accept the selection, push the Enter button.

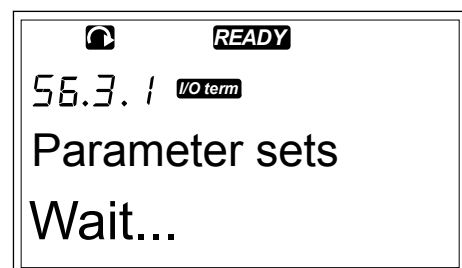

- 6 Wait until 'OK' shows on the display.

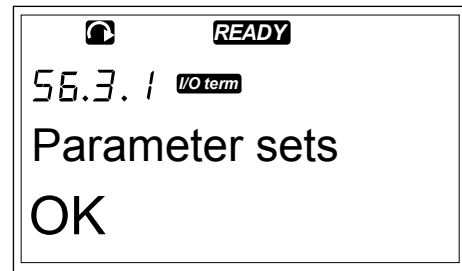

### UPLOADING PARAMETERS TO KEYPAD (UP TO KEYPAD, S6.3.2)

Use this function to upload all parameter groups to the control panel when the AC drive is stopped.

- 1 In the Copy parameters (S6.3) subpage, find the Up to keypad page (S6.3.2).
- 2 Push the Menu button Right.

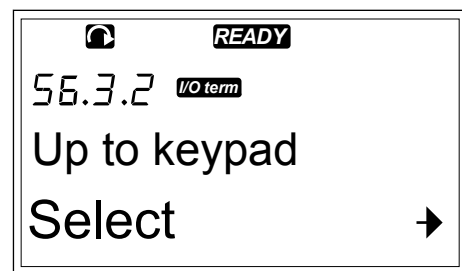

- 3 To go to the edit mode, push the Menu button Right. All param. starts to blink.

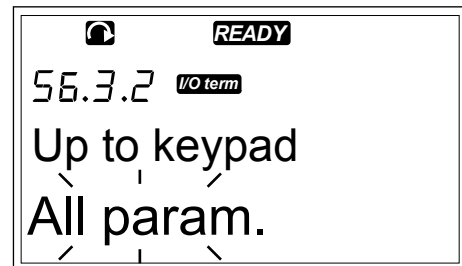

- 4 To accept the selection, push the Enter button.

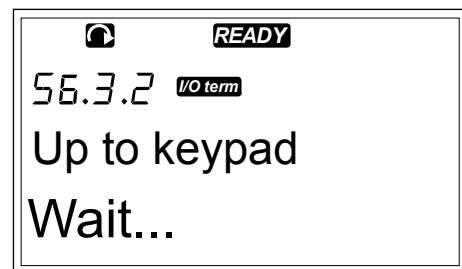

- 5 Wait until 'OK' shows on the display.

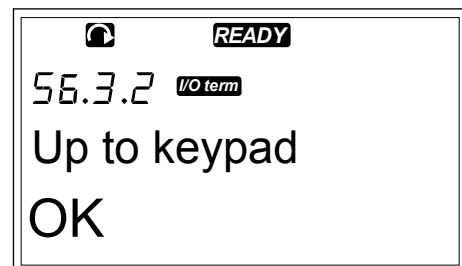

### DOWNLOADING PARAMETERS TO DRIVE (DOWN FROM KEYPAD, S6.3.3)

Use this function to download 1 or all parameter groups from the control panel to an AC drive when the AC drive is stopped.

- 1 In the Copy parameters (S6.3) subpage, find the Down from keypad page (S6.3.3).
- 2 Push the Menu button Right.
- 3 To go to the edit mode, push the Menu button Right.
- 4 Use the Browser buttons to select 1 of these 3 options:
  - All parameters
  - All parameters but the motor nominal value parameters (All. no motor)
  - Application parameters
- 5 To accept the selection, push the Enter button.
- 6 Wait until 'OK' shows on the display.

### ACTIVATING OR DEACTIVATING THE AUTOMATIC PARAMETER BACKUP (P6.3.4)

On this page you can activate or deactivate the parameter backup.

- 1 In the Copy parameters (S6.3) subpage, find the Automatic parameter backup page (S6.3.4).
- 2 To go to the edit mode, push the Menu button Right.
- 3 You have 2 options:
  - To activate the Automatic parameter backup, select Yes with the Browser buttons.
  - To deactivate the Automatic parameter backup, select No with the Browser buttons.

When the Automatic parameter backup is active, the control panel makes a copy of the parameters of the application. Each time you change a parameter, the keypad backup is automatically updated.



#### NOTE!

When you change the application, the parameters in the parameter settings on page S6.3.1 are deleted. To copy parameters from one application to a different application, you must first upload them to the control panel.

### 7.9.4 COMPARING THE PARAMETERS

In the Parameter comparison submenu (S6.4), you can compare the actual parameter values to the values of your customised parameter sets and those uploaded to the control keypad. You can compare the actual values to Set 1, Set 2, Factory Settings and Keypad Set.

- 1 In the Copy parameters (S6.3) subpage, find the Comparing parameters submenu with the Browser buttons.

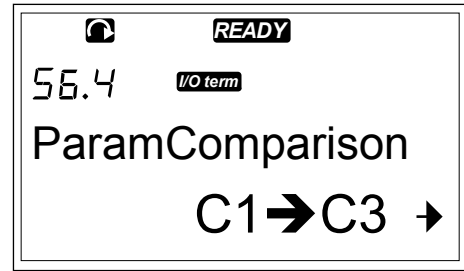

- 2 Push the Menu button Right. The actual parameter values are first compared to those of the customised parameter Set 1. If no differences are found, '0' shows on the bottom line. If there are differences, the display shows the number of the differences (for example, 'P1->P5' = 5 different values).

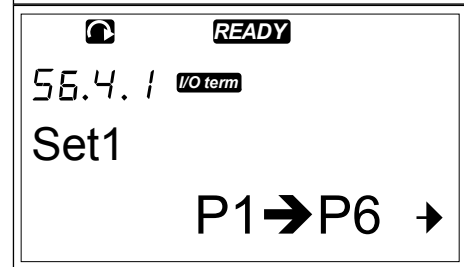
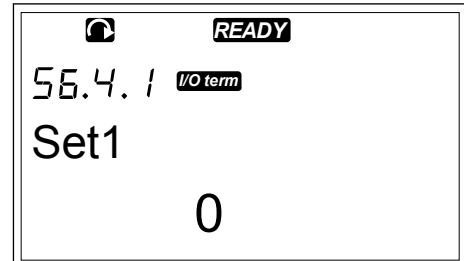

- 3 To compare the values to a different set, use the Browser buttons.
- 4 To go to the page with the parameter values, push the Menu button Right. In the display that opens, the value on the Description line (A) is the value of the selected set and the value on the value line (B) is the actual value.

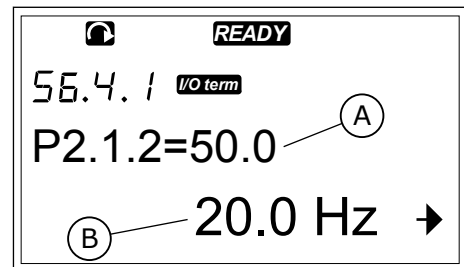

- 5 To go to the edit mode, push the Menu button Right. The actual value starts to blink.

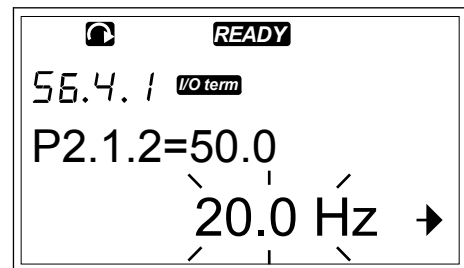

- 6 To change the actual value, use the Browser buttons, or change the value digit by digit with the Menu button Right.

## 7.9.5 SECURITY



### NOTE!

Use a password to go to the Security submenu. Keep the password in a safe location!

1 To find the Security submenu, scroll down in the System menu until the location indication S6.5 shows on the first line of the display.

2 To go to the Security submenu from the System menu, push the Menu button Right.

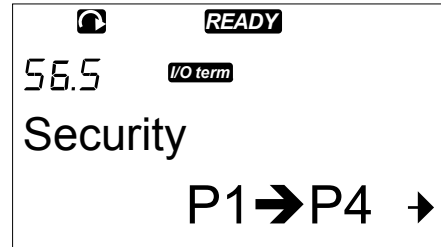

### 7.9.5.1 Password (S6.5.1)

You can prevent unauthorised changes in the application selection with the Password function (S6.5.1). By default, the password is not active.

#### SETTING A PASSWORD

1 In Security submenu, push the Menu button Right.

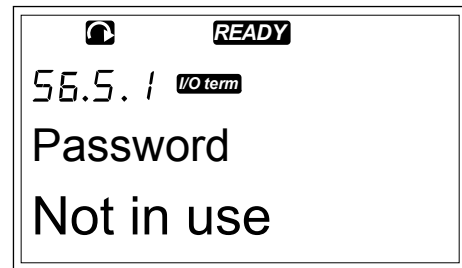

2 To go to the edit mode, push the Menu button Right. The display shows '0' that blinks.

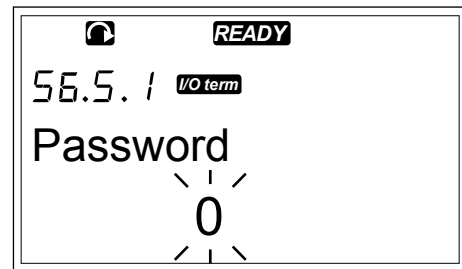

3 You have 2 options to set a password: with the Browser buttons or by digits. The password can be a number between 1 and 65535.

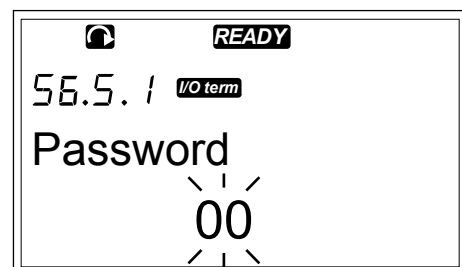

- Push the Browser buttons Up and Down to find a number.
- Push the Menu button Right. A second '0' shows on the display.
  1. Push the Browser buttons to set digit on the right.
  2. Push the Menu button Left, and set the digit on the left.
  3. To add a third digit, push the Menu button Left. Set up to 5 digits with Menu and Browser buttons.
- 4 To accept the new password, push the Enter button. The password activates after the Timeout time (P6.6.3) (see Chapter 7.9.6.3 *Timeout time (P6.6.3)*).

**NOTE!**

Keep the password in a safe location! You cannot change the password if you do not first give a valid password.

**ENTERING A PASSWORD**

When you have set the password and try to go to a submenu that has password protection, the display shows 'Password?'

- 1 When the display shows 'Password?', give the password with the Browser buttons.

**DEACTIVATING THE PASSWORD FUNCTION**

- 1 Find the Password (S6.5.1) in the Security menu with the Browser buttons.
- 2 To go to the edit mode, push the Menu button Right.
- 3 Set value '0' for the password.

**7.9.5.2 Parameter lock (P6.5.2)**

With Parameter lock, you can prevent changes to the parameters.

If the parameter lock is active, the text 'locked' shows on the display when you try to edit a parameter value.

**NOTE!**

This function does not prevent unauthorised changes of parameter values.



## LOCKING A PARAMETER

- 1 In the Security menu (M6), find the Parameter lock (P6.5.2) with the Browser buttons.

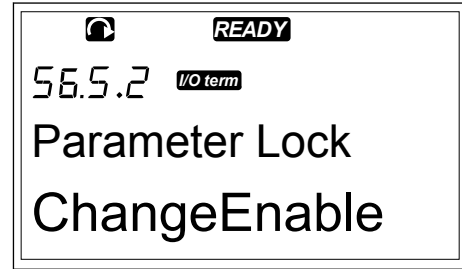

- 2 To go to the edit mode, push the Menu button Right.

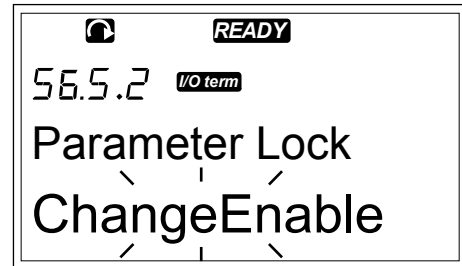

- 3 To change the parameter lock status, use the Browser buttons.

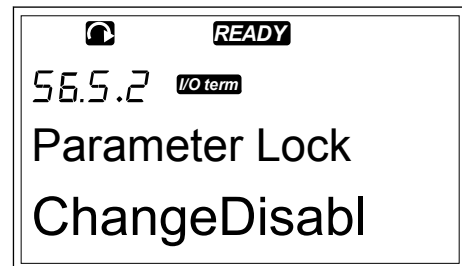

- 4 To accept the change, push the Enter button.

### 7.9.5.3 Start-up wizard (P6.5.3)

The Startup wizard helps in the commissioning of the AC drive. By default, the Startup wizard is active. In the Startup wizard, you set this information:

- the language
- the application
- the values for a set of parameters that are same to all applications
- the values for a set of application-specific parameters

**Table 46: Using a Startup Wizard**

Action	Button
Accepting a value	Enter button
Scrolling for options	Browser buttons Up and Down
Changing a value	Browser buttons Up and Down

## ACTIVATING/DEACTIVATING THE STARTUP WIZARD

1 In the System menu (M6), find the page P6.5.3.



2 To go to the edit mode, push the Menu button Right.



- 3
- To activate the Startup wizard, select Yes with the Browser buttons.
  - To deactivate the Startup wizard, select No with the Browser buttons.



4 To accept the selection, push the Enter button.

### 7.9.5.4 Multimonitoring items (P6.5.4)

You can monitor 3 actual values at the same time (see Chapter 7.4 *Using the Monitoring menu (M1)* and chapter Monitoring values in the Application Manual of your application). You can change the values that are monitored with other values if you first enable the change in the Multimonitoring items page (P6.5.4).

## ENABLING/DISABLING THE CHANGE OF MULTIMONITORING ITEMS

1 In the Security submenu, find Multimonitoring items page (P6.5.4) with the Browser buttons.

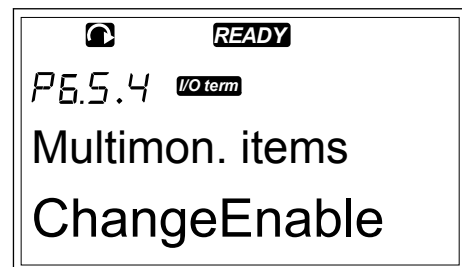

- 2 To go to the edit mode, push the Menu button Right. 'Change Enabled' starts to blink.

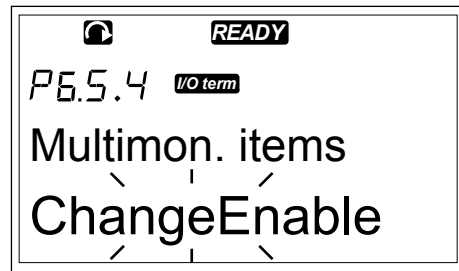

- 3 Use Browser buttons Up and Down to select Change Enabled or Change Disabled.

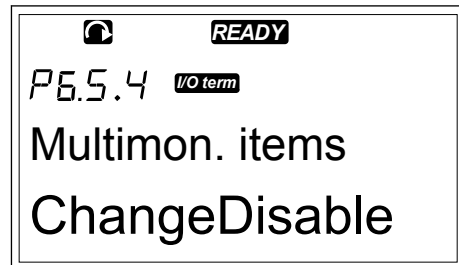

- 4 Accept the selection with the Enter button.

### 7.9.6 KEYPAD SETTINGS

In the Keypad settings submenu in the System menu you can make changes to your control panel.

1 In the System menu (M6), find the Keypad settings submenu (S6.6) with the Browser buttons. In the submenu, there are 5 pages (P#) that control the panel operation:

- Default page (P6.6.1)
- Default page in the operating menu (P6.6.2)
- Timeout time (P6.6.3)
- Contrast adjustment (P6.6.4)
- Backlight time (P6.6.5)

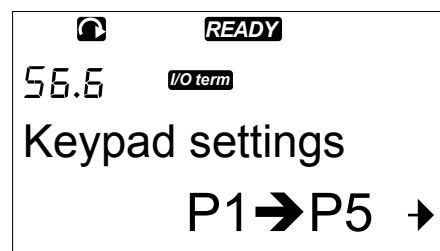

#### 7.9.6.1 Default page (P6.6.1)

With Default page, you can set the location (page) to which the display automatically moves after the Timeout time (see below) or after you set the panel on. If the Default Page value is 0, the function is not activated. When the Default page is not used, the control panel shows the page that was last showed on the display.

## CHANGING THE DEFAULT PAGE

- 1 In the Keypad settings submenu, find the Default page subpage (P6.6.1) with the Browser buttons.

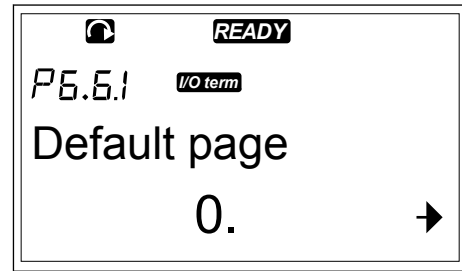

- 2 To go to the edit mode, push the Menu button Right.

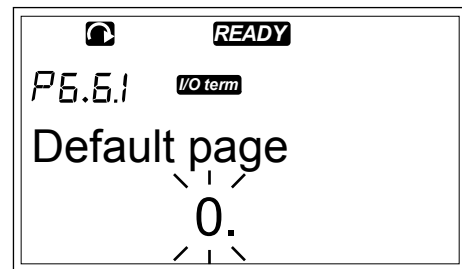

- 3 To change the number of the Main menu, use the Browser buttons.

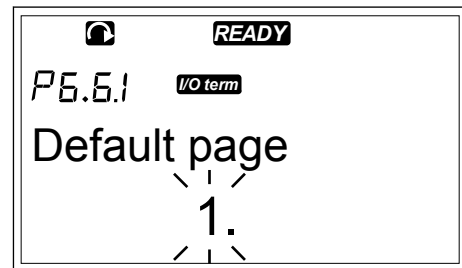

- 4 To edit the number of the submenu/page, push the Menu button Right. Change the number of the submenu/page with the Browser buttons.
- 5 To edit the third level page number, push the Menu button Right. Change the number of the third level page with the Browser buttons.
- 6 To accept the new default page value, push the Enter button.

### 7.9.6.2 Default page in the Operating menu (P6.6.2)

In this submenu, you can set the default page in the Operating menu. The display automatically moves to the set page after the Timeout time (see Chapter 7.9.6.3 *Timeout time (P6.6.3)*) or after you set the control panel on. For instructions, see Chapter 7.9.6.1 *Default page (P6.6.1)*.



#### **NOTE!**

The Operating menu is only available in special applications.

### 7.9.6.3 Timeout time (P6.6.3)

The Timeout time sets the time after which the control panel display goes back to the Default page (P6.6.1). For more information on setting the Default page, see Chapter 7.9.6.1 *Default page (P6.6.1)*.

## SETTING THE TIMEOUT TIME

- 1 In the Keypad settings submenu, find the Timeout time subpage (P6.6.3) with the Browser buttons.

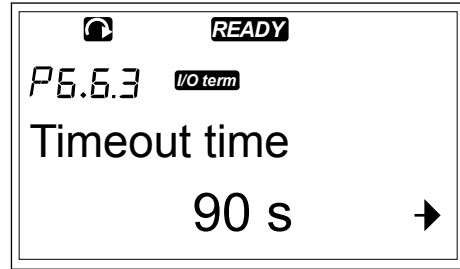

- 2 To go to the Edit mode, push the Menu button Right.

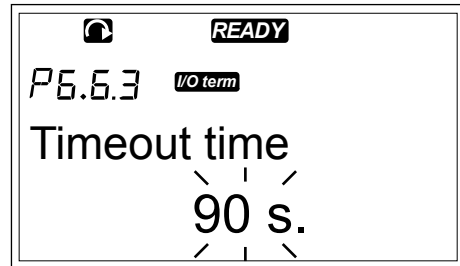

- 3 To set the timeout time, use the Browser buttons.

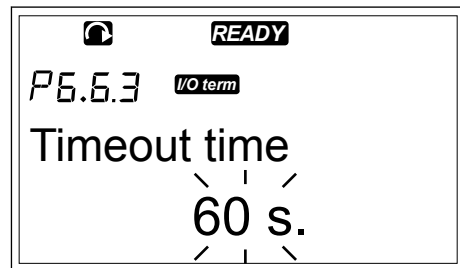

- 4 To accept the change, push the Enter button.



### NOTE!

If the Default page value is 0, the Timeout time setting has no effect.

#### 7.9.6.4 Contrast adjustment (P6.6.4)

If the display is not clear, you can adjust its contrast with the same procedure as that for the timeout time setting (see Chapter 7.9.6.3 *Timeout time (P6.6.3)*).

#### 7.9.6.5 Backlight time (P6.6.5)

You can set the time the backlight stays on until it goes off. You can select a value between 1 and 65535 minutes or 'Forever'. For the value setting procedure, see Chapter 7.9.6.3 *Timeout time (P6.6.3)*.

## 7.9.7 HARDWARE SETTINGS



### NOTE!

Use a password to go the Hardware settings submenu (see Chapter 7.9.5.1 *Password (S6.5.1)*). Keep the password in a safe location!

1 To find the Hardware settings submenu, scroll down in the System menu until the location indication S6.7 shows on the first line of the display.

2 To go to the Hardware settings submenu from the System menu, push the Menu button Right.

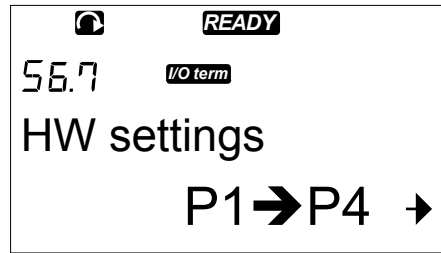

In the Hardware settings submenu (S6.7) in the System menu you can control these functions of the hardware in your AC drive:

- Internal brake resistor connection
- Fan control
- HMI acknowledge timeout
- HMI retry
- Sine filter
- Pre-charge mode.

7.9.7.1 Internal brake resistor connection (P6.7.1)

Use this function to tell the AC drive if the internal brake resistor is connected or not. If your AC drive has an internal brake resistor, the default value of this parameter is Connected. We recommend that you change this value to 'Not conn.' if:

- it is necessary to install an external brake resistor to increase the braking capacity
- the internal brake resistor is disconnected for some reason.

**SETTING THE INTERNAL BRAKE RESISTOR CONNECTION**

1 In the Hardware settings submenu, find the Internal brake resistor connection (6.7.1) subpage with the Browser buttons.

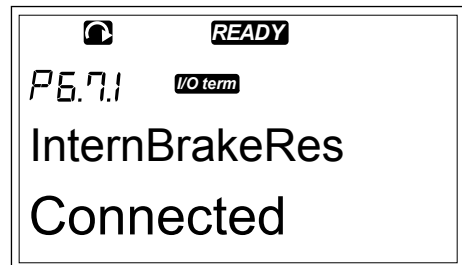

2 To go to the edit mode, push the Menu button Right.

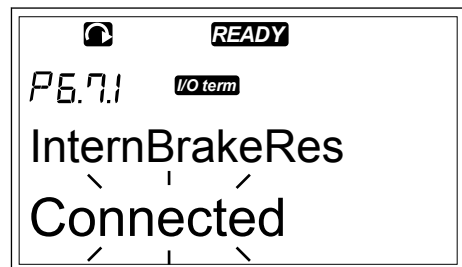

- To change the internal brake resistor status, use the Browser buttons.



- To accept the change, push the Enter button.

**NOTE!**

The brake resistor is available as optional equipment for all sizes. It can be installed internally in enclosure sizes FR4 to FR6.

### 7.9.7.2 Fan control (P6.7.2)

Use this function to control the cooling fan of the AC drive. You have 4 options to select from:

- Continuous (default setting). The fan is always on when the power is on.
- Temperature. The fan starts automatically when the heat sink temperature goes to 60 °C (140 °F) or when the AC drive operates. The fan stops about a minute after one of these:
  - the heat sink temperature falls to 55 °C (131 °F)
  - the AC drive stops
  - the Fan control value is changed from Continuous to Temperature
- First start. When power is on, the fan is in the stop state. When the AC drive gets the first start command, the fan starts.
- Calc temp. The fan function agrees to the calculated IGBT temperature:
  - If the IGBT temperature is more than 40 °C (104 °F), the fan starts.
  - If the IGBT temperature is below 30°C (86 °F), the fan stops.

**NOTE!**

As the default temperature at power-up is 25 °C (77 °F), the fan does not start immediately.

## CHANGING THE FAN CONTROL SETTING

- In the Hardware settings submenu, find the Fan control settings (6.7.2) with the Browser buttons.

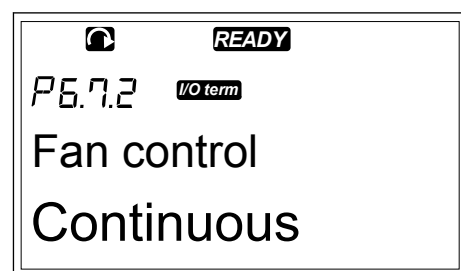

- 2 To go to the edit mode, push the Menu button Right.  
The used value starts to blink.

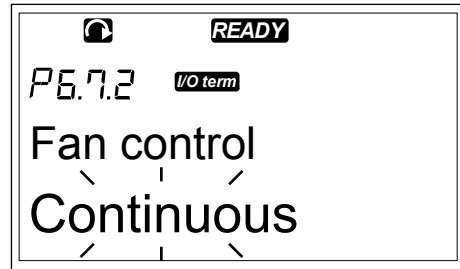

- 3 To select the fan mode, use the Browser buttons.

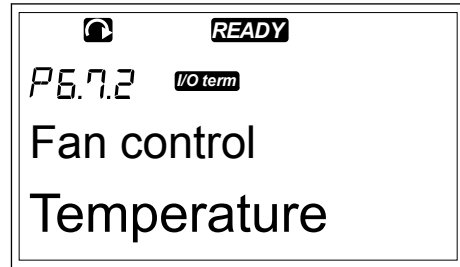

- 4 To accept the change, push the Enter button.

#### 7.9.7.3 HMI acknowledge timeout (P6.7.3)

Use this function to change the timeout of the HMI acknowledgement time. Use this when there is more delay in the RS-232 transmission, for example, when modems are used for communication over longer distances.



#### NOTE!

Do not change the default values of parameters 6.7.3 and 6.7.4 (200 and 5) if the AC drive is connected to the PC with a cable. If the AC drive is connected to the PC with a modem and the messages are transferred with a delay, set the values for parameter 6.7.3 to agree these delays. For example, if the transfer delay between the AC drive and the PC is 600 ms, make these settings:

#### Example:

- Set the value of parameter 6.7.3 to 1200 ms (2 x 600, sending delay + receiving delay)
- Set the [Misc]-part of the file NCDriver.ini to agree with the settings:
  - Retries = 5
  - AckTimeOut = 1200
  - TimeOut = 6000

Do not use intervals shorter than the AckTimeOut-time in the NC-Drive monitoring.



## CHANGING THE HMI ACKNOWLEDGEMENT TIME

- 1 In the Hardware settings submenu, find the HMI acknowledgement time with the Browser buttons.



- 2 To go to the edit mode, push the Menu button Right.

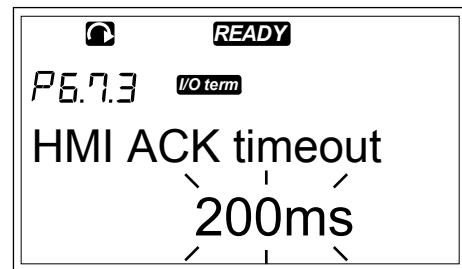

- 3 To change the acknowledgement time, use the Browser buttons.
- 4 To accept the change, push the Enter button.

### 7.9.7.4 Number of retries to receive HMI acknowledgement (P6.7.4)

Use this parameter to set the number of times the AC drive tries to receive acknowledgement if it does not receive it during the acknowledgement time (P6.7.3) or if the received acknowledgement is defective.

## CHANGING THE NUMBER OF RETRIES TO RECEIVE HMI ACKNOWLEDGEMENT

- 1 In the Hardware settings submenu, find the Number of retries to receive HMI acknowledgement with the Browser buttons.
- 2 To go to the edit mode, push the Menu button Right. The value starts to blink.
- 3 To change the number of retries, use the Browser buttons.
- 4 To accept the change, push the Enter button.

### 7.9.7.5 Sine filter (P6.7.5)

When you use an old motor or a motor that was not made to be used with an AC drive, it may be necessary to use a sine filter. A sine filter makes the sine form of the voltage better than a du/dt filter.

If you have a sine filter in your AC drive, to put it into operation set this parameter to Connected.

### 7.9.7.6 Pre-charge mode (P6.7.6)

If you have an FI9 or a larger inverter unit, select 'Ext.ChSwitch' to control an external charge switch.

## 7.9.8 SYSTEM INFO

The System info submenu (S6.8) contains information on the hardware, software and operation of the AC drive.

1 To find the System info submenu, scroll down in the System menu until the location indication S6.8 shows on the first line of the display.

2 To go to the System info submenu from the System menu, push the Menu button Right.

### 7.9.8.1 Total counters (S6.8.1)

The Total counters page (S6.8.1) has information on the AC drive operation times. The counters show the total number of MWh, operation days and operation hours. The Total counters cannot be reset.



#### NOTE!

The Power On time counter (days and hours) counts always, when the AC power is on. In new system software versions, the counter does not count when control unit runs on +24V only.

**Table 47: Counter pages**

Page	Counter	Example
C6.8.1.1.	MWh counter	
C6.8.1.2.	Power On day counter	Value on display is 1.013. The drive has operated for 1 year and 13 days.
C6.8.1.3	Power On hour counter	Value on display is 7:05:16. The drive has operated for 7 hours 5 minutes and 16 seconds.

### 7.9.8.2 Trip counters (S6.8.2)

The Trip counters page (S6.8.2) has information on counters that you can reset, that is, you can set their value back to 0. See *Table 47 Counter pages* for examples.



#### NOTE!

The trip counters count only when the motor is in RUN state.

**Table 48: Trip counters**

Page	Counter
T6.8.2.1	MWh counter
T6.8.2.3	Operation day counter
T6.8.2.4	Operation hour counter

**RESETTING THE TRIP COUNTERS**

- 1 In the System info submenu, find the Trip counters page (6.8.2) with the Browser buttons.

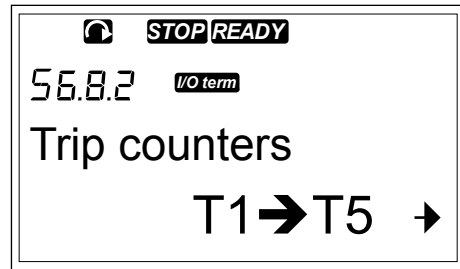

- 2 To go to the Clear MWh counter page (6.8.2.2) or to the Clear Operation time counter page (6.8.2.5), use the Menu button Right.

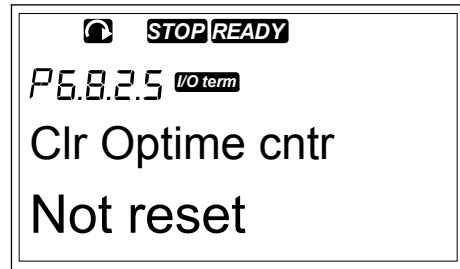

- 3 To go to the edit mode, push the Menu button Right.

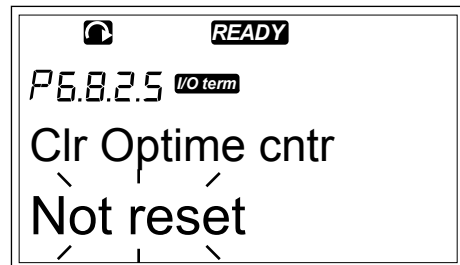

- 4 To select Reset, push Browser buttons Up and Down.

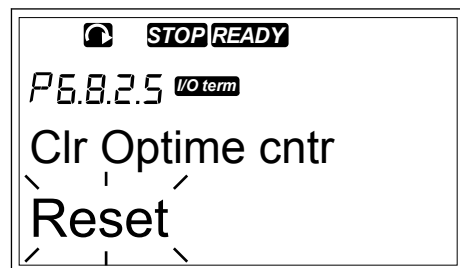

5 To accept the selection, push the Enter button.



6 The display shows again Not reset.



### 7.9.8.3 Software [S6.8.3]

The Software information page includes information on the AC drive software.

**Table 49: Software information pages**

Page	Content
6.8.3.1	Software package
6.8.3.2	System software version
6.8.3.3	Firmware interface
6.8.3.4	System load

### 7.9.8.4 Applications [S6.8.4]

The Applications submenu [S6.8.4] contains information on all applications on the AC drive.

**Table 50: Applications information pages**

Page	Content
6.8.4.#	Name of application
6.8.4.#.1	Application ID
6.8.4.#.2	Version
6.8.4.#.3	Firmware interface

## EXAMINING THE APPLICATION PAGE

- 1 In the System info submenu, find the Applications page with the Browser buttons.

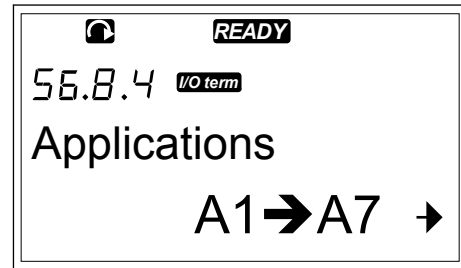

- 2 To go to the Applications page, push the Menu button Right.

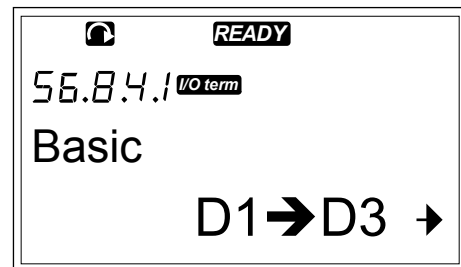

- 3 To select the application, use the Browser buttons. There are as many pages as there are applications on the AC drive.

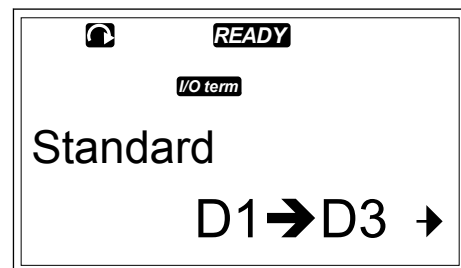

- 4 To go to the Information pages, use the Menu button Right.



- 5 To see the different pages, use the Browser buttons.

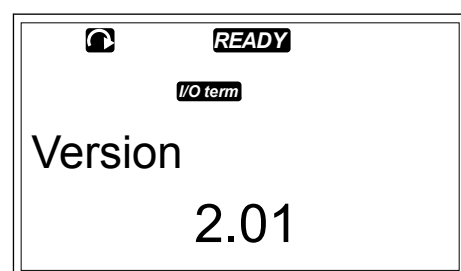

#### 7.9.8.5 Hardware (S6.8.5)

The Hardware information page includes information on the AC drive hardware.

**Table 51: Hardware information pages**

Page	Content
6.8.5.1	Power unit type code
6.8.5.2	Nominal voltage of the unit
6.8.5.3	Brake chopper
6.8.5.4	Brake resistor
6.8.5.5	Serial number

**7.9.8.6 Expander boards (S6.8.6)**

In the Expander boards pages you find information about the basic and option boards connected to the control board (see Chapter 6 Control unit).

**CHECKING THE STATUS OF AN EXPANDER BOARD**

- 1 In the System info submenu, find the Expander boards page (6.8.6) with the Browser buttons.

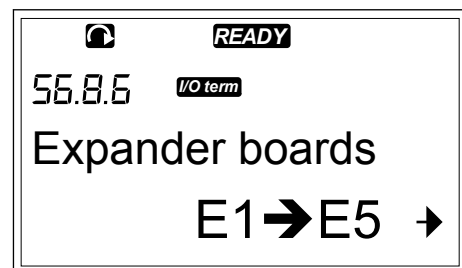

- 2 To go to the Expander boards page, push the Menu button Right.

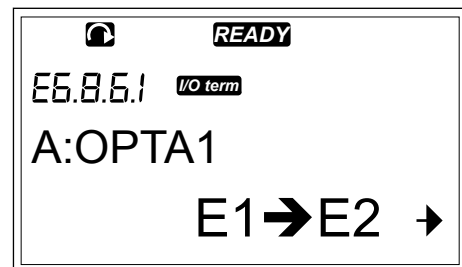

- 3 To select the board, use the Browser buttons. If no board is connected to the slot, the display shows 'no board'. If a board is connected to a slot but there is no connection, the display shows 'no conn.'. See Chapter 6 Control unit and Fig. 1 Basic and option board connections on the control board for more information on the boards.

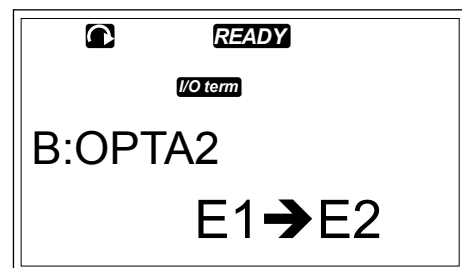

- 4 To see the status of the board, push the Menu button Right.

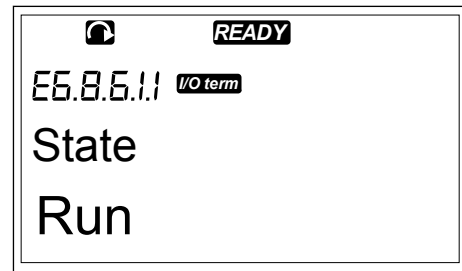

- 5 To see the program version of the board, push the Browser button Up or Down.

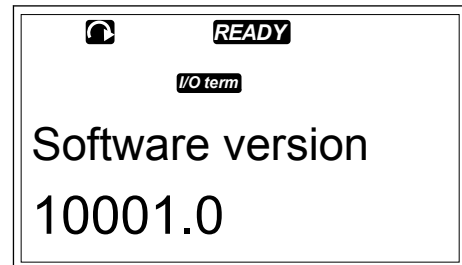

For more information on the parameters of the expander boards, see Chapter 7.10 *Using the Expander board menu (M7)*.

#### 7.9.8.7 Debug menu (S6.8.7)

The Debug menu is for advanced users and application designers. Speak to the factory to get instructions, if it is necessary.

## **7.10 USING THE EXPANDER BOARD MENU (M7)**

In the Expander board menu you can

- see which expander boards are connected to the control board
- find and edit the expander board parameters.

**Table 52: Expander board parameters (board OPTA1)**

Code	Parameter	Min	Max	Default	Cust	Selections
P7.1.1.1	AI1 mode	1	5	3		1 = 0-20 mA 2 = 4-20 mA 3 = 0-10 V 4 = 2-10 V 5 = -10...+10 V
P7.1.1.2	AI2 mode	1	5	1		See P7.1.1.1
P7.1.1.3	A01 mode	1	4	1		1 = 0-20 mA 2 = 4-20 mA 3 = 0-10 V 4 = 2-10 V

**EXAMINING THE CONNECTED EXPANDER BOARDS**

- 1 To find the Expander board menu, scroll down in the Main menu until the location indication M7 shows on the first line of the display.

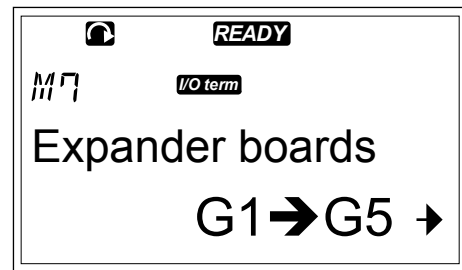

- 2 To go to the Expander board menu from the Main menu, push the Menu button Right.

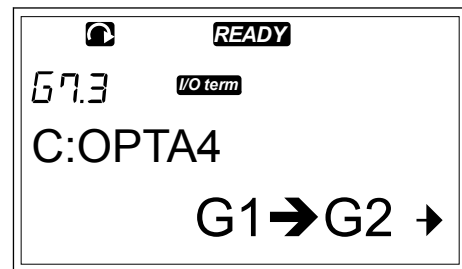

- 3 To examine the list of connected expander boards, use the Browser buttons Up and Down.

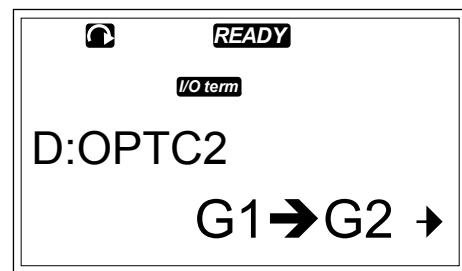



- To see the information on the expander board, push the Menu button Right.

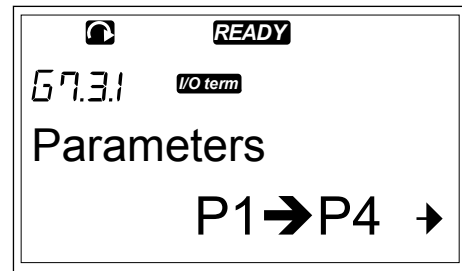

## FINDING THE EXPANDER BOARD PARAMETERS

- Find the expander board with the Browser and Menu buttons.

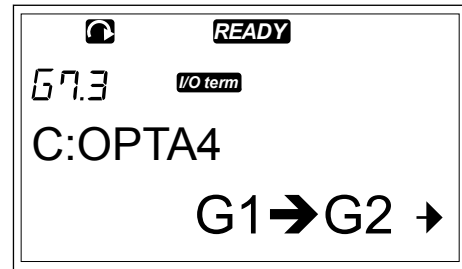

- To see the information on the expander board, push the Menu button Right.

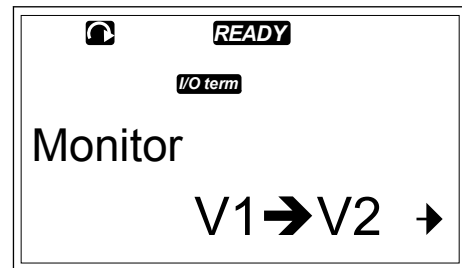

- To scroll to the Parameters use the Browser buttons Up and Down.

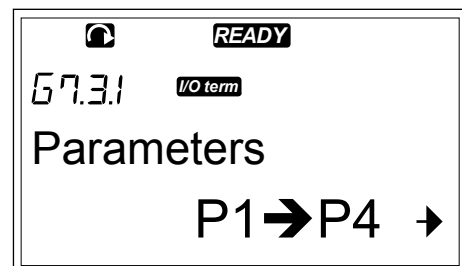

- To examine the list of parameters, push the Menu button Right.

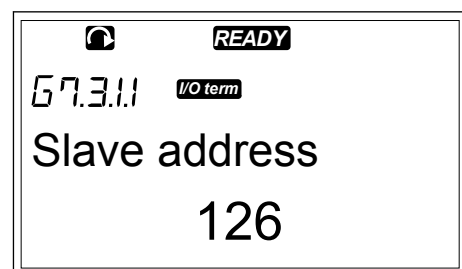

- To scroll through the parameters, use the Browser buttons Up and Down.

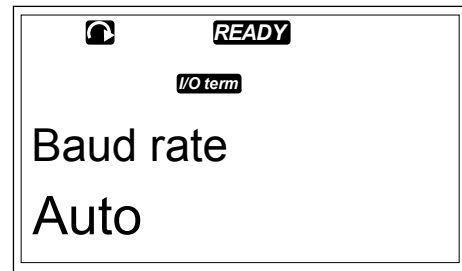

- To go to the edit mode, push the Menu button Right. For instructions on how to edit the parameter values, see Chapter 7.5 *Using the Parameter menu (M2)*.

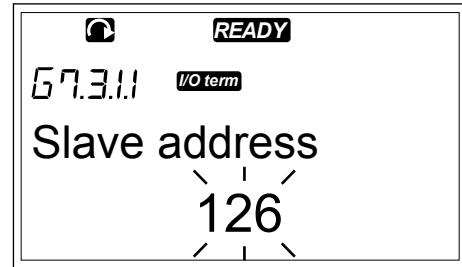

## 7.11 FURTHER KEYPAD FUNCTIONS

The VACON® NX control keypad has more application related functions. See VACON® NX Application Package for more information.

## 8 COMMISSIONING AND ADDITIONAL INSTRUCTIONS

### 8.1 COMMISSIONING SAFETY

Before you start the commissioning, read these warnings.

**WARNING!**

Do not touch the internal components or the circuit boards of the drive when the drive is connected to mains. These components are live. A contact with this voltage is very dangerous. The galvanically isolated control terminals are not live.

**WARNING!**

Do not touch the motor cable terminals U, V, W or the brake resistor terminals when the drive is connected to mains. These terminals are live when the drive is connected to mains, also when the motor does not operate.

**WARNING!**

Do not make connections to or from the AC drive when it is connected to mains. There is a dangerous voltage.

**WARNING!**

To do work on the connections of the drive, disconnect the drive from mains. Wait 5 minutes before you open the cover of the drive. Then use a measuring device to make sure that there is no voltage. The connections of the drive are live 5 minutes after it is disconnected from mains.

**WARNING!**

Before you do electrical work, make sure that there is no voltage.

**WARNING!**

Do not touch the relay board terminals or other I/O board terminals than the control terminals. They can have a dangerous voltage also when the drive is disconnected from mains.

**WARNING!**

Before you connect the drive to mains, make sure that the front cover and the cable cover of the drive are closed. The connections of the AC drive are live when the drive is connected to mains.

**WARNING!**

Do not touch the side of the AC drive FR8 with hands when it operates. The surface is hot.

**WARNING!**

Do not install the AC drive FR6 on a surface that is not fireproof. When the AC drive FR6 operates, the rear surface of the drive is hot.

## 8.2 COMMISSIONING OF THE DRIVE

Read the safety instructions in Chapters 2 *Safety* and 8.1 *Commissioning safety* and obey them.

**After the installation:**

- Make sure that the motor is installed correctly.
- Make sure that the motor is not connected to mains.
- Make sure that the AC drive and the motor are grounded.
- Make sure that you select the mains cable, the brake cable, and the motor cable correctly [see Chapter 5.3 *Cable dimensioning and selection*].
- Make sure that the control cables are as far as possible from the power cables. See Chapter 5.7 *Cable installation*.
- Make sure that the shields of the shielded cables are connected to a grounding terminal that is identified with ⊕ .
- Do a check of the tightening torques of all the terminals.
- Make sure that no power correction capacitors are connected to the motor cable.
- Make sure that the cables do not touch the electrical components of the drive.
- Make sure that the common inputs of the digital input groups are connected to +24 V or ground of the control terminal or the external power source.
- Do a check of the quality and quantity of the cooling air. See chapter 4.5 *Cooling*.
- Make sure that there is no condensation on the inner surfaces of the AC drive.
- Make sure that there are no unwanted objects in the installation space.
- Before you connect the drive to mains, do a check of the installation and the condition of all the fuses and other protective devices.

## 8.3 OPERATION OF THE MOTOR

### 8.3.1 CHECKS BEFORE STARTING THE MOTOR

**Before you start the motor, do these checks.**

- Make sure that all the START and STOP switches that are connected to the control terminals are in the STOP position.
- Make sure that you can start the motor safely.
- Set the parameters of group 1 (see VACON® All in One Application Manual) to agree with the requirements of your application. To find the necessary values for the parameters, see the motor nameplate. Set these parameters at a minimum:
  - Motor nominal voltage
  - Motor nominal frequency
  - Motor nominal speed
  - Motor nominal current
- Set the maximum frequency reference (that is, the maximum speed of the motor) to agree with the motor and the device that is connected to the motor.

### 8.3.2 THE RUN TEST WITHOUT THE MOTOR

Do either Test A or Test B:

#### Test A: Controls from the control terminals

1. Turn the Start/Stop switch to ON position.
2. Change the frequency reference (potentiometer).
3. Do a check in the Monitoring menu M1 that the value of Output frequency changes the equivalent quantity to the frequency reference.
4. Turn the Start/Stop switch to OFF position.

#### Test B: Control from the control keypad

1. Change the control from the control terminals to the keypad. For the instructions, see Chapter 7.6.1.1 *Changing the control place*.
2. Push the Start button on the keypad.
3. Go to the Keypad control menu (M3) and Keypad Reference submenu (Chapter 7.6.2 *The keypad reference submenu (P3.2)*). To change the frequency reference, use the Browser buttons.
4. Do a check in the Monitoring menu M1 that the value of Output frequency changes the equivalent quantity to the frequency reference.
5. Push the Stop button on the keypad.

### 8.3.3 START-UP TEST

Do the start-up tests without the motor connected to the process, if possible. If this is not possible, make sure that it is safe to do each test before you do it. Make sure that the other workers near you know that you do the tests.

1. Turn the supply voltage off and wait until the drive stops. See Chapter 8.2 *Commissioning of the drive*, step 5.
2. Connect the motor cable to the motor and to the motor cable terminals of the AC drive.
3. Make sure that all Start/Stop switches are in Stop positions.
4. Turn the mains switch ON.
5. Do again the Run test A or B, see Chapter 8.3.2 *The Run test without the motor*.

### 8.3.4 IDENTIFICATION RUN

Make the Identification Run. The Identification Run helps to tune the motor and drive related parameters. It is a tool that you can use in commissioning to find the best possible parameter values for most drives. The automatic motor identification calculates or measures the necessary motor parameters for the best possible motor and speed control. For more information on the Identification Run, see VACON® All in One Application Manual, parameter ID631.

### 8.3.5 CONNECTING THE MOTOR TO THE PROCESS

If you did the start-up test without the motor connected, connect the motor to the process.

- Before you do the tests, make sure that it is safe to do each test before you do it.
- Make sure that the other workers near you know that you do the tests.
- Do the Run test A or B, see Chapter 8.3.2 *The Run test without the motor*.

## 8.4 MEASURING THE CABLE AND MOTOR INSULATION

Do these checks if necessary.

### The insulation checks of the motor cable

1. Disconnect the motor cable from the terminals U, V, and W and from the motor.
2. Measure the insulation resistance of the motor cable between phase conductors 1 and 2, between phase conductors 1 and 3, and between phase conductors 2 and 3.
3. Measure the insulation resistance between each phase conductor and the grounding conductor.
4. The insulation resistance must be  $>1 \text{ M}\Omega$  at the ambient temperature of  $20 \text{ }^\circ\text{C}$  ( $68 \text{ }^\circ\text{F}$ ).

### The insulation checks of the mains cable

1. Disconnect the mains cable from the terminals L1, L2, and L3 and from mains.
2. Measure the insulation resistance of the mains cable between phase conductors 1 and 2, between phase conductors 1 and 3, and between phase conductors 2 and 3.
3. Measure the insulation resistance between each phase conductor and the grounding conductor.
4. The insulation resistance must be  $>1 \text{ M}\Omega$  at the ambient temperature of  $20 \text{ }^\circ\text{C}$  ( $68 \text{ }^\circ\text{F}$ ).

### The insulation checks of the motor

1. Disconnect the motor cable from the motor.
2. Open the bridging connections in the motor connection box.
3. Measure the insulation resistance of each motor winding. The voltage must be the same or higher than the motor nominal voltage, but not higher than 1000 V.
4. The insulation resistance must be  $>1 \text{ M}\Omega$  at the ambient temperature of  $20 \text{ }^\circ\text{C}$  ( $68 \text{ }^\circ\text{F}$ ).
5. Obey the instructions of the motor manufacturer.

## 8.5 INSTALLATION IN AN IT SYSTEM

If your mains is impedance-grounded (IT), the AC drive must have the EMC protection level C4. If your drive has the EMC protection level C2, it is necessary to change it to C4. To do this, remove the EMC jumpers.

For equivalents of EMC levels in VACON® AC drives, see 9.3 *The compliance with the product standard IEC/EN 61800-3 + A1*.



### WARNING!

Do not make changes in the AC drive when it is connected to mains. The components of the drive are live when the drive is connected to mains.



### CAUTION!

Before you connect the AC drive to mains, make sure that the EMC level of the drive is correct. An incorrect EMC level can cause damage to the drive.

### 8.5.1 ENCLOSURE SIZES FR4, FR5, AND FR6

Change the EMC protection of the AC drive to level C4.

1. Open the cover of the AC drive.

- 2 To find the EMC jumpers, remove the cable cover.
- 3 Remove the EMC screw(s).

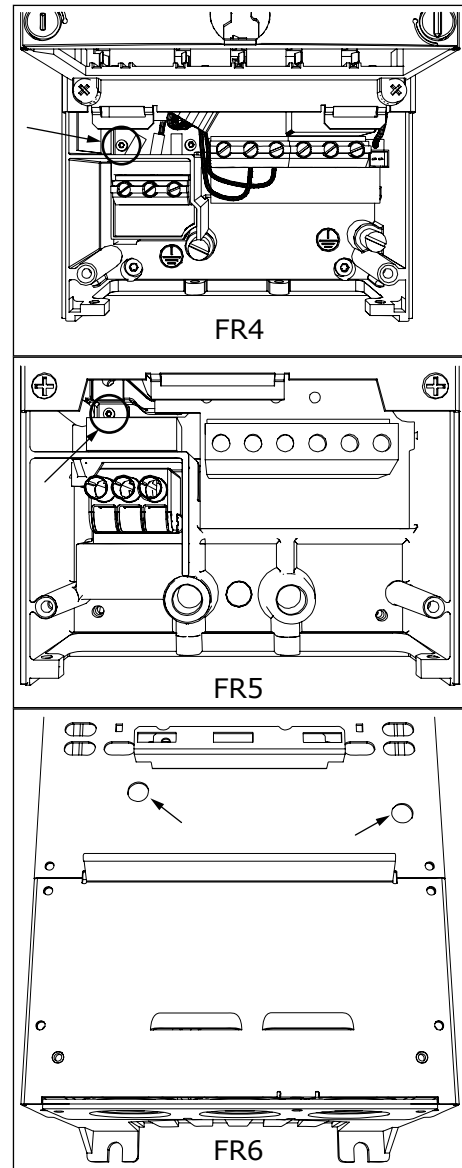

- 4 Close the cover of the AC drive. For the tightening torques of the screws, see *Table 5 The tightening torques of the cover screws*.
- 5 After the change, put a check mark to "EMC Level modified" and write the date on the "product modified" label (see 3.6 "Product modified" label). If the label is not attached at this time, attach it on the drive near the name plate.

### 8.5.2 ENCLOSURE SIZE FR7

Change the EMC protection of the AC drive to level C4.

- 1 Open the cover of the AC drive.
- 2 Open the cable cover of the AC drive.

- 3 Open the power unit cover of the AC drive.

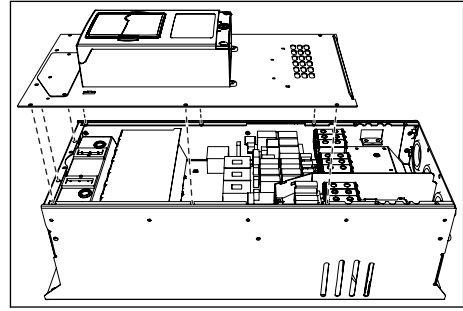

- 4 Remove the EMC screws.

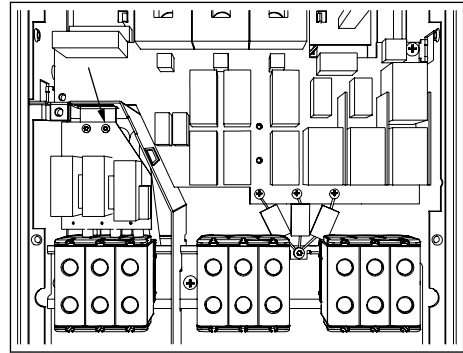

- 5 Remove the screw and replace with a plastic screw M4.

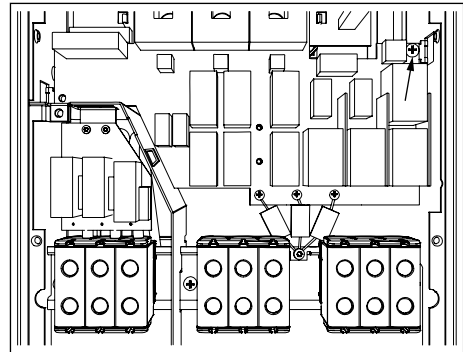

- 6 Cut the leads of the 3 capacitors.

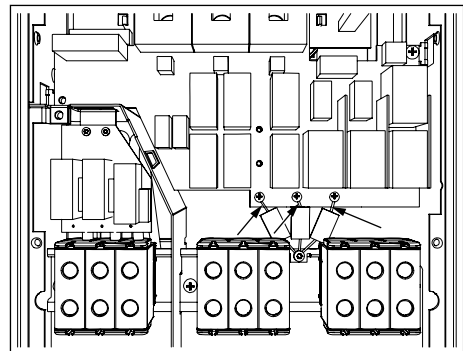



- 7 Remove the screw and the capacitor assembly.

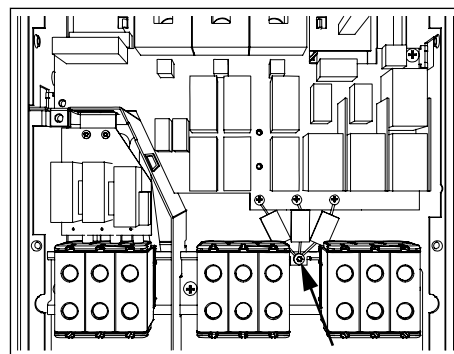

- 8 Close the cover of the AC drive. For the tightening torques of the screws, see *Table 5 The tightening torques of the cover screws*.
- 9 After the change, write "The EMC level was changed" and the date on the "product changed" label. If the label is not attached at this time, attach it on the drive near the name plate.



**NOTE!**

Only an authorized VACON® service person can change the EMC level of FR7 back to C2.

### 8.5.3 ENCLOSURE SIZES FR8 - FR11

Only a VACON® service person can change the EMC protection class of VACON® NXS or NXP, FR8-FR11.

## 8.6 INSTALLATION IN A CORNER GROUNDED NETWORK

You can use corner-grounding with the drive types (FR4 to FR9) with a rating of 3 - 300 A with a 208 - 240 V mains, and 261 - 730 A with a 380 - 500 V mains. In these conditions, you must change the EMC protection level to C4. See the instructions in chapter 9.2 VACON® NXS and NXP - *technical data*.

Do not use corner-grounding with the drive types (FR4 to FR8) with a rating of 3 - 205 A with a 380 - 500 V mains or with a 525 - 690 V mains.

Corner grounding is permitted for the FR4-9 drives (main voltage 208-240 V) up to 3000 m and for the FR9-FR11 drives (main voltage 380 - 500 V) up to 2000 m.

## 8.7 MAINTENANCE

In normal conditions, VACON® NX AC drives are maintenance-free. To make sure that the drive operates correctly and has a long life, we recommend that you do regular maintenance. Refer to the table for maintenance intervals.

**Table 53: The maintenance intervals and tasks**

Maintenance interval	Maintenance task
12 months (if the AC drive is kept in store)	Reform the capacitors (see Chapter 8.7.1 <i>Capacitor reforming</i> )
6-24 months (The interval is different in different environments.)	<ul style="list-style-type: none"> <li>• Do a check of the tightening torques of the terminals.</li> <li>• Clean the heat sink.</li> <li>• Do a check of the mains cable terminal, motor cable terminal and the control terminals.</li> <li>• Clean the cooling tunnel.</li> <li>• Make sure that the cooling fan operates correctly.</li> <li>• Make sure that there is no corrosion on the terminals, the busbars or other surfaces.</li> <li>• Do a check of the door filters, if you have a cabinet installation.</li> </ul>
5-7 years	Change the cooling fans: <ul style="list-style-type: none"> <li>• the main fan</li> <li>• the internal IP54 (UL Type 12) fan</li> <li>• the cabinet cooling fan/filter</li> </ul>
5-10 years	Change the DC bus capacitors, if the DC voltage ripple is high.

**8.7.1 CAPACITOR REFORMING**

After a long storage time, it is necessary to reform the capacitors to prevent damage to the capacitors. To make sure that the possible high leakage current through the capacitors stays in minimum, use a DC-power supply with an adjustable current limit.

- 1 Set the current limit to 300-800mA to agree with the size of the drive.
- 2 Connect the DC-power supply to the B+/B- terminals (DC+ to B+, DC- to B-) of the DC-link or directly to the capacitor terminals. In the NX AC drives with no B+/B- terminals (FR8/FR9), connect the DC-supply between 2 input phases (L1 and L2).
- 3 In drives FR8 to FR11: To make sure that the capacitors are fully charged, remove the fuses of the cooling fan. If necessary, speak to the factory to get more instructions.
- 4 Set the DC-voltage to the nominal DC-voltage level of the AC drive (1.35\*Un AC) and give the AC drive power for 1 hour, at minimum.

If the AC drive was in store for much longer than 12 months and the capacitors were not charged, speak to the factory to get instructions before you connect the power.

## **9 TECHNICAL DATA FOR VACON® NXS AND NXP**

### **9.1 AC DRIVE POWER RATINGS**

#### **9.1.1 MAINS VOLTAGE 208-240 V**

All sizes are available as IP21 (UL Type 1) or IP54 (UL Type 12).

**Table 54: The power ratings of VACON® NX AC drives in mains voltage 208-240V, 50/60 Hz, 3~**

Enclosure size	Drive type	Input current I <sub>L in</sub> [A]	Loadability					Motor shaft power			
			Low *		High *		Max current I <sub>s 2 s</sub>	230 V mains		240 V mains	
			Continuous current I <sub>L</sub> [A]	10% overload current [A]	Continuous current I <sub>H</sub> [A]	50% overload current [A]		10% overload 40°C (104°F) [kW]	50% overload 50°C (122°F) [kW]	10% overload 40°C (104°F) [hp]	50% overload 50°C (122°F) [hp]
FR4	0003*	3.7	3.7	4.1	2.4	3.6	4.8	0.55	0.37	0.75	0.5
	0004	4.8	4.8	5.3	3.7	5.6	7.4	0.75	0.55	1	0.75
	0007	6.6	6.6	7.3	4.8	7.2	9.6	1.1	0.75	1.5	1
	0008	7.8	7.8	8.6	6.6	9.9	13.2	1.5	1.1	2	1.5
	0011	11	11.0	12.1	7.8	11.7	15.6	2.2	1.5	3	2
	0012	12.5	12.5	13.8	11.0	16.5	22.0	3.0	2.2	4	3
FR5	0017	17.5	17.5	19.3	12.5	18.8	25.0	4.0	3.0	5	4
	0025	25	25.0	27.5	17.5	26.3	35.0	5.5	4.0	7.5	5
	0031	31	31.0	34.1	25.0	37.5	50.0	7.5	5.5	10	7.5
FR6	0048	48	48	52.8	31.0	46.5	62.0	11.0	7.5	15	10
	0061	61	61.0	67.1	48.0	72.0	96.0	15.0	11.0	20	15
FR7	0075	75	75.0	83.0	61.0	92.0	122.0	22.0	15.0	25	20
	0088	88	88.0	97.0	75.0	113.0	150.0	22.0	22.0	30	25
	0114	114	114.0	125.0	88.0	132.0	176.0	30.0	22.0	40	30
FR8	0140	140	140.0	154.0	105.0	158.0	210.0	37.0	30.0	50	40
	0170	170	170.0	187.0	140.0	210.0	280.0	45.0	37.0	60	50
	0205	205	205.0	226.0	170.0	255.0	340.0	55.0	45.0	75	60
FR9	0261	261	261.0	287.0	205.0	308.0	410.0	75.0	55.0	100	75
	0300	300	300.0	330.0	245.0	368.0	490.0	90.0	75.0	125	100

\*) Only available for NXP range

**NOTE!**

The currents in given ambient temperatures (in 9.2 VACON® NXS and NXP - *technical data*) are achieved only when the switching frequency is the same or smaller than the factory default.

**9.1.2 MAINS VOLTAGE 380-500 V**

All sizes are available as IP21 (UL Type 1). The sizes FR4 to FR10 are also available as IP54 (UL Type 12).

**Table 55: The power ratings of VACON® NX AC drive in mains voltage 380-500V, 50/60 Hz, 3~**

Enclosure size	Drive type	Input current I <sub>Lin</sub> [A]	Loadability					Motor shaft power			
			Low *		High *		Max current I <sub>s2</sub>	400 V mains		480 V mains	
			Continuous current I <sub>L</sub> [A]	10% overload current [A]	Continuous current I <sub>H</sub> [A]	50% overload current [A]		10% overload 40°C (104°F) [kW]	50% overload 50°C (122°F) [kW]	10% overload 40°C (104°F) [hp]	50% overload 50°C (122°F) [hp]
FR4	0003*	3.3	3.3	3.6	2.2	3.3	4.4	1.1	0.75	2	1.5
	0004	4.3	4.3	4.7	3.3	5	6.6	1.5	1.1	3	2
	0005	5.6	5.6	6.2	4.3	6.5	8.6	2.2	1.5	4	3
	0007	7.6	7.6	8.4	5.6	8.4	11.2	3	2.2	5	4
	0009	9	9	9.9	7.6	11.4	15.2	4	3	7.5	5
	0012	12	12	13.2	9	13.5	18	5.5	4	10	7.5
FR5	0016	16	16	17.6	12	18	24	7.5	5.5	13	10
	0022	23	23	25.3	16	24	32	11	7.5	20	13
	0031	31	31	34	23	35	44	15	11	25	20
FR6	0038	38	38	42	31	47	62	18.5	15	30	25
	0045	46	46	49.5	38	57	76	22	18.5	40	30
	0061	61	61	67	46	69	92	30	22	50	40
FR7	0072	72	72	79	61	92	122	37	30	60	50
	0087	87	87	96	72	108	144	45	37	75	60
	0105	105	105	116	87	131	174	55	45	90	75
FR8	0140	140	140	154	105	158	210	75	55	125	90
	0168	170	170	187	140	210	280	90	75	150	125
	0205	205	205	226	170	255	340	110	90	175	150
FR9	0261	261	261	287.1	205	308	410	132	110	200	175
FR10	0388	388	388	420	308	458	600	260	180	350	280
	0460	460	460	506	385	578	770	250	200	400	350
	0520	520	520	576	460	690	920	250	250	450	400

**Table 55: The power ratings of VACON® NX AC drive in mains voltage 380-500V, 50/60 Hz, 3~**

Enclosure size	Drive type	Input current I <sub>Lin</sub> [A]	Loadability					Motor shaft power			
			Low *		High *		Max current I <sub>s2</sub>	400 V mains		480 V mains	
			Continuous current I <sub>L</sub> [A]	10% overload current [A]	Continuous current I <sub>H</sub> [A]	50% overload current [A]		10% overload 40°C (104°F) [kW]	50% overload 50°C (122°F) [kW]	10% overload 40°C (104°F) [hp]	50% overload 50°C (122°F) [hp]
FR11	0590	590	590	649	520	780	1040	315	250	500	450
	0650	650	650	715	590	885	1180	355	315	600	500
	0730	730	730	803	650	975	1300	400	355	650	600



**NOTE!**

The currents in given ambient temperatures (in 9.2 VACON® NXS and NXP - technical data) are achieved only when the switching frequency is the same or smaller than the factory default.

The currents for FR10 to FR11 are valid at an ambient temperature of 40°C (104 °F) (except for 0520 5: currents are valid at an ambient temperature of 35°C (95 °F)).

**9.1.3 MAINS VOLTAGE 525–690 V (UL RATING 600 V)**

All sizes are available as IP21 (UL Type 1). The sizes FR4 to FR10 are also available as IP54 (UL Type 12).

**Table 56: The power ratings of VACON® NX AC drive in mains voltage 525-690 V (UL rating 600 V), 50/60 Hz, 3~**

Enclosure size	Drive type	Input current I <sub>Lin</sub> [A]	Loadability					Motor shaft power			
			Low		High		Max current I <sub>s</sub> 2s	690 V mains		575 V mains	
			Continuous current I <sub>L</sub> [A]	10% overload current [A]	Continuous current I <sub>H</sub> [A]	50% overload current [A]		10% overload 40°C / 104 °F [kW]	50% overload 50°C / 122 °F [kW]	10% overload 40°C / 104 °F [hp]	50% overload 50°C / 122 °F [hp]
FR6	0004	4.5	4.5	5.0	3.2	4.8	6.4	3.0	2.2	3	2
	0005	5.5	5.5	6.1	4.5	6.8	9.0	4.0	3.0	4	3
	0007	7.5	7.5	8.3	5.5	8.3	11.0	5.5	4.0	5	4
	0010	10.0	10.0	11.0	7.5	11.3	15.0	7.5	5.5	7.5	5
	0013	13.5	13.5	14.9	10.0	15.0	20.0	11.0	7.5	10	7.5
	0018	18.0	18	19.8	13.5	20.3	27.0	15.0	11.0	15	10
	0022	22.0	22.0	24.2	18.0	27.0	36.0	18.5	15.0	20	15
	0027	27.0	27.0	29.7	22.0	33.0	44.0	22.0	18.5	25	20
	0034	34.0	34.0	37.0	27.0	41.0	54.0	30.0	22.0	30	25
FR7	0041	41.0	41.0	45.0	34.0	51.0	68.0	37.5	30.0	40	30
	0052	52.0	52.0	57.0	41.0	62.0	82.0	45.0	37.5	50	40
FR8	0062	62.0	62.0	68.0	52.0	78.0	104.0	55.0	45.0	60	50
	0080	80.0	80.0	88.0	62.0	93.0	124.0	75.0	55.0	75	60
	0100	100.0	100.0	110.0	80.0	120.0	160.0	90.0	75.0	100	75
FR9	0125	125.0	125.0	138.0	100.0	150.0	200.0	110.0	90.0	125	100
	0144	144.0	144.0	158.0	125.0	188.0	250.0	132.0	110.0	150	125
	0170	170.0	170.0	187.0	144.0	216.0	288.0	160.0	132.0	150	150
	0208	208.0	208.0	229.0	170.0	255.0	340.0	200.0	160.0	200	150
FR10	0261	261.0	261.0	287.0	208.0	312.0	416.0	250.0	200.0	250	200
	0325	325.0	325.0	358.0	261.0	392.0	522.0	315.0	250.0	350	250
	0385	385.0	385.0	424.0	325.0	488.0	650.0	355.0	315.0	400	350
	0416	416.0	416.0	358.0	325.0	488.0	650.0	400.0	315.0	450	350



**Table 56: The power ratings of VACON® NX AC drive in mains voltage 525-690 V (UL rating 600 V), 50/60 Hz, 3~**

Enclosure size	Drive type	Input current I <sub>L in</sub> [A]	Loadability				Motor shaft power				
			Low		High		Max current I <sub>s 2 s</sub>	690 V mains		575 V mains	
			Continuous current I <sub>L</sub> [A]	10% overload current [A]	Continuous current I <sub>H</sub> [A]	50% overload current [A]		10% overload 40°C / 104 °F [kW]	50% overload 50°C / 122 °F [kW]	10% overload 40°C / 104 °F [hp]	50% overload 50°C / 122 °F [hp]
FR11	0460	460.0	460.0	506.0	385.0	578.0	770.0	450.0	355.0	500	450
	0502	502.0	502.0	552.0	460.0	690.0	920.0	500.0	450.0	550	500
	0590	590.0	590.0	649.0	502.0	753.0	1004.0	560.0	500.0	600	550



**NOTE!**

The currents in given ambient temperatures (in 9.2 VACON® NXS and NXP - technical data) are achieved only when the switching frequency is the same or smaller than the factory default.

The currents for FR10 to FR11 are valid at an ambient temperature of 40°C (104 °F) (except for 0416 6 and 0590 6: currents are valid at an ambient temperature of 35°C (95 °F)).

**9.1.4 OVERLOAD CAPABILITY**

The **low overload** means that if 110% of the continuous current (I<sub>L</sub>) is required for 1 minute every 10 minutes, the remaining 9 minutes must be approximately 98% of I<sub>L</sub> or less. This is to make sure that the output current is not more than I<sub>L</sub> during the duty cycle.

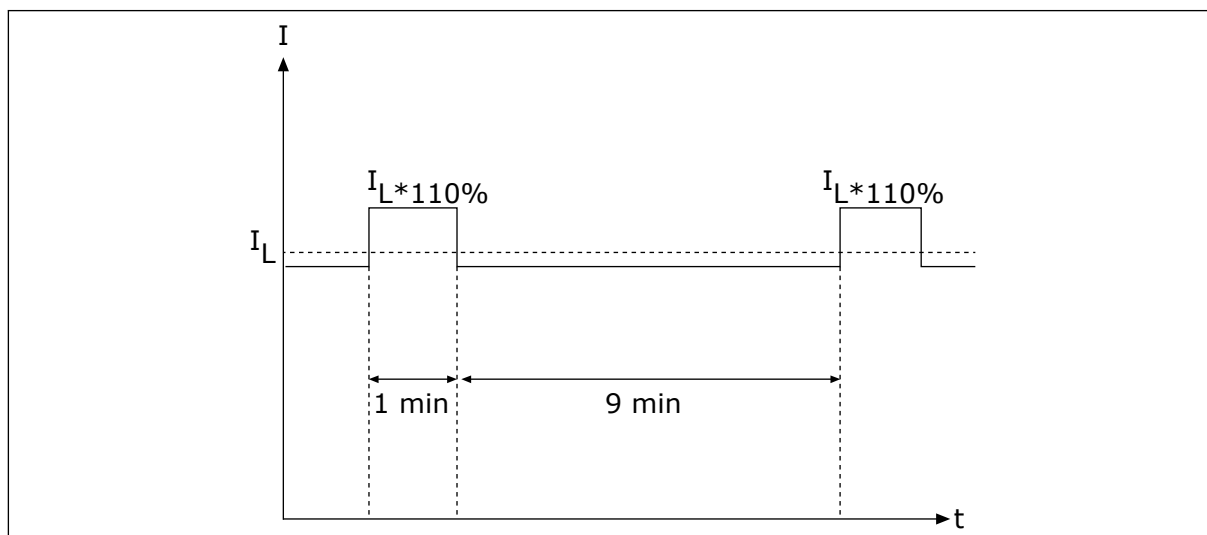

Fig. 36: Low overload

The **high overload** means that if 150% of the continuous current (I<sub>H</sub>) is required for 1 minute every 10 minutes, the remaining 9 minutes must be approximately 92% of I<sub>H</sub> or less. This is to make sure that the output current is not more than I<sub>H</sub> during the duty cycle.

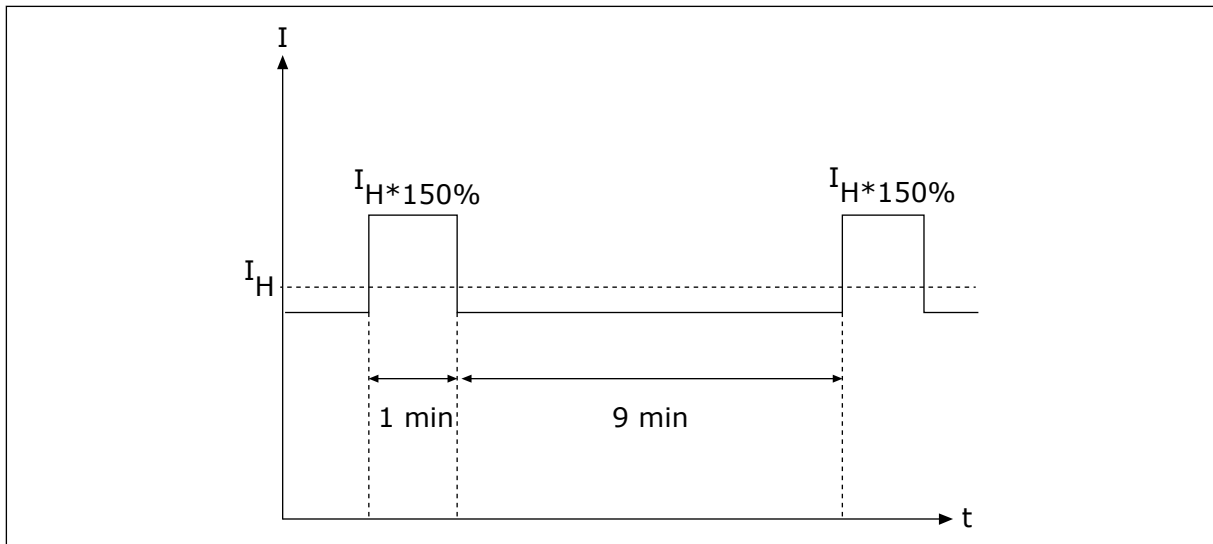

Fig. 37: High overload

For more information, refer to the standard IEC61800-2 (IEC:1998).

#### 9.1.5 BRAKE RESISTOR RATINGS

For more information, see VACON® NX Brake Resistors User Manual.

**Table 57: Brake resistor ratings for VACON® NX AC drives , mains voltage 208-240V**

Mains voltage 208-240 V, 50/60 Hz, 3~			
Enclosure size	Drive type	The minimum brake resistance [ $\Omega$ ]	Brake power* @405 VDC [kW]
FR4	0003	30	0.55
	0004	30	0.75
	0007	30	1.1
	0008	30	1.5
	0011	30	2.2
	0012	30	3.0
FR5	0017	30	4.0
	0025	30	5.5
	0031	20	7.5
FR6	0048	10	11.0
	0061	10	15.0
FR7	0075	3.3	22.0
	0088	3.3	22.0
	0114	3.3	30.0
FR8	0140	1.4	37.0
	0170	1.4	45.0
	0205	1.4	55.0
FR9	0261	1.4	75.0
	0300	1.4	90.0

\*) When you use recommended resistor types.

**Table 58: Brake resistor ratings for VACON® NX AC drives, mains voltage 380-500V**

Mains voltage 380-500 V, 50/60 Hz, 3~			
Enclosure size	Drive type	The minimum brake resistance [ $\Omega$ ]	Brake power* @845 VDC [kW]
FR4	0003	63	1.5
	0004	63	2.2
	0005	63	3.0
	0007	63	4.0
	0009	63	5.5
	0012	63	7.5
FR5	0016	63	11.0
	0022	63	11.3
	0031	42	17.0
FR6	0038	19	22.0
	0045	19	30.0
	0061	14	37.0
FR7	0072	6.5	45.0
	0087	6.5	55.0
	0105	6.5	75.0
FR8	0140	3.3	90.0
	0168	3.3	110.0
	0205	3.3	132.0
FR9	0261	2.5	160.0
	0300	2.5	200.0
FR10	0385	1.4	250.0
	0460	1.4	315.0
	0520	1.4	355.0
FR11	0590	0.9	400.0
	0650	0.9	450.0
	0730	0.9	500.0

\*) When you use recommended resistor types.

**Table 59: Brake resistor ratings for VACON® NX AC drives, mains voltage 525-690V**

Mains voltage 525-690 V, 50/60 Hz, 3~			
Enclosure size	Drive type	The minimum brake resistance [Ω]	Brake power* @1166 VDC [kW]
FR6	0004	100	3.0
	0005	100	4.0
	0007	100	5.5
	0010	100	7.5
	0013	100	11.0
	0018	30	15.0
	0022	30	18.5
	0027	30	22.0
	0034	30	30.0
FR7	0041	18	37.5
	0052	18	45.0
FR8	0062	9	55.0
	0080	9	75.0
	0100	9	90.0
FR9	0125	6.7	110.0
	0144	6.7	132.0
	0170	6.7	160.0
	0208	6.7	194.2
FR10	0261	2.5	250.0
	0325	2.5	315.0
	0385	2.5	355.0
	0416	2.5	400.0
FR11	0460	1.7	450.0
	0502	1.7	500.0
	0590	1.7	560.0

\*) When you use recommended resistor types.

## 9.2 VACON® NXS AND NXP - TECHNICAL DATA

**Table 60: The technical data of the VACON® NXS and NXP AC drive**

Technical item or function		Technical data
Mains connection	Input voltage $U_{in}$	208-240 V, 380-500 V, 525-690 V, UL rating up to 600 V, -10%...+10%
	Input frequency	45-66 Hz
	Connection to mains	Once per minute or less
	Starting delay	2 s (FR4 to FR8), 5 s (FR9)
	Network imbalance	Max. $\pm 3\%$ of the nominal voltage
	Mains	Mains types: TN, TT, and IT Short circuit current: the maximum short circuit current must be < 100 kA.
Motor connection	Output voltage	0- $U_{in}$
	Continuous output current	IL: Ambient temperature max. +40 °C (104 °F) overload 1.1 x IL (1 min/10 min) IH: Ambient temperature max. +50 °C (122 °F) overload 1.5 x IH (1 min/10 min) For 50 – 55 °C ambient temperatures use derating factor $I_H \cdot 2.5\% / ^\circ C$ .
	Starting current	IS for 2 s each 20 s. After 2 s the current controller makes it go down to 150% IH.
	Output frequency	0-320 Hz (standard NXP and NXS); 7200 Hz (special NXP with special software)
	Frequency resolution	0.01 Hz (NXS); Application dependent (NXP)

**Table 60: The technical data of the VACON® NXS and NXP AC drive**

Technical item or function		Technical data
Control qualities	Control method	Frequency control U/f, Open Loop Sensorless Vector Control, Closed Loop Vector Control (NXP only)
	Switching frequency (see parameter P2.6.9)	208-240 V and 380-500 V, up to 0061: 1-16 kHz Default: 6 kHz 208-240 V, 0075 and larger: 1-10 kHz Default: 3.6 kHz 380-500 V, 0072 and larger: 1-6 kHz Default: 3.6 kHz 525-690 V: 1-6 kHz Default: 1.5 kHz
	<b>Frequency reference</b> Analogue input Panel reference	Resolution 0.1% (NXP: 12-bit), accuracy $\pm 1\%$ Resolution 0.01 Hz
	Field weakening point	8-320 Hz
	Acceleration time	0.1-3000 s
	Deceleration time	0.1-3000 s
	Braking torque	DC brake: 30% * TN (without the brake option)



**Table 60: The technical data of the VACON® NXS and NXP AC drive**

Technical item or function	Technical data	
Ambient conditions	<p><b>Ambient operating temperature</b></p> <p><b>FR4-FR9</b>                      IL current: -10°C (-14 °F) (no frost)...+40 °C (104 °F)                      IH current: -10°C (-14 °F) (no frost)...+50 °C (122 °F)</p> <p><b>FR10-FR11 (IP21/UL Type 1)</b>                      IH/IL : -10°C (-14 °F) (no frost)...+40°C (104 °F) (except 525-690 V, 0461 and 0590: -10°C (-14 °F) (no frost)...+35°C (95 °F))</p> <p><b>FR10 (IP54/UL Type 12)</b>                      IH/IL : -10°C (-14 °F) (no frost)...+40°C (104 °F) (except 380-500 V, 0520 and 525-690 V, 0416: -10°C (-14 °F) (no frost)...+35°C (95 °F))</p> <p>For higher ambient temperatures see Motor connection – Continuous output current in this table.</p>	
	<p><b>Storage temperature</b></p> <p>-40 °C (-104 °F)...+70 °C (158 °F)</p>	
	<p><b>Relative humidity</b></p> <p>0-95% RH, non-condensing, non-corrosive, no dripping water</p>	
	<p><b>Air quality:</b></p> <ul style="list-style-type: none"> <li>• chemical vapours</li> <li>• mechanical particles</li> </ul>	<p>Designed according to</p> <ul style="list-style-type: none"> <li>• IEC 60721-3-3, AC drive in operation, class 3C2</li> <li>• IEC 721-3-3, AC drive in operation, class 3S2</li> </ul>
	<p><b>Altitude</b></p>	<p>100% load capacity (no derating) up to 1000 m (3281 ft)                      1% derating for each 100 m (328 ft) above 1000 m (3281 ft)</p> <p>Maximum altitudes:</p> <ul style="list-style-type: none"> <li>• FR4-8 208-240 V: 3000 m (9843 ft) (TN, TT and IT systems)</li> <li>• FR9-11 208-240 V: 4000 m (13123 ft) (TN, TT and IT systems)</li> <li>• 208-240 V: 3000 m (9843 ft) (corner-grounded network *)</li> <li>• FR4-8 380-500 V: 3000 m (9843 ft) (TN, TT and IT systems)</li> <li>• FR9-11 380-500 V: 4000 m (13123 ft) (TN, TT and IT systems)</li> <li>• 380-500 V: 2000 m (6562 ft) (corner-grounded network **)</li> <li>• 525-690 V: 2000 m (6562 ft) (TN, TT and IT systems, no corner-grounding)</li> </ul> <p>* Corner-grounded network is permitted for FR4-FR9 (Main voltage 208-240V) up to 3000 m (See chapter 8.6 <i>Installation in a corner grounded network</i>)</p> <p>** Corner-grounded network is permitted for FR9 – FR11 (Main voltage 380 – 500 V) up to 2000 m (See chapter 8.6 <i>Installation in a corner grounded network</i>)</p>

**Table 60: The technical data of the VACON® NXS and NXP AC drive**

Technical item or function		Technical data
Ambient conditions	<b>Vibration</b> IEC/EN 60068-2-6 IEC/EN 61800-5-1	5-150 Hz Displacement amplitude 1 mm (peak) at 5-15.8 Hz (FR4-FR9) Maximum acceleration amplitude 1 G at 15.8-150 Hz (FR4-FR9) Displacement amplitude 0.25 mm (peak) at 5-31 Hz (FR10-FR11) Maximum acceleration amplitude 0.25G at 31-150 Hz (FR10-FR11)
	<b>Shock</b> IEC/EN 60068-2-27	UPS Drop Test (for applicable UPS weights) Storage and shipping: maximum 15 G, 11 ms (in package)
	Enclosure class	IP21 (UL Type 1) standard in entire kW/HP range IP54 (UL Type 12) option in FR4 to FR10  <b>NOTE!</b> For IP54 (UL Type 12), a keypad is necessary.
	Pollution degree	PD2
EMC (at default settings)	Immunity	Low frequency: Complies with IEC 61000-3-12, when $R_{sce} > 120$ and $I_n < 75$ A High frequency: Complies with IEC/EN 61800-3 + A1, 1st and 2nd environment
	Emissions	Depend on EMC level. See Chapters 1 Approvals and 3 Receiving the delivery.
Noise level	Average noise level (cooling fan) in dB(A)	The sound pressure depends on the cooling fan speed, which is controlled in accordance with the drive temperature. FR4: 44 FR5: 49 FR6-FR7: 57 FR8: 58 FR9-FR11: 76
Safety standards		IEC/EN 61800-5-1, UL 508C, CSA C22.2 No.287
Approvals		CE, cULus, RCM, KC, EAC, UA. (See the nameplate of the drive for more approvals.) Marine approvals: LR, BV, DNV, GL, ABS, RMRS, CCS, KR.

**Table 60: The technical data of the VACON® NXS and NXP AC drive**

Technical item or function	Technical data	
Control connections (apply to boards OPTA1, OPTA2 and OPTA3)	Analogue input voltage	0...+10 V, $R_i = 200\text{ k}\Omega$ , (-10 V...+10 V joystick control) Resolution 0.1% (NXP: 12-bit, NXS: 10-bit), accuracy $\pm 1\%$
	Analogue input current	0(4)-20 mA, $R_i = 250\ \Omega$ differential
	Digital inputs (6)	Positive or negative logic; 18-30 VDC
	Auxiliary voltage	+24 V, $\pm 10\%$ , max volt. ripple < 100 mVrms; max. 250 mA Dimensioning: max. 1000 mA/control box (power backup)
	Output reference voltage	+10 V, +3%, max. load 10 mA
	Analogue output	0(4)-20 mA, $R_L$ max. 500 $\Omega$ ; Resolution 10 bit; Accuracy $\pm 2\%$
	Digital outputs	Open collector output, 50 mA/48 V
	Relay outputs	2 programmable change-over relay outputs Switching capacity (resistive): 24 VDC/8 A, 250 VAC/8 A, 125 VDC/0.4 A Min.switching load: 5 V/10 mA

**Table 60: The technical data of the VACON® NXS and NXP AC drive**

Technical item or function	Technical data	
Protections	Overvoltage trip limit	The 240-volt drives: 437 VDC The 500-volt drives: 911 VDC The 690-volt drives: 1200 VDC
	Undervoltage trip limit	Mains voltage 240 V: 183 VDC Mains voltage 500 V: 333 VDC Mains voltage 690 V: 461 VDC
	Earth fault protection	If there is an earth fault in the motor or motor cable, only the AC drive is protected.
	Mains supervision	Trips if some of the input phases is missing
	Motor phase supervision	Trips if some of the output phases is missing
	Overcurrent protection	Yes
	Unit overtemperature protection	Yes
	Motor overload protection	Yes. * The motor overload protection activates at 110% of the full load current.
	Motor stall protection	Yes
	Motor underload protection	Yes
Short-circuit protection of +24 V and +10 V reference voltages	Yes	

\* = For the motor thermal memory and the memory retention function to obey the UL 508C requirements, you must use the system software version NXS00001V175, NXS00002V177 or NXP00002V186 or a newer version. If you use an older system software version, you must install a motor overtemperature protection to comply with the UL regulations.

### 9.3 THE COMPLIANCE WITH THE PRODUCT STANDARD IEC/EN 61800-3 + A1

The product standard IEC/EN 61800-3 + A1 has 5 categories. The VACON® AC drives are divided into 5 classes that have equivalents in the standard.

**Table 61: The equivalents of the product standard IEC/EN 61800-3 + A1 in VACON® classes**

EMC category in the product standard IEC/EN 61800-3 + A1	EMC class in VACON® AC drives	Note
C1	C	
C2	H	
C3	L	
C4	T	Complies with the standard when used in IT networks
No EMC emission protection.	N	An external EMC filter is necessary.

The category changes when these properties in the AC drive change:

- the level of electromagnetic disturbances
- the requirements of a power system network
- the installation environment (see 9.3.1 *Environment definitions in product standard IEC/EN 61800-3 + A1*).

The Type designation code tells which category requirement your AC drive complies with.

All VACON® NX AC drives comply with all EMC immunity requirements (standard IEC/EN 61800-3 + A1).

### CATEGORY C1

Available for 380-500 V, FR4 to FR6, IP54 (UL Type 12).

The AC drives in category C1 have the best EMC protection. These AC drives have the nominal voltage of less than 1000 V. They are used in the 1st environment.



#### NOTE!

If the enclosure class of the AC drive is IP21 (UL Type 1), only the conducted emissions are in the requirements of category C1.

### CATEGORY C2

Available for 380-500 V, FR4 to FR9 and 208-240 V, FR4 to FR9.

The category C2 includes AC drives in fixed installations. These AC drives have the nominal voltage of less than 1000 V. The category C2 AC drives can be used in the 1st and the 2nd environment.

### CATEGORY C3

Available for IP21 (UL Type 1) and IP54 (UL Type 12) in 380-500 V FR10 and larger, 525-690 V FR6 and larger.

The category C3 includes AC drives that have the nominal voltage of less than 1000 V. These AC drives are used in the 2nd environment only.

**CATEGORY C4**

Available for: All products.

These AC drives comply with the standard IEC/EN 61800-3 + A1 if they are used in IT systems. In IT systems, the networks are isolated from ground, or connected to ground through high impedance to decrease the leakage current.



**NOTE!**

If the AC drives are used with other supplies, they do not comply with the EMC requirements.

To change the EMC protection category of your VACON® NX AC drive from C2 or C3 to C4, see the instructions in Chapter 8.5 *Installation in an IT system*.

**NO EMC EMISSION PROTECTION**

In IP00.

The AC drives of this category do not give EMC emission protection. These drives are installed in enclosures.



**NOTE!**

An external EMC filter is usually necessary to comply with the EMC emission requirements.



**WARNING!**

In a domestic environment this product can cause radio interference. If necessary, do the sufficient steps.

**9.3.1 ENVIRONMENT DEFINITIONS IN PRODUCT STANDARD IEC/EN 61800-3 + A1**

Environment	Description	Examples
First environment	Environment that includes domestic premises. It also includes establishments directly connected without intermediate transformers to a low-voltage power supply network which supplies buildings used for domestic purposes.	Houses, apartments, commercial premises or offices in a residential building are examples of first environment locations.
Second environment	Environment that includes all establishments other than those directly connected to a low-voltage power supply network that supplies buildings used for domestic purposes.	Industrial areas, technical areas of a building supplied from a dedicated transformer are examples of second environment locations.

## 10 FAULT TRACING

When the control diagnostics of the AC drive find an unusual condition in the operation of the drive, the drive shows this information:

- This information shows on the display (see 7.7 *Using the Active faults menu (M4)*):
  - the location indication F1
  - the fault code (see Chapter 10.2 *Fault codes*)
  - a short description of the fault
  - the fault type symbol (see Table 62)
  - the FAULT or ALARM symbol
- The red LED on the keypad starts to blink (only when a fault shows).

If many faults show at the same time, you can examine the list of active faults with the Browser buttons.

In the NX AC drives, there are 4 different types of faults.

**Table 62: Fault types**

Fault type symbol	Description
A (Alarm)	The type A fault (Alarm) tells you about unusual operation on the drive. It does not stop the drive. The 'A fault' stays in the display for about 30 seconds.
F (Fault)	The type 'F fault' stops the drive. To start the drive again, you must find a solution to the problem.
AR (Fault Autoreset)	The type 'AR fault' stops the drive. The fault is reset automatically and the drive tries to start the motor again. If it cannot the start the motor again, a fault trip (FT, see below) shows.
FT (Fault Trip)	If the drive cannot start the motor after an AR fault, an FT fault shows. The type 'FT fault' stops the AC drive.

The fault stays active until it is reset, see Chapter 10.1 *Resetting a fault*. The memory of active faults can keep the maximum of 10 faults in the order in which they were shown.

Reset the fault with the Reset button on the keypad, or through the control terminal, fieldbus or the PC tool. The faults stay in the Fault history where you can go and examine them. See the different fault codes in Chapter 10.2 *Fault codes*.

Before you ask help from the distributor or the factory because of unusual operation, prepare some data. Write down all the texts on the display, the fault code, the source information, the Active Faults list and the Fault History.

### 10.1 RESETTING A FAULT

- 1 Remove the external Start signal before you reset the fault to prevent that the drive starts again without a note.
- 2 You have 2 options to reset a fault:

- Push the Reset button on the keypad for 2 seconds.
- Use a reset signal from the I/O terminal or fieldbus.

The display goes back to the same state it was before the fault.



## 10.2 FAULT CODES

Fault code	Fault	Subcode in T.14	Possible cause	How to correct the fault
1	Overcurrent	S1 = Hardware trip	There is too high a current (>4*I <sub>H</sub> ) in the motor cable. Its cause can be 1 of these. <ul style="list-style-type: none"> <li>• a sudden heavy load increase</li> <li>• a short circuit in the motor cables</li> <li>• the motor is not the correct type</li> </ul>	Do a check of the loading. Do a check of the motor. Do a check of the cables and connections. Make an identification run.
		S2 = Reserved		
		S3 = Current controller supervision		
		S4 = User configured overcurrent limit exceeded		
2	Overvoltage	S1 = Hardware trip	The DC-link voltage is higher than the limits. <ul style="list-style-type: none"> <li>• too short a deceleration time</li> <li>• high overvoltage spikes in the supply</li> <li>• Start/Stop sequence too fast</li> </ul>	Set the deceleration time longer. Use the brake chopper or the brake resistor. They are available as options. Activate the overvoltage controller. Do a check of the input voltage.
		S2 = Overvoltage control supervision		
3*	Earth fault		The measurement of current tells that the sum of the motor phase current is not zero. <ul style="list-style-type: none"> <li>• an insulation malfunction in the cables or the motor</li> </ul>	Do a check of the motor cables and the motor.
5	Charging switch		The charging switch is open, when the START command is given. <ul style="list-style-type: none"> <li>• operation malfunction</li> <li>• defective component</li> </ul>	Reset the fault and start the drive again. If the fault shows again, ask instructions from the distributor near to you.
6	Emergency stop		Stop signal has been given from the option board.	Do a check of the emergency stop circuit.

Fault code	Fault	Subcode in T.14	Possible cause	How to correct the fault
7	Saturation trip		<ul style="list-style-type: none"> <li>defective component</li> <li>brake resistor short-circuit or overload</li> </ul>	This fault cannot be reset from the control panel. Switch off the power. <b>DO NOT RESTART THE DRIVE or CONNECT THE POWER!</b> Ask instructions from the factory. If this fault shows at the same time with Fault 1, do a check of the motor cable and the motor.
8	System fault	S1 = Reserved S2 = Reserved S3 = Reserved S4 = Reserved S5 = Reserved S6 = Reserved S7 = Charging switch S8 = No power to driver card S9 = Power unit communication (TX) S10 = Power unit communication (Trip) S11 = Power unit comm. (Measurement)	<ul style="list-style-type: none"> <li>operation malfunction</li> <li>defective component</li> </ul>	Reset the fault and start the drive again. If the fault shows again, ask instructions from the distributor near to you.

Fault code	Fault	Subcode in T.14	Possible cause	How to correct the fault
9 *	Undervoltage	S1 = DC-link too low during run S2 = No data from power unit S3 = Undervoltage control supervision	The DC-link voltage is lower than the limits.  • too low a supply voltage • AC drive internal fault • a defective input fuse • the external charge switch is not closed	If there is a temporary supply voltage break, reset the fault and start the drive again. Do a check of the supply voltage. If the supply voltage is sufficient, there is an internal fault. Ask instructions from the distributor near to you.
10 *	Input line supervision		The input line phase is missing.	Do a check of the supply voltage, the fuses and supply cable.
11 *	Output phase supervision		The measurement of current tells that there is no current in 1 motor phase.	Do a check of the motor cable and the motor.
12	Brake chopper supervision		There is no brake resistor. The brake resistor is broken. A defective brake chopper.	Do a check of the brake resistor and the cabling. If they are in good condition, there is a fault in the resistor or the chopper. Ask instructions from the distributor near to you.
13	Frequency converter undertemperature		Too low a temperature in the heatsink of the power unit or in the power board. The heatsink temperature is below -10 °C (14 °F).	
14	Frequency converter overtemperature		Heatsink temperature is over 90 °C (194 °F) (or 77 °C (170.6 °F), NX_6, FR6). Overtemperature alarm is issued when the heatsink temperature goes over 85 °C (185 °F) (72 °C (161.6 °F)).	Do a check of the actual amount and flow of cooling air. Examine the heatsink for dust. Do a check of the ambient temperature. Make sure that the switching frequency is not too high in relation to the ambient temperature and the motor load.
15 *	Motor stalled		The motor stalled.	Do a check of the motor and the load.
16 *	Motor overtemperature		There is too heavy a load on the motor.	Decrease the motor load. If there is no motor overload, do a check of the temperature model parameters.
17 *	Motor underload		Motor underload protection has tripped.	Do a check of the load.

Fault code	Fault	Subcode in T.14	Possible cause	How to correct the fault
18 **	Unbalance	S1 = Current unbalance	Unbalance between power modules in paralleled power units.	If the fault occurs again, ask instructions from the distributor near to you.
		S2 = DC voltage unbalance		
22	EEPROM checksum fault		Parameter save fault. <ul style="list-style-type: none"> <li>operation malfunction</li> <li>defective component</li> </ul>	If the fault occurs again, ask instructions from the distributor near to you.
24 **	Counter fault		Values displayed on counters are incorrect	
25	Microprocessor watchdog fault		<ul style="list-style-type: none"> <li>operation malfunction</li> <li>defective component</li> </ul>	Reset the fault and start the drive again. If the fault shows again, ask instructions from the distributor near to you.
26	Start-up prevented		Start-up of the drive has been prevented. Run request in ON when new application is downloaded to the drive.	Cancel prevention of start-up if this can be done safely. Remove Run request
29 *	Thermistor fault		The thermistor input of option board has detected increase of the motor temperature.	Do a check of the motor cooling and loading. Do a check of the thermistor connection. (If thermistor input of the option board is not in use it has to be short circuited).
30	Safe disable		The input on OPTAF board has opened,	Cancel Safe Disable if this can be done safely.
31	IGBT temperature (hardware)		IGBT Inverter Bridge over-temperature protection has detected too high a short term overload current	Do a check of the loading. Do a check of the motor size. Make an identification run.
32	Fan cooling		Cooling fan of the AC drive does not start, when ON command is give.	Ask instructions from the distributor near to you.
34	CAN bus communication		Sent message not acknowledged.	Make sure that there is another device on the bus with the same configuration.

Fault code	Fault	Subcode in T.14	Possible cause	How to correct the fault
35	Application		Problem in application software.	Ask instructions from the distributor near to you. If you are an application programmer, do a check of the application program.
36	Control unit		NXS Control Unit can not control NXP Power Unit and vice versa	Change the control unit.
37 **	Device changed (same type)		The option board was replaced by a new one that you have used before in the same slot. The parameters are available in the drive.	Reset the fault. The device is ready for use. The drive starts to use the old parameter settings.
38 **	Device added (same type)		The option board was added. You have used the same option board before in the same slot. The parameters are available in the drive.	Reset the fault. The device is ready for use. The drive starts to use the old parameter settings.
39 **	Device removed		An option board was removed from the slot.	The device is not available. Reset the fault.
40	Device unknown	S1 = Unknown device	An unknown device was connected (the power unit/option board)	Ask instructions from the distributor near to you.
		S2 = Power1not same type as Power2		
41	IGBT temperature		IGBT Inverter Bridge over-temperature protection has detected too high a short term overload current.	Do a check of the loading. Do a check of the motor size. Make an identification run.
42	Brake resistor overtemperature		Brake resistor overtemperature protection has detected too heavy braking.	Set the deceleration time longer. Use external brake resistor.

Fault code	Fault	Subcode in T.14	Possible cause	How to correct the fault
43	Encoder fault	1 = Encoder 1 channel A is missing	Problem detected in encoder signals.	Do a check of the encoder connections. Do a check of the encoder board. Do a check of the encoder frequency in the open loop.
		2 = Encoder 1 channel B is missing		
		3 = Both encoder 1 channels are missing		
		4 = Encoder reversed		
		5 = Encoder board missing		
44 **	Device changed (different type)		Option board or power unit changed. New device of different type or different power rating.	Reset. Set the option board parameters again if option board was changed. Set AC drive parameters again if power unit was changed.
45 **	Device added (different type)		Option board of different type added.	Reset. Set the power unit parameters again.
49	Division by zero in application		Division by zero has occurred in application program.	If the fault shows again while the AC drive is in run state, ask instructions from the distributor near to you. If you are an application programmer, do a check of the application program.
50 *	Analogue input lin < 4mA (sel. signal range 4 to 20 mA)		Current at the analogue input is < 4mA. control cable is broken or loose signal source has failed.	Do a check of the current loop circuitry.
51	External fault		Digital input fault.	Remove fault situation on external device.
52	Keypad communication fault		The connection between the control panel (or NCDrive) and the drive is defective.	Do a check of the control panel connection and the control panel cable.

Fault code	Fault	Subcode in T.14	Possible cause	How to correct the fault
53	Fieldbus fault		The data connection between the fieldbus master and the fieldbus board is defective.	Do a check of the installation and fieldbus master. If the installation is correct, ask instructions from the distributor near to you.
54	Slot fault		Defective option board or slot	Do a check of the board and slot. Ask instructions from the distributor near to you.
56	Over Temp.		Temperature exceeded set limit. Sensor disconnected. Short circuit.	Find the cause of temperature rise.
57 **	Identification		Identification run has failed.	Run command was removed before completion of identification run. The motor is not connected to the AC drive. There is load on motor shaft.
58 *	Brake		Actual status of the brake is different from the control signal.	Do a check of the mechanical brake state and connections.
59	Follower communication		SystemBus or CAN communication is broken between Master and Follower.	Do a check of the option board parameters. Do a check of the optical fibre cable or CAN cable.
60	Cooling		Coolant circulation on liquid-cooled drive has failed.	Do a check of the reason for the failure on the external system.
61	Speed error		Motor speed is unequal to reference.	Do a check of the encoder connection. PMS motor has exceeded the pull out torque.
62	Run disable		Run enable signal is low.	Do a check of the reason for the Run enable signal.
63 **	Emergency stop		Command for emergency stop received from digital input or fieldbus.	New run command is accepted after reset.
64 **	Input switch open		Drive input switch is open.	Do a check of the main power switch of the drive.
65	Over Temp.		Temperature exceeded set limit. Sensor disconnected. Short circuit.	Find the cause of temperature rise.
70 *	Active filter fault		Fault triggered by dig. input (see param. P2.2.7.33).	Remove fault situation on active filter

Fault code	Fault	Subcode in T.14	Possible cause	How to correct the fault
74	Follower fault		When using normal Master Follower function this fault code is given if one or more follower drives trip to fault.	

\* = You can set different responses in the application for these faults. See parameter group Protections.

\*\* = A faults (alarms) only.



# 11 APPENDIX 1

## 11.1 POWER LOSSES FOR 380-500 V

If you want to increase the switching frequency of the drive (for example, to decrease the level of the motor noise), the power losses and cooling requirements change as the figures below show.

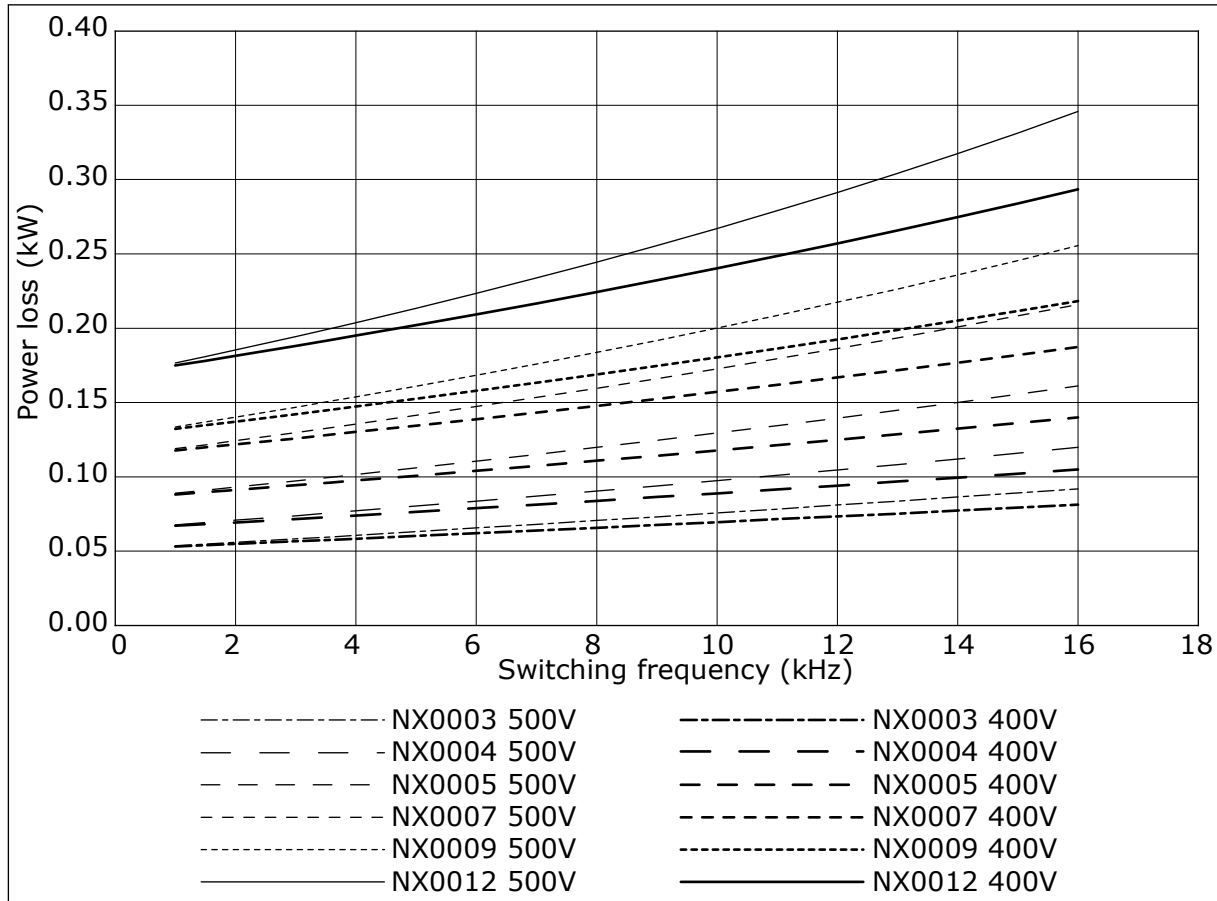

Fig. 38: Power loss as function of switching frequency; NXS or NXP 0003-0012

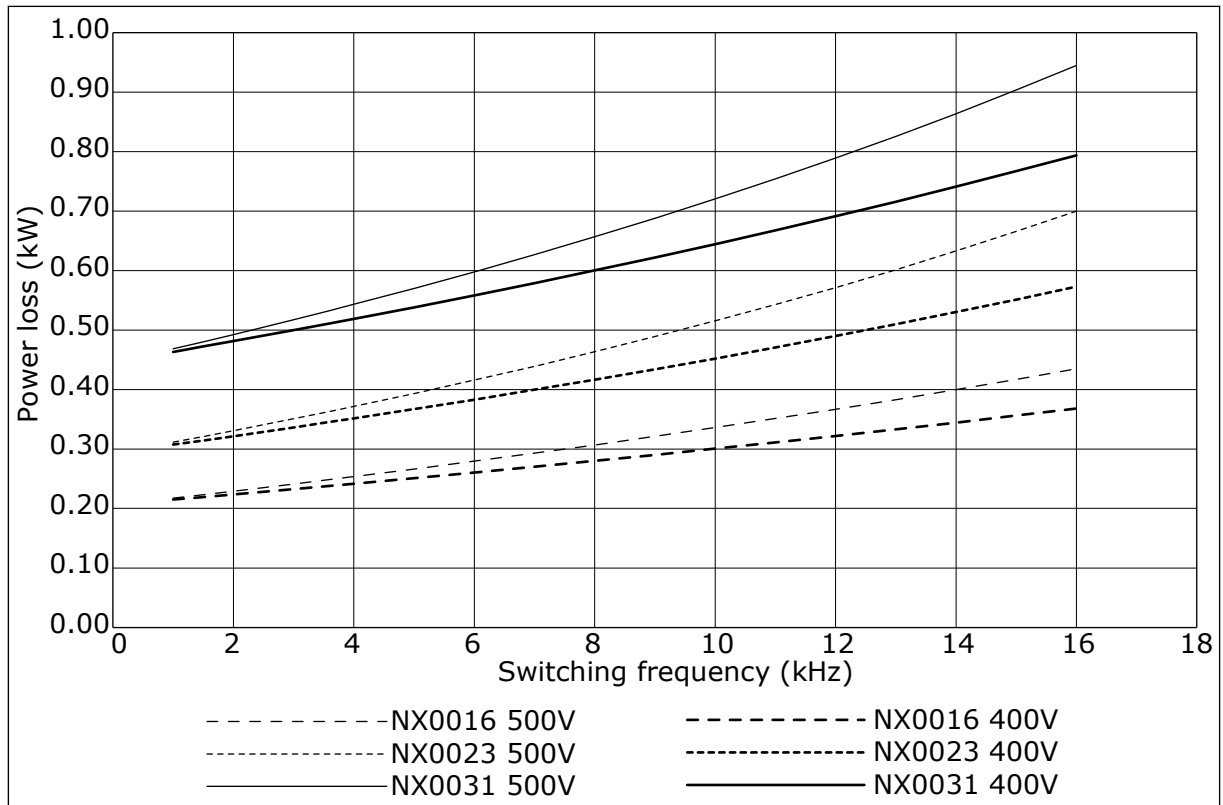

Fig. 39: Power loss as function of switching frequency; NXS or NXP 0016-0031

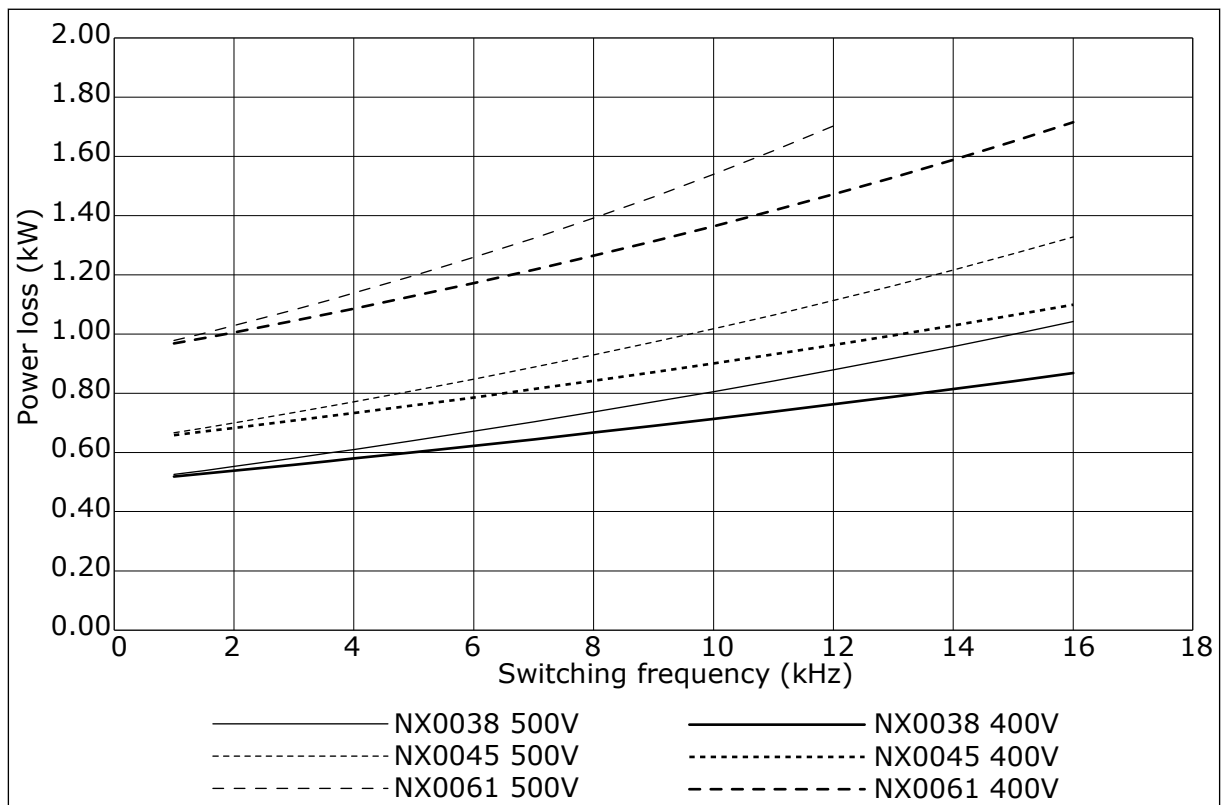

Fig. 40: Power loss as function of switching frequency; NXS or NXP 0038-0061

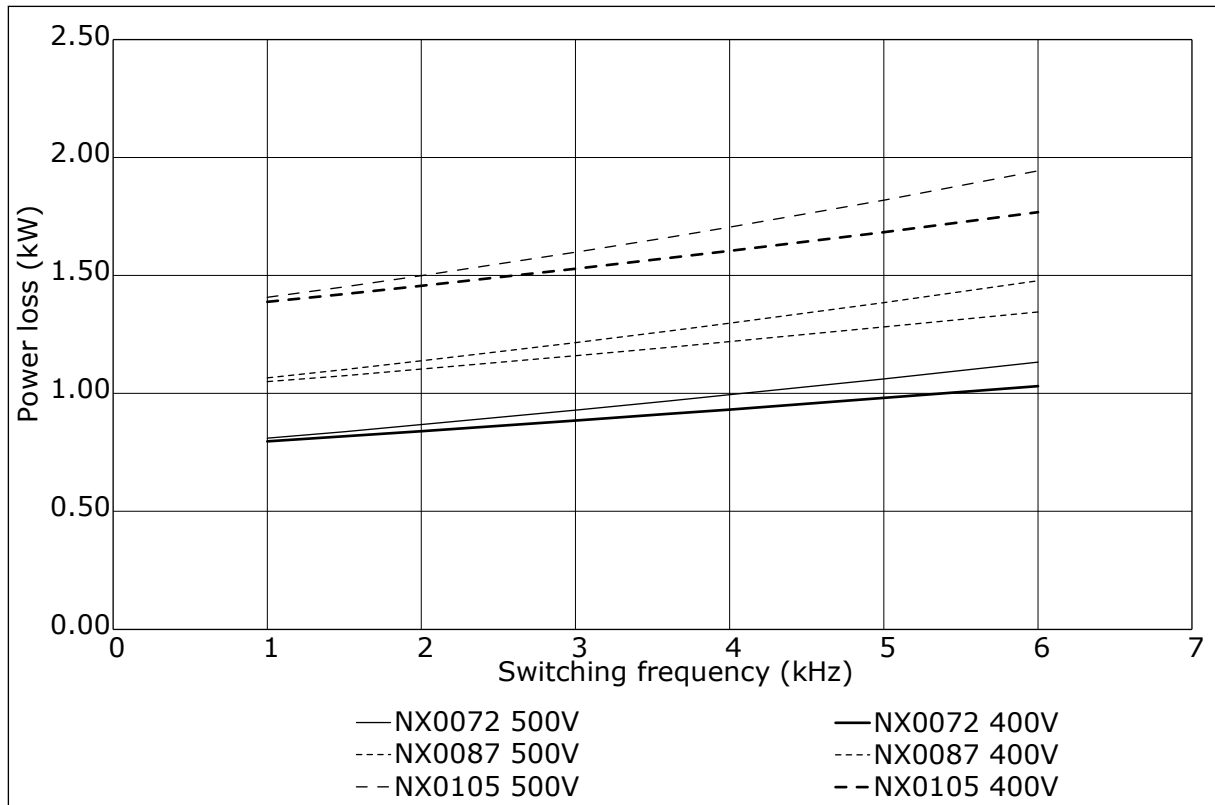

Fig. 41: Power loss as function of switching frequency; NXS or NXP 0072-0105

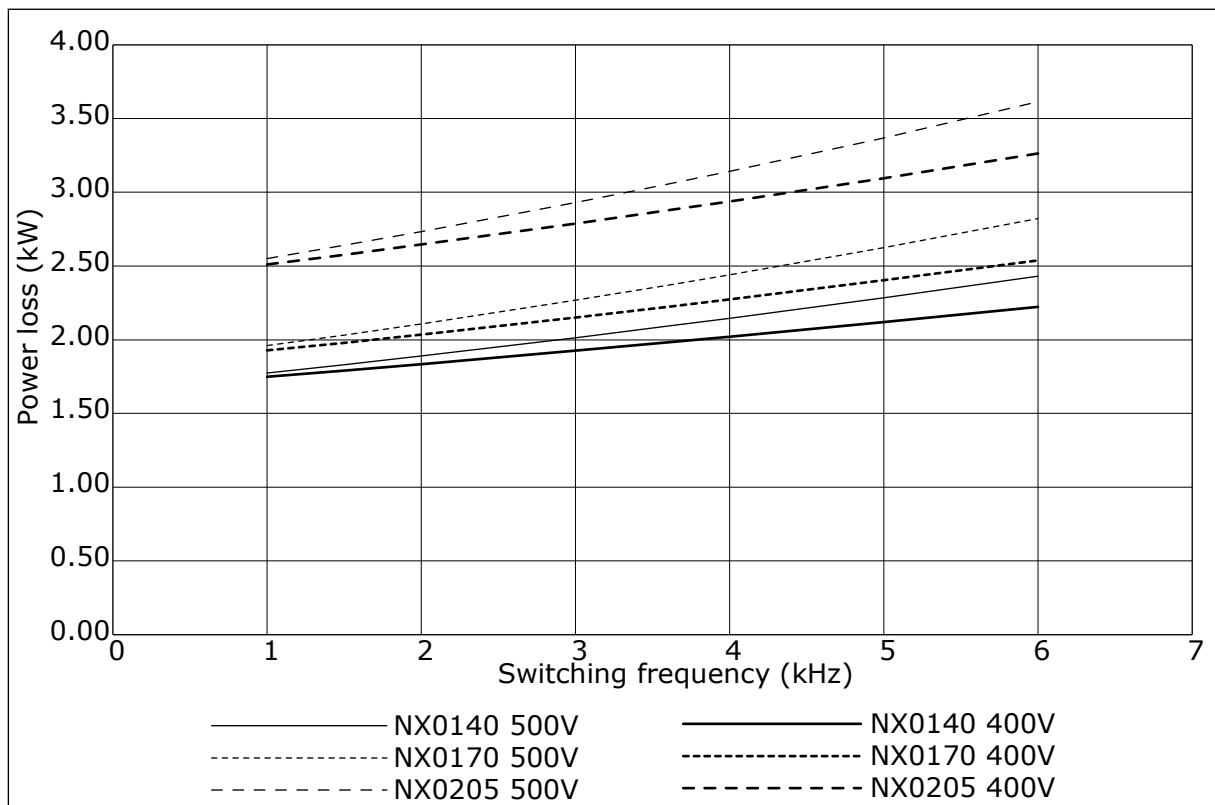

Fig. 42: Power loss as function of switching frequency; NXS or NXP 0140-0205

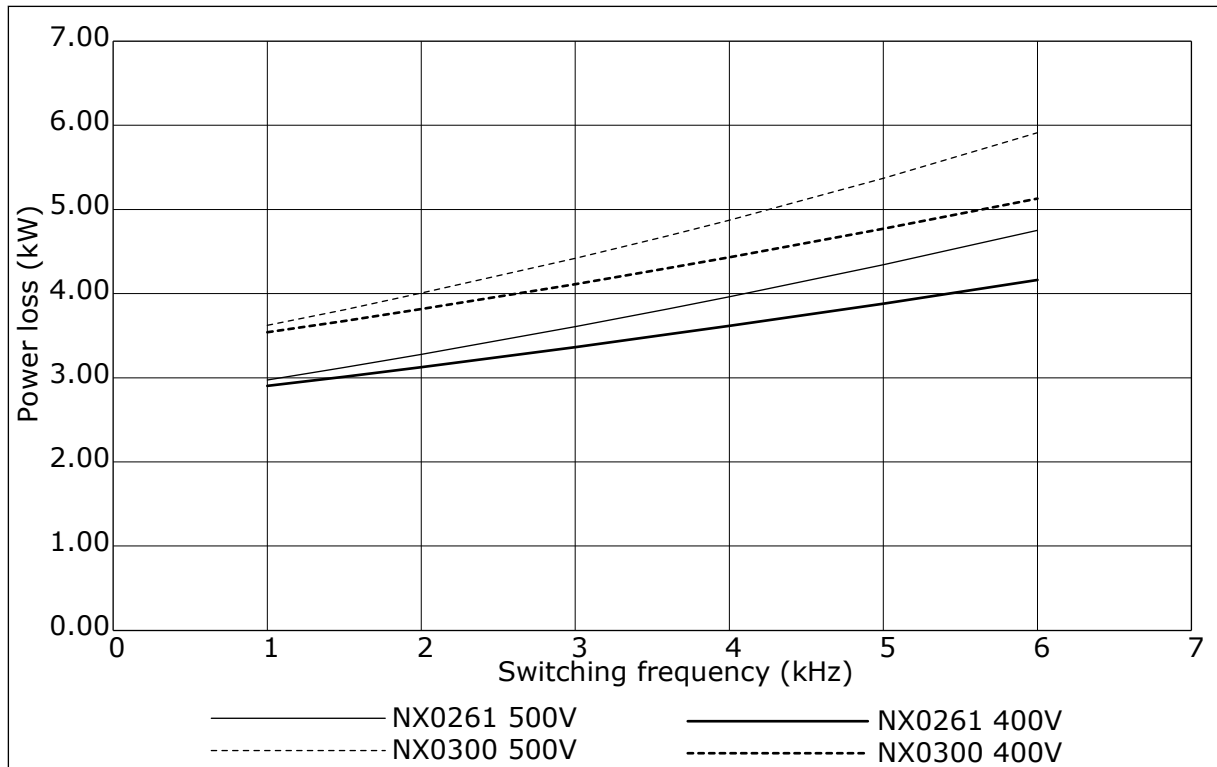

Fig. 43: Power loss as function of switching frequency; NXS or NXP 0261-0300

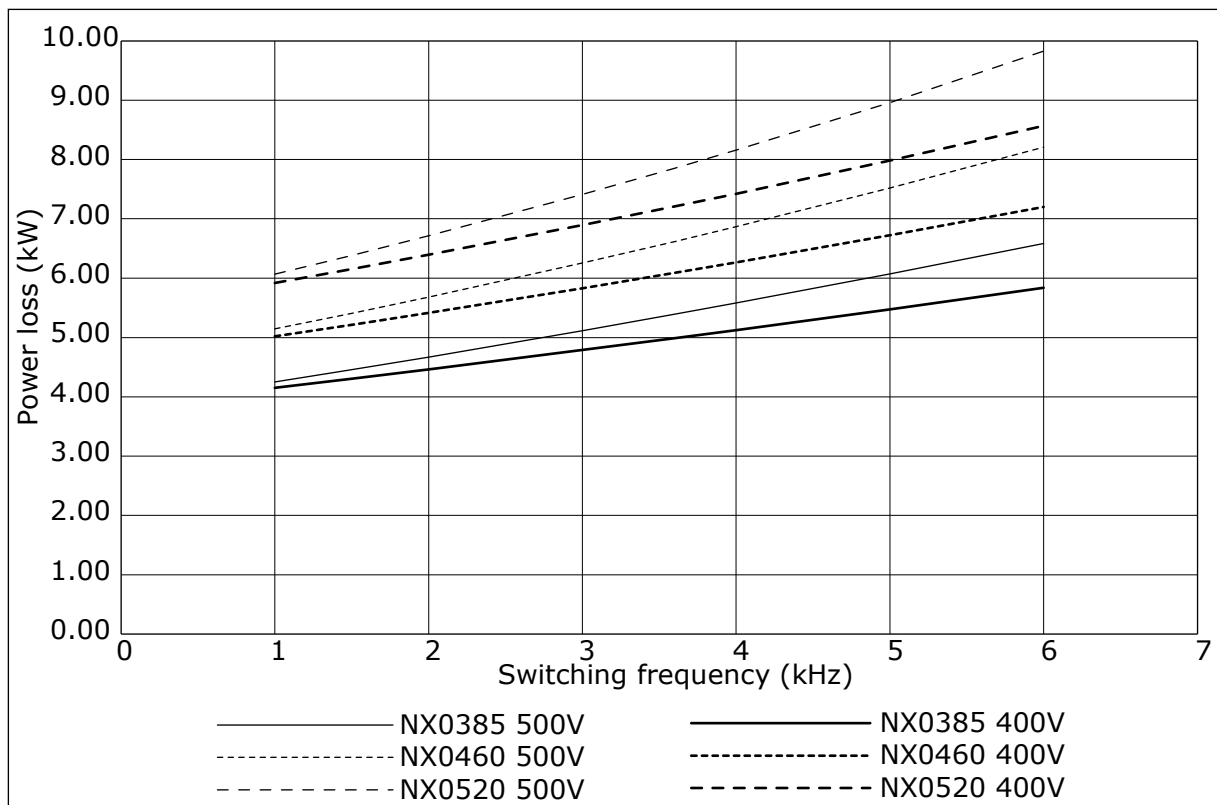

Fig. 44: Power loss as function of switching frequency; NXS or NXP 0385-0520

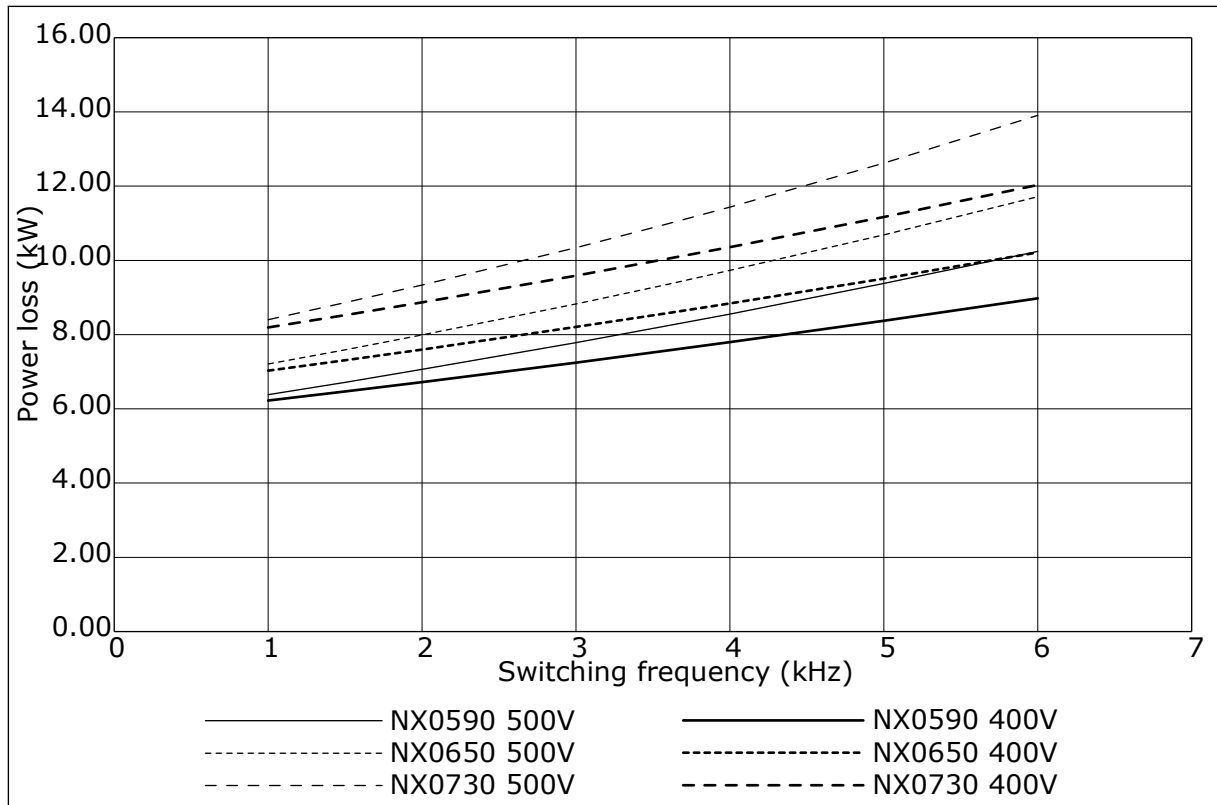

Fig. 45: Power loss as function of switching frequency; NXS or NXP 0590-0730

### 11.2 POWER LOSSES OF 525-690 V

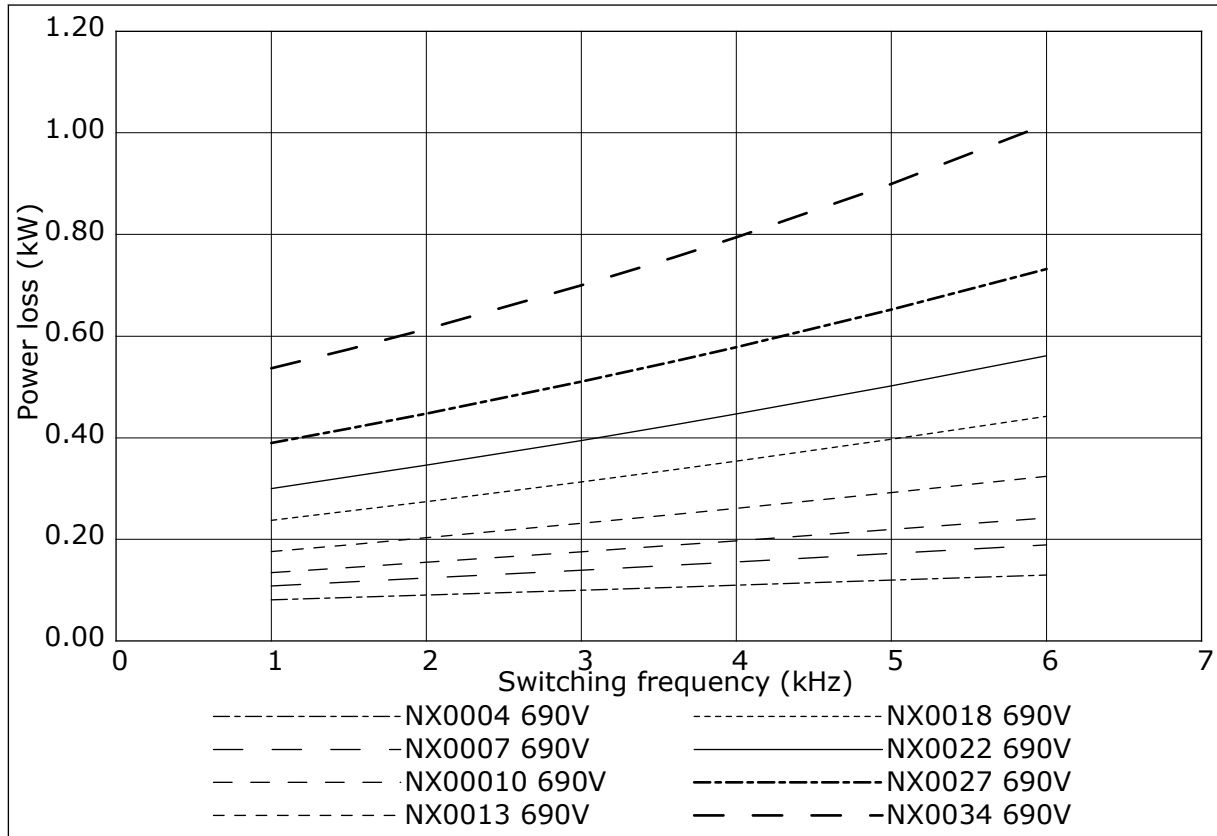

Fig. 46: Power loss as function of switching frequency; NXS or NXP 0004-0034

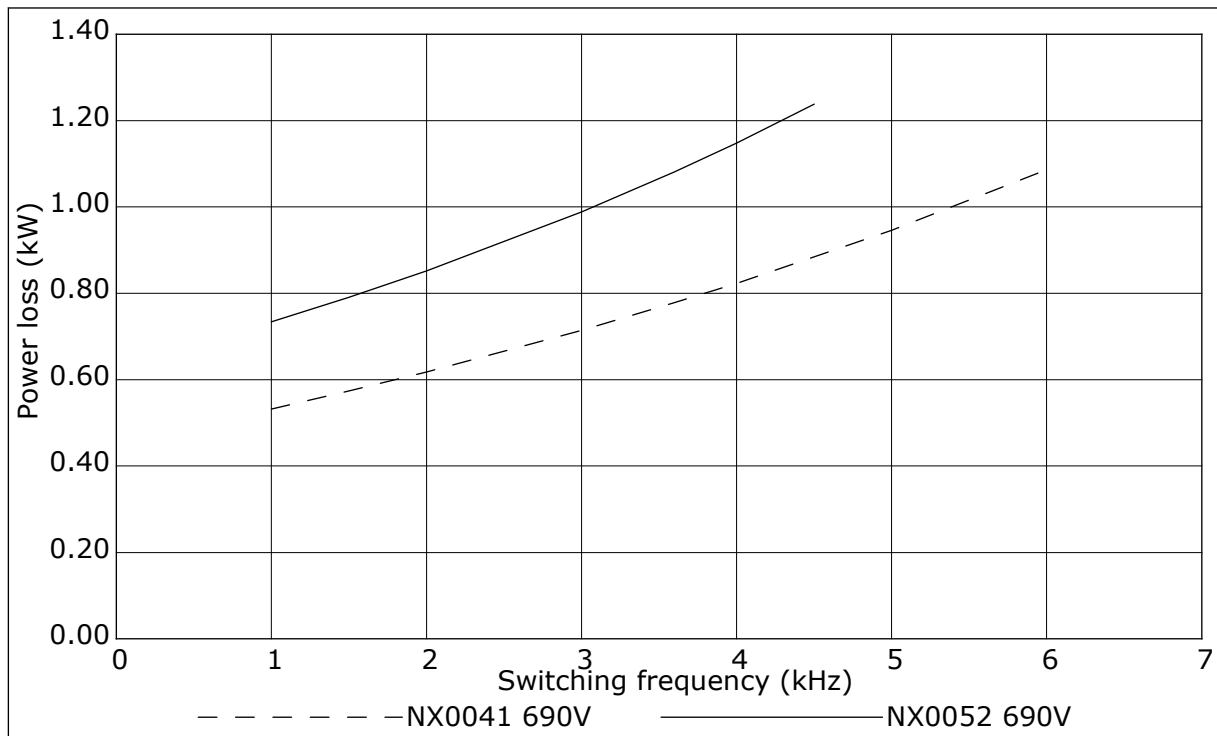

Fig. 47: Power loss as function of switching frequency; NXS or NXP 0041-0052

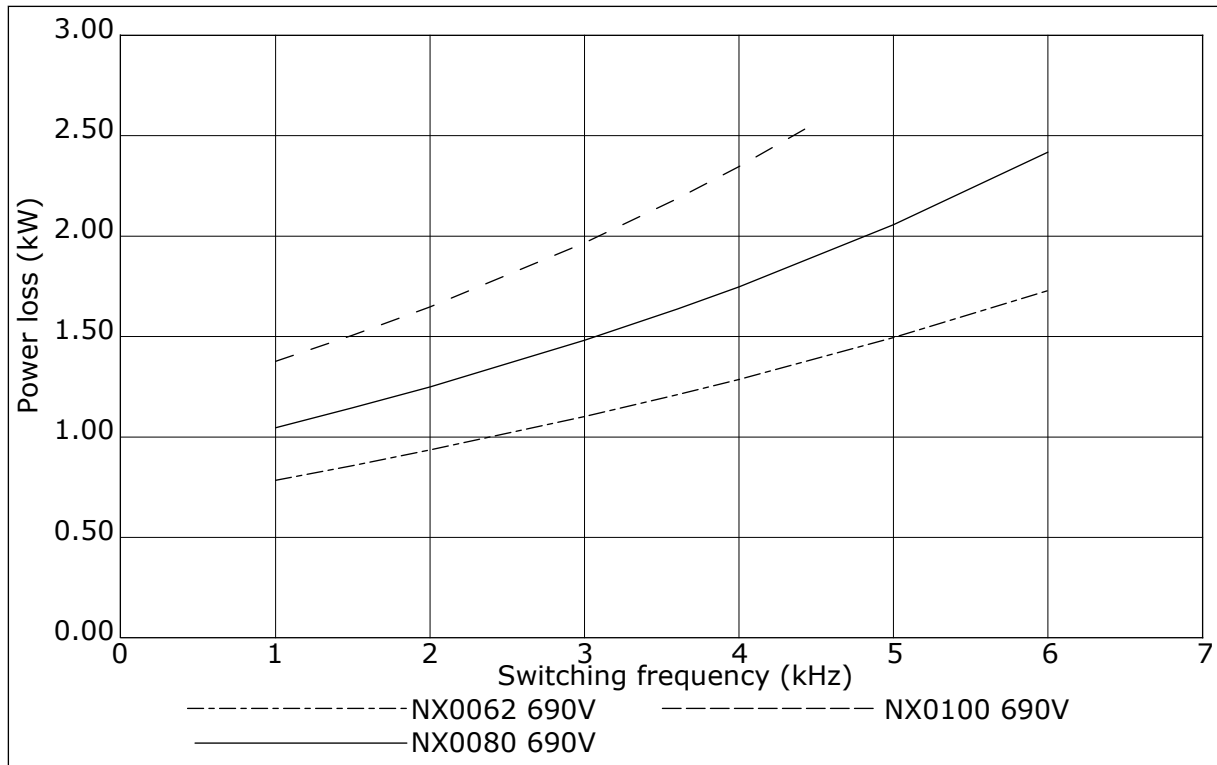

Fig. 48: Power loss as function of switching frequency; NXS or NXP 0062-0100

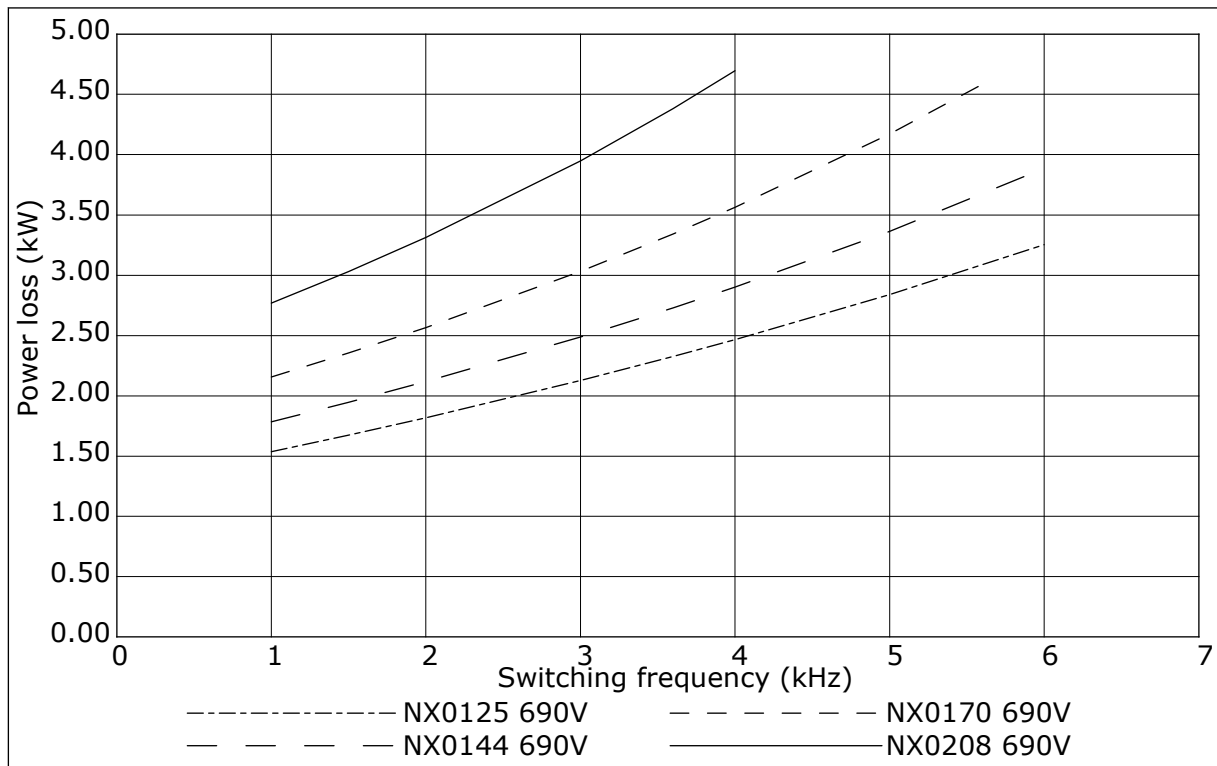

Fig. 49: Power loss as function of switching frequency; NXS or NXP 0125-0208

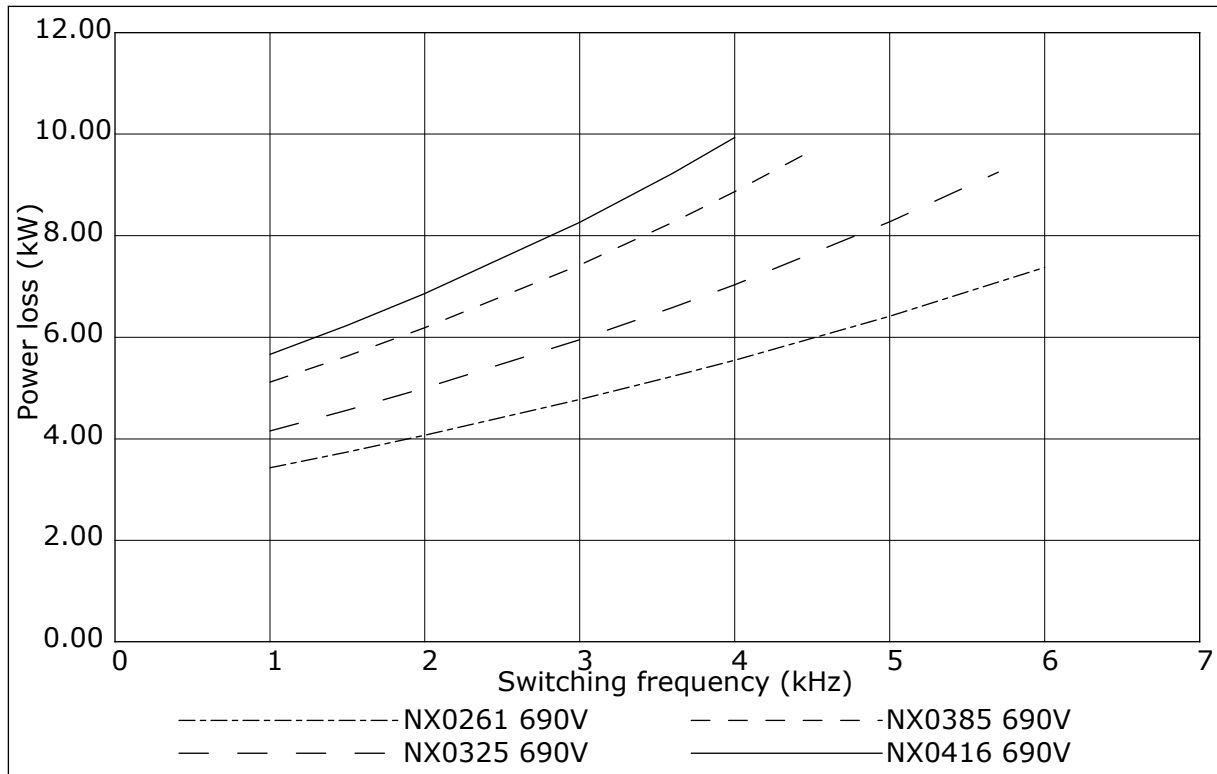

Fig. 50: Power loss as function of switching frequency; NXS or NXP 0261-0416

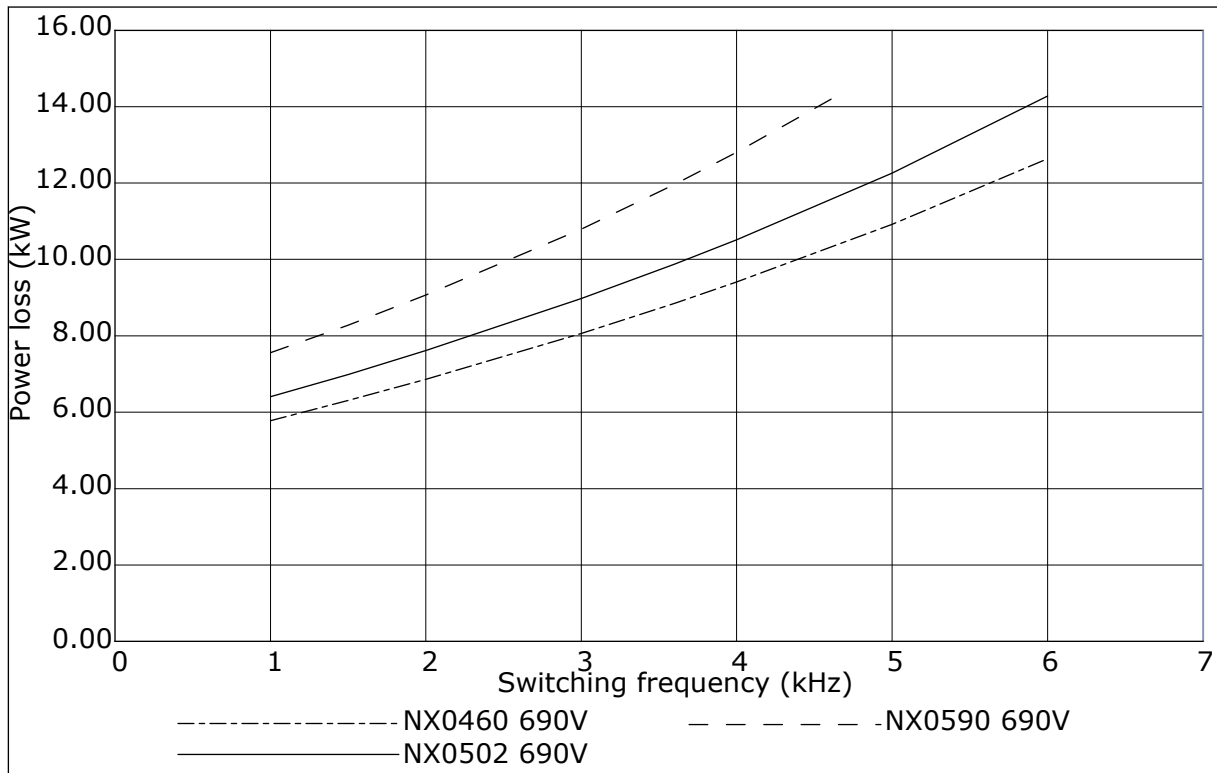

Fig. 51: Power loss as function of switching frequency; NXS or NXP 0460-0590



# VACON<sup>®</sup>

[www.danfoss.com](http://www.danfoss.com)

Vacon Ltd  
Member of the Danfoss Group  
Runsorintie 7  
65380 Vaasa  
Finland

Document ID:



DPD00910F

Rev. F

Sales code: DOC-INSNXS/NXP+DLUK