

Installation Instructions

Bus Decoupling Kit

VLT[®] Midi Drive FC 280

The bus decoupling kit ensures mechanical fixation and electrical screening of cables for the following control cassette variants:

- Control cassette with PROFIBUS.
- Control cassette with PROFINET.
- Control cassette with CANopen.
- Control cassette with Ethernet.

Each bus decoupling kit contains 1 horizontal decoupling plate and 1 vertical decoupling plate. Mounting the vertical decoupling plate is optional. The vertical decoupling plate provides better mechanical support for PROFINET and Ethernet connectors and cables.

Items Supplied

Ordering number	Items supplied
132B0369	Bus decoupling kit, containing the following items: <ul style="list-style-type: none"> • Horizontal decoupling plate. • Vertical decoupling plate. • 4 M3x6 screws.

Table 1.1 Items Supplied

Safety Instructions

⚠ WARNING

DISCHARGE TIME

The frequency converter contains DC-link capacitors, which can remain charged even when the frequency converter is not powered. High voltage can be present even when the warning LED indicator lights are off. Failure to wait the specified time after power has been removed before performing service or repair work can result in death or serious injury.

- Stop the motor.
- Disconnect AC mains and remote DC-link power supplies, including battery back-ups, UPS, and DC-link connections to other frequency converters.
- Disconnect or lock PM motor.
- Wait for the capacitors to discharge fully. The minimum waiting time is specified in *Table 1.2*.
- Before performing any service or repair work, use an appropriate voltage measuring device to make sure that the capacitors are fully discharged.

Voltage [V]	Power range [kW (hp)]	Minimum waiting time (minutes)
200–240	0.37–3.7 (0.5–5)	4
380–480	0.37–7.5 (0.5–10)	4
	11–22 (15–30)	15

Table 1.2 Discharge Time

Mounting

To mount the bus decoupling kit:

1. Place the horizontal decoupling plate on the control cassette that is mounted on the frequency converter, and fasten the plate using 2 screws, as shown in *Illustration 1.1*. Tightening torque 0.7–1.0 Nm.
2. Optional: Mount the vertical decoupling plate as follows:
 - 2a Remove the 2 mechanical springs and 2 metal clamps from the horizontal plate.
 - 2b Mount the mechanical springs and metal clamps on the vertical plate.
 - 2c Fasten the plate with 2 screws, as shown in *Illustration 1.2*. Tightening torque 0.7–1.0 Nm.

NOTICE

If the IP21 top cover is used, do not mount the vertical decoupling plate, because its height affects the proper installation of the IP21 top cover.

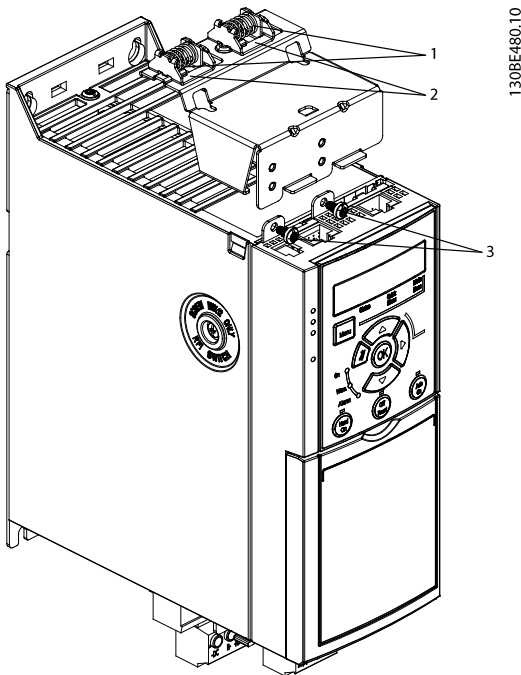

1	Mechanical springs
2	Metal clamps
3	Screws

Illustration 1.1 Fasten the Horizontal Decoupling Plate with Screws

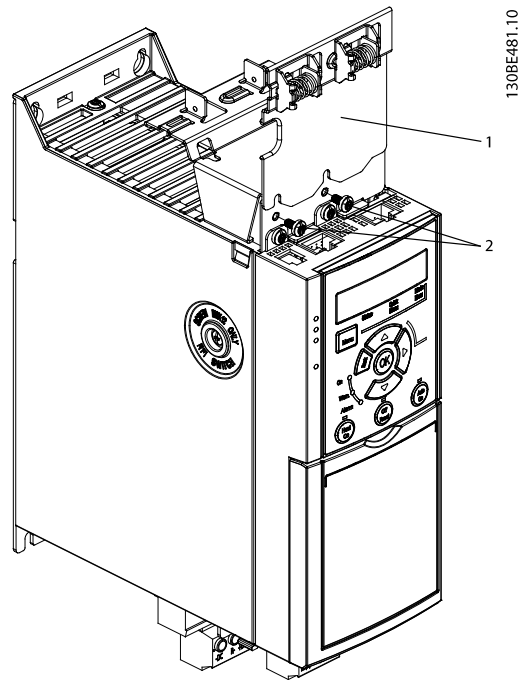

1	Vertical decoupling plate
2	Screws

Illustration 1.2 Fasten the Vertical Decoupling Plate with Screws

Both *Illustration 1.1* and *Illustration 1.2* show PROFINET sockets. The actual sockets are based on the type of the control cassette mounted on the frequency converter.

3. Push the PROFIBUS/PROFINET/CANopen/Ethernet cable connectors into the sockets in the control cassette.
4.
 - 4a Place the PROFIBUS/CANopen cables between the spring-loaded metal clamps to establish mechanical fixation and electrical contact between the screened sections of the cables and the clamps.
 - 4b Place the PROFINET/Ethernet cables between the spring-loaded metal clamps to establish mechanical fixation between the cables and the clamps.

.....
 Danfoss can accept no responsibility for possible errors in catalogues, brochures and other printed material. Danfoss reserves the right to alter its products without notice. This also applies to products already on order provided that such alterations can be made without consequential changes being necessary in specifications already agreed. All trademarks in this material are property of the respective companies. Danfoss and the Danfoss logotype are trademarks of Danfoss A/S. All rights reserved.

