



KEYPAD REMOTE CONTROL OPTIONS

INSTALLATION MANUAL

DPD00109

Need Help?

This manual answers most installation and startup questions that may arise. However, if you have any problems, please let your first call be to us.

Vacon, Inc.
Chambersburg, PA 17202

Normal business hours:
(North America)

8:00 AM to 5:00 PM, Eastern time

+1 877-Vacon06

(+1 877-822-6606)

After-hours support is also available



and Vacon, Inc. are trademarks of Vacon Plc, a member of Vacon Group.
All other product names are trademarks of their respective companies.

Copyright 2008, Vacon, Incorporated. All rights reserved.

INSTALLING KEYPAD REMOTE CONTROL OPTIONS

INTRODUCTION

Remote control options allow the keypad functionality of the **X4 and X5 AC drives** to be used remotely from the controller itself. The options provide a NEMA 4X / IP66 rating for the keypad in a remote location. Products covered by this instruction manual include **XRKPM**, **XRKWM**, and **XRKMK**.

The **XRKPM** is used with X4 or X5 drives of sizes 0, 1, and 2, when the drive is panel mounted and there is no need for the controller to maintain its designed NEMA 4X / IP66 rating.

The **XRKWM** is used with X4 or X5 drives of sizes 0, 1, and 2, when the drive is wall-mounted and it is imperative that the controller's normal enclosure rating be maintained.

The **XRKMK** is used with size 3, 4, and 5 drives, and allows the keypad to be mounted in a NEMA 4X / IP66 enclosure, while allowing the drive to maintain its designed rating (sizes 3 and 4 are NEMA 4X / IP66; size 5 is NEMA 12/IP55).

This manual is organized so that each of the products can be installed by following the steps outlined below:

XRKPM (panel-mounted)	Follow Steps 1, 2, 3, 4, 5
XRKWM (wall-mounted)	Follow Steps 1, 2, 6, 7, 8
XRKMK (enclosure-mounted)	Follow Steps 1, 9, 10, 11, 12

OPTION KIT CONTENTS

The option kits include the following materials:

XRKPM	XRKWM	XRKMK
Keypad module housing (2) ¹	Keypad module housing (2) ¹	Keypad interface board
Keypad interface board	Keypad interface board	Keypad interface assembly
Remote keypad assembly	Remote keypad assembly	Connector stacker
Overlay	Overlay	Loop clamps
Ribbon cable (12 feet)	Wire tie (5)	Wire tie (4)
Ribbon cable clamps (4)	Wire tie base (4)	Wire tie base (4)
Screw: M2.5x6 (3) ²	Screw: M2.5x6 (3) ²	Screw: M3.5x10 (5) ²
Screws: M5x12 (4) ³	Screws: M5x12 (4) ³	Screws: M5x12 (4) ³

- NOTES:**
1. Only one will be used.
 2. To mount the keypad interface board into the proper keypad interface housing
 3. To mount the remote keypad assembly into the host enclosure

For the **XRKWM** and the **XRKMK**, customers must supply shielded cable. Belden #22418 or the equivalent is suggested. Fifteen circuits are required, but may be accomplished with multiple strands of cable, each with fewer conductors. This cable should not exceed 100 feet in length.

⚠ WARNING**SENSITIVE EQUIPMENT**

The keypad contains static-sensitive components. It should be handled only by a static-safe installer, using a grounded wrist strap.

Failure to observe this precaution may cause premature equipment failure.

⚠ DANGER**HAZARDOUS VOLTAGE**

- Disconnect all power before servicing a drive unit or its components. **WAIT 5 MINUTES** until the DC bus capacitors discharge.
- Ensure that any other power sources that may feed control logic have been disconnected.
- **DO NOT** short across DC bus capacitors or touch unshielded components or terminal strip screw connections with voltage present.
- Install all covers before applying power or starting and stopping the drive.
- The user is responsible for conforming to all applicable code requirements with respect to grounding all equipment.
- Many parts in this drive, including printed circuit boards, operate at line voltage. **DO NOT TOUCH.** Use only electrically-insulated tools.

Before servicing any drive.

- Disconnect all power.
- Place a "DO NOT TURN ON" label on the drive disconnect.
- Lock the disconnect in the open position.

Failure to observe these precautions will cause shock or burn, resulting in severe personal injury or death.

Step 1. Preparing the Host Enclosure (XRKPM, XRKWM, and XRKMK)

Figure 1 on page 5 is a layout for remote keypad assembly mounting.

If you are fabricating a simple remote control station with this option, the following standard enclosure suggestions are recommended: Hoffman #A1008CHNF or Hammond #1414N4PHI.

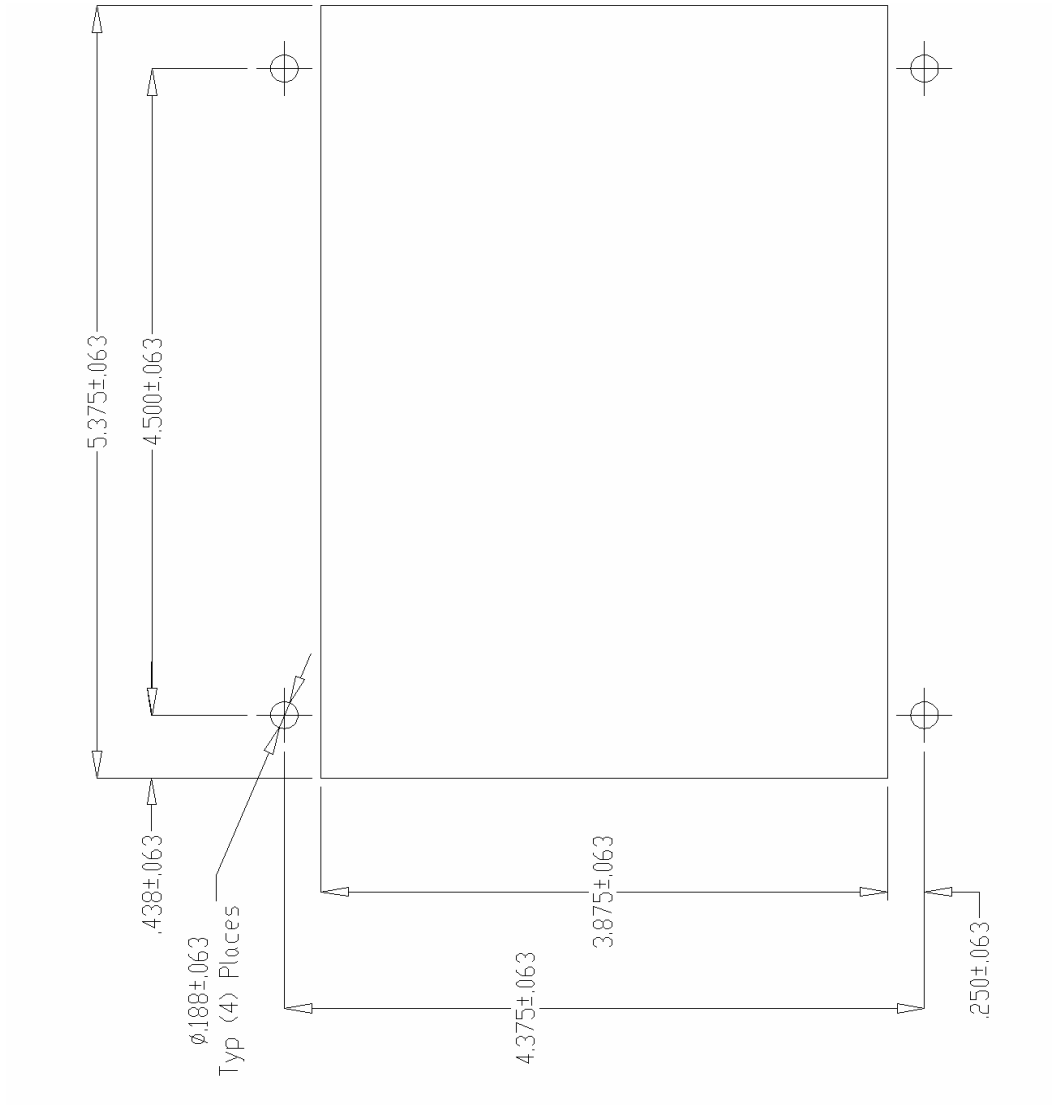

Figure 1: Dimensions of Remote Keypad Kit

Step 2. AC Drive Preparation (XRKPM, XRKWM)

Note: For drive sizes 3 and larger (XRKMK), skip to [step 9](#), beginning on page 13, and proceed through Step 12.

1. Note the warnings and cautions on the unit and in the user's manual.
2. Loosen the four (4) cover screws from the AC drive and remove the cover.
3. Remove the two (2) screws that secure the keypad assembly and retain these for future use. These are M4 x 10 screws.
4. Remove the keypad assembly. It will not be used in the final assembly, but may be useful as a replacement part in another unit. If you will be storing it for a long period of time, re-use the static bag that the remote keypad assembly came in.

For the **XRKPM**, perform [steps 3-5](#), beginning on [page 7](#). For the **XRKWM**, perform [steps 6-8](#), beginning on [page 10](#).

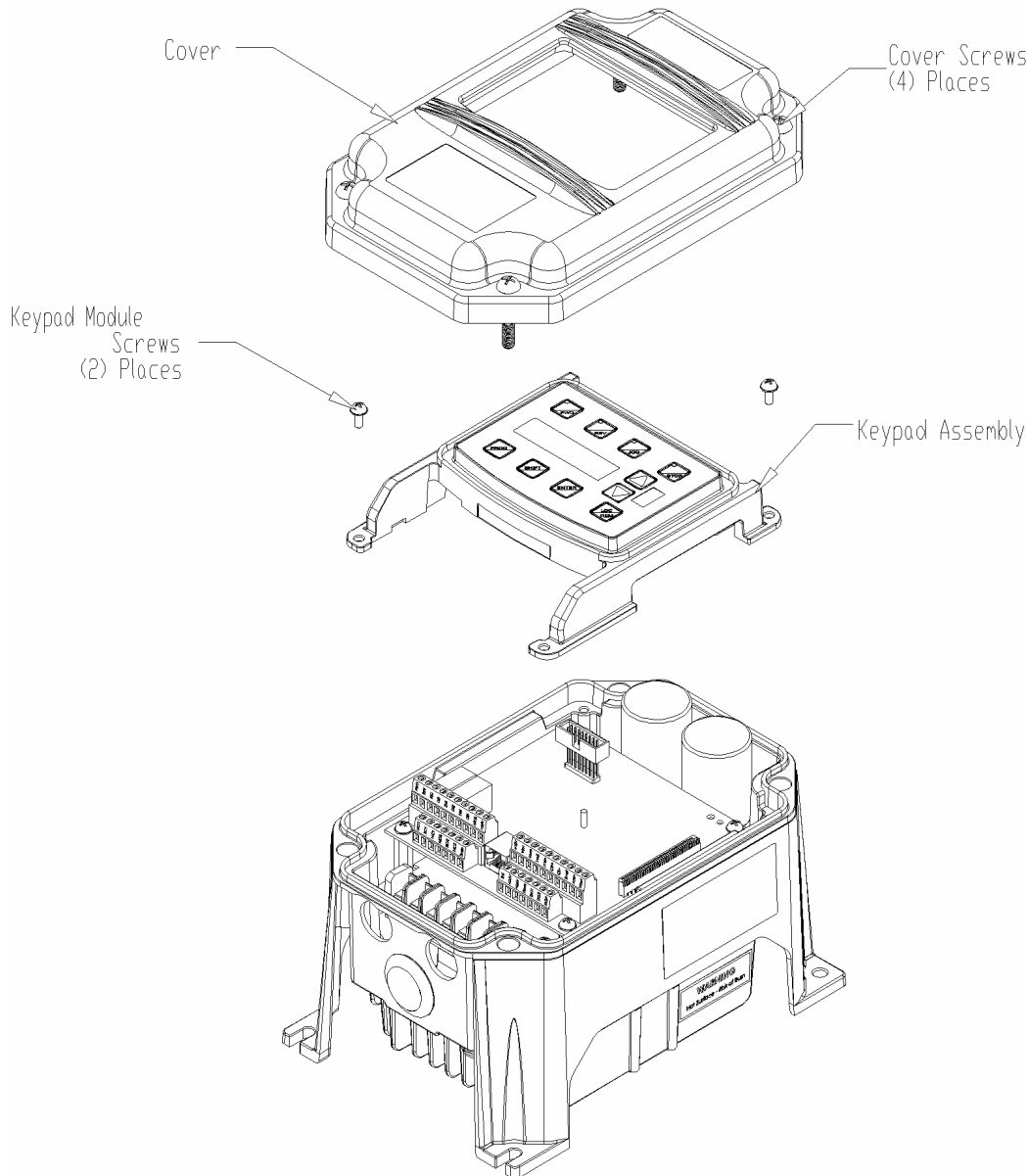

Figure 2: Removing the Keypad Assembly (XRKPM and XRKWM)

Step 3. Preparing the Keypad Interface Module (KIM) (XRKPM only)

1. There are two housings supplied with the kit; only one will fit your AC drive properly. Select the keypad module housing that physically matches the one you removed in [Step 2](#).
2. Insert the keypad interface board into the rear of the plastic housing that you selected.
3. Fasten it with the three (3) M2.5 x 6 screws provided, limiting the torque applied to 6 in-lb maximum.
4. Remove the adhesive covering liner from the overlay.
5. Align and adhere the overlay to the front side of the keypad module. Press the part down firmly to ensure adequate adhesion to the plastic housing.
6. Fasten a cable clamp to the outside of the overlay. (Positioning aids are visible on the surface.)
7. Connect the ribbon cable to the interface board through the opening in the overlay. To provide strain relief, route the cable through the cable clamp that you just installed.

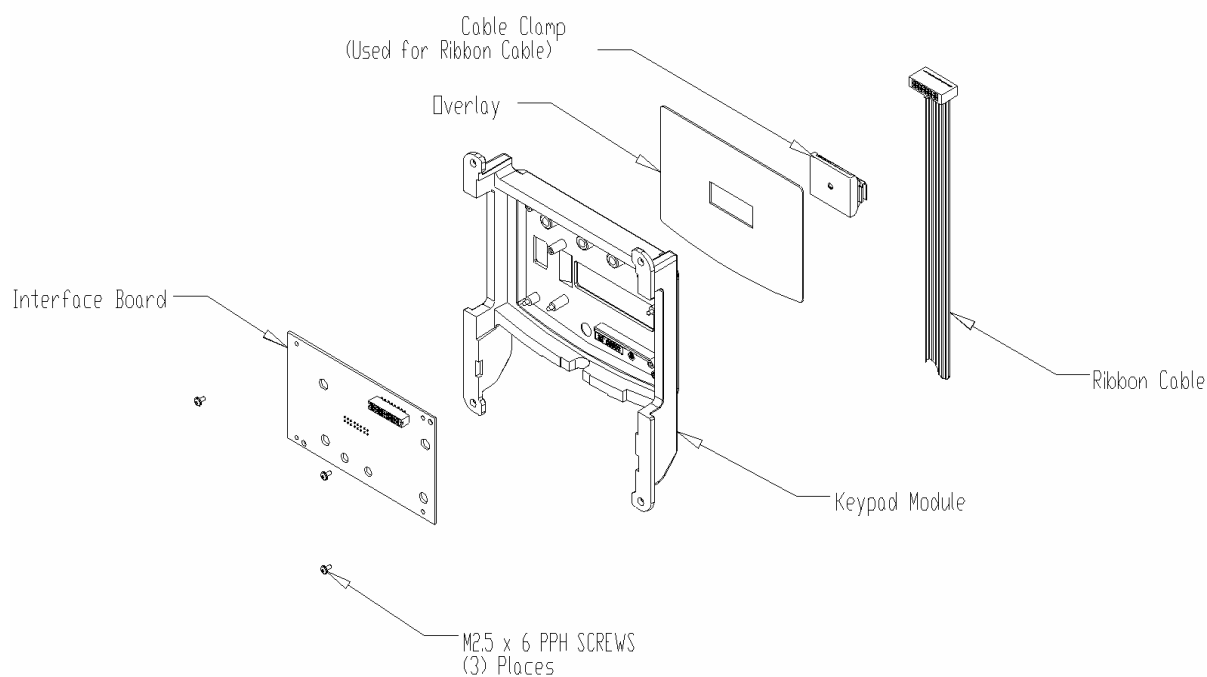

Figure 3: Preparing the Keypad Interface Module (XRKPM Option)

Step 4. Re-assembling the AC Drive (XRKPM only)

1. Plug the Keypad Interface Module (KIM) fabricated in Step 3 into the inverter, as it was originally (see [Step 2, #4](#)).
2. Fasten the KIM with the two (2) M4 x 10 screws removed in [Step 2](#), limiting torque to 12 in-lb. maximum.
3. Make sure that all cabling is routed so that it is not pinched in the assembly. The ribbon cable should be routed through the opening in the cover and should exit downward.
4. If or when you re-install the cover, route the ribbon cable through the opening and limit the installation torque on the cover screws to 26 in-lb. maximum.

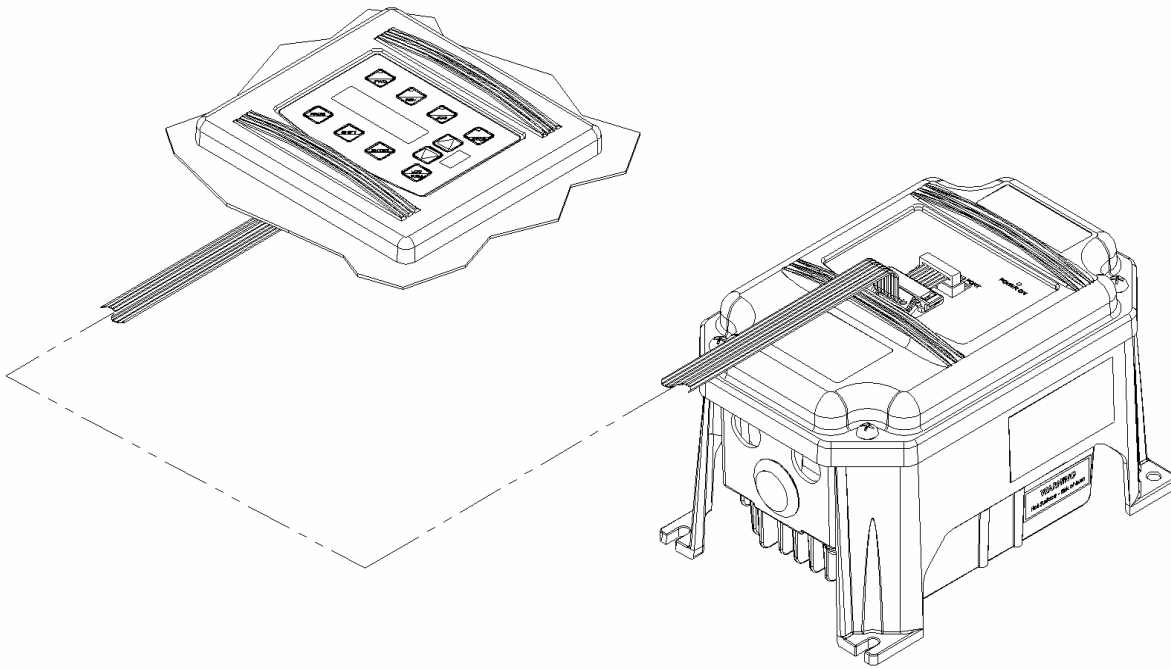

Figure 4: Re-assembling the AC Drive (XRKPM Option)

Step 5. Installing the Remote Keypad Assembly into the Host Enclosure (XRKPM only)

1. Position the remote keypad assembly into the enclosure prepared in [Step 1 \(page 4\)](#).
2. Fasten the keypad module with the four (4) M5 x 12 screws provided, limiting torque to 26 in-lb maximum.
3. Install a cable clamp below the keypad assembly as shown in the drawing, fastening it to the host enclosure. Connect the ribbon cable to the J1 connector and route it through the cable clamp. The cable should exit the keypad module downward.
4. Route the cabling as needed to avoid any damage. Additional cable clamps are provided to allow strain relief for the wire.

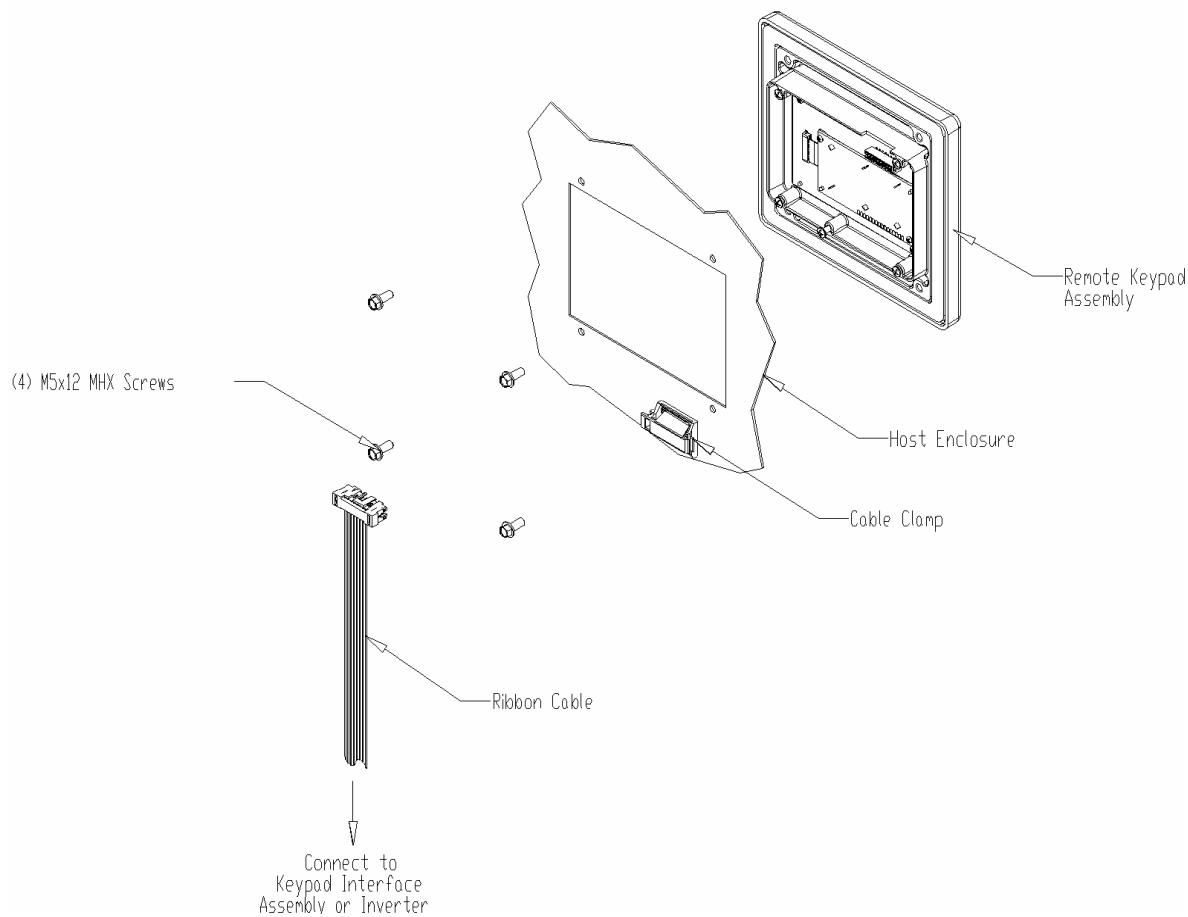

Figure 5: Installing the Remote Keypad Assembly into the Host Enclosure (XRKPM Option)

For detailed information on using the keypad, refer to the following documentation:

- DPD 00088, **X4 AC Drive User's Manual**
- DPD 00089, **X5 AC Drive User's Manual**

Step 6. Preparing the Keypad Interface Module (KIM) (XRKWM only)

(Note: You will need to provide a 15-conductor cable for this step.)

1. There are two housings supplied with the kit; only one will fit your AC drive properly. Select the keypad module housing that physically matches the one you removed in [Step 2](#) on [page 6](#).
2. Insert the keypad interface board into the rear of the plastic housing that you selected.
3. Fasten it with the three (3) M2.5 x 6 screws provided, limiting the torque applied to 6 in-lb maximum.
4. Remove the adhesive covering liner from the overlay.
5. Align and adhere the overlay to the front side of the keypad module. Press the part down firmly to ensure adequate adhesion to the plastic housing.
6. Install the tie wrap provided in the lower portion of the interface board. Connect the customer-supplied 15-conductor cable within the tie wrap and terminate to TB1 and TB2. Note the wire color assignments: this will be helpful later in this process ([Step 8](#)). For your convenience, TB1 and TB2 terminal blocks are removable.
7. Secure the cable shield(s) to Terminal 1.

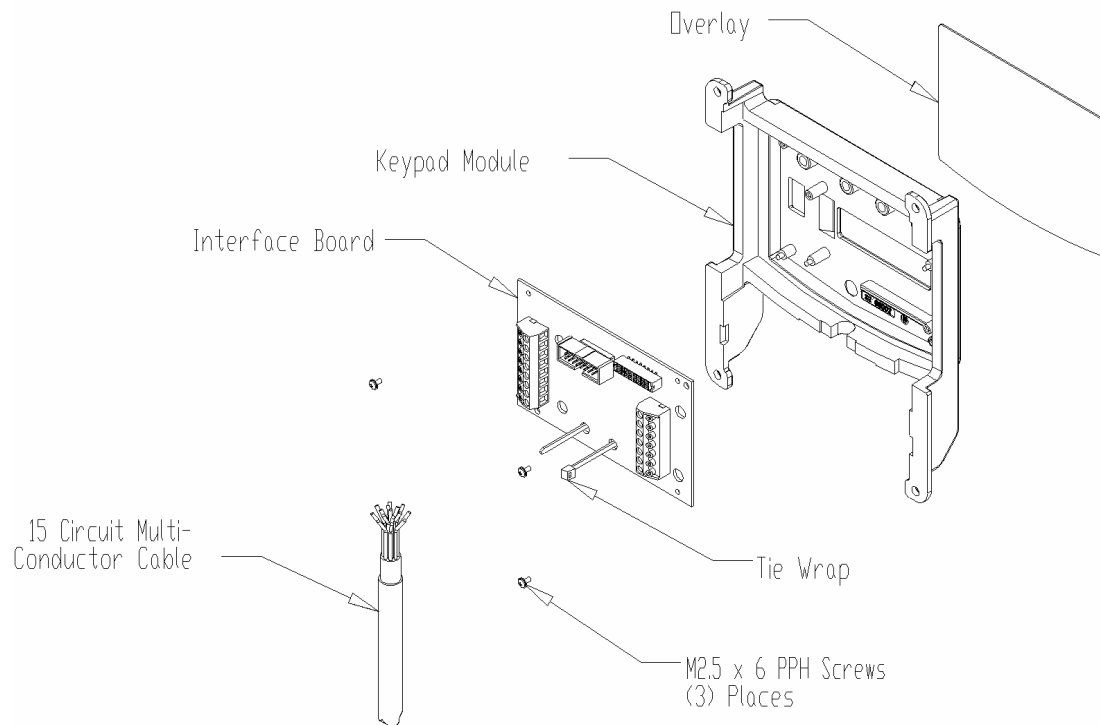

Figure 6: Preparing the Keypad Interface Module (XRKWM Option)

Step 7. Re-assembling the AC Drive (XRKWM only)

1. Plug the Keypad Interface Module (KIM) fabricated in the previous step into the inverter, as it was originally (see [Step 2, #4](#)).
2. Fasten the KIM with the two (2) M4 x 10 screws removed in [Step 2](#), limiting torque to 12 in-lb. maximum.
3. Make sure that all cabling is routed so that it is not pinched in the assembly. The multi-conductor must be routed through an unused conduit entry. Be sure to use the appropriate conduit fittings for your environment.
4. When you re-install the cover (required for NEMA 4X / IP66 integrity), limit the installation torque on the four (4) screws to 26 in-lb. maximum.

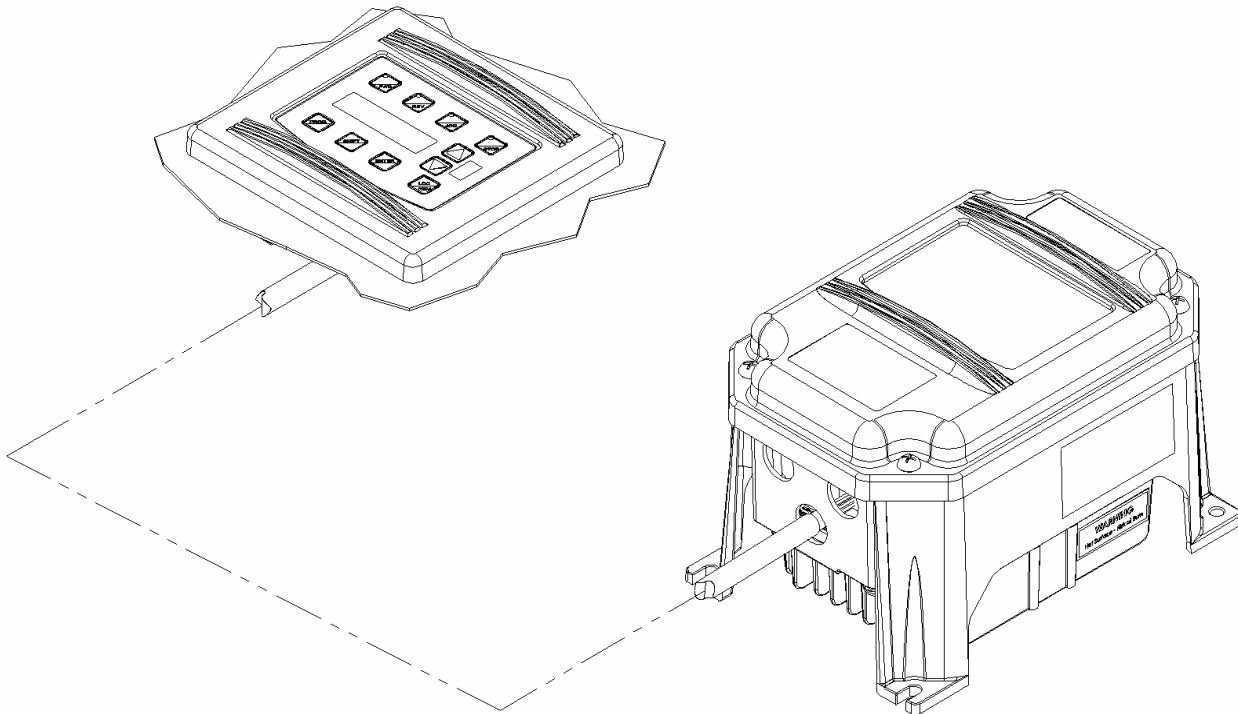

Figure 7: Re-assembling the AC Drive (XRKWM Option)

Step 8. Installing the Remote Keypad Assembly into the Host Enclosure (XRKWM only)

1. Position the remote keypad assembly into the enclosure prepared in [Step 1](#) (page 4).
2. Fasten the keypad module with the four (4) M5 x 12 screws provided, limiting torque to 26 in-lb maximum.
3. Secure the multi-conductor cable using the loop clamp on the lower portion of the keypad interface board. You may need to loosen the cable clamp to install the cable in it.
4. Terminate the individual wires to TB1 and TB2 as in [Step 6, #6](#). For your convenience, TB1 and TB2 terminal blocks are removable.
5. Route the cabling as needed to avoid any damage. Additional wire ties and tie bases are provided to allow strain relief for the wire.

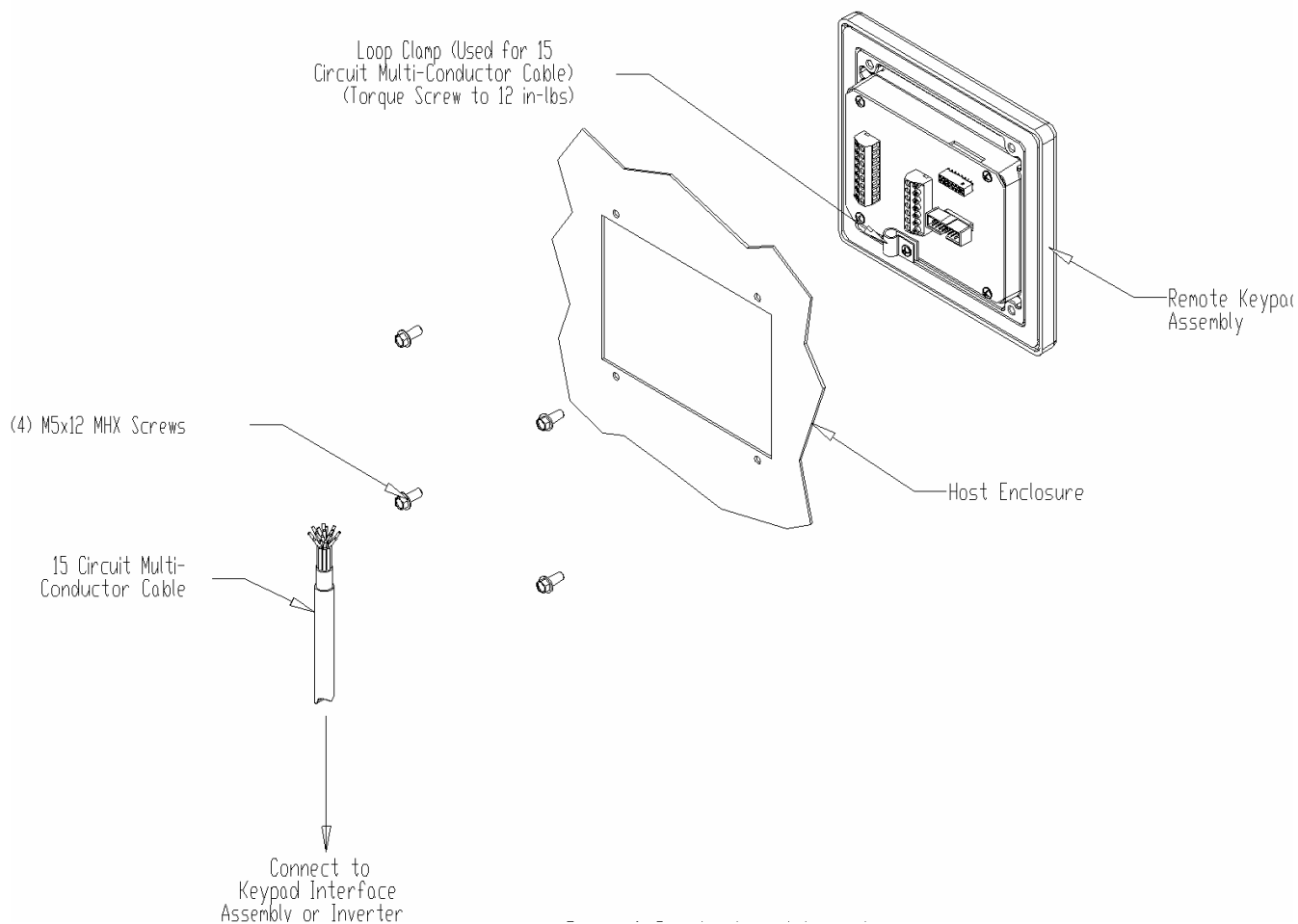

Figure 8: Installing the Remote Keypad Assembly into the Host Enclosure (XRKWM Option)

For detailed information on using the keypad, refer to the following documentation:

- DPD 00088, **X4 AC Drive User's Manual**
- DPD 00089, **X5 AC Drive User's Manual**

Step 9. AC Drive Preparation (XRKMK only)

1. Note the warnings and cautions on the unit and in the user's manual.
2. Loosen the cover screws from the AC drive and open the cover.
3. Remove the four (4) screws that secure the keypad assembly and retain these for future use. These are M5 x 12 screws.
4. Unplug the ribbon cable and remove the keypad assembly. It will be re-used in [Step 12](#).
5. Now go on to [Step 10](#), beginning on [page 14](#).

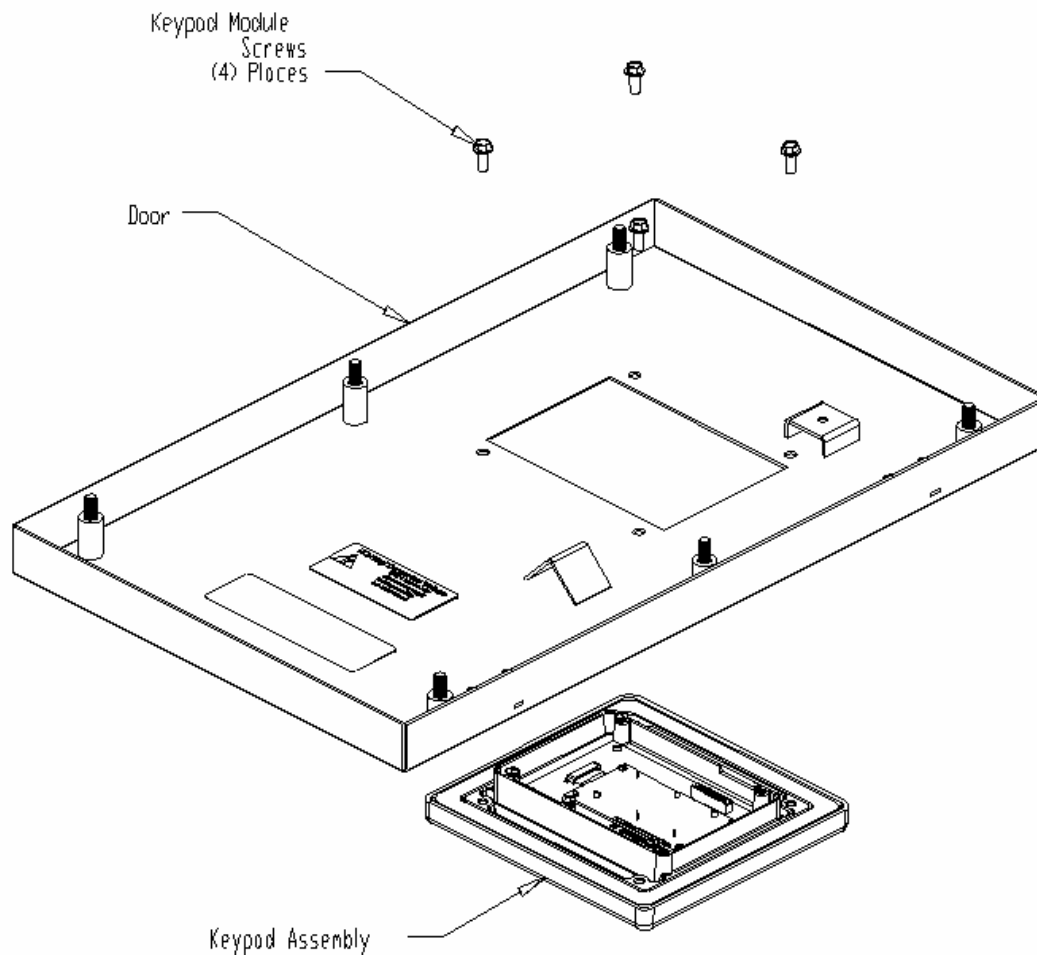

Figure 9: Removing the Keypad Assembly (XRKMK Option)

Step 10. Installing the Keypad Interface Module (KIM) into the AC Drive (XRKMK only)

1. Position the keypad interface module (KIM) into the door opening.
2. Fasten the keypad module with the four (4) M5 x 12 screws provided, limiting torque to 26 in-lb maximum.
3. Reconnect the ribbon cable to the connector socket and ensure it is still retained by the cable clamp on the door.
4. Secure the multi-conductor cable using the loop clamp on the lower portion of the keypad interface board. You may need to loosen the cable clamp to install the cable in it.
5. Terminate the individual wires to TB1 and TB2 as in [Step 6, #6](#). Note the wire color assignments; this will be useful in [Step 12](#). For your convenience, TB1 and TB2 terminal blocks are removable.
6. Secure the cable shield(s) to Terminal 1.
7. Route the cabling as needed to avoid any damage. The multi-conductor must be routed through an unused conduit entry. Be sure to use appropriate conduit fittings for your environment. Additional wire ties and tie bases are provided to allow strain relief for the wire.
8. As you fasten the enclosure, limit the installation torque to 26 in-lb. maximum.

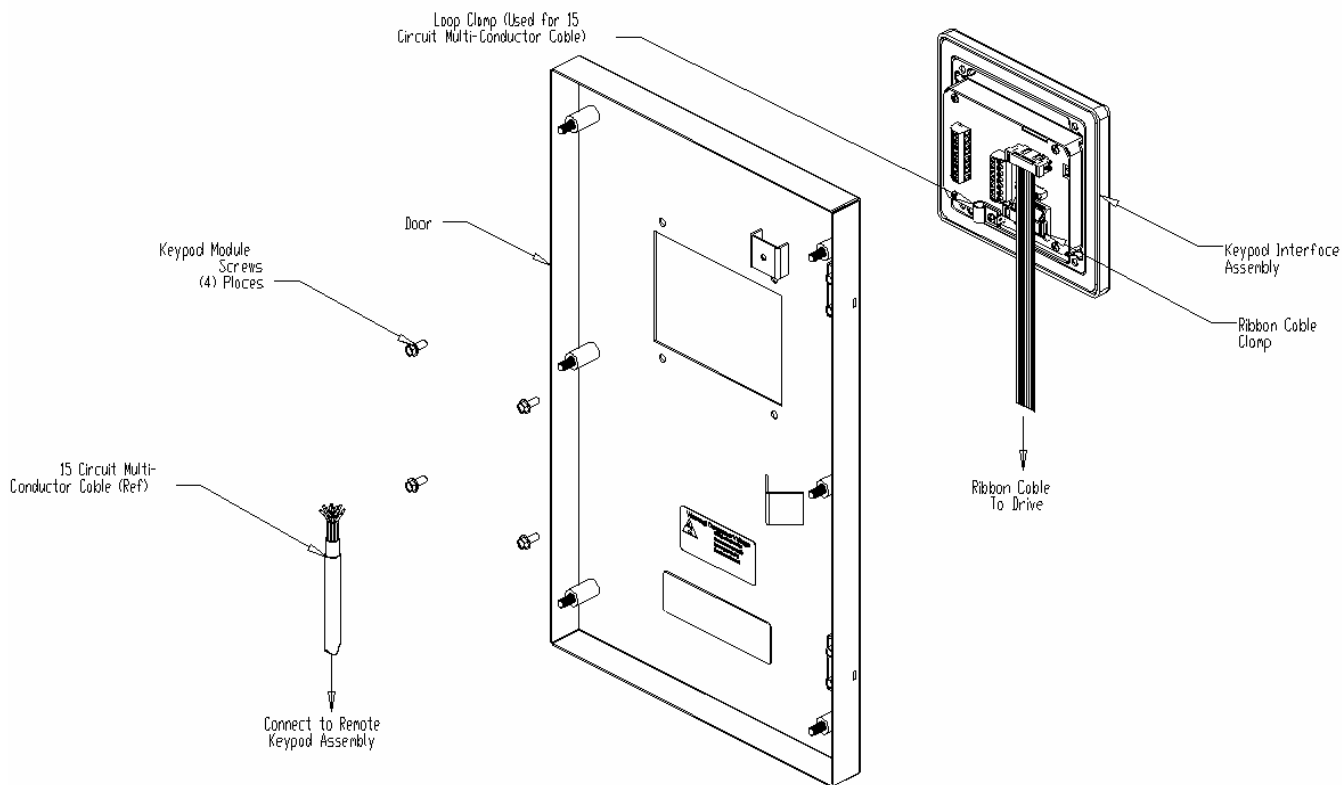

Figure 10: Installing the KIM into the AC Drive (XRKMK Option)

Step 11. Assembling the Remote Keypad Interface (XRKMK only)

1. Insert the connector stacker into the receptacle on the remote keypad assembly (removed in [Step 9](#)) as shown in [Figure 11](#) below.
2. Insert the keypad interface board onto the rear of the keypad assembly, being sure to engage the connector stacker simultaneously.
3. Fasten the keypad interface assembly with five (5) M3.5 x 10 screws along with the loop clamp provided. Limit installation torque to 12 in-lb. maximum.

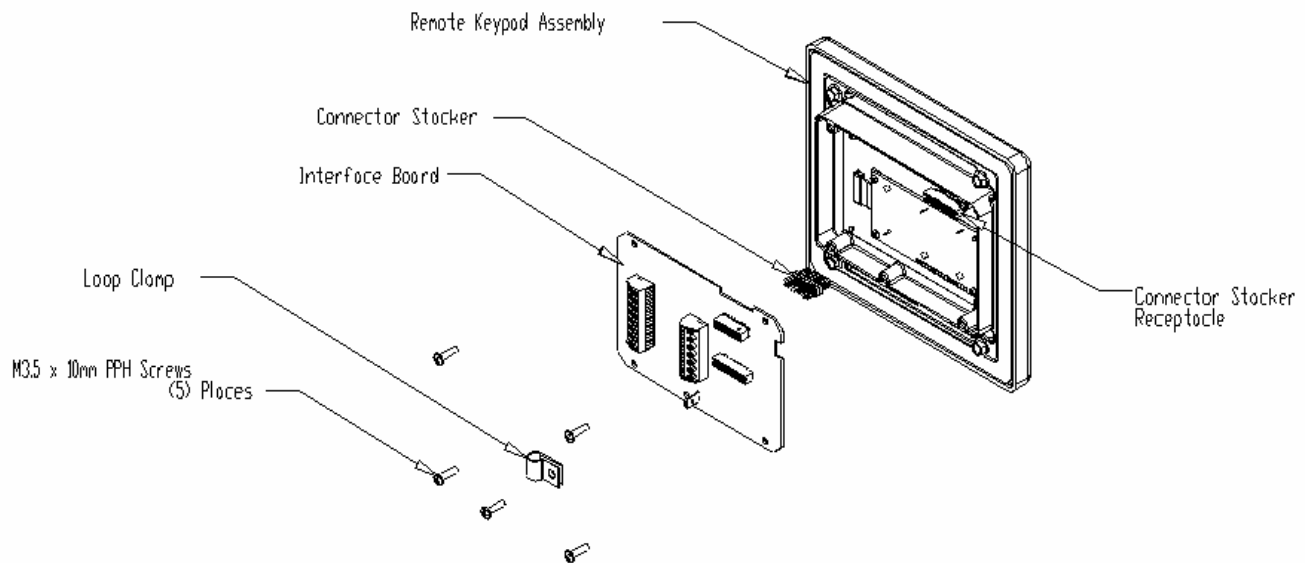

Figure 11: Assembling the Remote Keypad Interface (XRKMK Option)

Step 12. Installing the Remote Keypad Assembly into the Host Enclosure (XRKMK only)

1. Position the remote keypad assembly into the enclosure prepared in [Step 1](#) (page 4).
2. Fasten the keypad module with the four (4) M5 x 12 screws provided, limiting torque to 26 in-lb maximum.
3. Secure the multi-conductor cable using the loop clamp on the lower portion of the keypad interface board. You may need to loosen the cable clamp to install the cable in it.
4. Terminate the individual wires to TB1 and TB2 as in [Step 10](#). For your convenience, TB1 and TB2 terminal blocks are removable.
5. Route the cabling as needed to avoid any damage. Additional wire ties and tie bases are provided to allow strain relief for the wire.

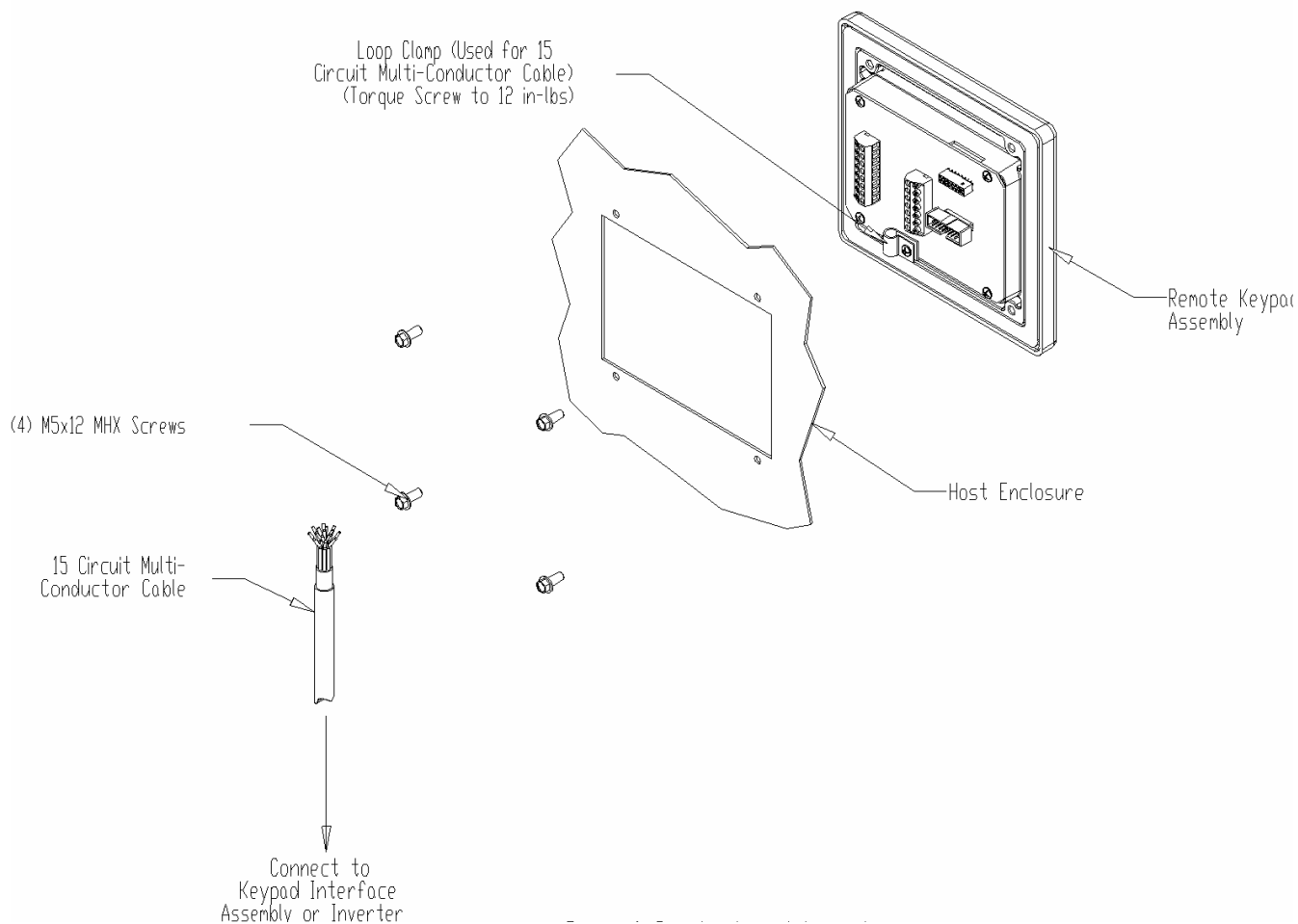

Figure 12: Installing the Remote Keypad Assembly into the Host Enclosure (XRKMK Option)

For detailed information on using the keypad, refer to the following documentation:

- DPD 00088, **X4 AC Drive User's Manual**
- DPD 00089, **X5 AC Drive User's Manual**

NOTES

HEAD OFFICE AND PRODUCTION:**Vaasa**

Vacon Plc
Runsorintie 7
65380 Vaasa
firstname.lastname@vacon.com
telephone: +358 (0)201 2121
fax: +358 (0)201 212 205

PRODUCTION:**Suzhou, China**

Vacon Suzhou Drives Co. Ltd.
Building 11A
428# Xinglong Street, SIP
Suchun Industrial Square
Suzhou 215126
telephone: +86 512 62836630
fax: +86 512 62836618

Naturno, Italy

Vacon S.R.l
Via Zone Industriale, 11
39025 Naturno

PRODUCTION:**Chambersburg, USA**

3181 Black Gap Road
Chambersburg, PA 17202

TB Wood's (India) Pvt. Ltd.

#27, 'E' Electronics City
Hosur Road
Bangalore - 560 100
India
Tel. +91-80-30280123
Fax. +91-80-30280124

SALES COMPANIES AND REPRESENTATIVE OFFICES:**FINLAND****Helsinki**

Vacon Plc
Äyritie 8
01510 Vantaa
telephone: +358 (0)201 212 600
fax: +358 (0)201 212 699

Tampere

Vacon Plc
Vehnämyllynkatu 18
33580 Tampere
telephone: +358 (0)201 2121
fax: +358 (0)201 212 750

AUSTRALIA

Vacon Pacific Pty Ltd
5/66-74, Micro Circuit
Dandenong South, VIC 3175
telephone: +61 (0)3 9238 9300
fax: +61 (0)3 92389310

AUSTRIA

Vacon AT Antriebssysteme GmbH
Aumühlweg 21
2544 Leobersdorf
telephone: +43 2256 651 66
fax: +43 2256 651 66 66

BELGIUM

Vacon Benelux NV/SA
Interleuvenlaan 62
3001 Heverlee (Leuven)
telephone: +32 (0)16 394 825
fax: +32 (0)16 394 827

BRAZIL

Vacon Brazil
Alameda Mamoré, 535
Alphaville - Barueri -SP
Tel. +55 11 4166-5707
Fax. +55 11 4166-5567

CANADA

Vacon Canada
221 Griffith Road
Stratford, Ontario N5A 6T3
telephone: +1 (519) 508-2323
fax: +1 (519) 508-2324

CHINA

Vacon Suzhou Drives Co. Ltd.
Beijing Branch
A528, Grand Pacific Garden Mansion
8A Guanghua Road
Beijing 100026
telephone: +86 10 51280006
fax: +86 10 65813733

CZECH REPUBLIC

Vacon s.r.o.
Kodanska 1441/46
110 00 Prague 10
telephone: +420 234 063 250
fax: +420 234 063 251

FRANCE

Vacon France
ZAC du Fresne
1 Rue Jacquard - BP72
91280 Saint Pierre du Perray CDIS
telephone: +33 (0)1 69 89 60 30
fax: +33 (0)1 69 89 60 40

GERMANY

Vacon GmbH
Gladbecker Strasse 425
45329 Essen
telephone: +49 (0)201 806 700
fax: +49 (0)201 806 7099

Vacon OEM Business Center GmbH

Industriestr. 13
51709 - Marienheide
Germany
Tel. +49 02264 17-17
Fax. +49 02264 17-126

INDIA

Vacon Drives & Control Plc
Plot No 352
Kapaleeshwar Nagar
East Coast Road
Neelangarai
Chennai-600041
Tel. +91 44 244 900 24/25

ITALY

Vacon S.p.A.
Via F.lli Guerra, 35
42100 Reggio Emilia
telephone: +39 0522 276811
fax: +39 0522 276890

THE NETHERLANDS

Vacon Benelux BV
Weide 40
4206 CJ Gorinchem
telephone: +31 (0)183 642 970
fax: +31 (0)183 642 971

NORWAY

Vacon AS
Bentsrudveien 17
3080 Holmestrand
telephone: +47 330 96120
fax: +47 330 96130

ROMANIA

Vacon Romania - Reprezentanta
Cuza Voda 1
400107 Cluj Napoca
Tel. +40 364 118 981
Fax. +40 364 118 981

RUSSIA

ZAO Vacon Drives
Ul. Letchika Babushkina 1,
Stroenie 3
129344 Moscow
telephone: +7 (495) 363 19 85
fax: +7 (495) 363 19 86

ZAO Vacon Drives
2ya Sovetskaya 7, office 210A
191036 St. Petersburg
telephone: +7 (812) 332 1114
fax: +7 (812) 279 9053

SLOVAKIA

Vacon s.r.o. (Branch)
Seberiniho 1
821 03 Bratislava
Tel. +421 243 330 202
Fax. +421 243 634 389

SPAIN

Vacon Drives Ibérica S.A.
Miquel Servet, 2. P.I. Bufalvent
08243 Manresa
telephone: +34 93 877 45 06
fax: +34 93 877 00 09

SWEDEN

Vacon AB
Anderstorpsvägen 16
171 54 Solna
telephone: +46 (0)8 293 055
fax: +46 (0)8 290 755

THAILAND

Vacon South East Asia
335/32 5th-6th floor
Srinakarin Road, Prawet
Bangkok 10250
Tel. +66 (0)2366 0768

UKRAINE

Vacon Drives Ukraine (Branch)
42-44 Shovkovychna Str.
Regus City Horizon Tower
Kiev 01601, Ukraine
Tel. +380 44 459 0579
Fax +380 44 490 1200

UNITED ARAB EMIRATES

Vacon Middle East and Africa
Block A, Office 4A 226
P.O.Box 54763
Dubai Airport Free Zone
Dubai
Tel. +971 (0)4 204 5200
Fax: +971 (0)4 204 5203

UNITED KINGDOM

Vacon Drives (UK) Ltd.
18, Maizefield
Hinckley Fields Industrial Estate
Hinckley
LE10 1YF Leicestershire
telephone: +44 (0)1455 611 515
fax: +44 (0)1455 611 517

UNITED STATES

Vacon, Inc.
3181, Black Gap Road
Chambersburg, PA 17202
telephone: +1 (877) 822-6606
fax: +1 (717) 267-0140

