



## INSTRUCTIONS INSTALLATION OF TOP SECTION BACK-CHANNEL COOLING KIT FOR FRAMES D3, D4 & E2

This instruction sheet is for the installation of the top section only of the back-channel cooling kits available for the VLT® series drives. In addition to the enclosure a 200 mm vented pedestal is required.

The minimum enclosure depth is 500 mm (600 mm for E2 frame) and the minimum enclosure width is 600 mm (800 mm for E2 frame). The maximum depth and width are as required by the installation. When using multiple drives in one enclosure mount each drive on its own back panel and support along the mid-section of the panel. The back-channel cooling kits are very similar in construction for all frames. The D3 and D4 kits do not support “in frame” mounting of the drives. The E2 kit is mounted “in frame” for additional support of the drive. These kits can be used with IP00/Chassis drives as listed in Table 1.

Using these kits as described removes 85% of the losses via the back channel using the drive’s main heat sink fan. The remaining 15% must be removed via the door of the enclosure. (Refer to Note 2 for air flow requirements.)

Table 1. Applicable Drives and Frames

VLT Drive	Frame
HVAC	D3, D4, E2
Aqua	D3, D4, E2
Automation	D3, D4, E2

Table 2. Kit Part Numbers

VLT Frame	Kit Part Number
D3 and D4	176F1775
E2	176F1776

Notes:

1. The photos in this instruction are based on a D4 Frame installation. D3 and E2 frames use parts similar to those in the photos however they are sized appropriately for those frames.
2. A doorfan(s) is required on the enclosure to remove the heat losses not contained in the backchannel of the drive. The minimum airflow required (at the maximum rated ambient temperature) for the D3 and D4 frame drives is 391 m<sup>3</sup>/h (230 cfm). The minimum airflow required (at the maximum rated ambient temperature) for the E2 frame drive is 782 m<sup>3</sup>/h (460 cfm). If additional heat losses are added within the enclosure a calculation must be made to ensure the proper airflow is provided to cool the inside of the enclosure.
3. The end user is responsible for ensuring the enclosure rating of the system after the top-only duct kit is installed.

### **Kit Contents**

- Ductwork components
- Mounting hardware
- Gasket material
- 175R5631 View of Ductwork components, D3 and D4 frames
- 175R1037 View of Ductwork components, E2 frame

### **Required Tools**

- Metric Socket Set, 7-19mm
- Socket Extensions
- Torx Driver Set T10-T40
- Torque Wrench 6-50 in-lbs (.7-6 N-M)

### **Torque Requirements**

1. 10 mm, M5 Nuts torque to 20 in-lbs (2.3 N-M)
2. T25 Torx screws torque to 20 in-lbs (2.3 N-M)

Install gasket material on the back openings of the drive (Photo 1) prior to installation on the enclosure back panel.

D3 and D4 frames: Use the template provided with the kit (175R5639) to determine the drive location on the back panel of the enclosure. The template is referenced to the top-left corner of the back panel. Therefore the template may be used with any size back panel and both the 1800 mm and 2000 mm high enclosures.

E2 frame: Use the measurements on Drawing 175R1037, Sheet 2 to determine the drive location.



Photo 1. Drive openings on rear are not used in this application.

Prior to installing the back panel in the enclosure, apply the gasket on both sides of the bottom duct adapter as shown in Photos 2 and 3.

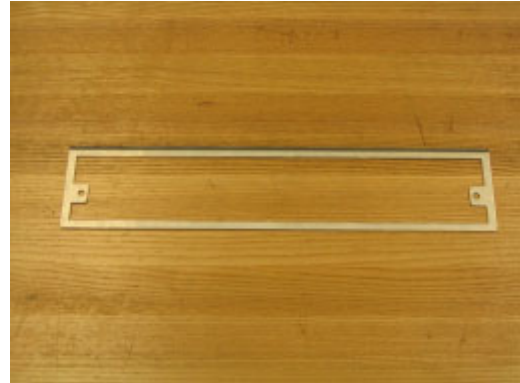

Photo 2. Bottom duct adapter



Photo 3. Bottom duct adapter w/

Before installing the back panel with the drive in the enclosure, remove and discard the rear-most screws (Photo 4) that are located on the top cover of the drive. The holes will be used to fasten the top ductwork with longer screws provided with the kit.

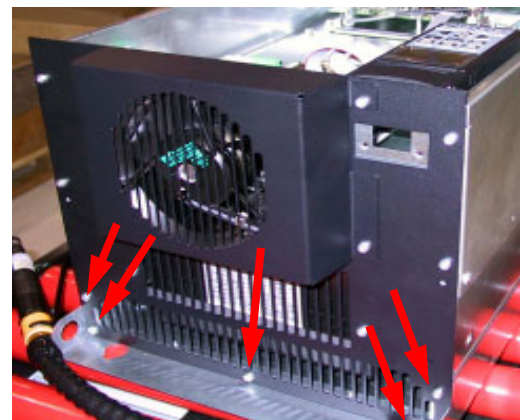

Photo 4. Top of IP00/Chassis drive.

Install the backpanel in the enclosure (Photo 5). Use brackets supplied by the enclosure manufacturer (minimum one per side at the middle of the drive) with appropriate support strip for additional support of the backpanel. For the D4 frame use two supports per side. Consult the enclosure manufacturer manual for additional support requirements if additional components are mounted on the same back panel.



Photo 5. Drive installed in cabinet—D4 Frame.

The top duct work cover is composed of the following pieces as shown in Photo 6.

From left to right:

- top duct closing plate
- drive bracket
- duct
- vented top cover

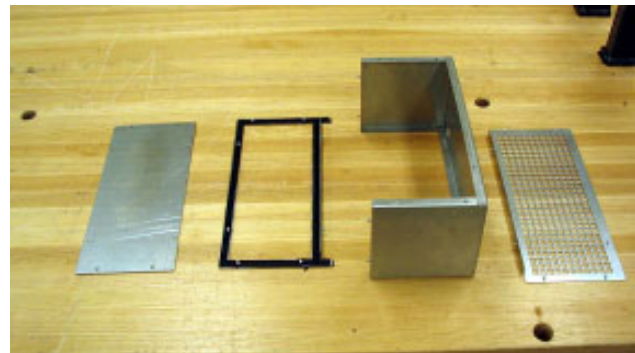

Photo 6. Top duct assembly.

Install the drive bracket onto the duct.



Photo 7. The top duct work partially assembled with bottom flange.

Temporarily install the top duct section as shown in Photo 8. Use the top duct cover piece to mark the enclosure top for the opening. Alternately, Drawing 175R5639 can be used to mark the enclosure for cut-



Photo 8. Top duct work and enclosure top installed.

Cut the enclosure top. Do not apply gasket to enclosure top (the gasket is part of the duct work).



Photo 9. Enclosure top with cutout.

Assemble the top duct as shown in Photos 10, 11 and 12. Gasket is applied to several surfaces as shown (refer to drawing 175R5631 Sheet 2, exploded view of components). The top duct closing plate is left off for the installation of the duct work on the drive.

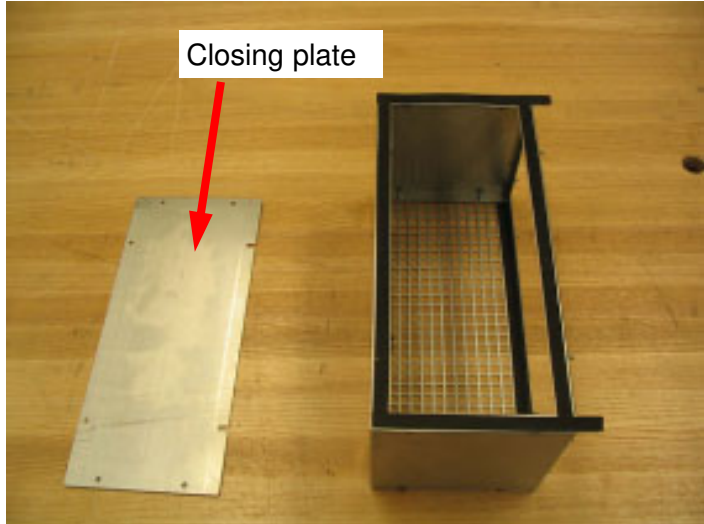

Photo 10. Top duct assembled with gasket.

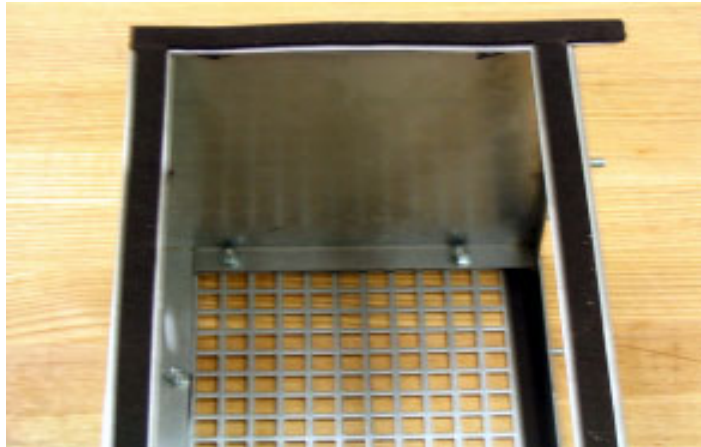

Photo 11. Gasket applied to both sides drive bracket and grated cover.

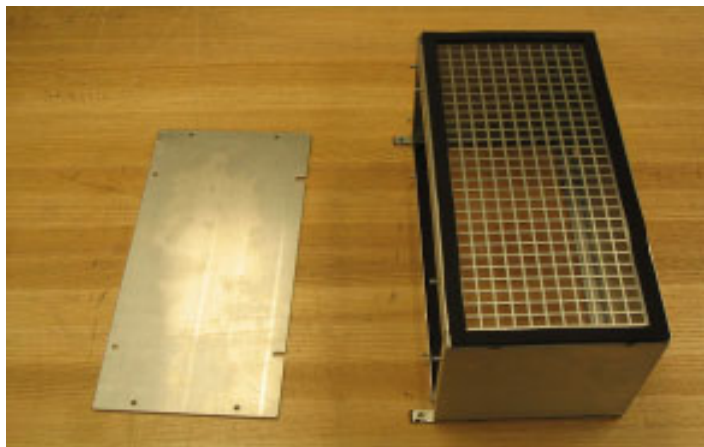

Photo 12. Top duct ready to be installed on drive.

The top duct work is attached to the drive using existing holes on the top cover of the drive. Use the 5 longer screws (supplied with kit) to install the top duct work. The duct work will fit over the drive mounting bolts.

Once the duct work is attached to the drive, the duct closing plate can be attached. The top duct work assembly is complete.



Photo 13. Gasket folds over the edge to form seal between the duct and top vented cover.



Photo 14. Top duct installed.

Install top duct-cover assembly using the longer T25 screws provided with the kit in the drive top cover holes. Reference Photos 15.



Photo 15. Top duct installed.

Apply the gasket to the top duct closing plate. Reference Photo 16.



Photo 16. Top duct closing plate with gasket.

Install the duct closing plate. Reference Photo 17.

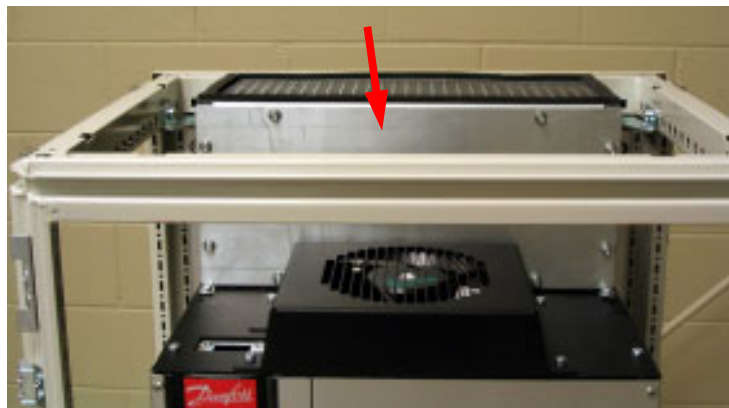

Photo 17. Top duct closing plate installed.



Install the top of the enclosure. Reference Photos 18 and 19.

Top duct installation is complete.



Photo 18. Enclosure top installed.



Photo 19. Top view of enclosure.

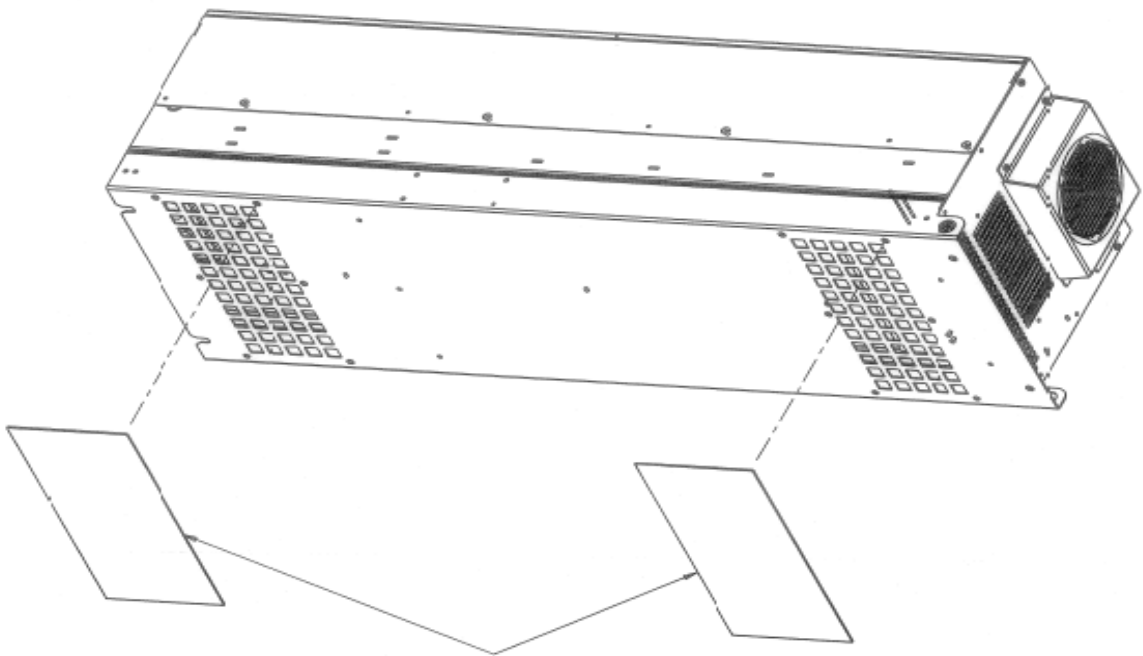

GASPERED TO COVER VENT GRIDS  
ON THE BACK OF THE DRIVE

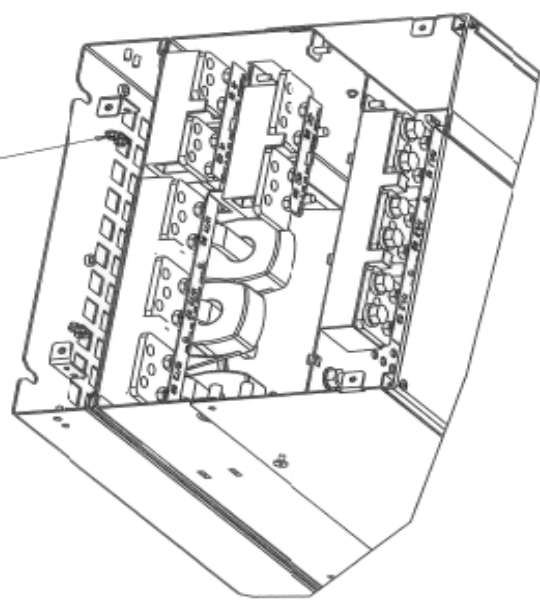

4X M5 NUTS

THIS DOCUMENT CONTAINS UNCLASSIFIED INFORMATION OF DEFENSE INTEREST. IT IS HEREBY AUTHORIZED FOR RELEASE TO THE PUBLIC ON THE CONDITION THAT IF AND WHEN ANY INFORMATION IS DISCLOSED TO THE PUBLIC, THE SOURCE OF THE INFORMATION SHALL NOT BE DISCLOSED TO THE PUBLIC. THIS DOCUMENT IS UNCLASSIFIED EXCEPT WHERE SHOWN OTHERWISE IN A NOTICE ON THIS DOCUMENT. UNCLASSIFIED INFORMATION IS IDENTIFIED BY THE MARKING "UNCLASSIFIED" AND SHALL BE REMOVED FROM FUTURE EDITIONS OF THIS DOCUMENT.		DATE OF REVIEW: 9/20/04 REVIEWED BY: [Signature] DATE: 9/20/04		DATE OF REVIEW: 9/20/04 REVIEWED BY: [Signature] DATE: 9/20/04	
HP08010	PART NO.	MN 0128108	PART NAME	NONE	NONE
11585631	13	11585631	13	11585631	A

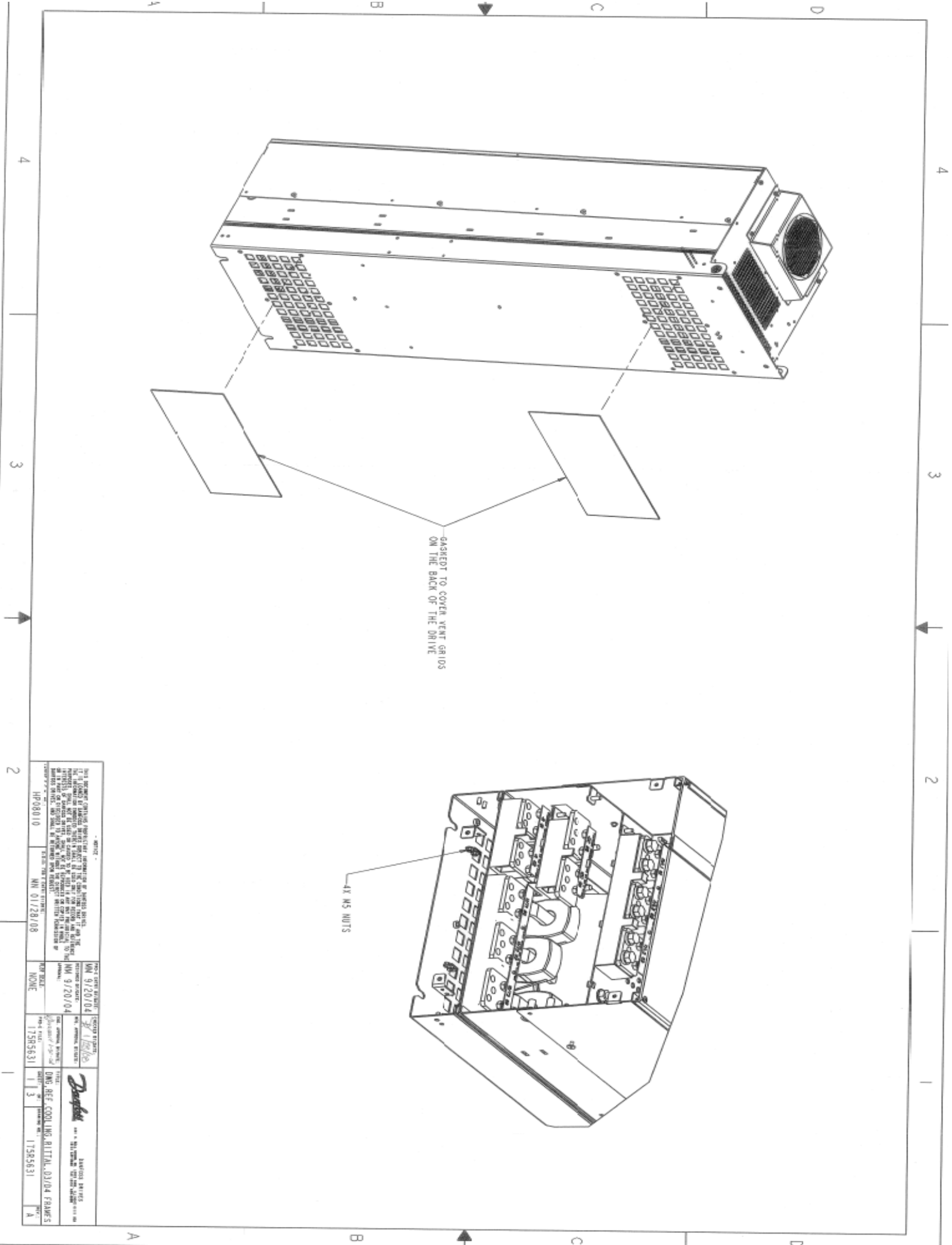

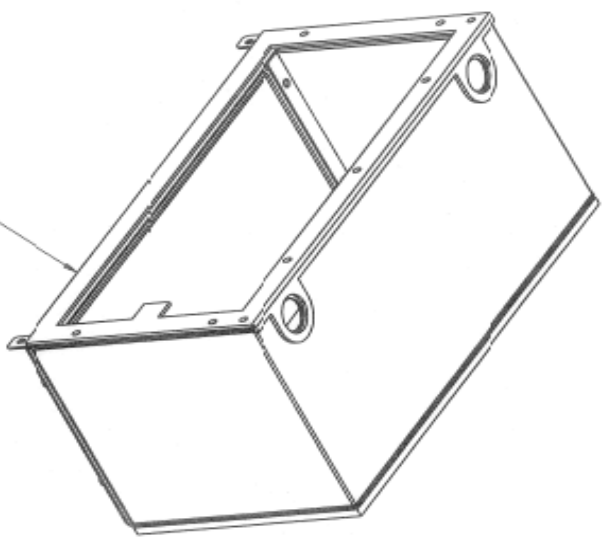
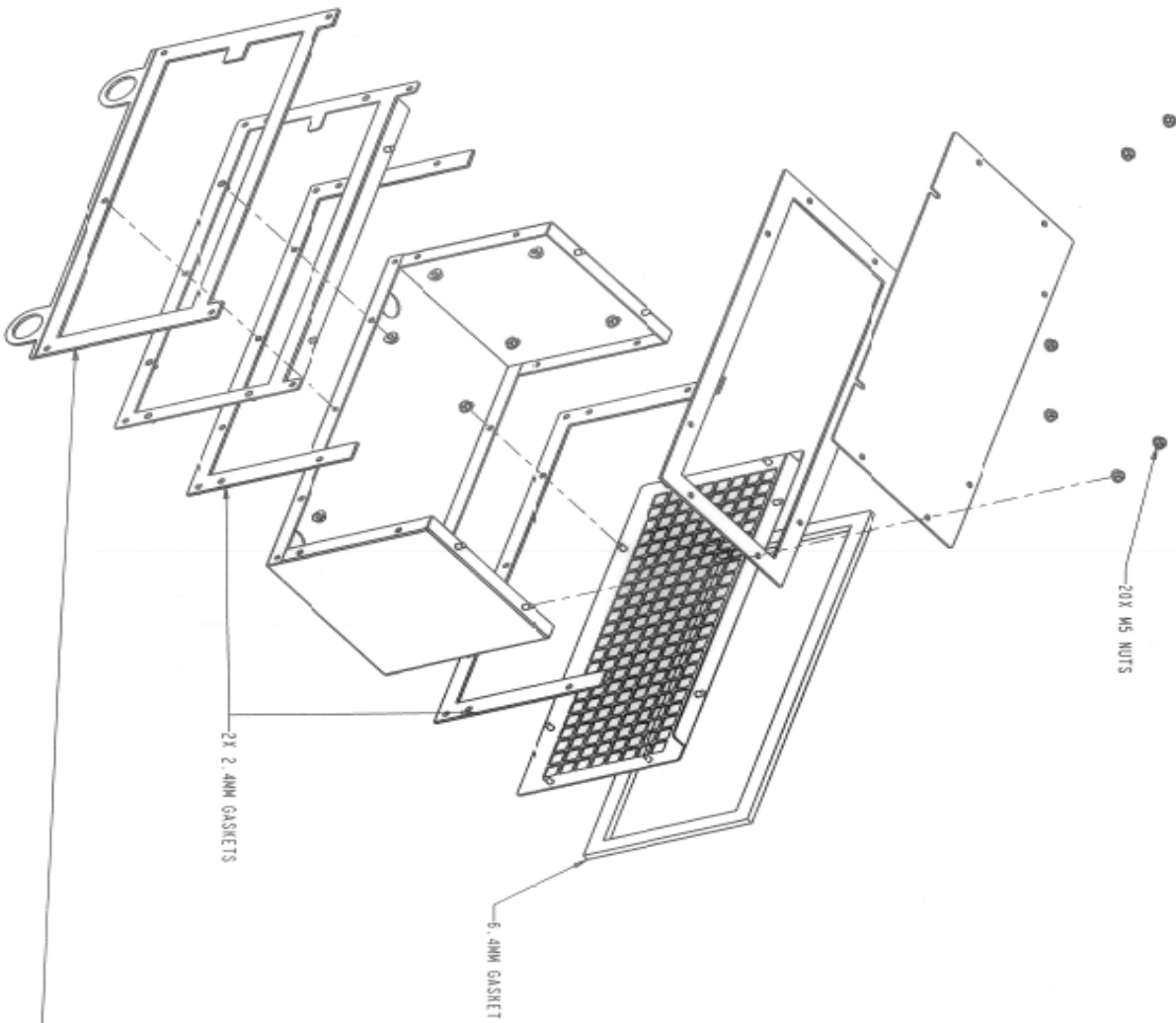

CORRECT APPLICATION OF 2.4MM GASKET

4

3

2

PROJECT NO.	DATE	BY	CHKD.	APP'D.
HP08010	01/28/08	None	1158631	2/3
DWG. REF. COOLING RITTL, 03/04, FRANCIS				
A				

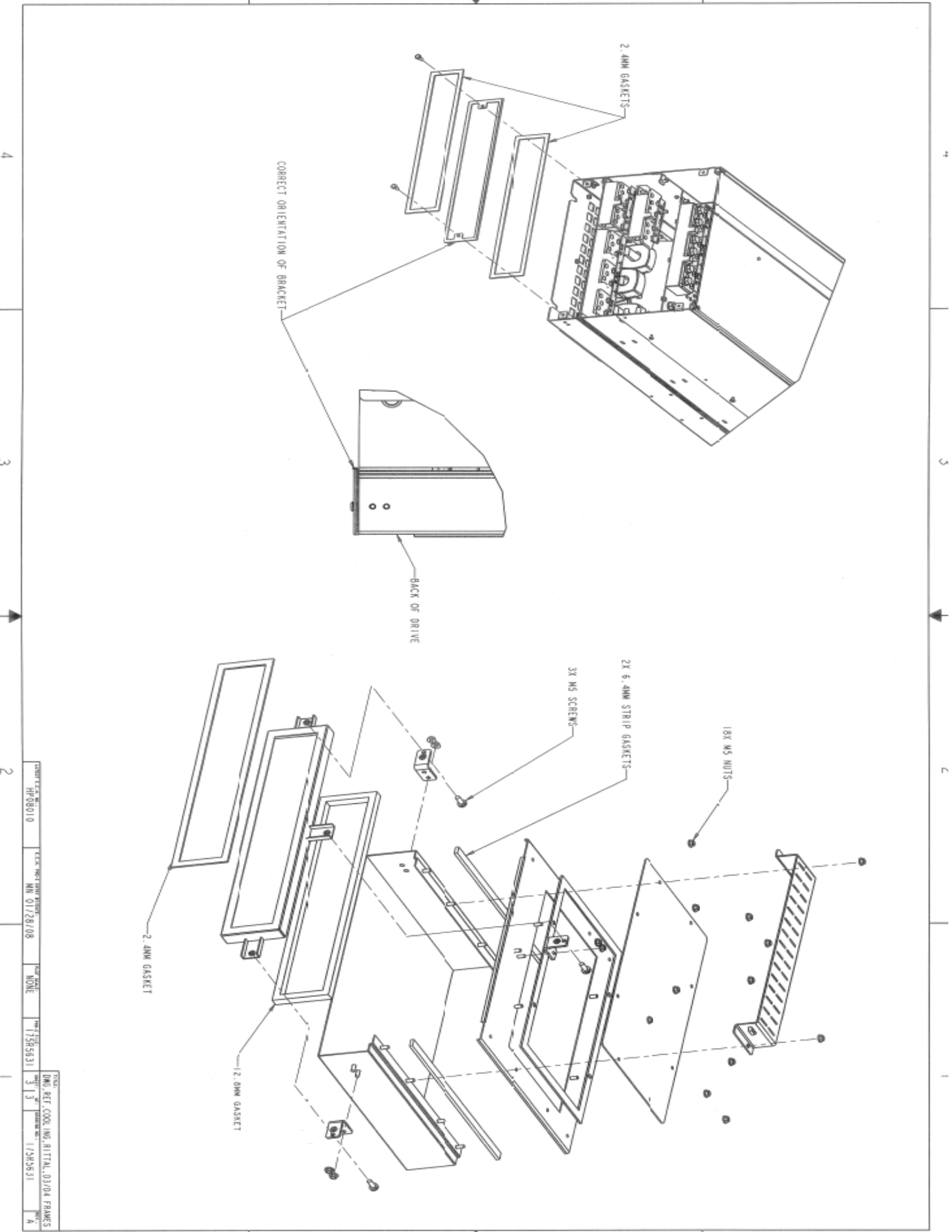

DESIGN NO.	REV.	DATE	BY	CHKD.	APP.
HP08010	3	01/28/08			
DESCRIPTION	REV.	DATE	BY	CHKD.	APP.
DRIVE REF COOLING INITIAL 03/04 FRAMES	3	01/28/08			
REV. 1	3				
REV. 2					
REV. 3					
REV. 4					
REV. 5					
REV. 6					
REV. 7					
REV. 8					
REV. 9					
REV. 10					
REV. 11					
REV. 12					
REV. 13					
REV. 14					
REV. 15					
REV. 16					
REV. 17					
REV. 18					
REV. 19					
REV. 20					

ENCLOSURE TOP PLATE TO BE MODIFIED

3

2

1

SEE DETAIL B

RITTAL TSB ENCLOSURE  
HEIGHT: 2000MM OR 2200MM  
WIDTH: 800MM MIN  
DEPTH: 600MM MIN

RITTAL MOUNTING PANEL  
TO BE MODIFIED  
(PANEL MUST BE MOUNTED  
INSIDE FRAME FOR 600MM DEEP  
CABINETS)

ENCLOSURE BOTTOM GLAND  
PLATE TO BE MODIFIED

336.0

164.0

LOWER DUCT ASSEMBLY MUST BE INSTALLED BEHIND SHEET METAL FLANGE

DETAIL A  
SCALE 0.750

UPPER DUCT ASSEMBLY

SEE DETAIL A

LOWER DUCT ASSEMBLY

DETAIL B  
SCALE 2.000

BRACKET TO SECURE  
CENTER OF TOP CUTOUT

M5 X 0.0 NUT

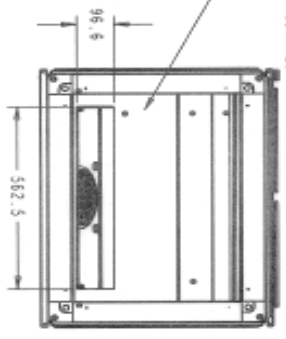
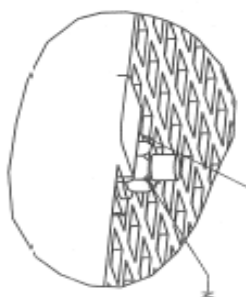
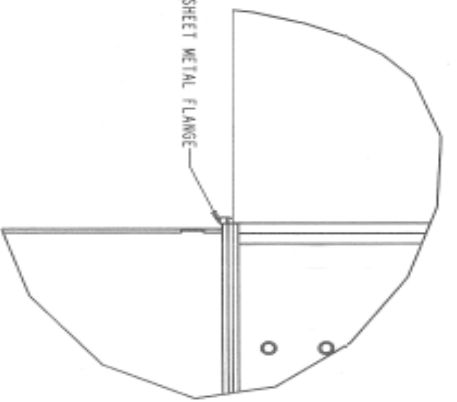
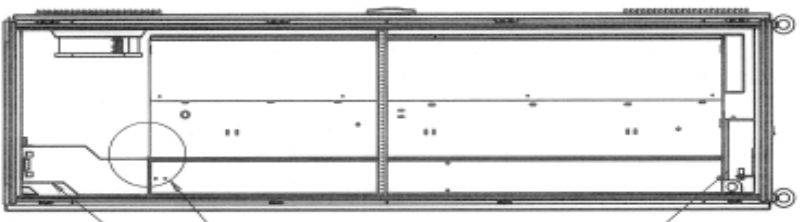
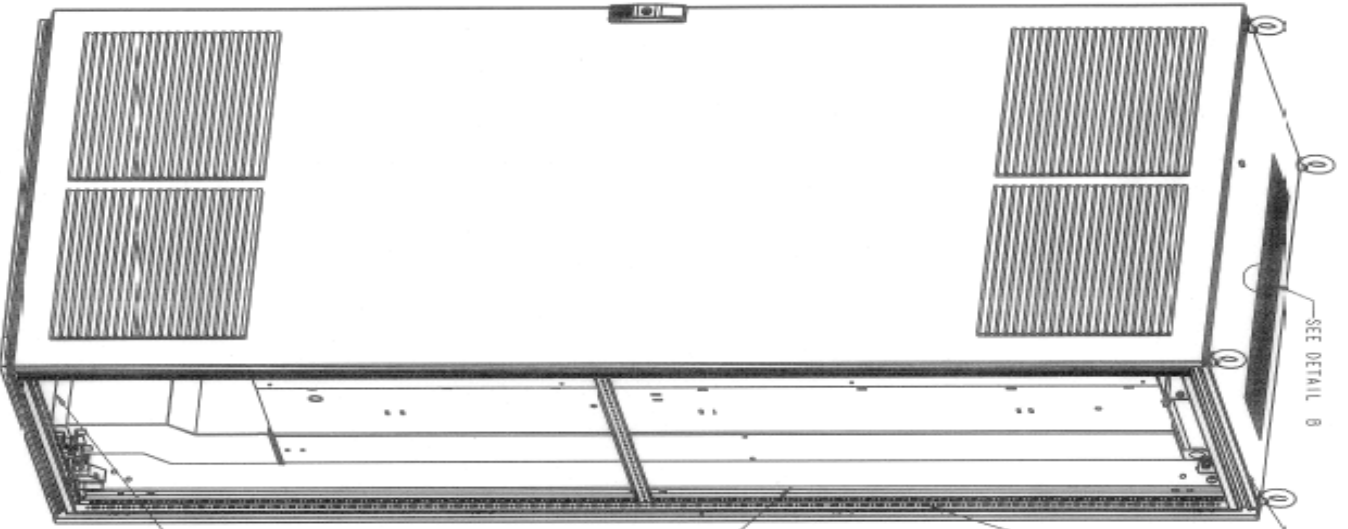

NOTES:		DATE: 01/11/05		DRAWN: J. J. J.	
THIS DRAWING CONTAINS INFORMATION PROPRIETARY TO THE COMPANY AND IS NOT TO BE REPRODUCED OR TRANSMITTED IN ANY FORM OR BY ANY MEANS, ELECTRONIC OR MECHANICAL, INCLUDING PHOTOCOPYING, RECORDING, OR BY ANY INFORMATION STORAGE AND RETRIEVAL SYSTEM, WITHOUT THE WRITTEN PERMISSION OF THE COMPANY.		DATE: 01/11/05		DRAWN: J. J. J.	
PROJECT: HP 000010		DATE: 01/28/08		DRAWN: J. J. J.	
SCALE: NONE		DATE: 1/28/03		DRAWN: J. J. J.	
PROJECT: HP 000010		DATE: 1/28/03		DRAWN: J. J. J.	
SCALE: NONE		DATE: 1/28/03		DRAWN: J. J. J.	
PROJECT: HP 000010		DATE: 1/28/03		DRAWN: J. J. J.	
SCALE: NONE		DATE: 1/28/03		DRAWN: J. J. J.	
PROJECT: HP 000010		DATE: 1/28/03		DRAWN: J. J. J.	
SCALE: NONE		DATE: 1/28/03		DRAWN: J. J. J.	

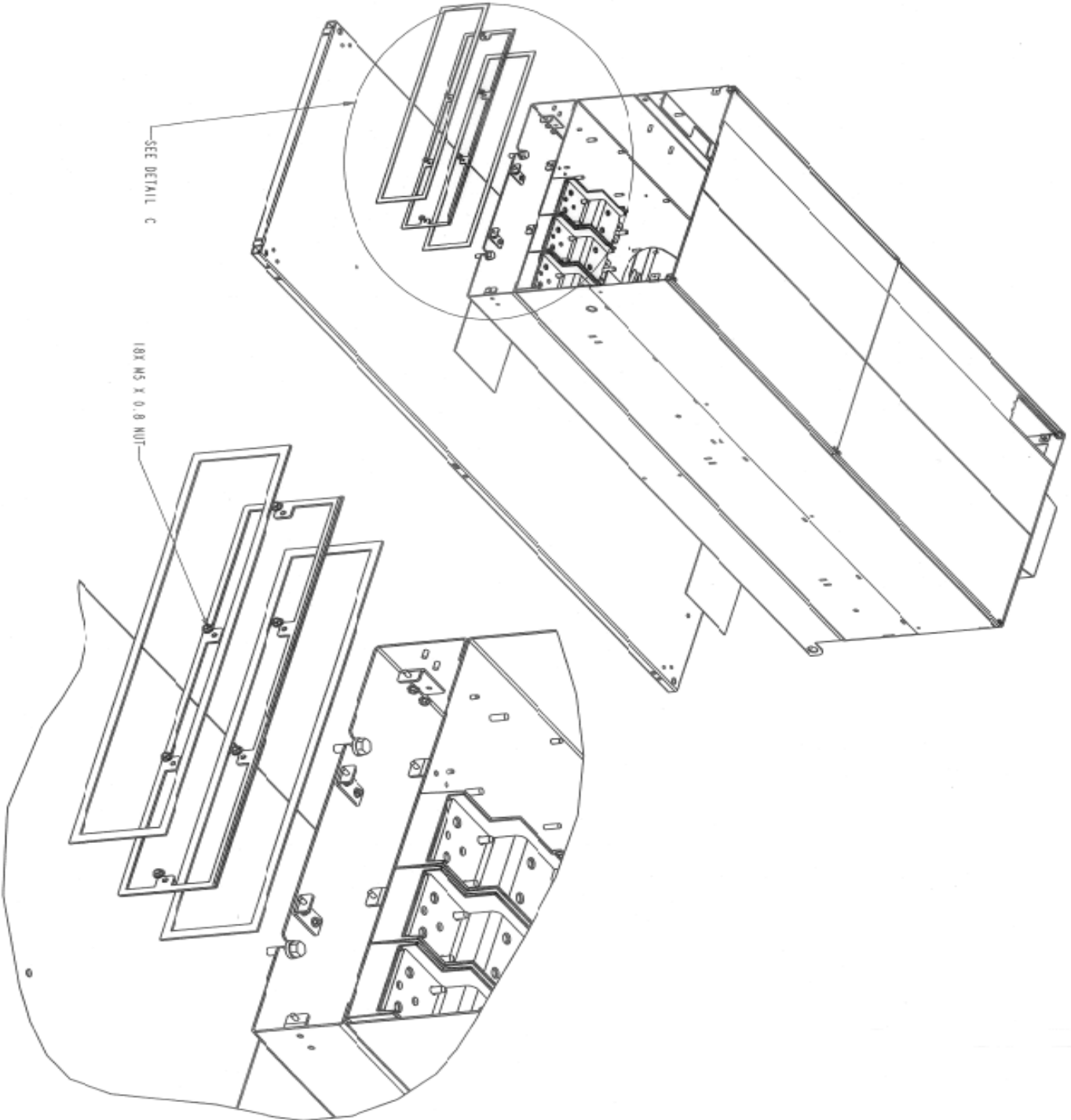

DETAIL C  
SCALE 0.400

PROJECT NO.	DATE	BY	CHKD BY	APP'D BY	SCALE
11008010	01/28/08	MM	MM	MM	0.400
TITLE: DMG REF. COOLING RITIAL E2					
DRAWING NO. 11581037					
SHEET NO. 2 OF 3					

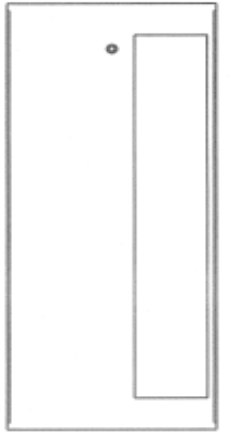

RITTAL BOTTOM PANEL

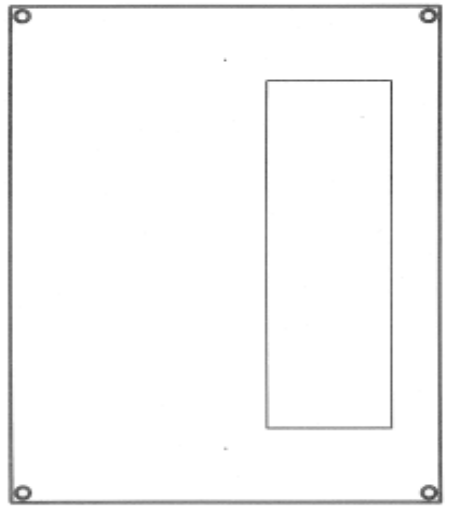

RITTAL TOP COVER

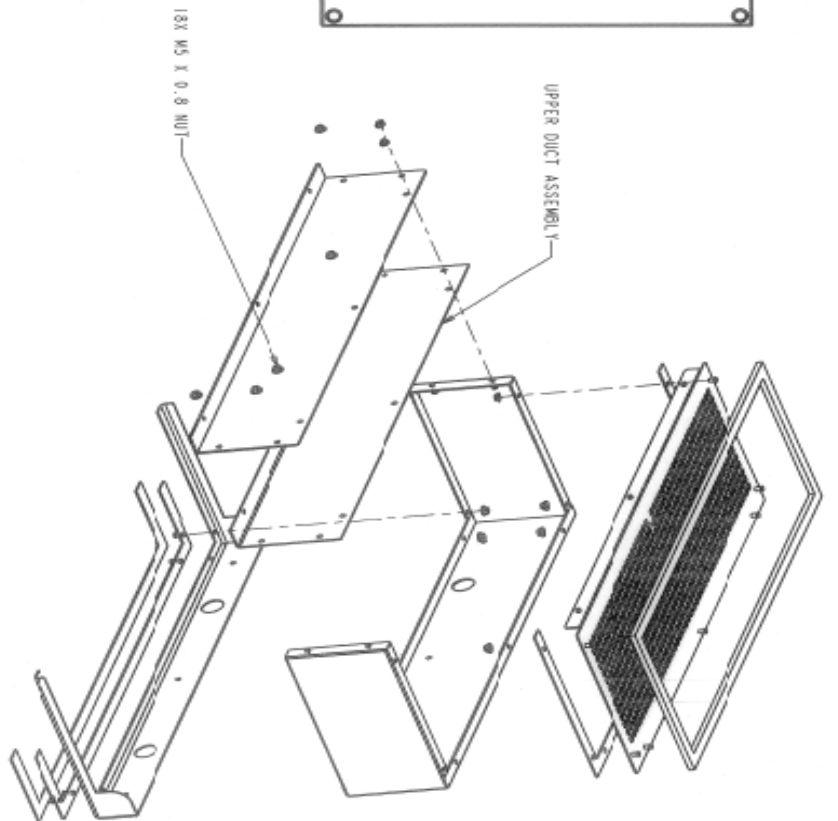

UPPER DUCT ASSEMBLY

1/8 X M5 X 0.8 NUT

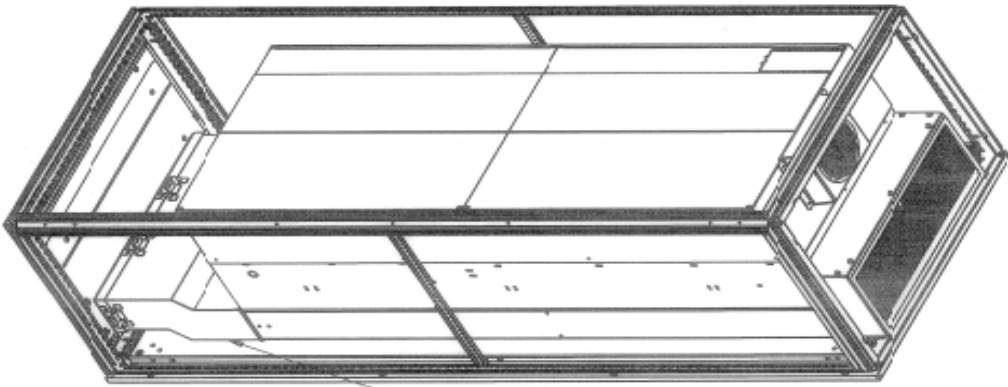

LOWER DUCT ASSEMBLY

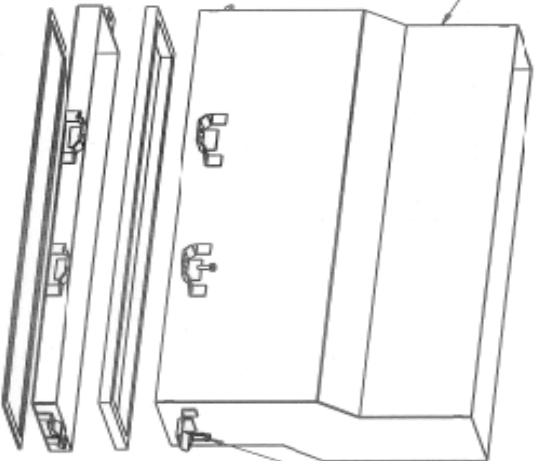

4 X M5 X 16MM TORX SCREW

DURING INSTALLATION SET SCREW TO BE MOVED TO OUTER POSITION AND TIGHTENED.

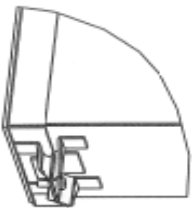

TO COMPLETE INSTALLATION OF LOWER DUCT, SET SCREW MOVED TO INNER POSITION AND TIGHTENED.

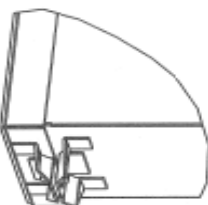

CONTRACT NO.	T.C. INSTRUMENTS	DATE	REV.	DATE	REV.	TITLE
HP98010	MM 01/28/08	NONE	11581037	3	3	DWG. REF. COOLING RITTAL, E2
						REV. 8