

Installation Instructions

Memory Module Replacement

VLT[®] DriveMotor FCP 106 & FCM 106

Introduction

The instructions provide information about the replacement of memory module (ordering number: 134B0791).

A memory module is a component that stores motor and pump data, as well as firmware and parameter settings of a frequency converter. If a frequency converter malfunctions, the motor and pump data, firmware, and parameter settings on this frequency converter can be copied to new frequency converters of the same power sizes. Doing this saves the time for setting up the frequency converters for the same applications.

A memory module is pre-installed on the frequency converter. The data and parameter settings on a memory module are encoded files that are protected from direct viewing.

To access files in a memory module, or transfer files between a memory module and a PC, a memory module programmer is required. It is not included in this package and needs to be ordered separately (ordering number: 134B0792).

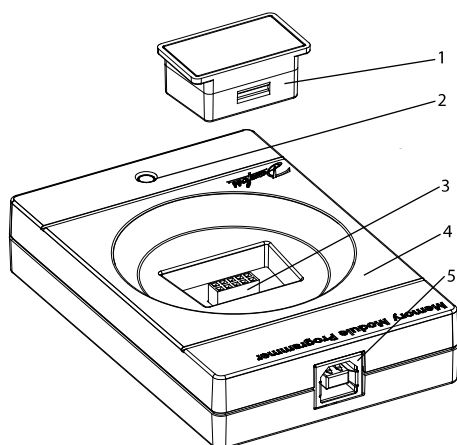

130BE109.11

1	Memory module
2	Status indicator light
3	Socket for memory module
4	Memory module programmer
5	USB Type-B receptacle

Illustration 1.1 Memory Module and Memory Module Programmer

Items Supplied

Ordering number	Items supplied
134B0791	Memory module

Safety Instructions

Only qualified personnel is allowed to install or operate this equipment. Qualified personnel is defined as trained staff, who are authorised to install, commission, and maintain equipment, systems and circuits in accordance with pertinent laws and regulations. Additionally, the personnel must be familiar with the instructions and safety measures described in the *operating instructions*.

⚠ WARNING

DISCHARGE TIME

The frequency converter contains DC-link capacitors, which can remain charged even when the frequency converter is not powered. High voltage can be present even when the warning LED indicator lights are off. Failure to wait the specified time after power has been removed before performing service or repair work can result in death or serious injury.

- Stop the motor.
- Disconnect AC mains and remote DC-link power supplies, including battery back-ups, UPS, and DC-link connections to other frequency converters.
- Disconnect or lock PM motor.
- Wait for the capacitors to discharge fully. The minimum duration of waiting time is specified in *Table 1.1*.
- Before performing any service or repair work, use an appropriate voltage measuring device to make sure that the capacitors are fully discharged.

Voltage [V]	Power range [kW (hp)]	Minimum waiting time (minutes)
380–480	0.55–7.5 (0.75–10)	4

Table 1.1 Discharge Time

Memory Module Replacement

Tools required

- Torx 20 screwdriver

Complete the following steps to replace the memory module:

1. Stop the motor and the frequency converter, and wait for the capacitors to discharge completely. The discharge time is specified in *Table 1.1*.
2. Remove the front cover. Refer to the *operating instructions* for instructions of removing the front cover.
3. Remove the memory module from the frequency converter, as shown in *Illustration 1.2*.
4. If applicable, transfer files to the new memory module. Refer to the *Memory Module Programmer Installation Instructions* for details.
5. Install the new memory module.
6. Mount the front cover. Refer to the *operating instructions* for instructions of mounting the front cover.
7. When the frequency converter powers up, the data on the memory module is downloaded to the frequency converter and takes effect.

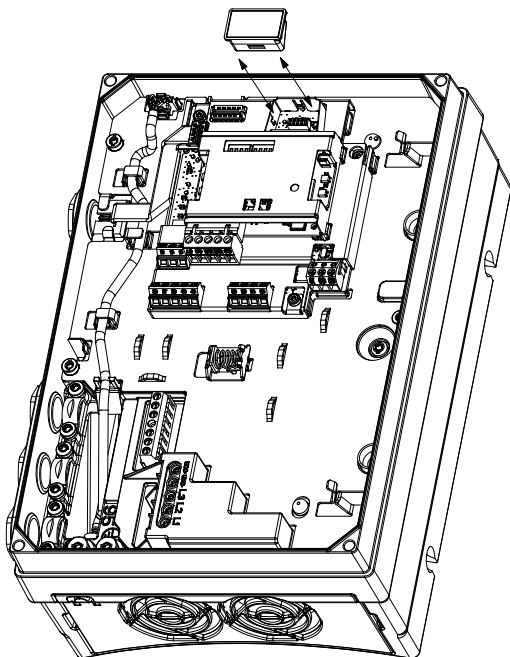

130BE108.11

Illustration 1.2 Remove the Memory Module from the Frequency Converter

.....
Danfoss can accept no responsibility for possible errors in catalogues, brochures and other printed material. Danfoss reserves the right to alter its products without notice. This also applies to products already on order provided that such alterations can be made without subsequential changes being necessary in specifications already agreed. All trademarks in this material are property of the respective companies. Danfoss and the Danfoss logotype are trademarks of Danfoss A/S. All rights reserved.
.....

