

In-bottom/Out-back Cooling Kit for FA11-FA12 iC7 Series Frequency Converters

1 Overview

1.1 Description

The in-bottom/out-back cooling kit fits FA11 and FA12 frequency converters mounted in Rittal TS8 cabinets with widths of 600 mm (24 in) or 800 mm (32 in). When the kit is installed, air flows into the bottom duct and out through the back duct of the frequency converter. See [Illustration 1](#).

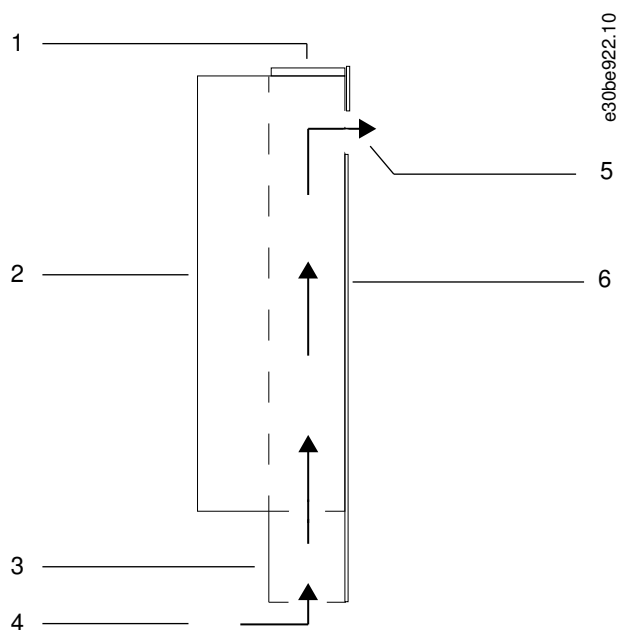

Illustration 1: Direction of Airflow with Kit Installed

1	Top cover	4	Back channel airflow (intake)
2	Frequency converter	5	Back channel airflow (exhaust)
3	Bottom duct assembly	6	Mounting plate

1.2 Kit Numbers

Use these instructions with the following kits.

Table 1: In-bottom/Out-back Cooling Kits

Number	Kit description
176F4059	In-bottom/out-back cooling kit for FA11 in 600 mm (24 in) cabinet
176F4193	In-bottom/out-back cooling kit for FA11 in 800 mm (32 in) cabinet
176F4060	In-bottom/out-back cooling kit for FA12 in 800 mm (32 in) cabinet

1.3 Items Supplied

The following parts are contained in the kit.

Table 2: Items Supplied in In-bottom/Out-back Cooling Kits

Item	Quantity
Top cover	1
Top gasket	1
Duct support bracket	1
Duct support gasket	1
Telescopic bottom duct	1
Ribbed EPDM rubber seal	1
Base plate (with opening for duct)	1
Back duct	1
6-hole back gasket	2
8-hole back gasket	2
M5x18 screw	12
M5x14 screw	8
M5 hex nut	6
M6x12 screw	6
M5 clip-on nut	8

2 Installation

2.1 Safety Information

NOTICE

QUALIFIED PERSONNEL

Only qualified, Danfoss authorized personnel are allowed to install the parts described in these installation instructions.

- Disassembly and reassembly of the frequency converter must be done in accordance with the service guide.
- Use the standard fastener torque values from the service guide, unless the torque value is specified in these instructions.

⚠ WARNING ⚠

DISCHARGE TIME (40 MINUTES)

The frequency converter contains DC-link capacitors, which can remain charged even when the frequency converter is not powered. High voltage can be present even when the warning LED indicator lights are off. Failure to wait 40 minutes after power has been removed before performing service or repair work can result in death or serious injury.

- Stop the motor.
- Disconnect AC mains and remote DC-link power supplies, including battery back-ups, UPS, and DC-link connections to other frequency converters.
- Disconnect or lock the motor.
- Disconnect any brake option.
- Disconnect any DC connector option.
- Wait 40 minutes for the DC-link capacitors to discharge fully.
- Before performing any service or repair work, measure the voltage level to verify that the capacitors are fully discharged.

⚠ WARNING ⚠

ELECTRICAL SHOCK HAZARD

The frequency converter contains dangerous voltages when connected to mains voltage. Improper installation, and installing or servicing with power connected, can cause death, serious injury, or equipment failure.

- Only use qualified electricians for the installation.
- Disconnect the frequency converter from all power sources before installation or service.
- Treat the frequency converter as live whenever the mains voltage is connected.
- Follow the guidelines in these instructions and local electrical safety codes.

NOTICE

ELECTROSTATIC DISCHARGE

Electrostatic discharge can damage components.

- Ensure electrostatic discharge before touching internal frequency converter components, for example by touching a grounded, conductive surface or by wearing a grounded armband.

2.2 Installation Overview

NOTICE

APPLYING GASKETS

This kit contains self-adhesive gaskets to ensure a proper seal between metal parts.

- Before affixing a gasket, check that the part matches the gasket and that no holes are covered.

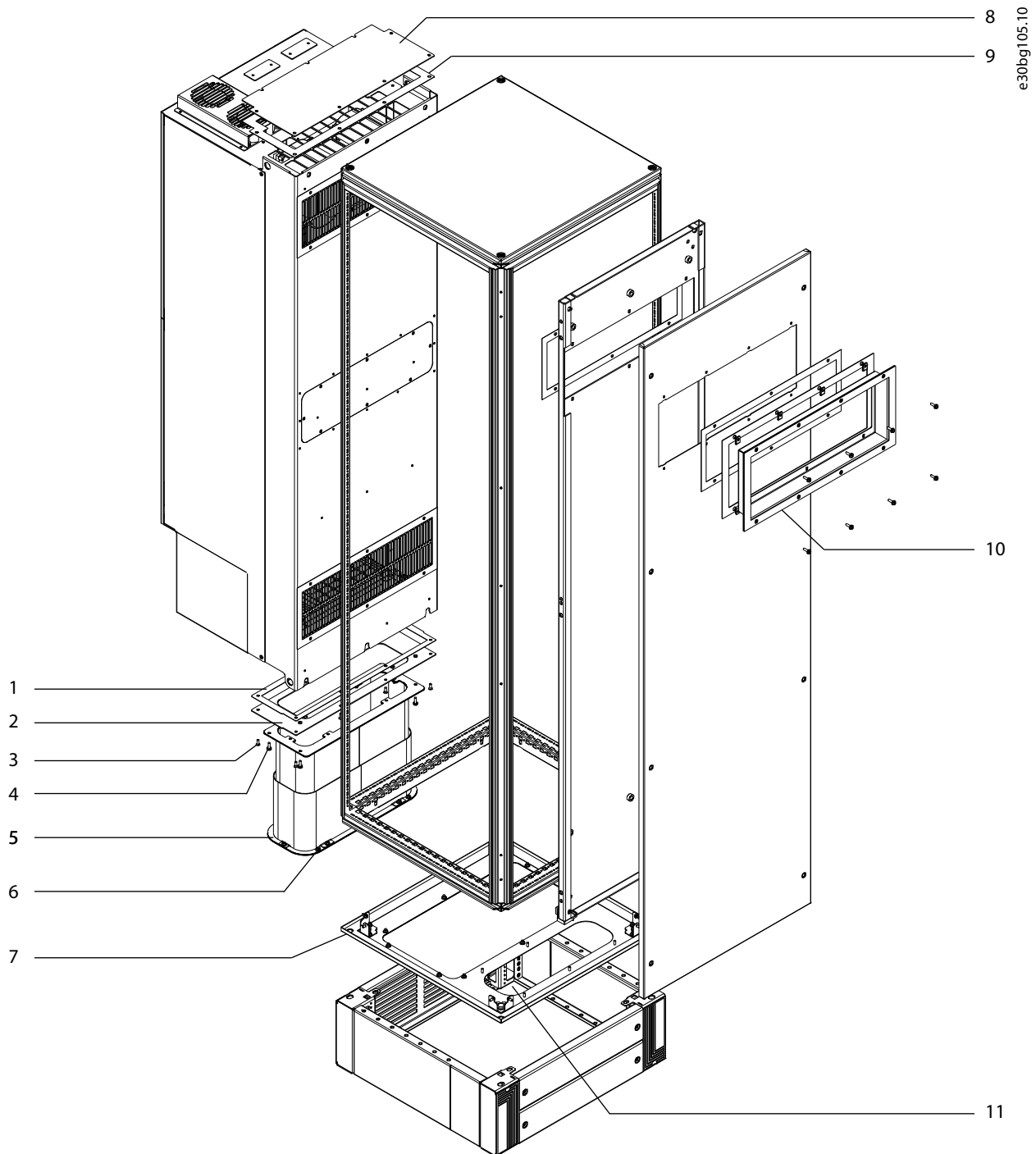

Illustration 2: Overview of In-bottom/Out-back Cooling Kit

1	Duct support gasket	7	Base plate
2	Duct support bracket	8	Top cover
3	M5x14 screw	9	Top gasket
4	M5x18 screw	10	Back duct assembly
5	Bottom duct assembly	11	Opening for duct
6	M5 hex nut		

2.3 Creating Vent Opening in the Mounting Plate

To create mounting holes and a back vent opening in the mounting plate, use the following steps. Use the dimensions in [Illustration 3](#) for FA11 frequency converters in 600 mm (24 in) cabinets, and [Illustration 4](#) for FA11 frequency converters in 800 mm (32 in) cabinets. Use the dimensions in [Illustration 5](#) for FA12 frequency converters in 800 mm (32 in) cabinets.

Procedure

1. Drill 6 mounting holes in the back of the frequency converter using the dimensions in the template.
2. Insert 6 M10 pem self-clinching nuts (not supplied) in the mounting holes.
3. Cut out the vent opening in the mounting plate using the dimensions in the template.

The opening must match the frequency converter vent opening.

4. Drill 6 screw holes around the vent opening using the dimensions in the template.

The holes must match the holes in the inner flange of the back duct.

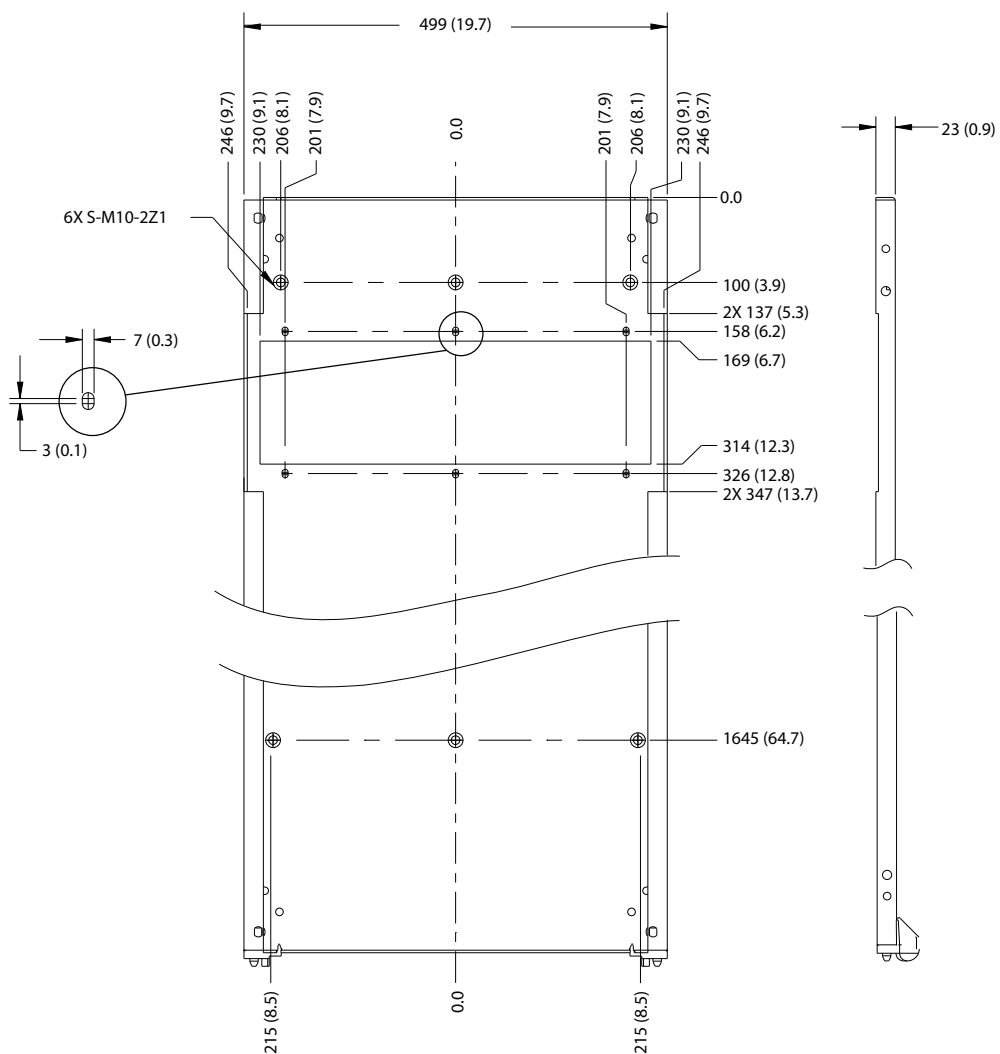

e30bg107.10

Illustration 3: Vent Dimensions for FA11 Mounting Plate in 600 mm (24 in) Cabinet

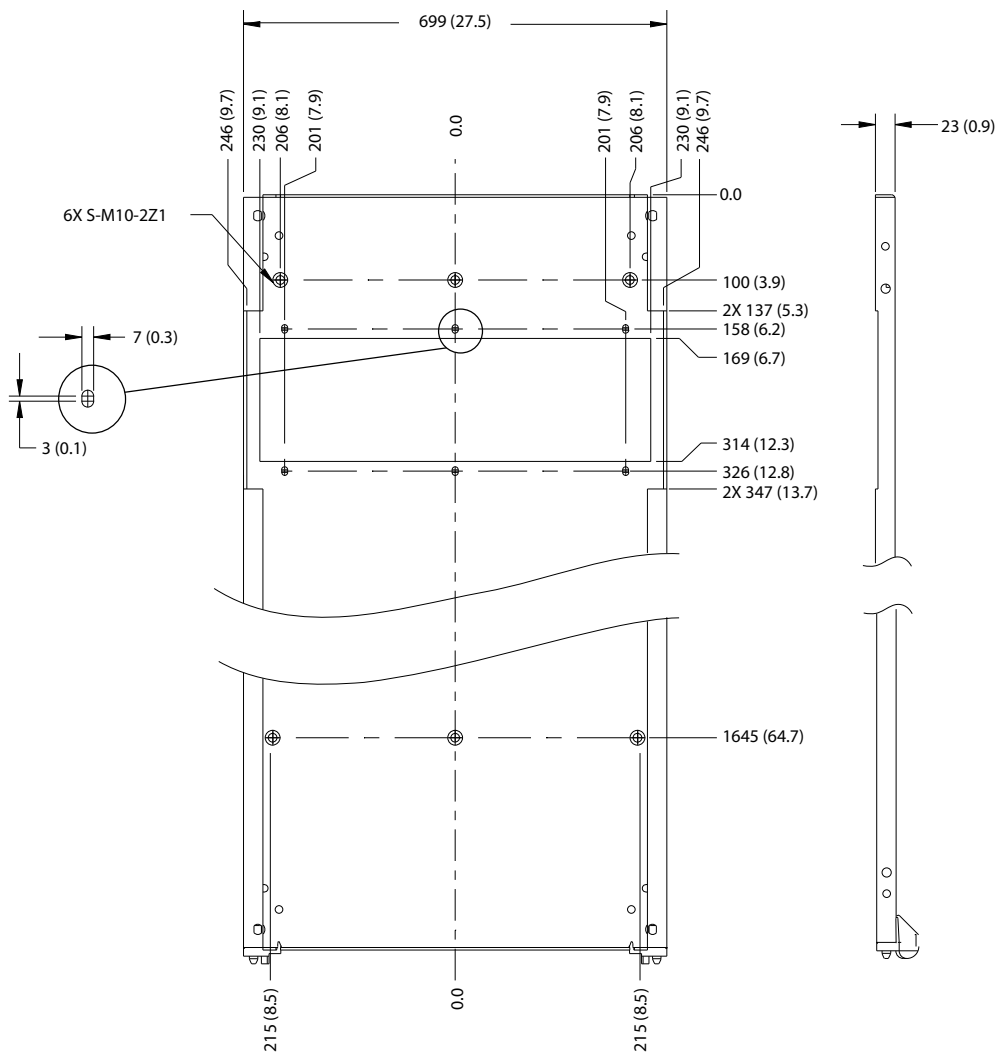

e30bg108.10

Illustration 4: Vent Dimensions for FA11 Mounting Plate in 800 mm (32 in) Cabinet

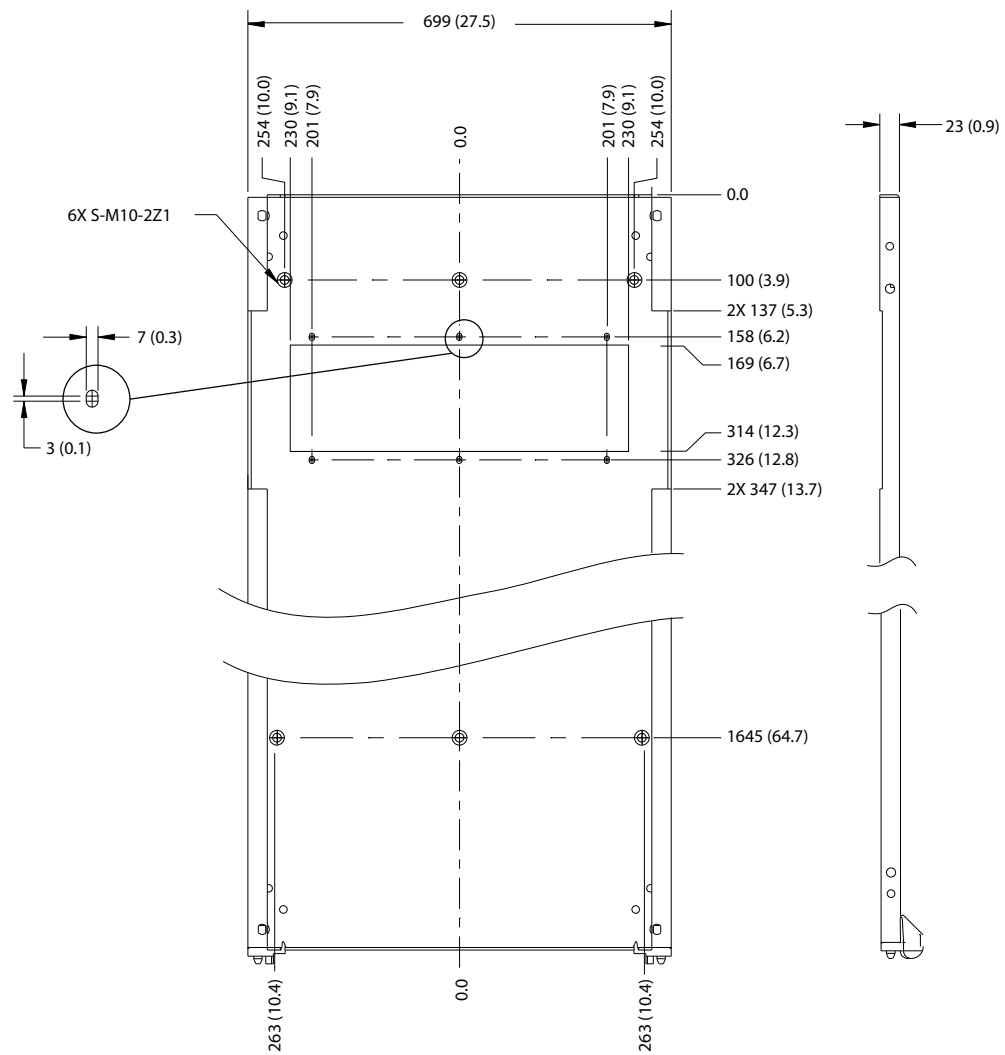

e30bg265.10

Illustration 5: Vent Dimensions for FA12 Mounting Plate in 800 mm (32 in) Cabinet

2.4 Creating Vent Opening in the Backplate

To create a vent opening in the cabinet backplate, use the following steps. Use the dimensions in [Illustration 6](#) for 600 mm (24 in) cabinets, and [Illustration 7](#) for 800 mm (32 in) cabinets.

Procedure

1. Cut out the vent opening in the cabinet backplate using the template dimensions.

The opening must match the frequency converter vent opening.

2. Drill 8 screw holes (6 mm) around the vent opening using the template dimensions.

The holes must match the holes in the outer flange of the back duct.

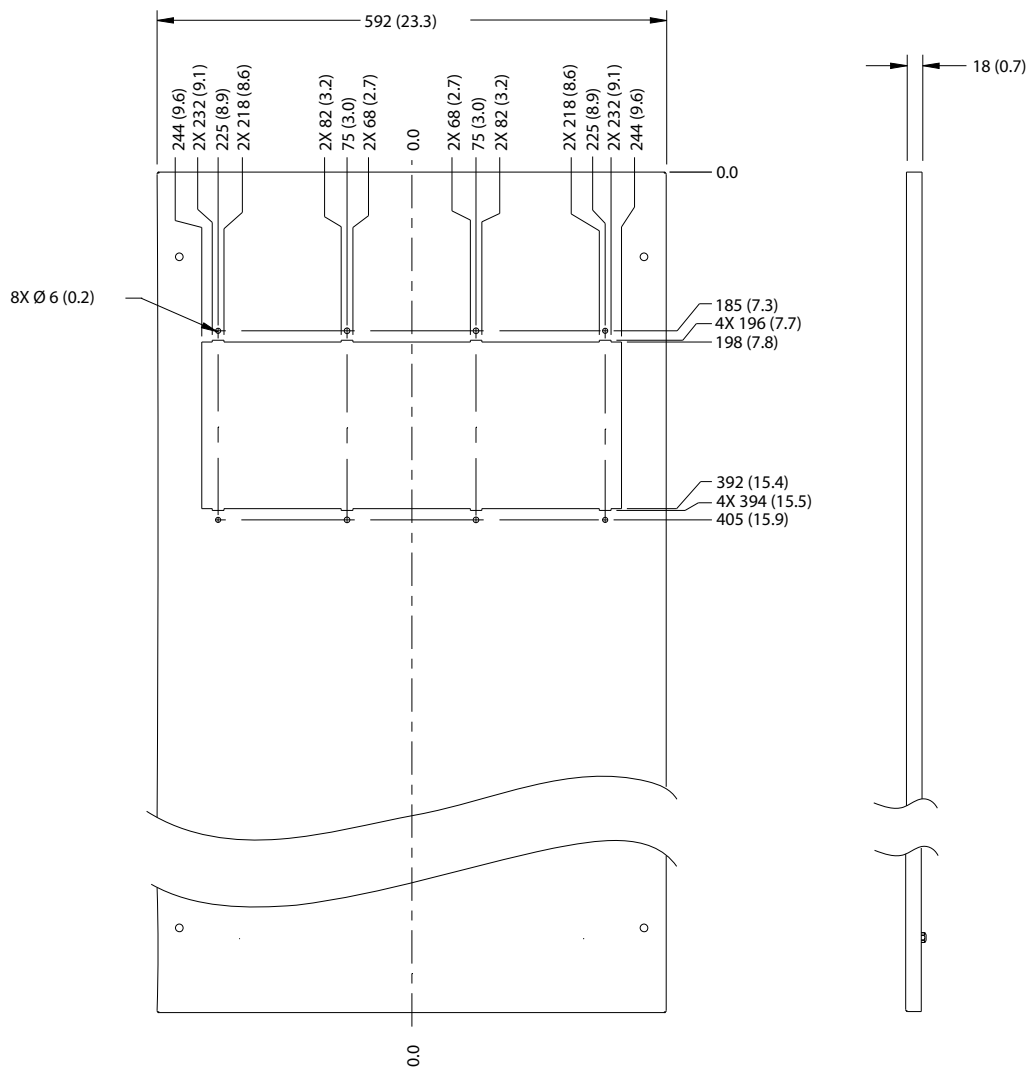

e30bg109.10

Illustration 6: Vent Template for Backplate in 600 mm (24 in) Cabinet

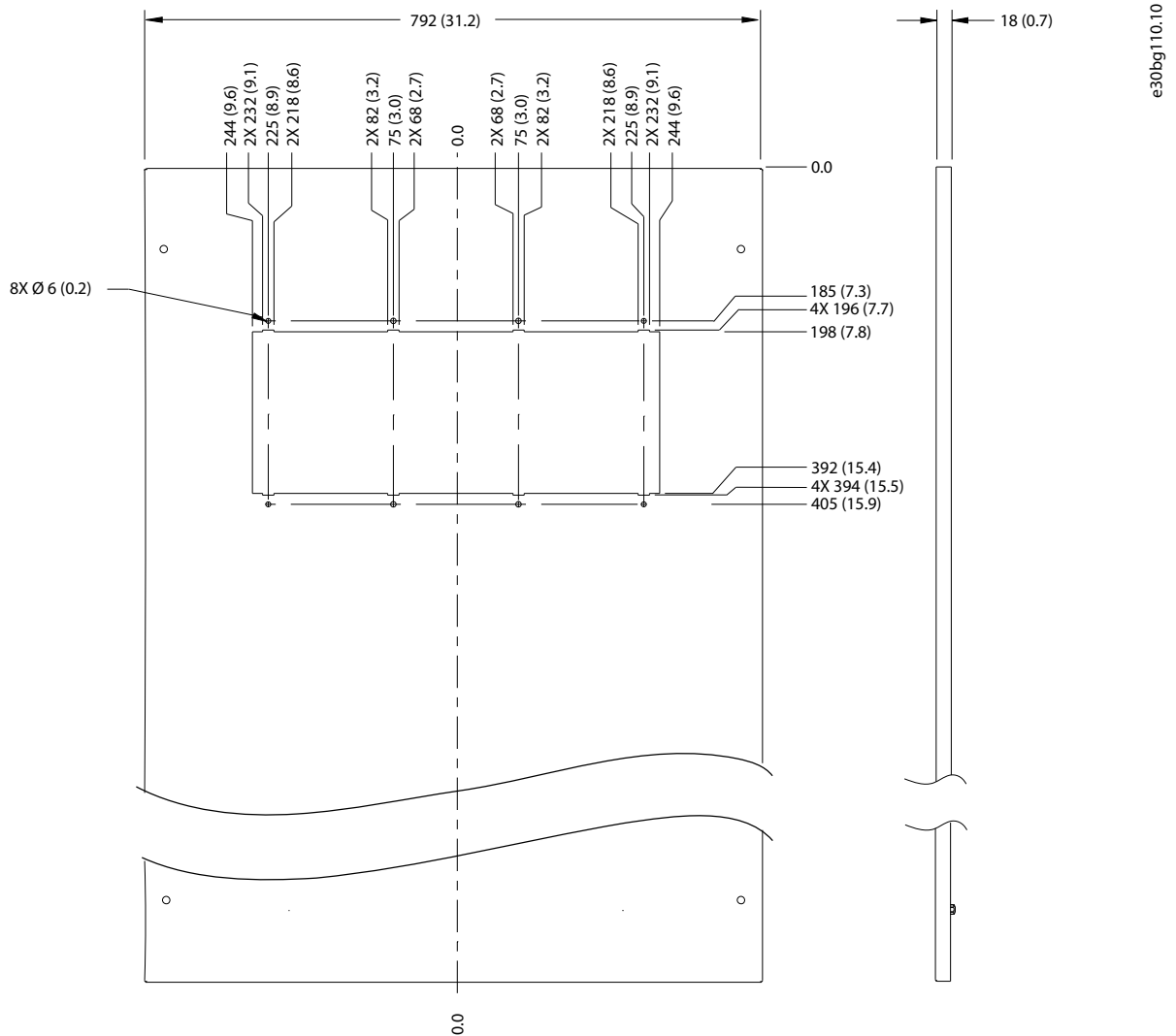

Illustration 7: Vent Template for Backplate in 800 mm (32 in) Cabinet

2.5 Installing the Top Cover

To install the top cover, use the following steps. See [Illustration 8](#).

Procedure

1. Remove paper backing from the top gasket to expose the adhesive.
2. Adhere the top gasket to the underside of the top cover.
3. Remove the M5x14 screws (T25) surrounding the sides and back of the vent in the top of the frequency converter.

Retain the screws. Fx11 converters have 6 screws; Fx12 converters have 7 screws.

4. Loosen 3 M5x12 screws (T25) at the front of the vent in the top surface of the frequency converter.
5. Slide the edge of the top cover plate under the 3 loosened screws, positioning the plate over the vent in the top of the frequency converter.
6. Secure the top cover plate with the M5x14 screws (T25) removed previously in step 3.

Torque all screws to 2.3 Nm (20 in-lb).

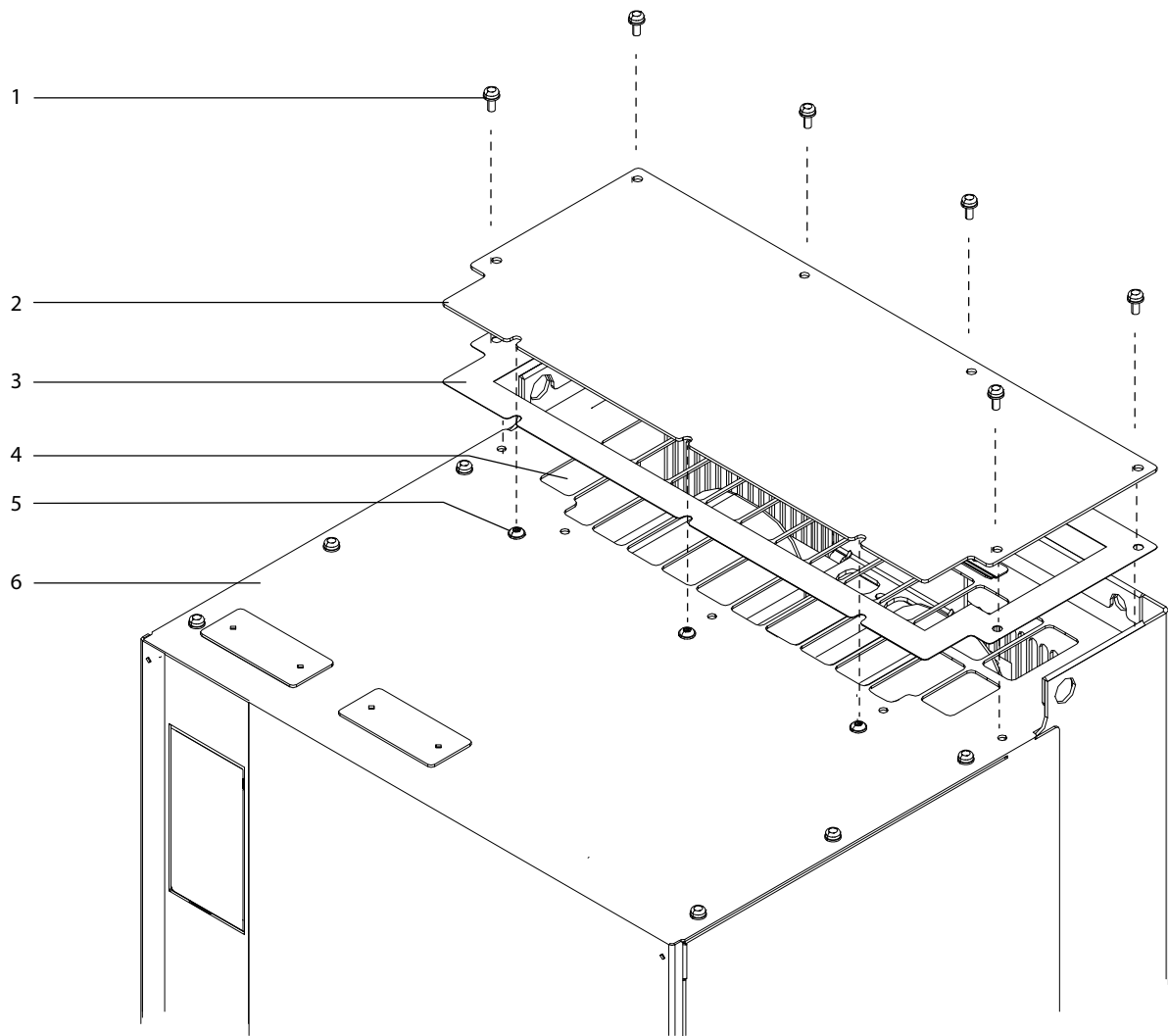

Illustration 8: Installation of Top Cover

1	M5x14 screw	4	Top vent
2	Top cover	5	M5x12 screw (loosened, not removed)
3	Top gasket	6	Top of frequency converter

2.6 Assembling the Bottom Duct

The bottom duct is a telescopic duct that collapses to simplify installation. To assemble the duct before installation, use the following steps. Refer to [Illustration 9](#).

Procedure

1. Cut the strip of ribbed EPDM rubber seal into 2 pieces of 990 mm (39.0 in).
2. Peel the paper off the self-adhesive seals. Place 1 strip on the outside bottom edge of the inner sleeve of the duct, and 1 strip on the upper inside edge of the outer sleeve of the duct.

3. With the rubber seal in place, carefully slide the inner sleeve of the duct into the outer sleeve.

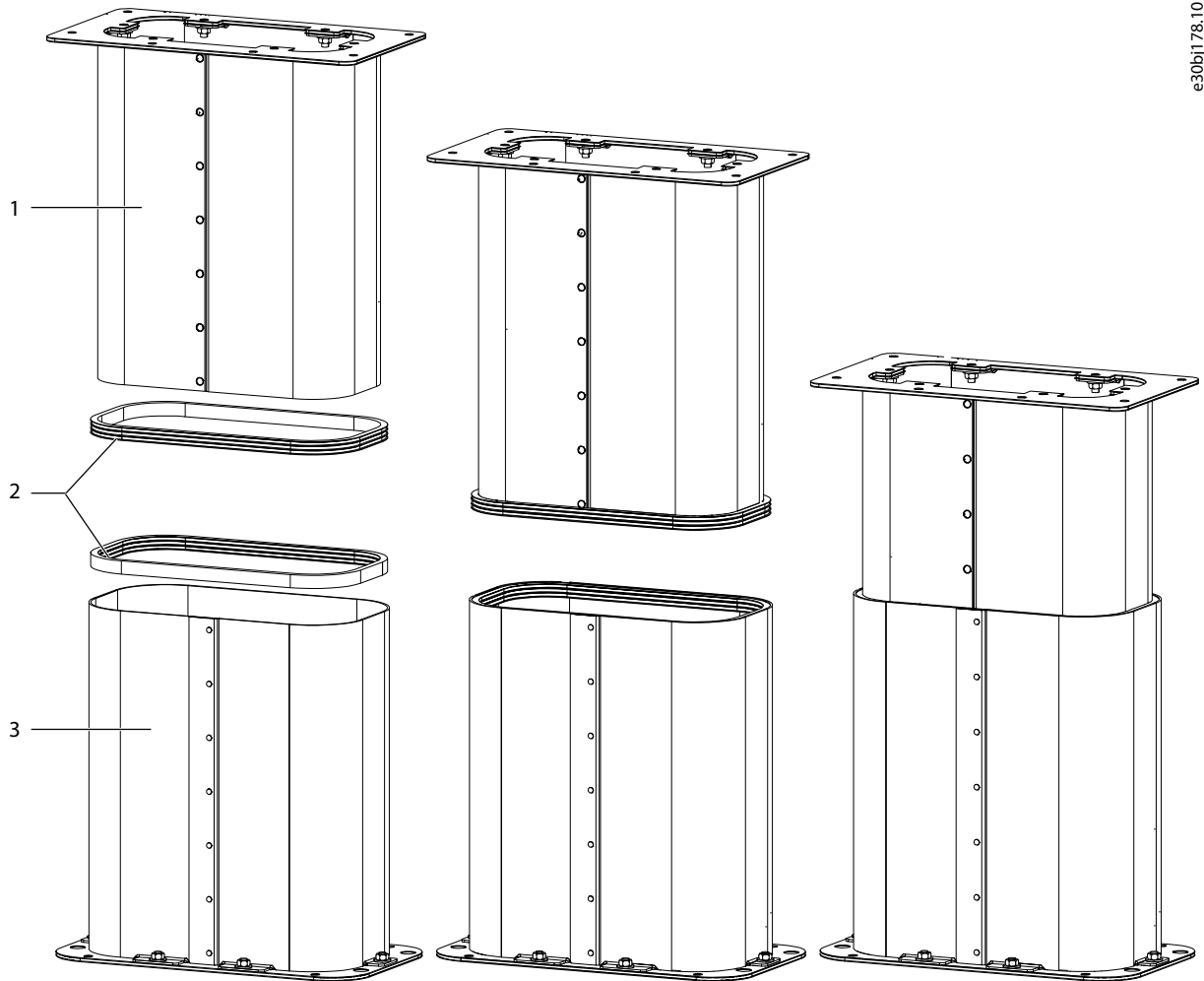

e30bj178.10

Illustration 9: Assembly of Telescopic Duct

1	Inner sleeve of duct	3	Outer sleeve of duct
2	Ribbed EPDM rubber seal		

2.7 Installing the Duct Support Bracket

The duct support bracket attaches the bottom duct to the lower end of the cooling back channel. To install the bracket, use the following steps. Refer to [Illustration 10](#).

Procedure

1. Remove the paper backing from the duct support gasket.
2. Adhere the gasket to the upper surface of the duct support bracket.
3. Position the bracket at the lower end of the cooling back channel.
4. Secure the bracket to the back channel of the frequency converter using 8 M5x14 screws (T25) from the kit.

Torque fasteners to 2.3 Nm (20 in-lb).

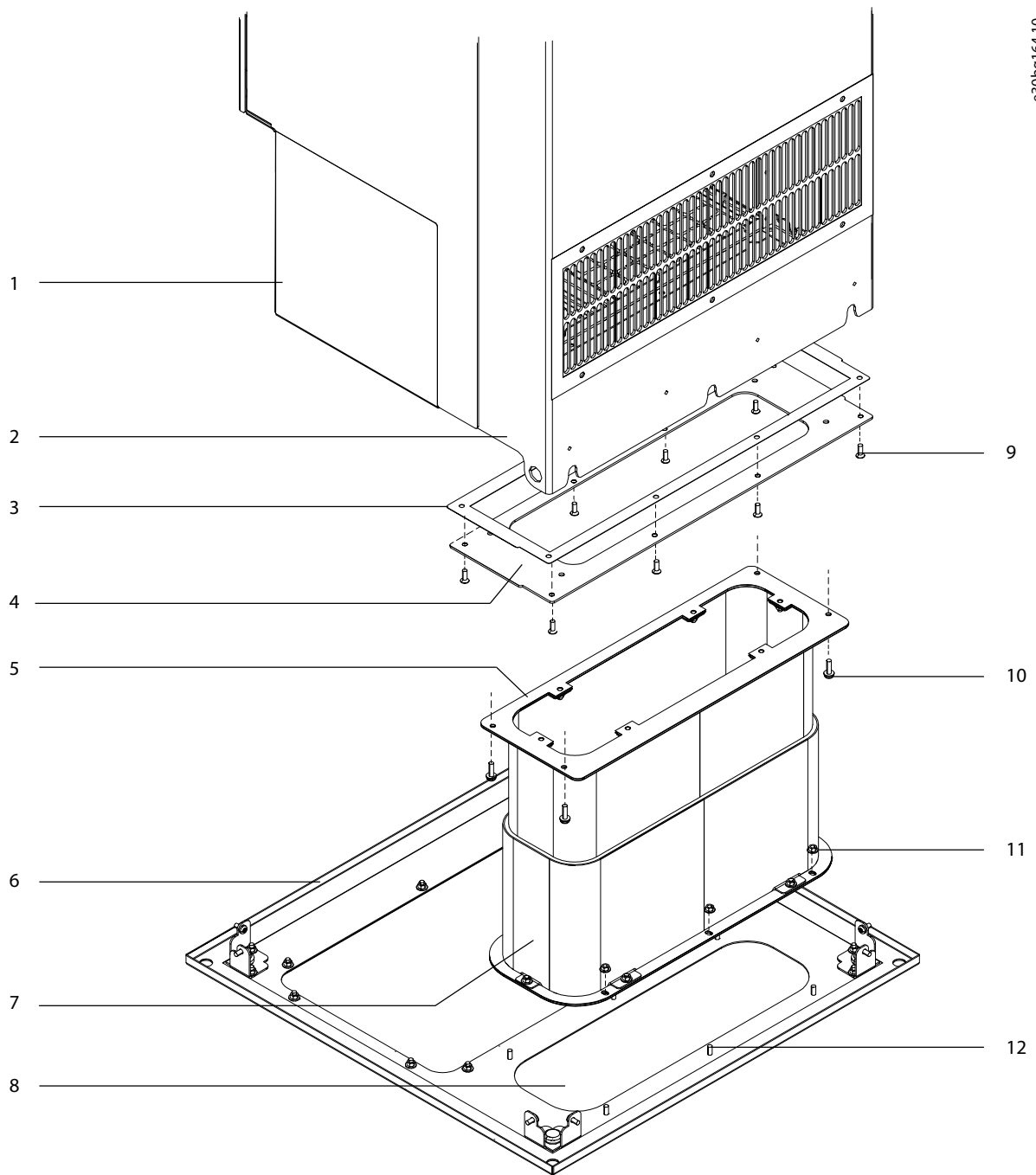

Illustration 10: Installation of the Duct Support Bracket

1	Frequency converter	7	Bottom duct assembly
2	Back channel	8	Opening for duct
3	Duct support gasket	9	M5x14 screw
4	Duct support bracket	10	M5x18 screw
5	Upper flange of duct	11	M5 hex nut
6	Cabinet base plate	12	Threaded stud

2.8 Installing the Base Plate and Bottom Duct

To attach the bottom duct to the base plate of the cabinet, use the following steps. Refer to [Illustration 11](#).

Procedure

1. Remove the base plate from the Rittal cabinet and replace it with the base plate from the kit, which has a vent opening for the bottom duct.
2. Position the bottom duct over the vent opening in the base plate.
3. Place the holes in the lower flange of the duct over the 6 threaded studs surrounding the opening in the base plate.
4. Fasten 6 M5 hex nuts (T25) to the threaded studs.
5. Collapse the duct and install the base plate between the pedestal and the cabinet frame using the existing fasteners.

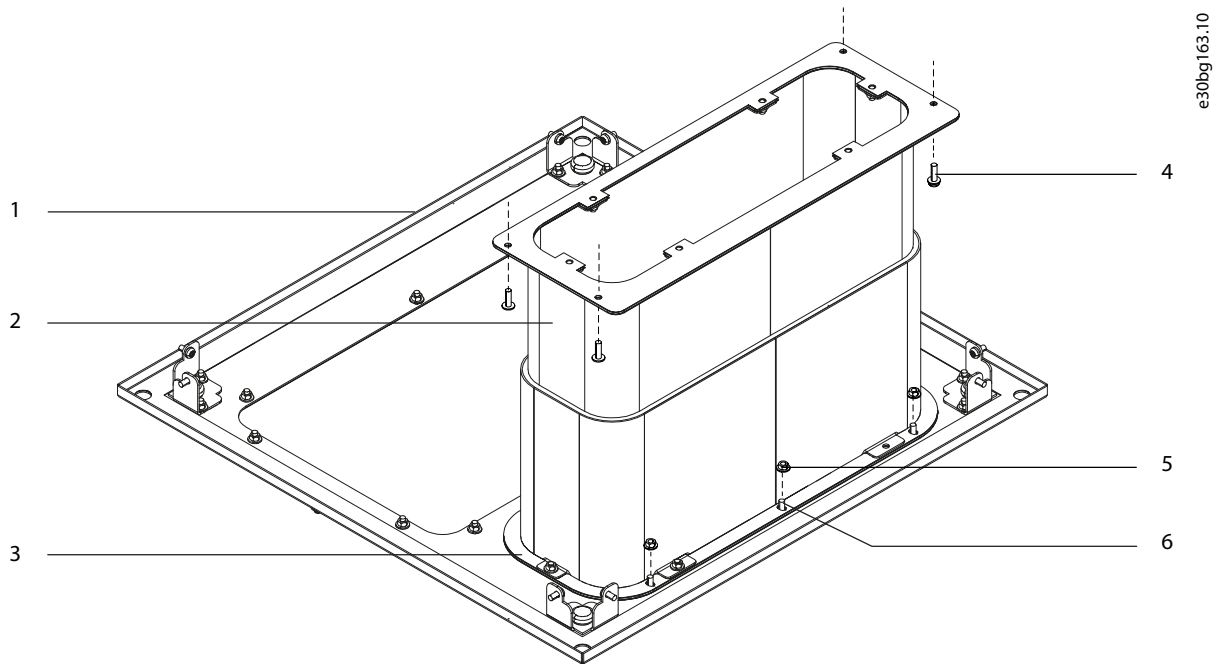

Illustration 11: Installation of the Bottom Duct on the Base Plate

1	Base plate (with opening for duct)	4	M5x18 screw
2	Bottom duct assembly	5	M5 hex nut
3	Lower flange of duct	6	Threaded stud

2.9 Mounting the Frequency Converter

To install the mounting plate and frequency converter in the cabinet, use the following steps. Refer to [Illustration 12](#).

Procedure

1. Remove the paper backing from both 6-hole gaskets, exposing the adhesive.
2. Adhere 1 gasket around the vent opening on each side of the mounting plate.
3. Position the mounting plate in the Rittal cabinet, aligning the top mounting plate hole with the 5th hole from the top of the cabinet rails.

Check that the pem nuts face the back of the cabinet.

4. Fasten the mounting plate to the cabinet rails with 14 M5x10 thread-forming screws.
5. Loosely fasten 3 M10 screws (not supplied) into the pem nuts at the lower end of the mounting plate.

Check that the screws are secure. The base of the frequency converter rests on the screws.

6. Slightly lean the top of the frequency converter forward and set the cutouts in the base onto the 3 screws.
7. Slowly push the top of the frequency converter back against the mounting plate until the top 3 pem nuts line up with the holes in the frequency converter.

- Secure the top of the frequency converter using 3 M10 screws.

Torque the 6 M10 screws to 19 Nm (170 in-lb).

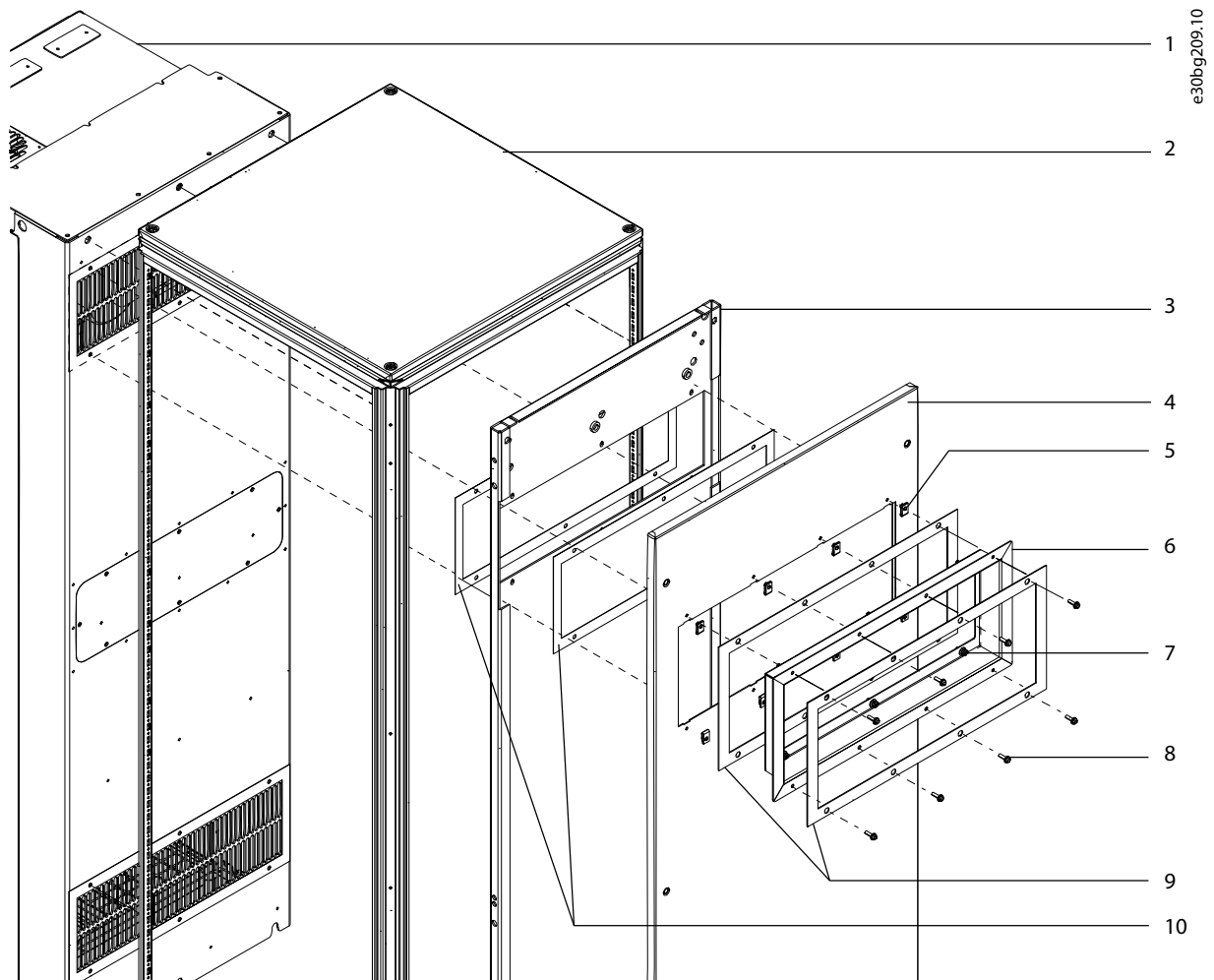

Illustration 12: Installation in Cabinet

1	Frequency converter	6	Back duct
2	Rittal cabinet	7	M6x12 screw
3	Mounting plate	8	M5x18 screw
4	Backplate	9	8-hole gaskets
5	M5 clip-on nut	10	6-hole gaskets

2.10 Attaching the Bottom Duct to the Duct Support Bracket

After the frequency converter is installed on the mounting plate, attach the telescopic bottom duct to the duct support bracket using the following steps.

Procedure

- Extend the telescopic bottom duct upward until the upper flange of the duct is positioned against the duct support bracket.
- Secure the duct to the bracket with 4 M5x14 screws (T25).

Torque fasteners to 2.3 Nm (20 in-lb).

2.11 Installing the Backplate and Back Duct

To attach the cabinet backplate and the back duct, use the following steps.

Procedure

1. Position the backplate on the back rails of the cabinet behind the mounting plate.
2. Secure the backplate to the rails using the existing fasteners.
3. Slide 8 M5 clip-on nuts over the screw holes around the duct opening in the backplate.
4. Remove the paper backing from both 8-hole gaskets, exposing the adhesive.
5. Adhere 1 gasket to the back and 1 gasket to the front of the back duct outer flange.
6. Position the back duct in the hole created for it in the mounting plate and backplate.
7. Fasten the inner flange of the back duct with 6 M6x12 screws (T30).

Torque to 3.9 Nm (35 in-lb).

8. Fasten the outer flange of the duct with 8 M5x18 screws (T25).

Torque fasteners to 2.3 Nm (20 in-lb).

Danfoss A/S
Ulsnaes 1
DK-6300 Graasten
drives.danfoss.com

Any information, including, but not limited to information on selection of product, its application or use, product design, weight, dimensions, capacity or any other technical data in product manuals, catalogues descriptions, advertisements, etc. and whether made available in writing, orally, electronically, online or via download, shall be considered informative, and is only binding if and to the extent, explicit reference is made in a quotation or order confirmation. Danfoss cannot accept any responsibility for possible errors in catalogues, brochures, videos and other material. Danfoss reserves the right to alter its products without notice. This also applies to products ordered but not delivered provided that such alterations can be made without changes to form, fit or function of the product. All trademarks in this material are property of Danfoss A/S or Danfoss group companies. Danfoss and the Danfoss logo are trademarks of Danfoss A/S. All rights reserved.

