

Installation Instructions

LOP Connection and Set-up

VLT[®] DriveMotor FCP/FCM 106

Items Supplied

- Local operating panel (LOP), 175N0128 IP65, see *Illustration 1.1*.
- Fixture for LOP, 175N2717 (included in 175N0128), see *Illustration 1.2*.
- LOP cable.

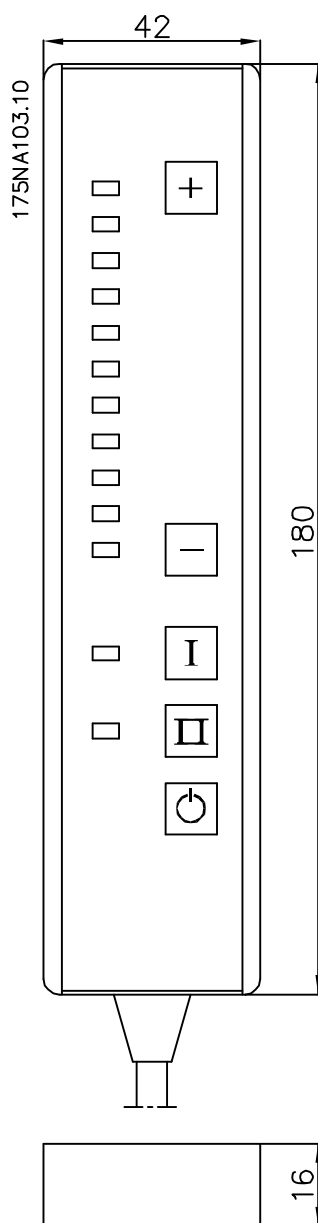

Illustration 1.1 Local Operation Panel (LOP) 175N0128 IP65

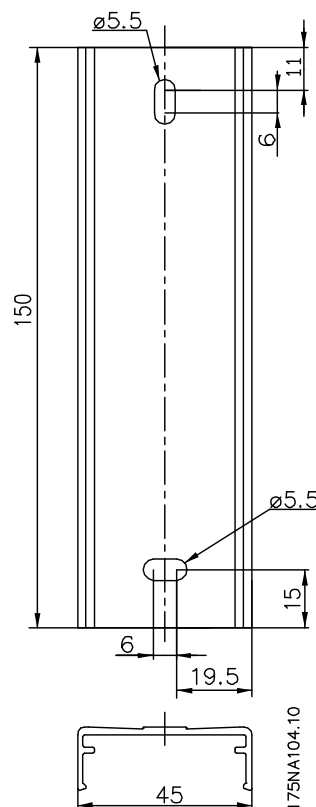

Illustration 1.2 Fixture for LOP 175N2717 (included in 175N0128)

Safety Instructions

Refer to *VLT® DriveMotor FCP 106 and FCM 106 Operating Guide* for detailed information about safety precautions for installation.

⚠ WARNING

DISCHARGE TIME

The frequency converter contains DC-link capacitors, which can remain charged even when the frequency converter is not powered. High voltage can be present even when the warning LED indicator lights are off. Failure to wait the specified time after power has been removed before performing service or repair work can result in death or serious injury.

1. Stop the motor.
2. Disconnect AC mains, permanent magnet type motors, and remote DC-link supplies, including battery back-ups, UPS, and DC-link connections to other frequency converters.
3. Wait for the capacitors to discharge fully, before performing any service or repair work. The waiting time is specified in *Table 1.1*.

Voltage [V]	Power range ¹⁾ [kW (hp)]	Minimum waiting time (minutes)
3x400	0.55–7.5 (0.75–10)	4

Table 1.1 Discharge Time

¹⁾ Power ratings relate to NO, see *VLT® DriveMotor FCP 106 and FCM 106 Operating Guide*.

Connection to FCP 106 or FCM 106

1. Connect the LOP as shown in *Table 1.2* and *Illustration 1.3*.
2. After completing connections, cut off or isolate excess wire.
3. Connect terminal 27 to +24 V or set *parameter 5-12 Terminal 27 Digital Input* to [0] No operation or [1] Reset, see footnote 2 in *Table 1.3*.

Terminal	Dual-speed operation	Dual-mode operation	Dual-direction operation
18	Purple or orange		Gray
27	Brown		
29	Green		
12	Red		
50	Yellow		
53	White		
55	Blue		

Table 1.2 Electrical Connections

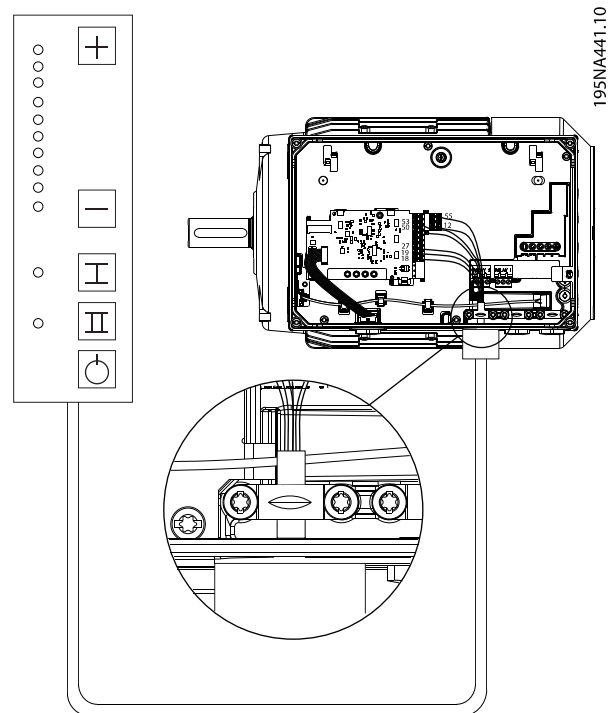

Illustration 1.3 LOP Connections to FCP 106 or FCM 106

Set-up

1. Perform set-up according to *Table 1.3*.
2. Use the [+]/[-] keys to set reference.
3. At power-up, the unit is always in stop mode. The set reference is stored during power down. To set up permanent start mode, connect terminal 12 to terminal 18 and do not connect purple/orange/gray wire to terminal 18. Permanent start mode disables the stop function on the LOP.

Function	Settings	Key I (Start)	Key II (Start)	 Key (Stop)
Default - Dual speed operation (connect purple or orange wire)	No changes to factory setting.	Run on set reference (+/-)	Run on 5 Hz ¹⁾ jog speed	Stop (and reset ²⁾ - if trip)
Function 2 - Dual-mode operation (connect purple or orange wire)	Select the modes of operation in set-ups 1 and 2. Set <i>parameter 0-10 Active Set-up</i> to [9] <i>Multi Set-up</i> . Set <i>parameter 5-13 Terminal 29 Digital Input</i> to [23] <i>Set-up select bit 0</i> .	Run with set-up 1	Run with set-up 2	Stop (and reset ²⁾ - if trip)
Function 3 - Dual direction operation (connect gray wire)	Set <i>parameter 4-10 Motor Speed Direction</i> to [2] <i>Both directions</i> . Set <i>parameter 5-13 Terminal 29 Digital Input</i> to [11] <i>Start reversing</i> .	Run forward	Run reverse	Stop (and reset ²⁾ - if trip)

Table 1.3 LOP Operating Mode

1) Set jog speed in parameter 3-11 Jog Speed [Hz].

2) When reset is required, set parameter 5-12 Terminal 27 Digital Input to [1] Reset.

.....
Danfoss can accept no responsibility for possible errors in catalogues, brochures and other printed material. Danfoss reserves the right to alter its products without notice. This also applies to products already on order provided that such alterations can be made without subsequential changes being necessary in specifications already agreed. All trademarks in this material are property of the respective companies. Danfoss and the Danfoss logotype are trademarks of Danfoss A/S. All rights reserved.
.....

Danfoss A/S
Ulsnaes 1
DK-6300 Graasten
vlt-drives.danfoss.com

