

Installation Instructions

Motor Adapter Plate

1.1.1 Items Supplied

- Motor adapter plate
- Accessory bag
 - motor plug
 - motor connector gasket
 - screws

1.1.2 Additional Items Required

- FCP 106 frequency converter
- Motor
- Customised gasket to fit between motor and motor adapter plate. For information refer to *Prepare Gasket* in *VLT® DriveMotor FCP 106 and FCM 106 Operating Instructions*.
- Crimp terminals. Order numbers from manufacturer TE (AMP standard power timer contacts):
 - 927827-1 (0.5-1 mm²) [AWG 20-17]
 - 927833-1 (1.5-2.5 mm²) [AWG 15.5-13.5]
 - 927824-1 (2.5-4 mm²) [AWG 13-11]

1.1.3 Safety Instructions

For important information about safety precautions for installation, refer to *VLT® DriveMotor FCP 106 and FCM 106 Operating Instructions*

⚠ WARNING

DISCHARGE TIME

The frequency converter contains DC-link capacitors, which can remain charged even when the frequency converter is not powered. Failure to wait the specified time after power has been removed before performing service or repair work, could result in death or serious injury.

1. Stop motor.
2. Disconnect AC mains, permanent magnet type motors, and remote DC-link power supplies, including battery back-ups, UPS, and DC-link connections to other frequency converters.
3. Wait for the capacitors to discharge fully, before performing any service or repair work. The duration of waiting time is specified in *Table 1.1*.

| Voltage [V] | Power Range ¹⁾ [kW] | Minimum waiting time (min) |
|---|--------------------------------|----------------------------|
| 3x400 | 0.55–7.5 | 4 |
| High voltage can be present even when the warning LED indicator lights are off. | | |

Table 1.1 Discharge Time

¹⁾ Power ratings relate to NO, see *VLT® DriveMotor FCP 106 and FCM 106 Operating Instructions*.

1.1.4 Prepare Adapter Plate

The adapter plate is available with or without pre-drilled holes.

For adapter plate with no pre-drilled holes, refer to *Illustration 1.1*.

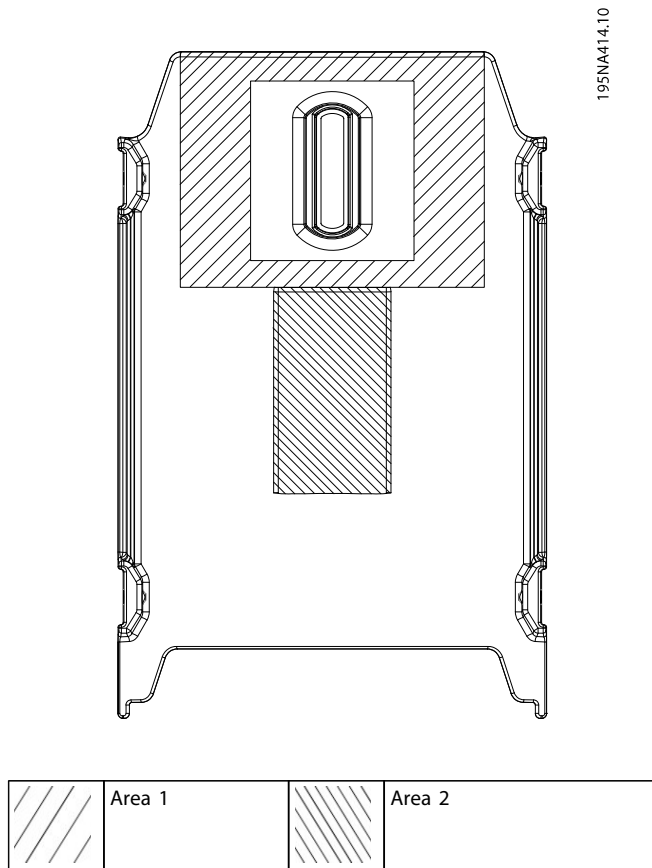

Illustration 1.1 Adapter Plate, Guide for Drilling Holes

When the adapter plate has no holes, drill them as follows:

- 4 holes within area 1, for fastening adapter plate to motor (required).
- 1 hole within area 2, for a lifting lug (optional).
- Make allowance for countersunk screws.

For adapter plate with pre-drilled holes, no extra holes are required. Pre-drilled holes are specific for FCM 106 motors only.

1.1.5 Connect FCP 106 to Motor

NOTICE

To avoid damage to equipment, before mounting the FCP 106 on the motor, observe

- cooling clearances
- screw clearances

Clearances are specified in *VLT® DriveMotor FCP 106 and FCM 106 Operating Instructions*

NOTICE

RISK OF DAMAGE

Risk of damage to motor or frequency converter exists if screws extend too far into the enclosure or too far above the adapter plate.

To connect the FCP 106 to the motor, follow the installation steps shown in *Table 1.2* and *Illustration 1.2*.

| Step | Description |
|------|---|
| 1 | Mount motor phases and thermistor wires in crimp terminals. |
| 2 | Mount PE clamp to motor connector and connect crimp PE terminal to wire. |
| 3 | Mount the customised gasket between the motor and adapter plate. <i>See Additional Items Required.</i> |
| 4 | Pull motor phases and thermistor wires through the neck of the adapter plate. |
| 5 | Mount the adapter plate onto the motor using 4 screws. <ul style="list-style-type: none"> • Select screw type and tightening torque to suit the motor. • Insert guide pins into 2 of the screw holes, before lowering the adapter plate into position. Remove the guide pins when mounting screws. • Ensure metallic contact is established between the adapter plate and the motor, via the screws. |
| 6 | Mount motor connector gaskets onto the neck of the adapter plate. |
| 7 | Click the terminals into the motor connector. <ul style="list-style-type: none"> • Mount the 3 motor phases. • Mount the 2 thermistor wires. • Mount PE connector • For correct installation refer to terminal numbers printed on the motor connector. <p>NOTICE</p> <p>The thermistor is not galvanically isolated. Interchanging the thermistor wires with the motor wires may permanently damage the frequency converter.</p> |
| 8 | Click motor connector into the neck of the adapter plate. |
| 9 | Position FCP 106 on adapter plate. |
| 10 | Fasten the FCP 106 to adapter plate using 4 screws, supplied. Screwdriver Torx 20, tightening torque 7.0 Nm |

Table 1.2 Installation Steps as Shown in *Illustration 1.2*

The FCP 106 is now mounted onto the motor. The combined unit is known as the DriveMotor.

For motor shaft alignment, see *VLT® DriveMotor FCP 106 and FCM 106 Operating Instructions*.

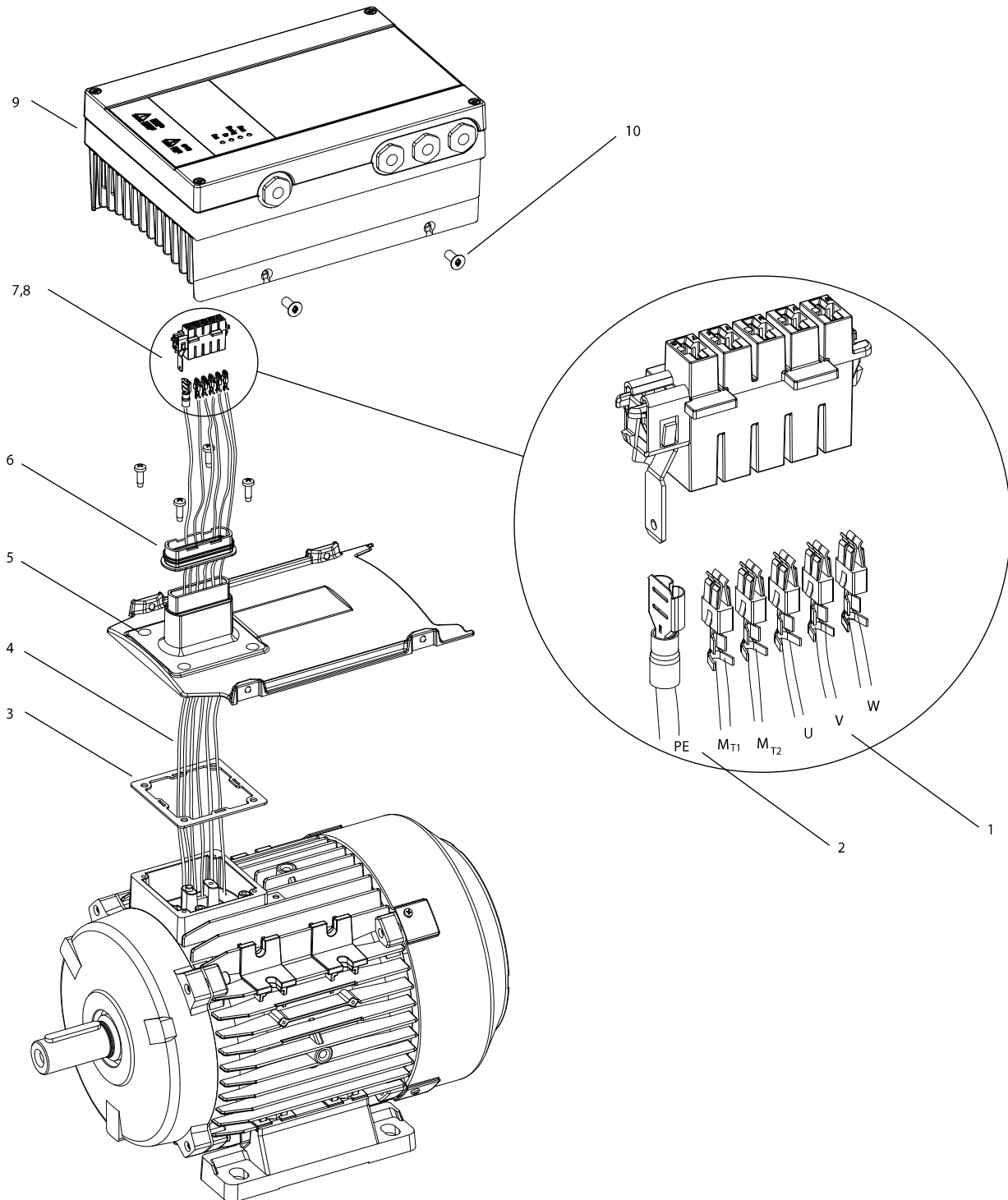

| | |
|-----------------------------------|------------------------|
| M _{T1} , M _{T2} | Motor thermistor wires |
| U, V, W | Motor phases |

Illustration 1.2 Connecting FCP 106 to Motor

Danfoss can accept no responsibility for possible errors in catalogues, brochures and other printed material. Danfoss reserves the right to alter its products without notice. This also applies to products already on order provided that such alterations can be made without consequential changes being necessary in specifications already agreed. All trademarks in this material are property of the respective companies. Danfoss and the Danfoss logotype are trademarks of Danfoss A/S. All rights reserved.

