

# Installation Instructions

## Current Sensor Cylinder Busbar Kit (D1h–D8h)

### VLT<sup>®</sup> FC Series FC 102, FC 103, FC 202, FC 302

#### Description

The current sensor cylinder busbar kits include all parts required to install the cylinder busbars in D1h–D8h drives. Each cylinder busbar is inserted through the center of a current sensor during installation. For more information, see the current sensor kit installation instructions listed in *Table 1.4*.

#### Kit Ordering Numbers

Kit number	Kit description
176F6517	300 A D1 LEM BB kit
176F6757	300 A D2 LEM BB kit
176F6756	500 A D2 LEM BB kit

Table 1.1 Ordering Numbers for Current Sensor Cylinder Busbar Kits

#### Items Supplied

Item	Quantity
Nomex sleeve	3
U, V, W cylinder busbars	1 set of 3
M6x90 screw	3
Cylinder busbar mounting frame	1
M6x16 screw	3

Table 1.2 Items Supplied with D1h/D3h/D5h/D6h Kit (176F6517)

Item	Quantity
Nomex sleeve	3
U, V, W cylinder busbars	1 set of 3
M8x70 screw	3

Table 1.3 Items Supplied with D2h/D4h/D7h/D8h Kit (176F6756/176F6757)

#### Safety Information

Only qualified, Danfoss authorized personnel are allowed to install the parts described in these installation instructions. Handling of the drive and its parts must be done in accordance with the corresponding *operating guide*.

#### **⚠ WARNING**

##### ELECTRICAL SHOCK HAZARD

VLT<sup>®</sup> FC series drives contain dangerous voltages when connected to mains voltage. Improper installation, and installing or servicing with power connected, can cause death, serious injury, or equipment failure.

To avoid death, serious injury, or equipment failure:

- Only use qualified electricians for the installation.
- Disconnect the drive from all power sources before installation or service.
- Treat the drive as live whenever the mains voltage is connected.
- Follow the guidelines in these instructions and local electrical safety codes.

#### **⚠ WARNING**

##### DISCHARGE TIME

The drive contains DC-link capacitors, which can remain charged even when the drive is not powered. High voltage can be present even when the warning LED indicator lights are off. Failure to wait the specified time after power has been removed before performing service or repair work can result in death or serious injury.

- Stop the motor.
- Disconnect AC mains and remote DC-link power supplies, including battery back-ups, UPS, and DC-link connections to other drives.
- Disconnect or lock PM motor.
- Wait for the capacitors to discharge fully. The minimum waiting time is 20 minutes.
- Before performing any service or repair work, use an appropriate voltage measuring device to make sure that the capacitors are fully discharged.

### Cylinder Busbar Identification

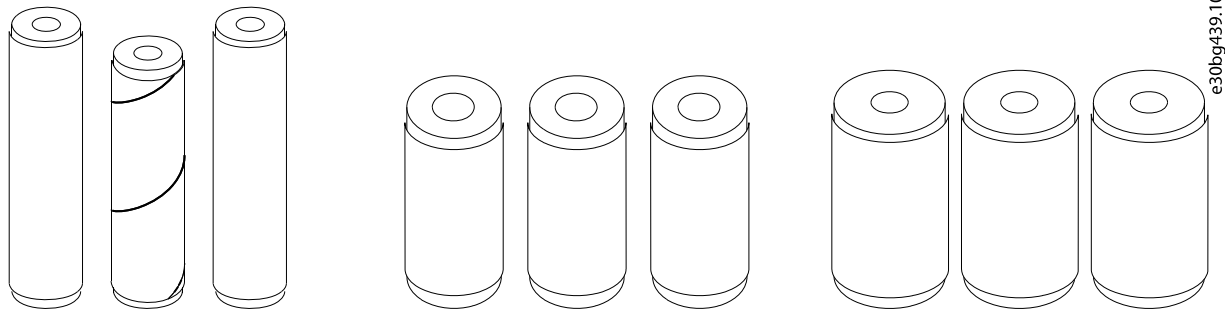

e30bg439:10

Kit 176F6517	Kit 176F6757	Kit 176F6756
90/110/132 kW power rating	160 kW power rating	200/250 kW power rating
V-phase busbar: 64 mm x Ø16 mm U/W-phase busbar: 71 mm x Ø16 mm	U/V/W-phase busbar: 49 mm x Ø19 mm	U/V/W-phase busbar: 49 mm x Ø25 mm

Illustration 1.1 Current Sensor Cylinder Busbars

Busbar kit	Current sensor kit	Kit description	Installation instruction
176F6517	176F6516	300 A D1 retro fit kit	300 A Current Sensor Kit for D1h/D3h/D5h/D6h Drives
176F6757	176F3752	300 A D2 retro fit kit	300 A/500 A Current Sensor Kit for D2h/D4h/D7h/D8h Drives
176F6756	176F3737	500 A D2 retro fit kit	300 A/500 A Current Sensor Kit for D2h/D4h/D7h/D8h Drives

Table 1.4 Comparison of Current Sensor Cylinder Busbar Kits

### Assembling the Current Sensor Cylinder Busbars in D1h/D3h/D5h/D6h Drives

#### **⚠ WARNING**

#### **NOMEX SLEEVES REQUIRED**

The Nomex sleeves are required to maintain proper electrical protection. Failure to install the Nomex sleeves can result in personal injury or equipment damage.

- Do not discard the Nomex sleeves.

Use the following steps to assemble the current sensor cylinder busbars in D1h/D3h/D5h/D6h drives. Refer to *Illustration 1.2*.

1. Place the 3 Nomex sleeves over the cylinder busbars, 1 per busbar. Place the sleeve with the red marking on the short busbar.
2. Insert 3 M6x90 screws through the center of the busbars and place the busbar mounting frame, 1 screw per busbar. The busbar with the red marking is the V busbar and is mounted in the middle.
3. Retain 3 M6x16 screws to fasten the busbar mounting frame in the drive when installing the current sensors. The cylinder busbars are inserted through the centers of the current sensors. Refer to *300 A Current Sensor Kit for D1h/D3h/D5h/D6h Drives* installation instruction.

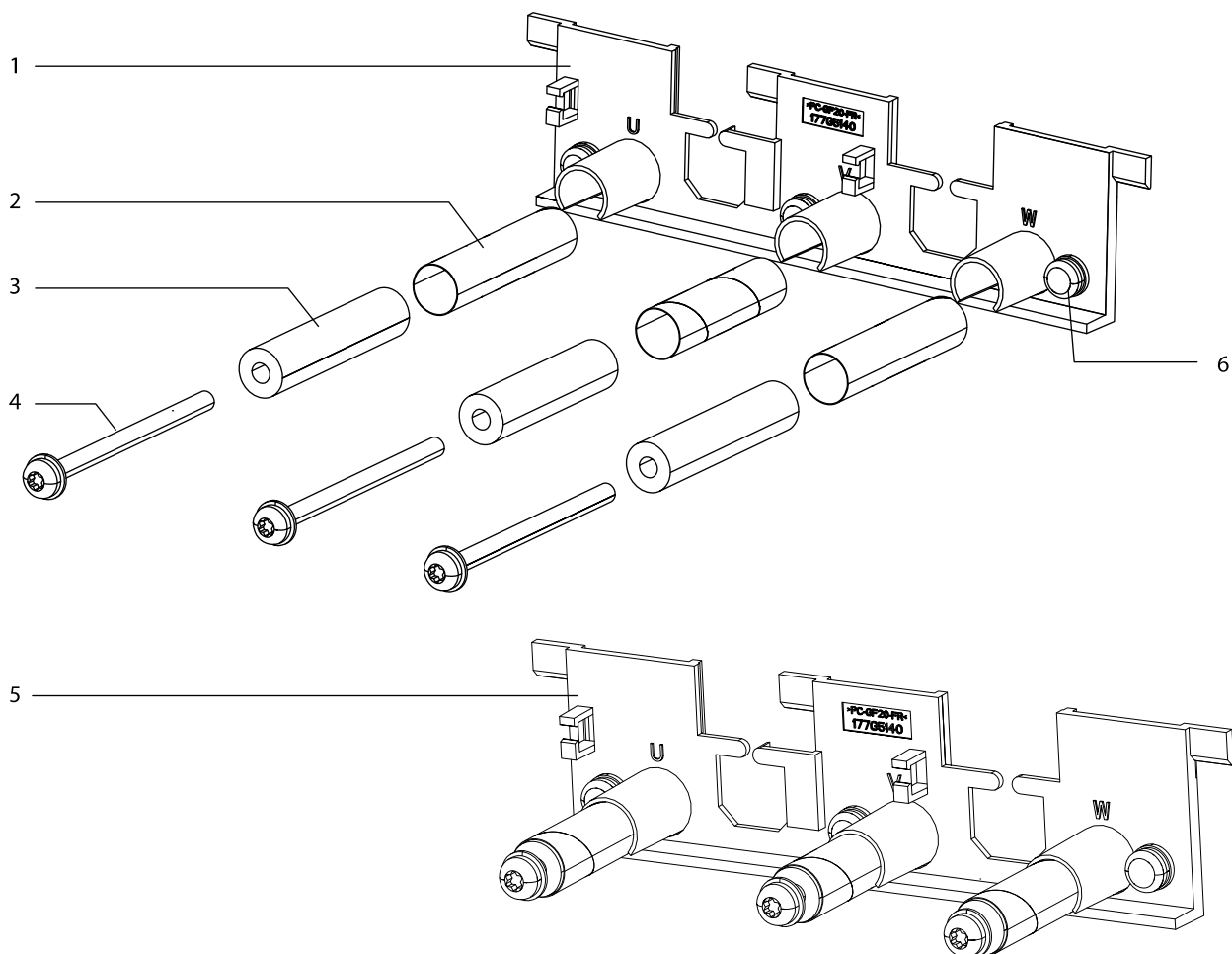

e30bg438.10

1	Cylinder busbar mounting frame	4	M6x90 screw
2	Nomex tube	5	Cylinder busbars (assembled)
3	Cylinder busbar	6	M6x16 screw

Illustration 1.2 Current Sensor Cylinder Busbar Assembly in D1h/D3h/D5h/D6h Drives

## Assembling the Current Sensor Cylinder Busbars in D2h/D4h/D7h/D8h Drives

### **⚠WARNING**

#### **NOMEX SLEEVES REQUIRED**

The Nomex sleeves are required to maintain proper electrical protection. Failure to install the Nomex sleeves can result in personal injury or equipment damage.

- Do not discard the Nomex sleeves.

Use the following steps to assemble the current sensor cylinder busbars in D2h/D4h/D7h/D8h drives.

1. Place the 3 Nomex sleeves over the cylinder busbars, 1 per busbar.
2. Insert 3 M8x70 screws through the center of the busbars, 1 screw per busbar.
3. The cylinder busbars are inserted through the centers of the current sensors when installing the current sensors in the drive. See *300 A/500 A Current Sensor Kit for D2h/D4h/D7h/D8h Drives* installation instruction.

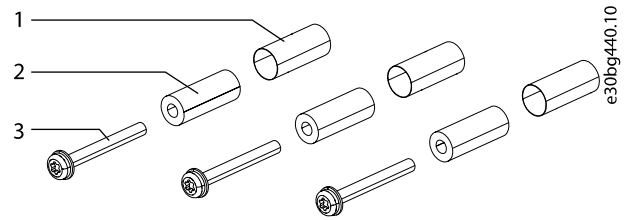

1	Nomex sleeve
2	Cylinder busbar
3	M8x70 screw

**Illustration 1.3 Current Sensor Cylinder Busbar Assembly in D2h/D4h/D7h/D8h Drives**

Danfoss can accept no responsibility for possible errors in catalogues, brochures and other printed material. Danfoss reserves the right to alter its products without notice. This also applies to products already on order provided that such alterations can be made without consequential changes being necessary in specifications already agreed. All trademarks in this material are property of the respective companies. Danfoss and the Danfoss logotype are trademarks of Danfoss A/S. All rights reserved.

