

## MCI 15BP Soft Start Motor Controller

### Montering - Mounting - Montage

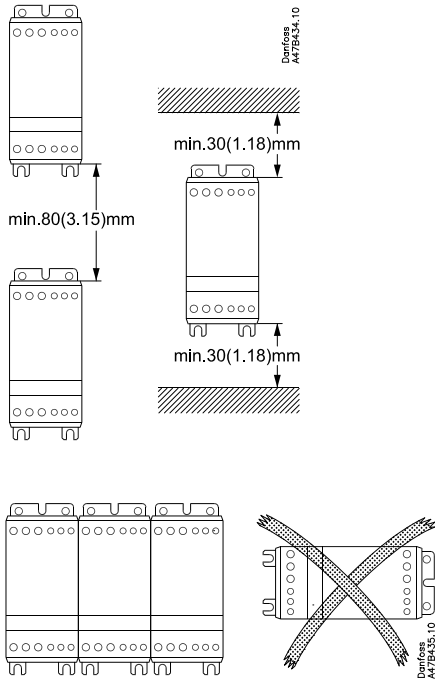

### Mål - Dimensions - Abmessungen

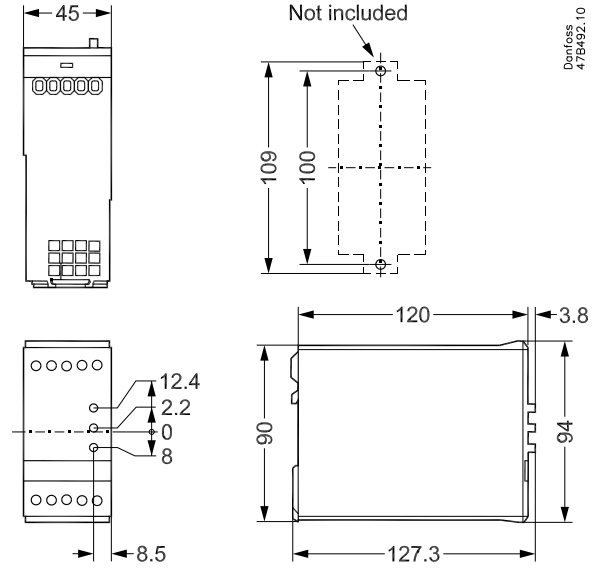

- !** DK Luftstrøm må ikke blokeres  
 UK Airflow should not be blocked  
 D Luftstrom muß ungehindert fließen

### Forbindelse - Wiring - Verdrahtung

75°C		
Kabel/Wire	mm <sup>2</sup> (AWG)	mm <sup>2</sup> (AWG)
	0.75 - 4 (18 - 12)	0.5 - 1.5 (20 - 16)
	2 x 1 (2 x 18)	2 x 0.5 - 0.75 (2 x 20 - 18)
	0.75 - 6 (18 - 10)	0.5 - 1.5 (20 - 16)
	2 x 0.75 - 2.5 (2 x 18 - 14)	2 x 0.5 - 1.5 (2 x 20 - 16)
	0.75 - 6 (18 - 10)	0.5 - 1.5 (20 - 16)
	2 x 0.75 - 1.5 (2 x 18 - 16)	2 x 0.5 - 1.5 (2 x 20 - 16)
	Pozidrive 1 0.5 Nm max. 4.4 lb-in max.	N.A.
	4 mm 0.5 Nm max. 4.4 lb-in max.	3 mm 0.4 Nm max. 3.5 lb-in max.

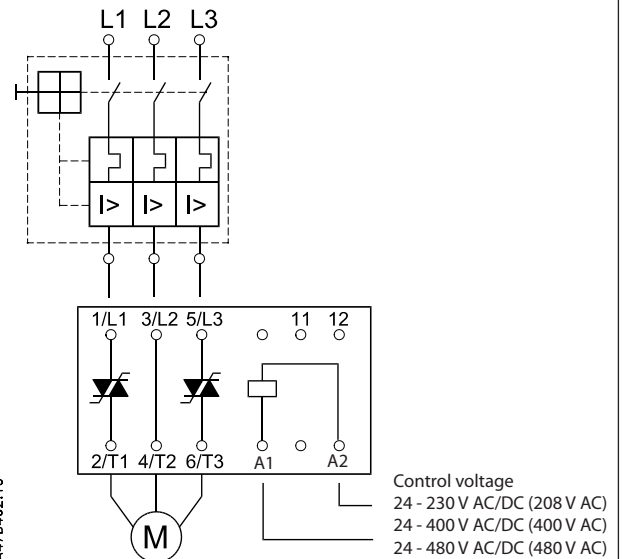

Control voltage  
 24 - 230 V AC/DC (208 V AC)  
 24 - 400 V AC/DC (400 V AC)  
 24 - 480 V AC/DC (480 V AC)

**Do not connect power factor correction capacitors to the output.**

PS.: This product has been designed for class A equipment. Use of the product in domestic environment may cause radio interference, in which case the user may be required to employ additional mitigation methods.

## MCI 15BP Soft Start Motor Controller

### Indstilling - Settings - Einstellungen

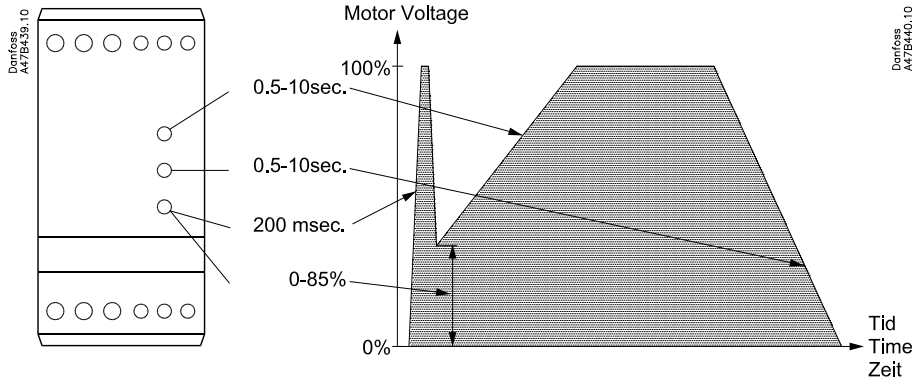

### Bemærkninger - Remarks - Bemerkungen

	Dansk	English	Deutsch
<b>NB!</b>	<ul style="list-style-type: none"> <li>Anvend 2 mm x 0.5 mm skruetrækker.</li> <li>Vær forsigtig ikke at indstille drejekontakterne imellem klik.</li> <li>Motor Controlleren aflæser tid og moment justeringen i stop tilstand.</li> </ul>	<ul style="list-style-type: none"> <li>Use 2 mm x 0.5 mm screwdriver.</li> <li>Make sure that the switches click into position, otherwise time and torque settings will not be correct.</li> <li>The motor controller will read time and torque settings in the off state.</li> <li>Repeated starts may trip motor protection relay.</li> </ul>	<ul style="list-style-type: none"> <li>Schraubenzieher 2 mm x 0.5 mm verwenden.</li> <li>Schalter müssen einrasten, um korrekte Funktion zu gewährleisten.</li> <li>Eingestellte Werte werden im ausgeschalteten Zustand abgelesen.</li> <li>Mehrfache Starts können Motorschutzrelais auslösen.</li> </ul>

### Startmoment indstilling - Initial torque setting - Einstellung der Startleistung

	<ol style="list-style-type: none"> <li>Indstil <b>Ramp-up</b> kontakt til max.</li> <li>indstil <b>Ramp-down</b> kontakt til min.</li> <li>Indstil <b>Initial Torque</b> kontakt til min.</li> <li>Påtryk signalspænding i et par sekunder, hvis ikke motoraksel roterer øjeblikkelig efter start juster <b>Initial torque</b> en deling op. Gentag indtil motoraksel roterer øjeblikkelig efter start.</li> </ol>	<ol style="list-style-type: none"> <li>Set <b>Ramp-up</b> switch to max.</li> <li>Set <b>Ramp-down</b> switch to min.</li> <li>Set <b>Initial torque</b> switch to min.</li> <li>Apply control signal for a few seconds. If the load does not rotate immediately increase the <b>Initial torque</b> for one step and try again. Repeat until the load starts to rotate immediately on start up.</li> </ol>	<ol style="list-style-type: none"> <li><b>Ramp-up</b> Schalter auf max. stellen</li> <li><b>Ramp-down</b> Schalter auf min. stellen</li> <li><b>Initial torque</b> Schalter auf min. stellen</li> <li>Steuersignal einige Sekunden betätigen. Falls der Motor nicht sofort anläuft <b>Initial torque</b> schrittweise erhöhen, bis der Motor anläuft.</li> </ol>
	<p>Hvis <b>Initial torque</b> justeringen ikke er tilstrækkeligt til at starte motoren, er det nødvendigt at anvende <b>Kick-start</b>.</p> <ol style="list-style-type: none"> <li>Indstil <b>Ramp-up</b> tiden til max.</li> <li>Indstil <b>Ramp-down</b> tiden til min.</li> <li>Indstil <b>Initial torque</b> til minimum <b>kick-start</b> moment.</li> <li>Påtryk signalspænding i et par sekunder. Hvis belastningen stopper umiddelbart efter <b>Kick-start</b> perioden juster <b>Initial torque</b> en deling op. Gentag indtil motoraksel fortsætter med at rotere efter <b>Kick-start</b> perioden.</li> </ol>	<p>If the maximum <b>Initial torque</b> setting is not sufficient to start the motor, it is necessary to use <b>Kick-start</b></p> <ol style="list-style-type: none"> <li>Set <b>Ramp-up</b> switch to max.</li> <li>Set <b>Ramp-down</b> switch to min.</li> <li>Set <b>Initial torque</b> switch to min. <b>kick start</b> torque.</li> <li>Apply control signal for a few seconds. If the load stops right after the <b>kick start</b> increase the <b>Initial torque</b> for one step and try again. Repeat until the load continues to rotate after the "kick".</li> </ol>	<p>Falls <b>Initial torque</b> max. Einstellung nicht ausreicht um den Motor zu starten, muß <b>Kick-start</b> verwendet werden.</p> <ol style="list-style-type: none"> <li><b>Ramp-up</b> Schalter auf max. stellen</li> <li><b>Ramp-down</b> Schalter auf min. stellen</li> <li><b>Initial torque</b> Schalter auf min. <b>Kick-start</b> stellen.</li> <li>Steuersignal einige Sekunden betätigen. Falls der Motor sofort wieder stoppt, <b>Initial torque</b> schrittweise erhöhen, bis der Motor sofort nach dem "Kick" anläuft.</li> </ol>

### Start rampe indstilling - Ramp up settings - Einstellung der Startanstiegszeit

	<ol style="list-style-type: none"> <li>Indstil <b>Ramp-up</b> tiden til max. og start motor.</li> <li>Gradvis nedsæt <b>Ramp-up</b> tiden indtil motor og belastning netop overbelastes.</li> <li>Juster <b>Ramp-up</b> tiden en deling op.</li> </ol>	<ol style="list-style-type: none"> <li>Set <b>Ramp-up</b> switch to max. and start motor.</li> <li>Decrease the <b>Ramp-up</b> time until mechanical surge is observed.</li> <li>Increase <b>Ramp-up</b> time one step.</li> </ol>	<ol style="list-style-type: none"> <li><b>Ramp-up</b> Schalter auf max. stellen.</li> <li><b>Ramp-up</b> Zeit solange verkürzen bis Überbelastung beobachtet wird.</li> <li><b>Ramp-up</b> Zeit um einen Schritt erhöhen.</li> </ol>
--	--	--	--

### Stop rampe indstilling - Ramp down settings - Einstellung der Startanstiegszeit

	<ol style="list-style-type: none"> <li>Indstil <b>Ramp-down</b> tiden til max. og afbryd signalspændingen.</li> <li>Gradvis nedsæt <b>Ramp-down</b> tiden indtil motor og belastning netop overbelastes.</li> <li>Juster <b>Ramp-down</b> tiden en deling op.</li> </ol>	<ol style="list-style-type: none"> <li>Set <b>Ramp-down</b> switch to max. and switch off the control voltage.</li> <li>Decrease the <b>Ramp-down</b> time until mechanical surge is observed.</li> <li>Increase <b>Ramp-up</b> time one step.</li> </ol>	<ol style="list-style-type: none"> <li><b>Ramp-down</b> Schalter auf max. stellen und Steuersignal ausschalten.</li> <li><b>Ramp-down</b> Zeit solange verkürzen bis Überbelastung beobachtet wird.</li> <li><b>Ramp-down</b> Zeit um einen Schritt erhöhen.</li> </ol>
--	--	---	---