



NXL FREQUENCY CONVERTERS

**MULTI-PURPOSE APPLICATION
USER'S MANUAL**

MULTI-PURPOSE APPLICATION FOR NXL (SOFTWARE ALFIFFO6) VER. 1.04

INDEX

Document code: ud01141C
Date edited: 27.05.2008

1.	Introduction	3
2.	Control I/O	4
3.	Parameter lists	5
3.1	Monitoring values (Control keypad: menu M1).....	5
3.2	Basic parameters (Control keypad: Menu P2 → P2.1).....	6
3.3	Input signals (Control keypad: Menu P2 → P2.2)	8
3.4	Output signals (Control keypad: Menu P2 → P2.3)	11
3.5	Drive control parameters (Control keypad: Menu P2 → P2.4).....	13
3.6	Prohibit frequency parameters (Control keypad: Menu P2 → P2.5)	13
3.7	Motor control parameters (Control keypad: Menu P2 → P2.6)	14
3.8	Protections (Control keypad: Menu P2 → P2.7)	15
3.9	Autorestart parameters (Control keypad: Menu P2 → P2.8).....	16
3.10	Speed reference parameters (Control keypad: Menu P2 → P2.9).....	16
3.11	Mechanical brake parameters (Control keypad: Menu P2 → P2.10).....	17
3.12	Fieldbus control parameters (Control keypad: Menu P2 → P2.11)	17
3.13	Keypad control (Control keypad: Menu K3)	18
3.14	System menu (Control keypad: Menu S6).....	18
3.15	Expander boards (Control keypad: Menu E7)	18
4.	Description of parameters	19
4.1	BASIC PARAMETERS	19
4.2	INPUT SIGNALS	24
4.3	OUTPUT SIGNALS	29
4.4	DRIVE CONTROL	33
4.5	PROHIBIT FREQUENCIES.....	37
4.6	MOTOR CONTROL	38
4.7	PROTECTIONS.....	42
4.8	AUTO RESTART PARAMETERS	50
4.9	SPEED REFERENCE PARAMETERS.....	52
4.10	MECHANICAL BRAKE PARAMETERS	53
4.11	FIELDBUS CONTROL PARAMETERS	54
4.12	KEYPAD CONTROL PARAMETERS	55

Multi-purpose Application

1. INTRODUCTION

The NXL Multi-purpose application is based on the NXL Multi-Control application. PID and PFC functions have been removed to get free memory space for other functions.

This application allows the use of I/O boards in both expander board slots (D, E). For example, a combination of OPT-AA (E-slot) and OPT-B5 (D-slot) can be used.

Identification of U/f curve parameters and measuring of the stator resistance is realized in this application to make the motor tuning easier.

Features

- Identification without run (U/f curve and Rs voltage drop)
- All inputs functions can be assigned to any input terminal
- All outputs are programmable
- 8 preset speeds
- Mechanical brake control parameters
- Parameter selections for output data to Fieldbus
- Faster IO response
- Current limit by Analogue input or from fieldbus
- Indication when current limit is reached to programmable output
- Second ramp set selected by digital input
- Specific ramp for fast stop activated by digital input
- Analogue input AI1 and AI2 can be used as digital inputs
- Analogue output can be used as digital output
- Support for use of I/O expander board (OPT-Bx) in second extension slot (D)
- Ability to switch from fieldbus reference to preset speed as FB-fault response

2. CONTROL I/O

Reference potentiometer

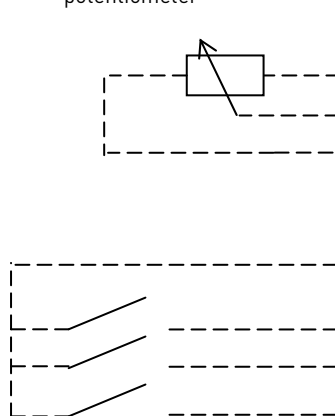

Terminal	Signal	Description
1	+10V _{ref}	Reference output Voltage for potentiometer, etc.
2	AI1+	Analogue input, voltage range 0–10V DC. Voltage input frequency reference Can be programmed as DIN4
3	AI1-	I/O Ground Ground for reference and controls
4	AI2+	Analogue input, voltage range 0–10V DC, or current range 0/4–20mA Current input frequency reference
5	AI2- /GND	
6	+24V	Control voltage output Voltage for switches, etc. max 0.1 A
7	GND	I/O ground Ground for reference and controls
8	DIN1	Start forward Contact closed = start forward
9	DIN2	Start reverse (programmable) Contact closed = start reverse
10	DIN3	Fault Reset (programmable) Contact closed = Fault reset
11	GND	I/O ground Ground for reference and controls
18	A01+	Output frequency Range 0–20 mA/R _L , max. 500Ω
19	A01-	
A	RS 485	Serial bus Differential receiver/transmitter
B	RS 485	Serial bus Differential receiver/transmitter
30	+24V	24V aux. input voltage Control power supply backup
21	RO1	Relay output 1 FAULT
22	RO1	
23	RO1	

Table 1- 1. Multi-purpose application default I/O configuration.

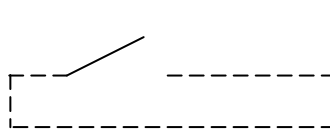

Terminal	Signal	Description
1	+10V _{ref}	Reference output Voltage for potentiometer, etc.
2	AI1+ or DIN 4	Analogue input, voltage range 0–10V DC Voltage input frequency reference (MF2-3) Voltage/current input frequency reference (MF4-MF6) Can be programmed as DIN4
3	AI1-	I/O Ground Ground for reference and controls
4	AI2+	Analogue input, current range 0–20mA Current input frequency reference
5	AI2- /GND	
6	+ 24 V	Control voltage output
7	GND	I/O ground Ground for reference and controls

Table 1- 2. AI1 configuration, when programmed as DIN4

3. PARAMETER LISTS

On the next pages you will find the lists of parameters within the respective parameter groups. Each parameter includes a link to the respective parameter description. The parameter descriptions are given on pages 19 to 55.

Column explanations:

Code	=	Location indication on the keypad; Shows the operator the present param. number
Parameter	=	Name of parameter
Min	=	Minimum value of parameter
Max	=	Maximum value of parameter
Unit	=	Unit of parameter value; Given if available
Default	=	Value preset by factory
Cust	=	Customer's own setting
ID	=	ID number of the parameter (used with PC tools)
	=	On the parameter code: parameter value can only be changed after the FC has been stopped.

3.1 Monitoring values (Control keypad: menu M1)

The monitoring values are the actual values of parameters and signals as well as statuses and measurements. Monitoring values cannot be edited.

See Vacon NXL User's Manual, Chapter 7.4.1 for more information.

Code	Parameter	Unit	ID	Description
V1.1	Output frequency	Hz	1	Frequency to the motor
V1.2	Frequency reference	Hz	25	
V1.3	Motor speed	rpm	2	Calculated motor speed
V1.4	Motor current	A	3	Measured motor current
V1.5	Motor torque	%	4	Calculated actual torque/nom. torque of the motor
V1.6	Motor power	%	5	Calculated actual power/nom. power of the motor
V1.7	Motor voltage	V	6	Calculated motor voltage
V1.8	DC-link voltage	V	7	Measured DC-link voltage
V1.9	Unit temperature	°C	8	Heat sink temperature
V1.10	Analogue input 1		13	AI1
V1.11	Analogue input 2		14	AI2
V1.12	Analogue output current	mA	26	AO1
V1.13	Analogue output current 1, expander board	mA	31	
V1.14	Analogue output current 2, expander board	mA	32	
V1.15	DIN1, DIN2, DIN3		15	Digital input statuses
V1.16	DIE1, DIE2, DIE3		33	I/O expander board: Digital input statuses
V1.17	RO1		34	Relay output 1 status
V1.18	ROE1, ROE2, ROE3		35	I/O exp. board: Relay output statuses
V1.19	DOE 1		36	I/O exp. board: Digital output 1 status
V1.20	Identification status	%	1649	Shows identification status: 0 = Not done 1 = Failed 2 = Successful
V1.21	Motor temperature	%	9	Calculated motor temperature in percent of nominal temperature (0 – 1000%)
V1.22	Input status word	%	56	Input status word. See chapter 4.11

Table 1- 3. Monitoring values

3.2 Basic parameters (Control keypad: Menu P2 → P2.1)

Code	Parameter	Min	Max	Unit	Default	Cust	ID	Note
P2.1.1	Min frequency	0,00	Par. 2.1.2	Hz	0,00		101	
P2.1.2	Max frequency	Par. 2.1.1	320,00	Hz	50,00		102	NOTE: If f_{max} > than the motor synchronous speed, check suitability for motor and drive system
P2.1.3	Acceleration time 1	0,1	3000,0	s	1,0		103	
P2.1.4	Deceleration time 1	0,1	3000,0	s	1,0		104	
P2.1.5	Current limit	$0,1 \times I_L$	$1,5 \times I_L$	A	I_L		107	NOTE: Formulas apply approximately for frequency converters up to MF3. For greater sizes, consult the factory.
P2.1.6	Nominal voltage of the motor	180	690	V	NXL2:230v NXL5:400v		110	
P2.1.7	Nominal frequency of the motor	30,00	320,00	Hz	50,00		111	Check the rating plate of the motor
P2.1.8	Nominal speed of the motor	100	20 000	rpm	1440		112	The default applies for a 4-pole motor and a nominal size frequency converter.
P2.1.9	Nominal current of the motor	$0,3 \times I_L$	$1,5 \times I_L$	A	I_L		113	Check the rating plate of the motor
P2.1.10	Motor cosφ	0,30	1,00		0,85		120	Check the rating plate of the motor
P2.1.11	Start function	0	1		0		505	0=Ramp 1=Flying start
P2.1.12	Stop function	0	1		0		506	0=Coasting 1=Ramp
P2.1.13	Fast stop deceleration time	0,1	3000,0	s	1,0		1600	Deceleration time selection when the fast stop input (P2.2.17) is in use
P2.1.14	I/O reference	0	9		0		117	0=A11 1=A12 2=Keypad reference 3=Fieldbus reference (FBSpeedReference) 4=Motor potentiometer 5=Internal reference (preset speed 0) 6= Max (A11, A12) 7= Min (A11, A12) 8= A11 + A12 9= A11 - A12
P2.1.15	A12 signal range	1	4		2		390	Not used if A12 Custom min <> 0% or A12 custom max. <> 100% 1=0—20 mA 2=4—20 mA 3=0V - 10V 4=2V - 10V

P2.1.16	Analogue output function	0	9		1		307	0=Not used 1=Output freq. (0— f_{max}) 2=Freq. reference (0— f_{max}) 3=Motor speed (0—Motor nominal speed) 4=Output current (0— I_{nMotor}) 5=Motor torque (0— T_{nMotor}) 6=Motor power (0— P_{nMotor}) 7=Mot. voltage (0— U_{nMotor}) 8=DC-link volt (0—1000V) 9=Digital output 2	
P2.1.17	Acceleration time 2	0,1	3000,0	s	10,0		502	Selected by digital input for ramp2 (P2.2.18)	
P2.1.18	Deceleration time 2	0,1	3000,0	s	10,0		503	Selected by digital input for ramp2 (P2.2.18)	
P2.1.19	Start/Stop logic selection	0	2		0		300		
								DIN1	DIN2
								0 Start fwd	Start rvs
1 Start	Reverse								
2 Forward	Stop pulse								

Table 1- 4. Basic parameters P2.1

3.3 Input signals (Control keypad: Menu P2 → P2.2)

Code	Parameter	Min	Max	Unit	Default	Cust	ID	Note
P2.2.1	Start signal 1	0	14		1		403	0=Not used 1=DIN1 2=DIN2 3=DIN3 4=DIN4 (A11) 5=DIN5 (A12) 6=DIE1 7=DIE2 8=DIE3 9=DIE2_1 10=DIE2_2 11=DIE2_3 12=DIE2_4 13=DIE2_5 14=DIE2_6
P2.2.2	Start signal 2	0	14		2		404	As par. 2.2.1,
P2.2.3	External fault close	0	14		4		405	Digital input selection for activating of external fault (NO). See P2.2.1
P2.2.4	External fault open	0	14		0		406	Digital input selection for activating of external fault (NC). See P2.2.1
P2.2.5	Run enable	0	14		0		407	Digital input selection for Run Enable. See P2.2.1
P2.2.6	Fault reset	0	14		3		414	Digital input selection for Fault Reset. See P2.2.1
P2.2.7	Preset speed B0	0	14		6		419	Digital input for binary speed selection B0. See P2.2.1 NOTE: Preset speed input overrides other selected references
P2.2.8	Preset speed B1	0	14		7		420	Digital input for binary speed selection B1. See P2.2.1 NOTE: Preset speed input overrides other selected references
P2.2.9	Preset speed B2	0	14		8		421	Digital input for binary speed selection B2. See P2.2.1 NOTE: Preset speed input overrides other selected references
P2.2.10	Motor potentiometer UP	0	14		0		418	Digital input selection for Motor potentiometer up. See P2.2.1
P2.2.11	Motor potentiometer DOWN	0	14		0		417	Digital input selection for Motor potentiometer down. See P2.2.1
P2.2.12	Thermistor function	0	14		2		1610	Digital input selection for Thermistor function. See P2.2.1
P2.2.13	Force control to I/O terminal	0	14		0		409	Digital input selection for forcing control place to I/O. See P2.2.1
P2.2.14	Force control to fieldbus	0	14		0		411	Digital input selection for forcing control place to fieldbus. See P2.2.1

P2.2.15	DC braking selection	0	14		0		416	Digital input selection for activating of DC-brake in stop mode. See P2.2.1
P2.2.16	AI2 reference	0	14		0		422	Digital input selection for activating AI2 as reference regardless of control place. See P2.2.1 NOTE: Preset speed inputs have higher priority
P2.2.17	Fast stop selection	0	14		0		1611	Digital input selection for fast stop function (P2.1.13). See P2.2.1
P2.2.18	Ramp 2 selection	0	14		0		408	Digital input selection for ramp 2 activation (uses P2.1.17 and P2.1.18). See P2.2.1
P2.2.19	AI1 signal selection	0	39		10		377	10=AI1 (1=Local, 0=input 1) 11=AI2 (1=Local, 1= input 2) 20=Exp. AI1 in E-slot 21=Exp. AI2 in E-slot 30=Exp. AI1 in D-slot 31=Exp. AI2 in D-slot
P2.2.20	AI1 signal range	1	4		3		379	0=Digital input 4 1=0mA – 20mA (MF4-->) 2=4mA – 20mA (MF4-->) 3=0V – 10V 4=2V – 10V Not used if AI2 Custom min > 0% or AI2 custom max. < 100% Note! See NXL User's manual, chapter 7.3.6: AI1 mode
P2.2.21	AI1 custom minimum setting	0,00	100,00	%	0,00		380	
P2.2.22	AI1 custom maximum setting	0,00	100,00	%	100,00		381	
P2.2.23	AI1 inversion	0	1		0		387	0=Not inverted 1=Inverted
P2.2.24	AI1 filter time	0,00	10,00	s	0,10		378	0=No filtering
P2.2.25	AI2 signal selection	0	39		11		388	As par. 2.2.5
P2.2.26	AI2 signal range	1	4		2		390	Not used if AI2 Custom min <> 0% or AI2 custom max. <> 100% 1=0–20 mA 2=4–20 mA 3=0V – 10V 4=2V – 10V
P2.2.27	AI2 custom minimum setting	0,00	100,00	%	0,00		391	
P2.2.28	AI2 custom maximum setting	0,00	100,00	%	100,00		392	
P2.2.29	AI2 inversion	0	1		0		398	0=Not inverted 1=Inverted
P2.2.30	AI2 filter time	0,00	10,00	s	0,10		389	0=No filtering

P2.2.31	Motor potentiometer frequency reference memory reset	0	2		1		367	0=No reset 1=Reset if stopped or powered down 2=Reset if powered down
P2.2.32	Reference scaling minimum value	0,00	P2.2.19		0,00		344	Does not affect the fieldbus reference (Scaled between par. 2.1.1 and par. 2.1.2)
P2.2.33	Reference scaling maximum value	P2.2.18	320,00		0,00		345	Does not affect the fieldbus reference (Scaled between par. 2.1.1 and par. 2.1.2)
P2.2.34	Keypad control reference selection	0	5		2		121	0=A11 1=A12 2=Keypad reference 3=Fieldbus reference (FBSpeedreference) 4=Motor potentiometer 5=PID controller
P2.2.35	Fieldbus control reference selection	0	5		3		122	See above
P2.2.36	Current limit selection	0	3		0		1612	Signal selection for scaling of Current limit (P2.1.5) 0=Not used 1=A11 2=A12 3=Fieldbus

Table 1- 5. Input signals, P2.2

CP=control place
cc=closing contact
oc=opening contact

3.4 Output signals (Control keypad: Menu P2 → P2.3)

Code	Parameter	Min	Max	Unit	Default	Cust	ID	Note
P2.3.1	Relay output 1 function	0	18		3		313	0=Not used 1=Ready 2=Run 3=Fault 4=Fault inverted 5=FC overheat warning 6=Ext. fault or warning 7=Ref. fault or warning 8=Warning 9=Reversed 10=Preset speed 11=At speed 12=Mot. regulator active 13=OP freq. limit superv.1 14=Control place: IO 15=Thermistor fault/ warning 16=Current Limit active 17=Mechanical brake control 18=AI supervision active
P2.3.2	Digital output 2 function	0	18		0		490	As parameter 2.3.1
P2.3.3	Expander board relay output 1 function	0	18		2		314	As parameter 2.3.1
P2.3.4	Expander board relay output 2 function	0	18		3		317	As parameter 2.3.1
P2.3.5	Expander board digital output/RO3 1 function	0	18		1		312	As parameter 2.3.1
P2.3.6	Expander board 2 RO1/DO1 function	0	18		0		1620	Function selection for expander board digital/relay output 1. See par. 2.3.1
P2.3.7	Expander board 2 RO2/DO2 function	0	18		0		1621	Function selection for expander board digital/relay output 2
P2.3.8	Expander board 2 RO3/DO3 function	0	18		0		1622	Function selection for expander board digital/relay output 3. See par. 2.3.1
P2.3.9	Expander board 2 RO4/DO4 function	0	18		0		1623	Function selection for expander board digital/relay output 4. See par. 2.3.1
P2.3.10	Expander board 2 RO5/DO5 function	0	18		0		1624	Function selection for expander board digital/relay output 5. See par. 2.3.1
P2.3.11	Expander board 2 RO6/DO6 function	0	18		0		1625	Function selection for expander board digital/relay output 6. See par. 2.3.1
P2.3.12	Analogue output function	0	12		1		307	See par. 2.1.16
P2.3.13	Analogue output filter time	0,00	10,00	s	1,00		308	0=No filtering
P2.3.14	Analogue output inversion	0	1		0		309	0=Not inverted 1=Inverted
P2.3.15	Analogue output minimum	0	1		0		310	0=0 mA 1=4 mA
P2.3.16	Analogue output scale	10	1000	%	100		311	
P2.3.17	Expander board analogue output 1 function	0	12		0		472	As parameter 2.1.16
P2.3.18	Expander board analogue output 2 function	0	12		0		479	As parameter 2.1.16

P2.3.19	Output frequency limit 1 supervision	0	2		0		315	0=No limit 1=Low limit supervision 2=High limit supervision
P2.3.20	Output frequency limit 1; Supervised value	0,00	Par. 2.1.2	Hz	0,00		316	
P2.3.21	Analogue input supervision	0	2		0		356	0=Not used 1=A11 2=A12
P2.3.22	AI supervision OFF limit	0,00	100,00	%	10,00		357	
P2.3.23	AI supervision ON limit	0,00	100,00	%	90,00		358	
P2.3.24	Relay output 1 ON delay	0,00	320,00	s	0,00		487	ON delay for R01
P2.3.25	Relay output 1 OFF delay	0,00	320,00	s	0,00		488	OFF delay for R01

Table 1- 6. Output signals, G2.3

3.5 Drive control parameters (Control keypad: Menu P2 → P2.4)

Code	Parameter	Min	Max	Unit	Default	Cust	ID	Note
P2.4.1	Ramp 1 shape	0,0	10,0	s	0,0		500	0=Linear >0=S-curve ramp time
P2.4.2	Brake chopper	0	3		0		504	0=Disabled 1=Used in Run state 3=Used in Run and Stop state
P2.4.3	DC braking current	$0,15 \times I_n$	$1,5 \times I_n$	A	Varies		507	
P2.4.4	DC braking time at stop	0,00	600,00	s	0,00		508	0=DC brake is off at stop
P2.4.5	Frequency to start DC braking during ramp stop	0,10	10,00	Hz	1,50		515	
P2.4.6	DC braking time at start	0,00	600,00	s	0,00		516	0=DC brake is off at start
P2.4.7	Flux brake	0	1		0		520	0=Off 1=On
P2.4.8	Flux braking current	0,0	Varies	A	0,0		519	

Table 1- 7. Drive control parameters, P2.4

3.6 Prohibit frequency parameters (Control keypad: Menu P2 → P2.5)

Code	Parameter	Min	Max	Unit	Default	Cust	ID	Note
P2.5.1	Prohibit frequency range 1 low limit	0,0	Par. 2.5.2	Hz	0,0		509	0=Not used
P2.5.2	Prohibit frequency range 1 high limit	0,0	Par. 2.1.2	Hz	0,0		510	0=Not used
P2.5.3	Prohibit frequencies acc./dec. ramp scaling	0,1	10,0	Times	1,0		518	Multiplier of the currently selected ramp time between prohibit frequency limits

Table 1- 8. Prohibit frequency parameters, P2.5

3.7 Motor control parameters (Control keypad: Menu P2 → P2.6)

Code	Parameter	Min	Max	Unit	Default	Cust	ID	Note
P2.6.1	Motor control mode	0	1		0		600	0=Frequency control 1=Speed control
P2.6.2	U/f optimisation	0	1		0		109	0=Not used 1=Automatic torque boost
P2.6.3	U/f ratio selection	0	3		0		108	0=Linear 1=Squared 2=Programmable 3=Linear with flux optim.
P2.6.4	Field weakening point	30,00	320,00	Hz	50,00		602	
P2.6.5	Voltage at field weakening point	10,00	200,00	%	100,00		603	n% x U _{nmot}
P2.6.6	U/f curve midpoint frequency	0,00	par. P2.6.3	Hz	50,00		604	
P2.6.7	U/f curve midpoint voltage	0,00	100,00	%	100,00		605	n% x U _{nmot} Parameter max. value = par. 2.6.4
P2.6.8	Output voltage at zero frequency	0,00	40,00	%	0,00		606	n% x U _{nmot}
P2.6.9	Switching frequency	1,0	16,0	kHz	6,0		601	Depends on kW
P2.6.10	Overvoltage controller	0	1		1		607	0=Not used 1=Used
P2.6.11	Undervoltage controller	0	1		1		608	0=Not used 1=Used
P2.6.12	Rs voltage drop	0	30000		0		662	
P2.6.13	Identification	0	1		0		631	0=No action 1=ID no run

Table 1- 9. Motor control parameters, P2.6

3.8 Protections (Control keypad: Menu P2 → P2.7)

Code	Parameter	Min	Max	Unit	Default	Cus t	ID	Note
P2.7.1	Response to 4mA reference fault	0	3		0		700	0=No response 1=Warning 2=Fault,stop acc. to 2.1.12 3=Fault,stop by coasting
P2.7.2	Response to external fault	0	3		2		701	0=No response 1=Warning 2=Fault,stop acc. to 2.1.12 3=Fault,stop by coasting
P2.7.3	Response to undervoltage fault	1	3		2		727	
P2.7.4	Output phase supervision	0	3		2		702	
P2.7.5	Earth fault protection	0	3		2		703	
P2.7.6	Thermal protection of the motor	0	3		2		704	
P2.7.7	Motor ambient temperature factor	-100,0	100,0	%	0,0		705	
P2.7.8	Motor cooling factor at zero speed	0,0	150,0	%	40,0		706	
P2.7.9	Motor thermal time constant	1	200	min	45		707	
P2.7.10	Motor duty cycle	0	100	%	100		708	
P2.7.11	Stall protection	0	3		1		709	As par. 2.7.1
P2.7.12	Stall current limit	0,1	$I_{n\text{motor}} \times 2$	A	$I_{n\text{motor}} \times 1.3$		710	
P2.7.13	Stall time limit	1,00	120,00	s	15,00		711	
P2.7.14	Stall frequency limit	1,0	P 2.1.2	Hz	25,0		712	
P2.7.15	Underload protection	0	3		0		713	As par. 2.7.1
P2.7.16	Underload curve at nominal frequency	10,0	150,0	%	50,0		714	
P2.7.17	Underload curve at zero frequency	5,0	150,0	%	10,0		715	
P2.7.18	Underload protection time limit	2,00	600,00	s	20,00		716	
P2.7.19	Response to thermistor fault	0	3		2		732	As par. 2.7.1
P2.7.20	Response to fieldbus fault	0	3		2		733	0=No response 1=Warning 2=Fault,stop acc. to 2.1.12 3=Fault,stop by coasting 4=Warning, Preset speed 2.7.22
P2.7.21	Response to slot fault	0	3		2		734	0=No response 1=Warning 2=Fault,stop acc. to 2.1.12 3=Fault,stop by coasting 4=Warning, Preset speed 2.7.22
P2.7.22	FB Fault frequency	0	320,00	Hz	50,00		1650	Frequency used as reference for 2.7.20 and 2.7.21

Table 1- 10. Protections, P2.7

3.9 Autorestart parameters (Control keypad: Menu P2 → P2.8)

Code	Parameter	Min	Max	Unit	Default	Cust	ID	Note
P2.8.1	Automatic restart	0	1		0		731	0=Not used 1=Used
P2.8.2	Wait time	0,10	10,00	s	0,50		717	
P2.8.3	Trial time	0,00	60,00	s	30,00		718	
P2.8.4	Start function	0	2		0		719	0=Ramp 1=Flying start 2=According to par. 2.4.6

Table 1- 11. Autorestart parameters, P2.8

3.10 Speed reference parameters (Control keypad: Menu P2 → P2.9)

Code	Parameter	Min	Max	Unit	Default	Cust	ID	Note
P2.9.1	Preset speed 0	0,00	Par. 2.1.2	Hz	5,00		124	Used if P2.1.14 = 5 and other preset speed inputs are off
P2.9.2	Preset speed 1	0,00	Par. 2.1.2	Hz	10,00		105	
P2.9.3	Preset speed 2	0,00	Par. 2.1.2	Hz	15,00		106	
P2.9.4	Preset speed 3	0,00	Par. 2.1.2	Hz	20,00		126	
P2.9.5	Preset speed 4	0,00	Par. 2.1.2	Hz	25,00		127	
P2.9.6	Preset speed 5	0,00	Par. 2.1.2	Hz	30,00		128	
P2.9.7	Preset speed 6	0,00	Par. 2.1.2	Hz	40,00		129	
P2.9.8	Preset speed 7	0,00	Par. 2.1.2	Hz	50,00		130	

Table 1- 12. Speed reference parameters, P2.9

3.11 Mechanical brake parameters (Control keypad: Menu P2 → P2.10)

Code	Parameter	Min	Max	Unit	Default	Cust	ID	Note
P2.10.1	Current limit, brake open	0,00	par. 2.1.9	A	0,00		1700	Motor current limit for allowing the mechanical brake to open.
P2.10.2	Frequency limit, brake open	0,00	par. 2.1.7	Hz	0,00		1704	Output frequency limit for allowing the mechanical brake to open.
P2.10.3	Brake open delay	0,00	10,00	s	0,00		1706	Delay for opening the mechanical brake after limits set with parameters 2.10.1 and 2.10.2 have been reached
P2.10.4	Frequency limit, brake close	0,01	par. 2.1.7		0,00		1707	Output frequency limit for closing the mechanical brake during a ramp stop
P2.10.5	Brake close delay	0,00	10,00	s	0,00		1708	Delay for closing the mechanical brake after the limit set with par. 2.10.4 has been reached

Table 1- 13. Mechanical brake parameters, P2.10

3.12 Fieldbus control parameters (Control keypad: Menu P2 → P2.11)

Code	Parameter	Min	Max	Unit	Default	Cust	ID	Note
P2.11.1	Fieldbus min scale	0,00	320,00	Hz	0,00		850	
P2.11.2	Fieldbus max scale	0,00	320,00	Hz	0,00		851	
P2.11.3	Fieldbus data out 1 selection	0	14		1		852	Selection of output data to fieldbus process data 1 0 =Output frequency 1 =Motor speed 2 =Motor current 3 =Motor torque 4 =Motor power 5 =Motor voltage 6 =DC-link voltage 7 =Fault code 8 =Frequency reference 9 =Unit temperature 10 =Motor temperature 11 =AI1 12 =AI2 13 =Input status word (Binary, see bit descriptions on page 54) 14 =Output status word (Binary, see bit descriptions on page 54)
P2.11.4	Fieldbus data out 2 selection	0	14		1		853	See par. 2.11.1
P2.11.5	Fieldbus data out 3 selection	0	14		1		854	See par. 2.11.1
P2.11.6	Fieldbus data out 4 selection	0	14		1		855	See par. 2.11.1

Table 1- 14. Fieldbus control parameters

3.13 Keypad control (Control keypad: Menu K3)

The parameters for the selection of control place and direction on the keypad are listed below. See the Keypad control menu in the Vacon NXL User's Manual.

Code	Parameter	Min	Max	Unit	Default	Cust	ID	Note
P3.1	Control place	1	3		1		125	1 = I/O terminal 2 = Keypad 3 = Fieldbus
R3.2	Keypad reference	Par. 2.1.1	Par. 2.1.2	Hz				
P3.3	Direction (on keypad)	0	1		0		123	0 = Forward 1 = Reverse
R3.4	Stop button	0	1		1		114	0=Limited function of Stop button 1=Stop button always enabled

Table 1- 15. Keypad control parameters, M3

3.14 System menu (Control keypad: Menu S6)

For parameters and functions related to the general use of the frequency converter, such as customised parameter sets or information about the hardware and software, see Chapter 7.4.6 in the Vacon NXL User's Manual.

3.15 Expander boards (Control keypad: Menu E7)

The E7 menu shows the expander boards attached to the control board and board-related information. For more information, see Chapter 7.4.7 in the Vacon NXL User's Manual.

4. DESCRIPTION OF PARAMETERS

4.1 BASIC PARAMETERS

2.1.1, 2.1.2 *Minimum/maximum frequency*

Defines the frequency limits of the frequency converter.

The maximum value for parameters 2.1.1 and 2.1.2 is 320 Hz.

The software will automatically check the values of parameters [2.1.19](#), [2.1.20](#), [2.3.13](#), [2.5.1](#), [2.5.2](#) and [2.6.5](#).

2.1.3, 2.1.4 *Acceleration time 1, deceleration time 1*

These limits correspond to the time required for the output frequency to accelerate from the zero frequency to the set maximum frequency (par. 2.1.2).

2.1.5 *Current limit*

This parameter determines the maximum motor current from the frequency converter. To avoid motor overload, set this parameter according to the rated current of the motor. The current limit is equal to the rated converter current (I_L) by default.

NOTE: It is possible to adjust the current limit by AI1, AI2 or FB process data in 1 (see par. [2.2.36](#))

2.1.6 *Nominal voltage of the motor*

Find this value U_n on the rating plate of the motor. This parameter sets the voltage at the field weakening point ([parameter 2.6.4](#)) to $100\% \times U_{n\text{motor}}$.

2.1.7 *Nominal frequency of the motor*

Find this value f_n on the rating plate of the motor. This parameter sets the field weakening point ([parameter 2.6.3](#)) to the same value.

2.1.8 *Nominal speed of the motor*

Find this value n_n on the rating plate of the motor.

2.1.9 *Nominal current of the motor*

Find this value I_n on the rating plate of the motor.

2.1.10 *Motor cos phi*

Find this value "cos phi" on the rating plate of the motor.

2.1.11 Start function

Ramp:

- 0 The frequency converter starts from 0 Hz and accelerates to maximum frequency within the set [acceleration time](#). (Load inertia or starting friction may cause prolonged acceleration times).

Flying start:

- 1 The frequency converter is able to start into a running motor by applying a small torque to motor and searching for the frequency corresponding to the speed the motor is running at. The searching starts from the maximum frequency towards the actual frequency until the correct value is detected. Thereafter, the output frequency will be increased/decreased to the set reference value according to the set acceleration/deceleration parameters.

Use this mode if the motor is coasting when the start command is given. With the flying start, it is possible to ride through short mains voltage interruptions.

2.1.12 Stop function

Coasting:

- 0 The motor coasts to a halt without control from the frequency converter after the Stop command.

Ramp:

- 1 After the Stop command, the speed of the motor is decelerated according to the set deceleration parameters.

If the regenerated energy is high it may be necessary to use an external braking resistor for faster deceleration.

2.1.13 *Fast stop deceleration time*

Deceleration time used when the fast stop input (P2.2.17) is in use.

2.1.14 *I/O Reference selection*

Defines the selected frequency reference source when the drive is controlled from the I/O terminal.

- 0 AI1 reference (terminals 2 and 3, e.g. potentiometer)
- 1 AI2 reference (terminals 5 and 6, e.g. transducer)
- 2 Keypad reference (parameter 3.2)
- 3 Reference from Fieldbus (FBSpeedReference)
- 4 Motor potentiometer reference
- 5 Internal reference (Preset Speed 0, P2.9.1)
- 6 Max (AI1, AI2)
- 7 Min (AI1, AI2)
- 8 AI1 + AI2
- 9 AI1 – AI2

2.1.15 *AI2 (I_{in}) signal range*

- 1 Signal range 0...20 mA
- 2 Signal range 4...20 mA
- 3 Signal range 0...10V
- 4 Signal range 2...10V

Note! The selections have no effect if par. 2.2.12 > 0%, or par. 2.2.13 < 100%.

2.1.16 *Analogue output function*

This parameter selects the desired function for the analogue output signal. See the table on page 7 for the parameter values.

NOTE! If the value of this parameter = 9 (digital output 2), select the output function with [par. 2.3.2](#).

2.1.17, 2.1.18 *Acceleration time 2, deceleration time 2*

These limits correspond to the time required for the output frequency to accelerate from the zero frequency to the set maximum frequency (par. 2.1.2).

2.1.19 Start/stop logic selection

- 0 Start Signal 1(DIN1) : closed contact = start forward
Start Signal 2(DIN2) : closed contact = start reverse

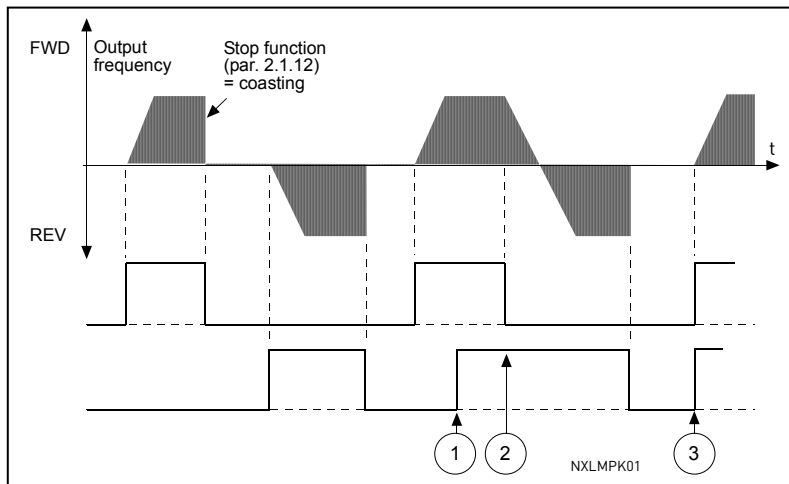

Figure 1- 1. Start forward/Start reverse

- ① The first selected direction has the highest priority.
- ② When the DIN1 contact opens the direction of rotation starts the change.
- ③ If Start forward (DIN1) and Start reverse (DIN2) signals are active simultaneously the Start forward signal (DIN1) has priority.

- 1 Start Signal 1(DIN1) : closed contact = start open contact = stop
Start Signal 2(DIN2): closed contact = reverse open contact = forward

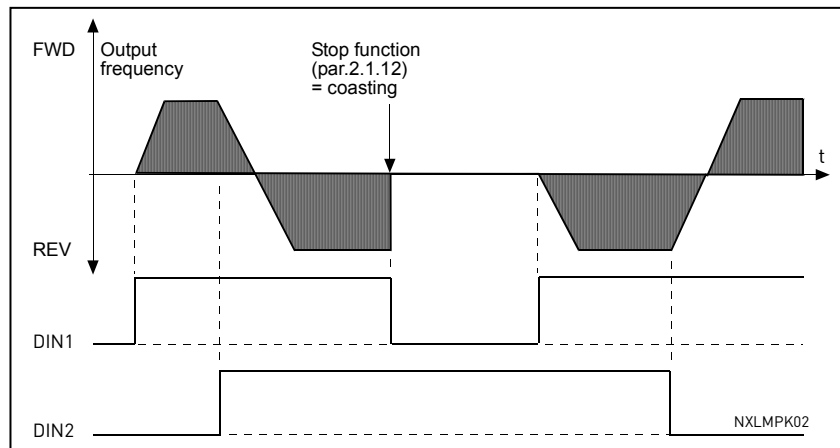

Figure 1- 2. Start, Stop, Reverse

2 3-wire connection (pulse control):

Start Signal 1(DIN1) : closed contact = start pulse (**Rising edge required to start**)

Start Signal 2(DIN2) : open contact = stop pulse

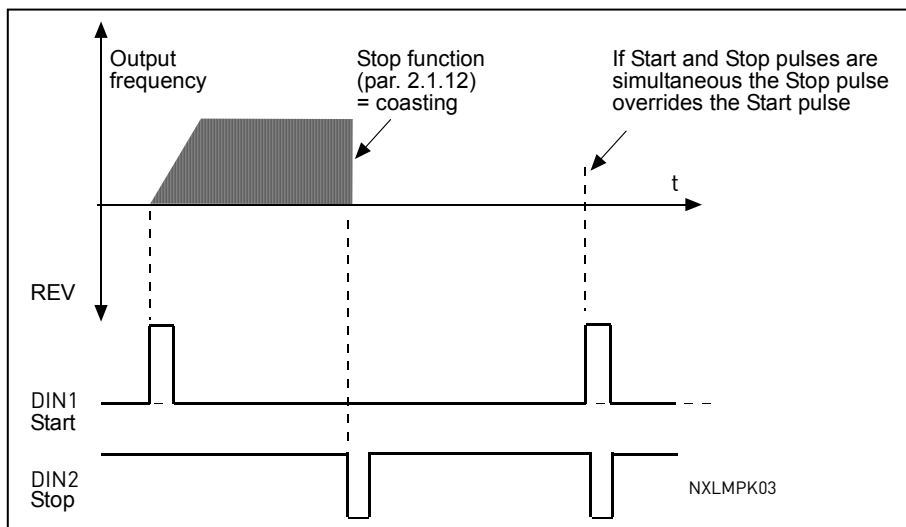

Figure 1- 3. Start pulse, stop pulse

The selection 2 excludes the possibility of an unintentional start when, for example, power is connected, re-connected after a power failure, after a fault reset, after the drive is stopped by Run Enable (Run Enable = False) or when the control place is changed. The Start/Stop contact must be opened before the motor can be started

4.2 INPUT SIGNALS

Input signals can be programmed by selecting an input for a certain function (parameter). the functions (parameters) are as follows:

- 2.2.1, 2.2.2** *Start signal 1 & 2*
- 2.2.3** *External fault close*
- 2.2.4** *External fault open*
- 2.2.5** *Run enable*
- 2.2.6** *Fault reset*
- 2.2.7** *Preset speed B0*
- 2.2.8** *Preset speed B1*
- 2.2.9** *Preset speed B2*
- 2.2.10** *Motor potentiometer UP*
- 2.2.11** *Motor potentiometer DOWN*
- 2.2.12** *Thermistor selection*
- 2.2.13** *Force control to I/O terminal*
- 2.2.14** *Force control to fieldbus*
- 2.2.15** *DC braking selection*
- 2.2.16** *AI2 reference*
- 2.2.17** *Fast stop selection*
- 2.2.18** *Ramp 2 selection*

The following inputs can be selected for these parameters:

0 = Not used
1 = DIN1
2 = DIN2
3 = DIN3
4 = DIN4 (AI1)
5 = DIN5 (AI2)
6 = DIE1 (Expander board DIN1, slot E)
7 = DIE2 (Expander board DIN2, slot E)
8 = DIE3 (Expander board DIN3, slot E)
9 = DIE2_1 (Expander board DIN1, slot D)
10 = DIE2_2 (Expander board DIN2, slot D)
11 = DIE2_3 (Expander board DIN3, slot D)
12 = DIE2_4 (Expander board DIN4, slot D)
13 = DIE2_5 (Expander board DIN5, slot D)
14 = DIE2_6 (Expander board DIN6, slot D)

Table 1- 16. Digital input selections for parameters 2.2.1 – 2.2.18

2.2.19 AI1 signal selection

Connect the AI1 signal to the analogue input of your choice with this parameter.

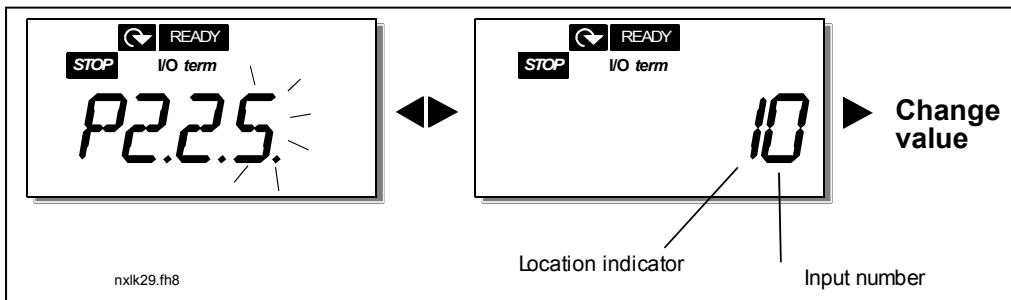

Figure 1- 4. AI1 signal selection

The value of this parameter is formed of the *board indicator* and the *respective input terminal number*. See Figure 1- 2 above.

Board indicator 1	= Local inputs
Board indicator 2	= Expander board inputs
Input number 0	= Input 1
Input number 1	= Input 2
Input number 2	= Input 3
⋮	
Input number 9	= Input 10

Example:

If you set the value of this parameter to **10**, you have selected the local input 1 for the AI1 signal. Again, if the value is set to **21**, the expander board input 2 has been selected for the AI1 signal.

If you want to use the values of analogue input signal for e.g. testing purposes only, you can set the parameter value to **0 - 9**. In this case, value **0** corresponds to **0%**, value **1** corresponds to **20%** and any value between **2** and **9** corresponds to **100%**.

2.2.20 AI1 signal range

With this parameter you can select the AI1 signal range.

- 0 = DIN 4
- 1 = Signal range 0...20mA (only for sizes MF4 and bigger)
- 2 = Signal range 4...20mA (only for sizes MF4 and bigger)
- 3 = Signal range 0...10V
- 4 = Signal range 2...10V

Note! The selections have no effect if par. 2.2.7 > 0%, or par. 2.2.8 < 100%.

If the value of par. 2.2.6 is set to **0**, AI1 functions as digital input 4. See par. 2.2.4

2.2.21 *AI1 custom setting minimum***2.2.22** *AI1 custom setting maximum*

Set the custom minimum and maximum levels for the AI1 signal within 0...10V.

2.2.23 *AI1 signal inversion*

By setting the parameter value to 1 the AI1 signal inversion takes place.

2.2.24 *AI1 signal filter time*

This parameter, given a value greater than 0, activates the function that filters out disturbances from the incoming analogue U_{in} signal.

Long filtering time makes the regulation response slower. See Figure 1- 5

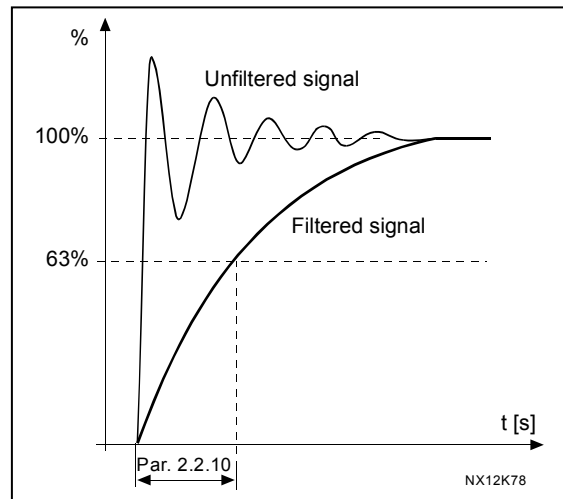

Figure 1- 5. AI1 signal filtering

2.2.25 *AI2 signal selection*

Connect the AI2 signal to the analogue input of your choice with this parameter. See [par. 2.2.5](#) for the value setting procedure.

2.2.26 *AI2 signal range*

- 1 = Signal range 0...20mA
- 2 = Signal range 4...20mA
- 3 = Signal range 0...10V
- 4 = Signal range 2...10V

Note! The selections have no effect if [par. 2.2.13](#) > 0%, or [par. 2.2.14](#) < 100%.

2.2.27 *AI2 custom minimum***2.2.28** *AI2 custom maximum*

These parameters allow you to scale the input current signal between 0 and 20 mA.

Cf. parameters [2.2.7](#) and [2.2.8](#).

2.2.29 *Analogue input AI2 signal inversion*

See corresponding parameter [2.2.9](#).

2.2.30 *Analogue input AI2 signal filter time*

See corresponding parameter [2.2.10](#).

2.2.31 *Motor potentiometer memory reset (Frequency reference)*

0 = No reset

1 = Memory reset in stop and powerdown

2 = Memory reset in powerdown

2.2.32 *Reference scaling minimum value***2.2.33** *Reference scaling maximum value*

You can choose a scaling range for the frequency reference between the [Minimum](#) and [Maximum](#) frequency. If no scaling is desired set the parameter value to 0.

In the figures below, voltage input AI1 with signal range 0...10V is selected for reference.

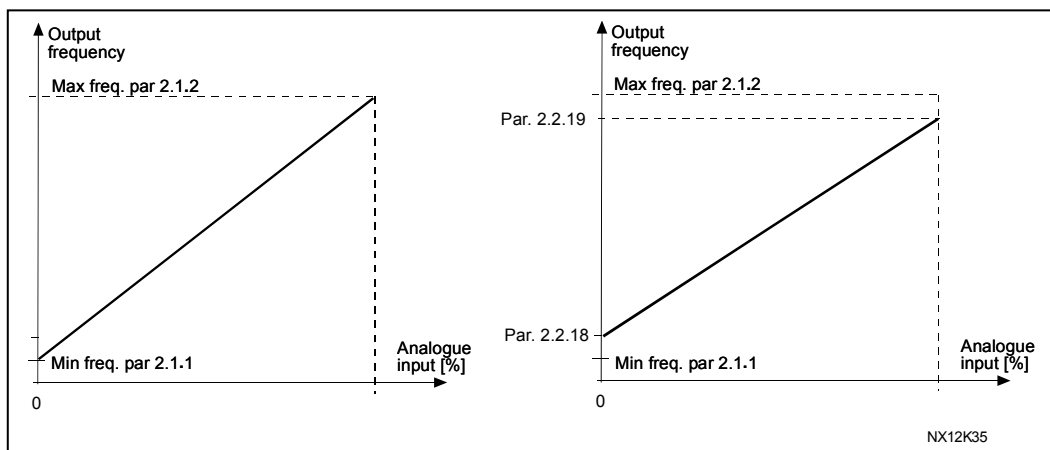

Figure 1- 6. Left: Par. 2.1.18=0 (No reference scaling) Right: Reference scaling

2.2.34 *Keypad frequency reference selection*

Defines the selected reference source when the drive is controlled from the keypad

0 AI1 reference (by default AI1, terminals 2 and 3, e.g. potentiometer)

1 AI2 reference (by default AI2, terminals 5 and 6, e.g. transducer)

2 Keypad reference (parameter 3.2)

3 Reference from Fieldbus (FBSpeedReference)

4 Motor potentiometer reference

5 PID-controller reference

2.2.35 *Fieldbus frequency reference selection*

Defines the selected reference source when the drive is controlled from the fieldbus.

For the parameter values, see [par. 2.2.20](#).

2.2.36 *Current limit scaling selection*

With this parameter the user can select the signal for scaling current limit (par 2.1.5)

The current limit is scaled between 0-100%.

- 0 Not used
- 1 AI1
- 2 AI2
- 3 Fieldbus (scaling range 0=0%, 10000=100.00%)

4.3 OUTPUT SIGNALS

- 2.3.1 *Relay output 1 function*
- 2.3.2 *Digital output 2 (AO1) function*
- 2.3.3 *Expander board relay output 1 function*
- 2.3.4 *Expander board relay output 2 function*
- 2.3.5 *Expander board digital output 1 function*
- 2.3.6 *Expander board 2 digital/relay output 1 function*
- 2.3.7 *Expander board 2 digital/relay output 2 function*
- 2.3.8 *Expander board 2 digital/relay output 3 function*
- 2.3.9 *Expander board 2 digital/relay output 4 function*
- 2.3.10 *Expander board 2 digital/relay output 5 function*
- 2.3.11 *Expander board 2 digital/relay output 6 function*

Setting value	Signal content
0 = Not used	Out of operation
	<u>Relay output R01 and expander board programmable relays (R01, R02) are activated when:</u>
1 = Ready	The frequency converter is ready to operate
2 = Run	The frequency converter operates (motor is running)
3 = Fault	A fault trip has occurred
4 = Fault inverted	A fault trip <u>not</u> occurred
5 = Frequency converter overheat warning	The heat-sink temperature exceeds +70°C
6 = External fault or warning	Fault or warning depending on par. 2.7.2
7 = Reference fault or warning	Fault or warning depending on par. 2.7.1 - if analogue reference is 4–20 mA and signal is <4mA
8 = Warning	Always if a warning exists
9 = Reversed	The reverse command has been selected
10 = Preset speed	A preset speed has been selected
11 = At speed	The output frequency has reached the set reference
12 = Motor regulator activated	Overvoltage or overcurrent regulator was activated
13 = Output frequency limit 1 supervision	The output frequency goes outside the set supervision low limit/high limit (see parameters 2.3.12 and 2.3.13 below)
14 = Control from I/O terminals	Selected control place (Menu K3 ; par. 3.1) is "I/O terminal"
15 = Thermistor fault or warning	The thermistor input of option board indicates overtemperature. Fault or warning depending on parameter 2.7.19 .
16 = Current limit active	Motor current has reached the current limit (P2.1.5)
17 = Mechanical brake control	The mechanical brake is opened when the output is high
18 = AI Supervision active	Configured by parameters P2.3.21-P2.3.23

Table 1- 17. Output signals via R01 and expander board R01, R02 and DO1.

2.3.12 Analogue output function

This parameter selects the desired function for the analogue output signal.

See the table on page 6 for the parameter values.

2.3.13 Analogue output filter time

Defines the filtering time of the analogue output signal.

If you set value 0 for this parameter, no filtering takes place.

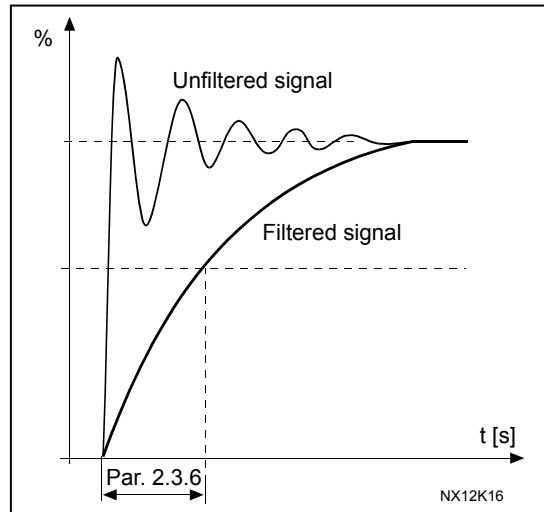

Figure 1- 7. Analogue output filtering

2.3.14 Analogue output invert

Inverts the analogue output signal:

Maximum output signal = 0 %

Minimum output signal = Maximum set value (parameter 2.3.9)

- 0 Not inverted
- 1 Inverted

See parameter 2.3.9 below.

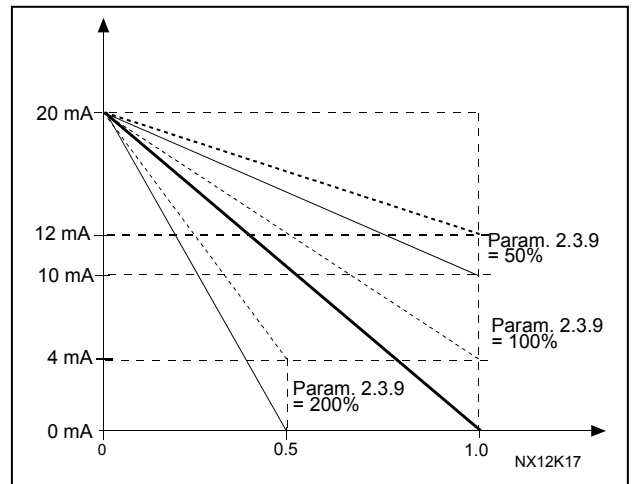

Figure 1- 8. Analogue output invert

2.3.15 Analogue output minimum

Sets the signal minimum to either 0 mA or 4 mA (living zero). Note the difference in the analogue output scaling in parameter 2.3.9.

2.3.16 Analogue output scale

Scaling factor for the analogue output.

Signal	Max. value of the signal
Output frequency	100% x f_{max}
Motor speed	100% x Motor nom. speed
Output current	100% x I_{nMotor}
Motor torque	100% x T_{nMotor}
Motor power	100% x P_{nMotor}
Motor voltage	100% x U_{nMotor}
DC-link voltage	1000 V
PI-ref. value	100% x ref. value max.
PI act. value 1	100% x actual value max.
PI error value	100% x error value max.
PI output	100% x output max.

Table 1- 18. Analogue output scaling

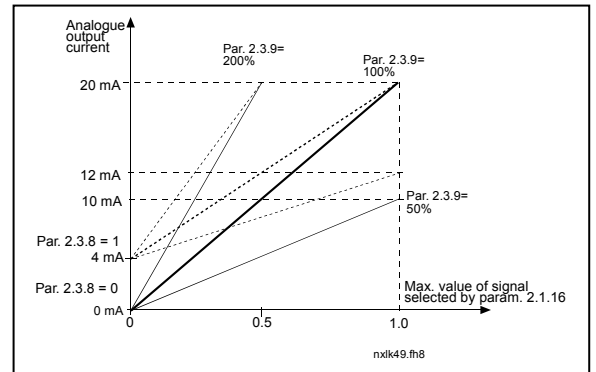

Figure 1- 9. Analogue output scaling

2.3.17 Expander board analogue output 1 function

2.3.18 Expander board analogue output 2 function

These parameters select the desired functions for the expander board analogue output signals. See [par. 2.1.16](#) for the parameter values.

NOTE: These signals are normally addressed to the E-slot but addressing is automatically changed to D-slot if OPT-B4 board is installed in D-slot.

2.3.19 Output frequency limit 1 supervision function

- 0 No supervision
- 1 Low limit supervision
- 2 High limit supervision

If the output frequency goes under/over the set limit ([par. 2.3.13](#)) this function generates a warning message via the relay outputs depending on the settings of parameters [2.3.1](#) – [2.3.4](#).

2.3.20 Output frequency limit 1 supervised value

Selects the frequency value supervised by parameter 2.3.12.

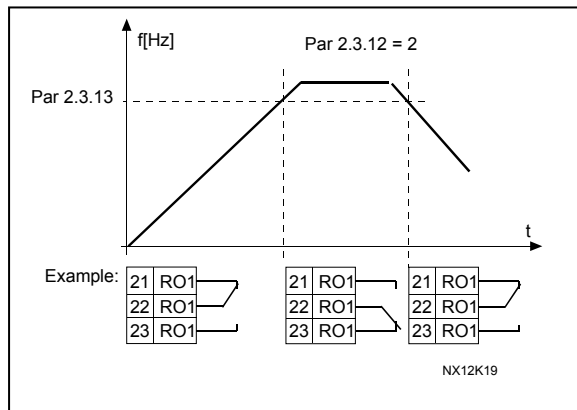

Figure 1- 10. Output frequency supervision

2.3.21 *Analogue input supervision*

With this parameter you can select the analogue input to be supervised.

0 = Not used

1 = AI1

2 = AI2

2.3.22 *Analogue input supervision OFF limit*

When the signal of analogue input selected with par. 2.3.14 falls under the limit set with this parameter, the relay output goes off.

2.3.23 *Analogue input supervision ON limit*

When the signal of analogue input selected with par. 2.3.14 goes over the limit set with this parameter, the relay output goes on.

This means that if for example ON limit is 60% and OFF limit is 40%, the relay goes on when signal goes over 60% and remains on until it falls under 40%.

2.3.24 *Relay output 1 ON delay*

2.3.25 *Relay output 1 OFF delay*

With these parameters you can set on- and off-delays to relay output 1 ([par 2.3.1](#)).

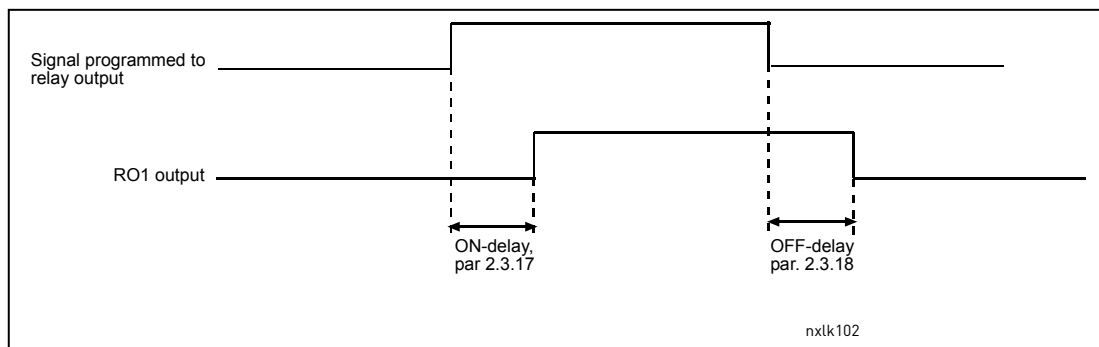

Figure 1- 11. Relay output 1 on- and off-delays

4.4 DRIVE CONTROL

2.4.1 Acceleration/Deceleration ramp 1 shape

The start and end of the acceleration and deceleration ramp can be smoothed with this parameter. Setting value 0 gives a linear ramp shape which causes acceleration and deceleration to act immediately to the changes in the reference signal.

Setting value 0.1...10 seconds for this parameter produces an S-shaped acceleration/deceleration. The acceleration time is determined with parameters [2.1.3/2.1.4](#)

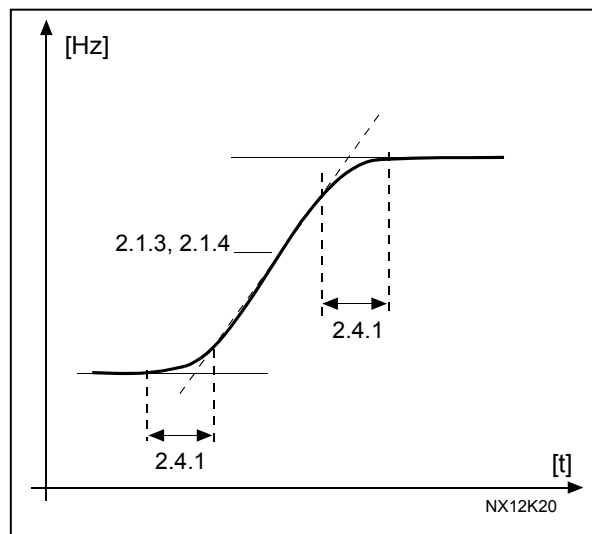

Figure 1-12. Acceleration/Deceleration (S-shaped)

2.4.2 Brake chopper

Note! An internal brake chopper is installed in all other sizes but MF2

- 0 No brake chopper used
- 1 Brake chopper used in Run state
- 3 Used in Run and Stop state

When the frequency converter is decelerating the motor, the inertia of the motor and the load are fed into an external brake resistor. This enables the frequency converter to decelerate the load with a torque equal to that of acceleration (provided that the correct brake resistor has been selected). See separate Brake resistor installation manual.

2.4.3 DC-braking current

Defines the current injected into the motor during DC-braking.

2.4.4 DC-braking time at stop

Determines if braking is ON or OFF and the braking time of the DC-brake when the motor is stopping. The function of the DC-brake depends on the stop function, [parameter 2.1.12](#).

- 0 DC-brake is not used
- >0 DC-brake is in use and its function depends on the Stop function, ([par. 2.1.12](#)). The DC-braking time is determined with this parameter

Par. 2.1.12 = 0 (Stop function = Coasting):

After the stop command, the motor coasts to a stop without control from the frequency converter.

With the DC injection, the motor can be electrically stopped in the shortest possible time, without using an optional external braking resistor.

The braking time is scaled by the frequency when the DC-braking starts. If the frequency is greater than the nominal frequency of the motor, the set value of parameter 2.4.4 determines the braking time. When the frequency is $\leq 10\%$ of the nominal, the braking time is 10% of the set value of parameter 2.4.4.

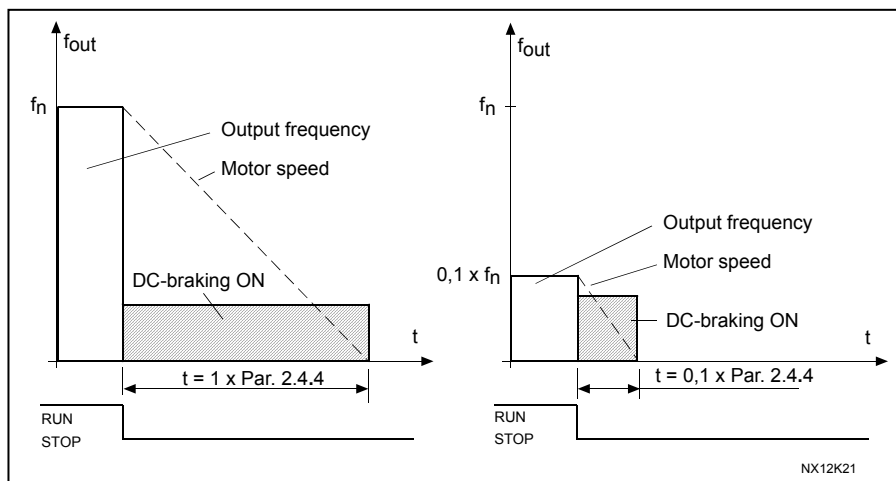

Figure 1- 13. DC-braking time when Stop mode = Coasting.

Par. 2.1.12 = 1 (Stop function = Ramp):

After the Stop command, the speed of the motor is reduced according to the set deceleration parameters, as fast as possible, to the speed defined with parameter 2.4.5, where the DC-braking starts.

The braking time is defined with parameter 2.4.4. If high inertia exists, it is recommended to use an external braking resistor for faster deceleration. See Figure 1- 14.

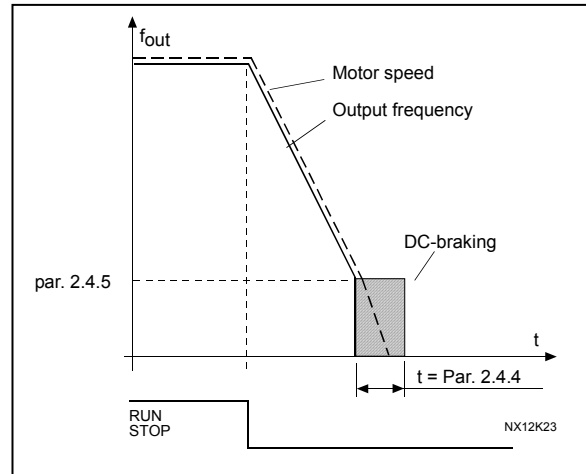

Figure 1- 14. DC-braking time when Stop mode = Ramp

2.4.5 DC-braking frequency in ramp stop

The output frequency at which the DC-braking is applied. See Figure 1- 14.

2.4.6 DC-braking time at start

DC-brake is activated when the start command is given. This parameter defines the time before the brake is released. After the brake is released, the output frequency increases according to the set start function by [parameter 2.1.11](#). See Figure 1- 15.

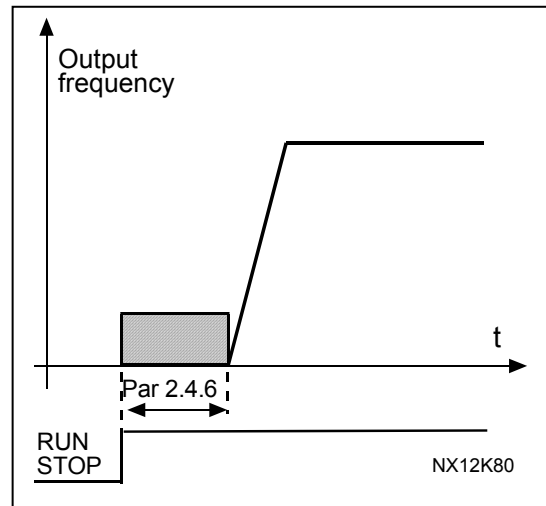

Figure 1- 15. DC braking time at start

2.4.7 *Flux brake*

Instead of DC braking, flux braking is a useful form of braking with motors $\leq 15\text{kW}$.

When braking is needed, the frequency is reduced and the flux in the motor is increased, which in turn increases the motor's capability to brake. Unlike DC braking, the motor speed remains controlled during braking

The flux braking can be set ON or OFF.

0 = Flux braking OFF

1 = Flux braking ON

Note: Flux braking converts the energy into heat at the motor, and should be used intermittently to avoid motor damage

2.4.8 *Flux braking current*

Defines the flux braking current value. It can be set between $0.3 \times I_H$ (approximately) and the [Current limit](#).

4.5 PROHIBIT FREQUENCIES

2.5.1 *Prohibit frequency area 1; Low limit*

2.5.2 *Prohibit frequency area 1; High limit*

In some systems it may be necessary to avoid certain frequencies because of mechanical resonance problems. With these parameters it is possible to set a limit for the "skip frequency" region. See Figure 1- 16.

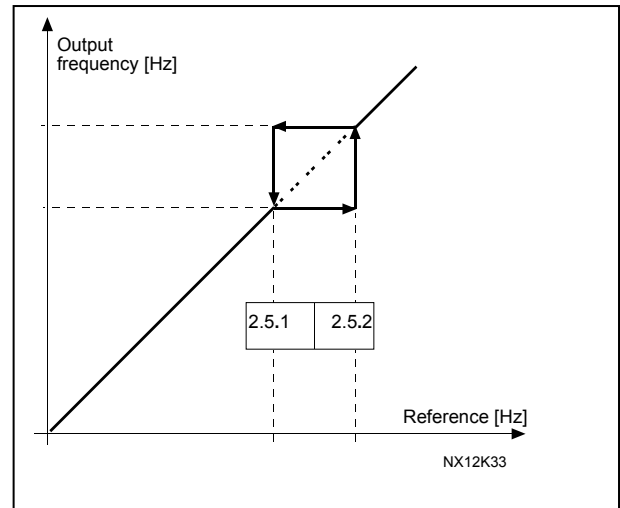

Figure 1- 16. Prohibit frequency area setting.

2.5.3 *Acceleration/deceleration ramp speed scaling ratio between prohibit frequency limits*

Defines the acceleration/deceleration time when the output frequency is between the selected prohibit frequency range limits (parameters 2.5.1 and 2.5.2). The ramping time (selected acceleration/ deceleration time 1 or 2) is multiplied with this factor. E.g. value 0.1 makes the acceleration time 10 times shorter than outside the prohibit frequency range limits.

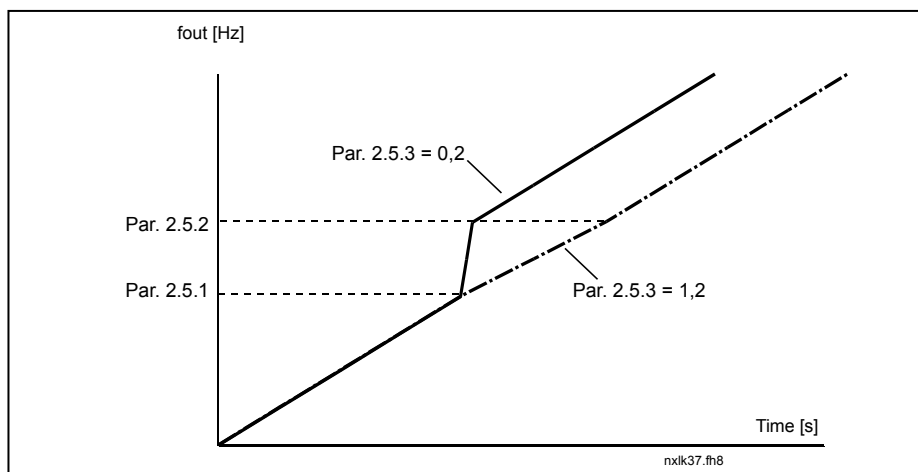

Figure 1- 17. Ramp time scaling between prohibit frequencies

4.6 MOTOR CONTROL

2.6.1 Motor control mode

- | | | |
|---|--------------------|---|
| 0 | Frequency control: | The I/O terminal and keypad references are frequency references and the frequency converter controls the output frequency (output frequency resolution = 0.01 Hz) |
| 1 | Speed control: | The I/O terminal and keypad references are speed references and the frequency converter controls the motor speed (accuracy $\pm 0,5\%$). |

2.6.2 U/f Optimisation

Automatic torque boost The voltage to the motor changes automatically which makes the motor produce sufficient torque to start and run at low frequencies. The voltage increase depends on the motor type and power. Automatic torque boost can be used in applications where starting torque due to starting friction is high, e.g. in conveyors.

EXAMPLE:

What changes are required to start with load from 0 Hz?

- ◆ First set the motor nominal values (Parameter group 2.1).

Option 1: Activate the Automatic torque boost.

Option 2: Programmable U/f curve

To get torque you need to set the zero point voltage and midpoint voltage/frequency (in parameter group 2.6) so that the motor takes enough current at low frequencies.

First set par. 2.6.3 to *Programmable U/f curve* (value **2**). Increase zero point voltage (par. 2.6.8) to get enough current at zero speed. Set then the midpoint voltage (par. 2.6.7) to $1.4142 \cdot P2.6.8$ and midpoint frequency (par. 2.6.6) to value $P2.6.8 / 100\% \cdot P2.1.7$.

NOTE: The programmable U/f curve is automatically tuned when **identification** is done.

NOTE! *In high torque – low speed applications – it is likely that the motor will overheat. If the motor has to run a prolonged time under these conditions, special attention must be paid to cooling the motor. Use external cooling for the motor if the temperature tends to rise too high.*

2.6.3 U/f ratio selection

Linear: The voltage of the motor changes linearly with the frequency in the constant flux area from 0 Hz to the field weakening point where the nominal voltage is supplied to the motor. Linear U/f ratio should be used in constant torque applications. See Figure 1- 18.

This default setting should be used if there is no special need for another setting.

Squared: The voltage of the motor changes following a squared curve form with the frequency in the area from 0 Hz to the field weakening point where the nominal voltage is also supplied to the motor. The motor runs under magnetised below the field weakening point and produces less torque and electromechanical noise. Squared U/f ratio can be used in applications where torque demand of the load is proportional to the square of the speed, e.g in centrifugal fans and pumps.

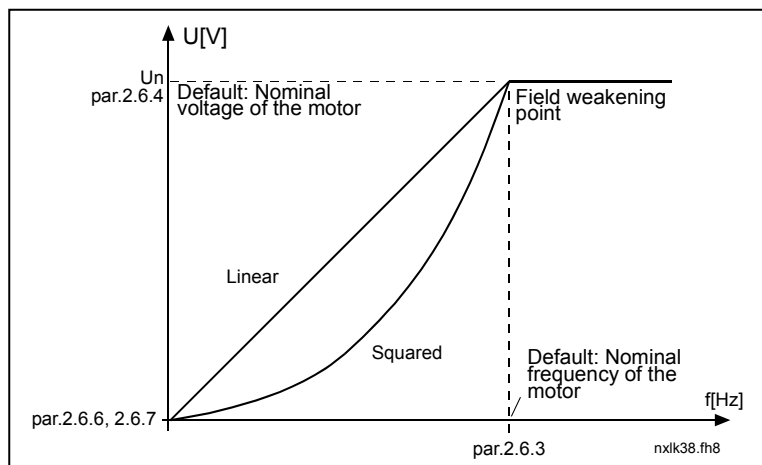

Figure 1- 18. Linear and squared change of motor voltage

Programmable U/f curve:

- 2 The U/f curve can be programmed with three different points. Programmable U/f curve can be used if the other settings do not satisfy the needs of the application.

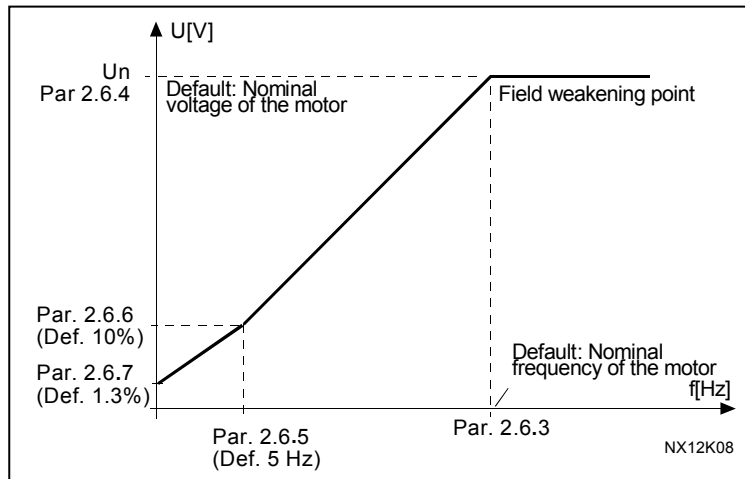

Figure 1- 19. Programmable U/f curve

Linear with flux optimisation:

- 3 The frequency converter starts to search for the minimum motor current and in order to save energy, lower the disturbance level and the noise. Can be used in applications with constant motor load, such as fans, pumps etc.

2.6.4 *Field weakening point*

The field weakening point is the output frequency at which the output voltage reaches the value set with par. 2.6.4.

2.6.5 *Voltage at field weakening point*

Above the frequency at the field weakening point, the output voltage remains at the value set with this parameter. Below the frequency at the field weakening point, the output voltage depends on the setting of the U/f curve parameters. See parameters 2.1.13, 2.6.2, 2.6.5 2.6.6 and 2.6.7 and Figure 1- 19.

When the parameters 2.1.6 and 2.1.7 (nominal voltage and nominal frequency of the motor) are set, the parameters 2.6.3 and 2.6.4 are automatically given the corresponding values. If you need different values for the field weakening point and the voltage, change these parameters **after** setting the parameters 2.1.6 and 2.1.7.

2.6.6 *U/f curve, middle point frequency*

If the programmable U/f curve has been selected with parameter 2.6.2 this parameter defines the middle point frequency of the curve. See Figure 1- 19.

2.6.7 *U/f curve, middle point voltage*

If the programmable U/f curve has been selected with the parameter 2.6.2 this parameter defines the middle point voltage of the curve. See Figure 1- 19.

2.6.8 *Output voltage at zero frequency*

This parameter defines the zero frequency voltage of the curve. See Figure 1- 19.

2.6.9 *Switching frequency*

Motor noise can be minimised using a high switching frequency. Increasing the switching frequency reduces the capacity of the frequency converter unit.

Switching frequency for Vacon NXL: 1...16 kHz

2.6.10 *Overvoltage controller*

2.6.11 *Undervoltage controller*

These parameters allow the under-/overvoltage controllers to be switched out of operation. This may be useful, for example, if the mains supply voltage varies more than -15% to +10% and the application will not tolerate this over-/undervoltage. This regulator controls the output frequency taking the supply fluctuations into account.

Note: Over-/undervoltage trips may occur when controllers are switched out of operation.

0 Controller switched off

1 Controller switched on

2.6.12 *Measured voltage drop*

The measured voltage drop at stator resistance between two phases with the nominal current of the motor.

2.6.13 *Identification*

0 No action

1 ID no run

NOTE: U/f optimisation (P2.6.2) has to be set to Auto Torque boost during identification if the Auto torque boost is to be used during operation. (The U/f curve is then tuned lower).

If P2.6.2 is switched on after identification it may cause the drive to go into current limit.

When ID no run is selected, the drive will perform an ID-run when it is started from selected control place. Drive has to be started within 20 seconds, otherwise identification is aborted.

The drive does not rotate the motor during ID no run. When ID run is ready the drive is stopped. Drive will start normally, when the next start command is given.

The ID run measures the Rs Voltage drop (P2.6.12) and tunes the U/f curve (P2.6.6-P2.6.8). P2.6.3 is changed to programmable automatically.

ID-run will result in a better torque at low speeds and improves the torque calculations and the automatic torque boost function. It will also result in a better slip compensation in speed control (more accurate RPM)

4.7 PROTECTIONS

2.7.1 *Response to 4mA reference fault*

- 0 = No response
- 1 = Warning
- 2 = Fault, stop mode after fault according to [parameter 2.1.12](#)
- 3 = Fault, stop mode after fault always by coasting

A warning or a fault action and message is generated if the 4...20 mA reference signal is used and the signal falls below 3.5 mA for 5 seconds or below 0.5 mA for 0.5 seconds. The information can also be programmed into relay outputs.

2.7.2 *Response to external fault*

- 0 = No response
- 1 = Warning
- 2 = Fault, stop mode after fault according to [parameter 2.1.12](#)
- 3 = Fault, stop mode after fault always by coasting

A warning or a fault action and message is generated from the external fault signal in the programmable digital inputs. The information can also be programmed into relay outputs.

2.7.3 *Response to undervoltage fault*

- 1 = Warning
- 2 = Fault, stop mode after fault according to [parameter 2.1.12](#)
- 3 = Fault, stop mode after fault always by coasting

For the undervoltage limits see Vacon NXL, User's Manual, Table 4-3.

Note: This protection can not be inactivated.

2.7.4 *Output phase supervision*

- 0 = No response
- 1 = Warning
- 2 = Fault, stop mode after fault according to [parameter 2.1.12](#)
- 3 = Fault, stop mode after fault always by coasting

Output phase supervision of the motor ensures that the motor phases have an approximately equal current.

2.7.5 *Earth fault protection*

- 0 = No response
- 1 = Warning
- 2 = Fault, stop mode after fault according to [parameter 2.1.12](#)
- 3 = Fault, stop mode after fault always by coasting

Earth fault protection ensures that the sum of the motor phase currents is zero. The overcurrent protection is always working and protects the frequency converter from earth faults with high currents.

Parameters 2.7.6—2.7.10, Motor thermal protection:

General

The motor thermal protection is to protect the motor from overheating. The Vacon drive is capable of supplying higher than nominal current to the motor. If the load requires this high current there is a risk that the motor will be thermally overloaded. This is the case especially at low frequencies. At low frequencies the cooling effect of the motor is reduced as well as its capacity. If the motor is equipped with an external fan the load reduction at low speeds is small.

The motor thermal protection is based on a calculated model and it uses the output current of the drive to determine the load on the motor.

The motor thermal protection can be adjusted with parameters. The thermal current I_T specifies the load current above which the motor is overloaded. This current limit is a function of the output frequency.



CAUTION! *The calculated model does not protect the motor if the airflow to the motor is reduced by blocked air intake grill.*

2.7.6 *Motor thermal protection*

- 0 = No response
- 1 = Warning
- 2 = Fault, stop mode after fault according to [parameter 2.1.12](#)
- 3 = Fault, stop mode after fault always by coasting

If tripping is selected the drive will stop and activate the fault stage.

Deactivating the protection, i.e. setting parameter to 0, will reset the thermal model of the motor to 0%.

2.7.7 Motor thermal protection: Motor ambient temperature factor

When the motor ambient temperature must be taken into consideration, it is recommended to set a value for this parameter. The value of the factor can be set between -100.0% and 100.0% where -100.0% corresponds to 0°C and 100.0% to the maximum running ambient temperature of the motor. Setting this parameter value to 0% assumes that the ambient temperature is the same as the temperature of the heatsink at power-on.

2.7.8 Motor thermal protection: Cooling factor at zero speed

The cooling power can be set between $0-150.0\%$ x cooling power at nominal frequency. See Figure 1- 20.

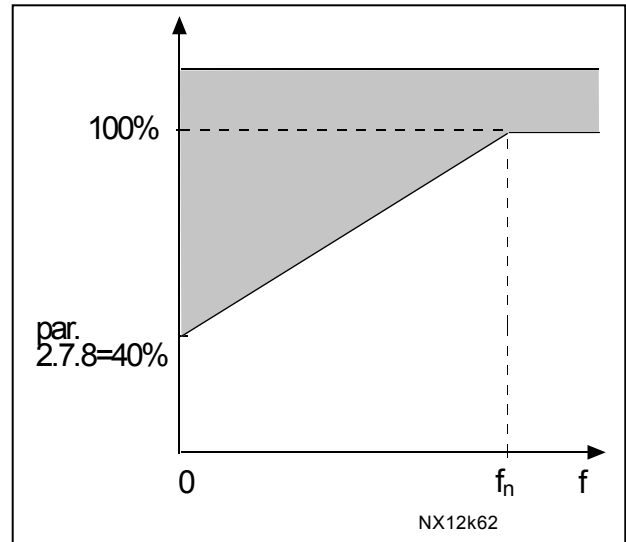

Figure 1- 20. Motor cooling power

2.7.9 Motor thermal protection: Time constant

This time can be set between 1 and 200 minutes.

This is the thermal time constant of the motor. The bigger the motor, the bigger the time constant. The time constant is the time within which the calculated thermal model has reached 63% of its final value.

The motor thermal time is specific to the motor design and it varies between different motor manufacturers.

If the motor's t_6 -time (t_6 is the time in seconds the motor can safely operate at six times the rated current) is known (given by the motor manufacturer) the time constant parameter can be set basing on it. As a rule of thumb, the motor thermal time constant in minutes equals to $2 \times t_6$. If the drive is in stop state the time constant is internally increased to three times the set parameter value. The cooling in the stop state is based on convection and the time constant is increased. See also Figure 1- 21.

Note: If the nominal speed (par. 2.1.8) or the nominal current (par. 2.1.9) of the motor are changed this parameter is automatically set to the default value (45).

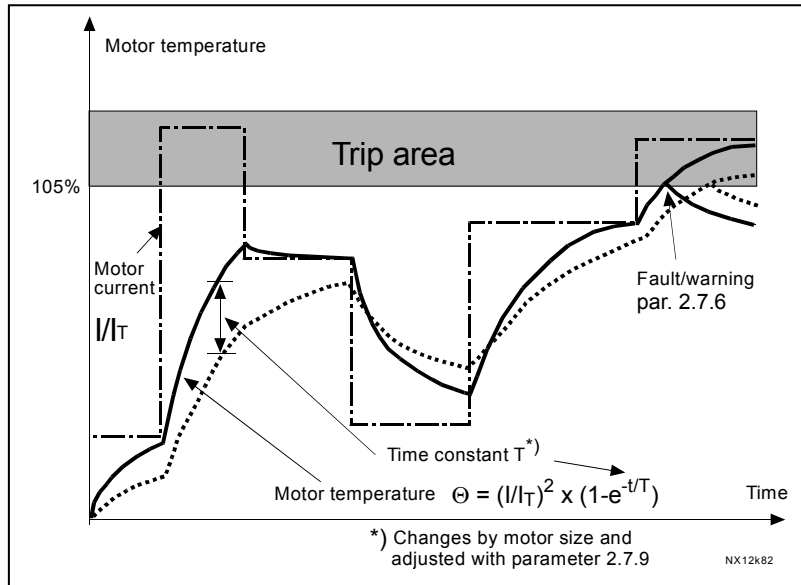

Figure 1- 21. Motor temperature calculation

2.7.10 Motor thermal protection: Motor duty cycle

Defines how much of the nominal motor load is applied.
The value can be set to 0%...100%.

Parameter 2.7.11, Stall protection:

General

The motor stall protection protects the motor from short time overload situations such as one caused by a stalled shaft. The reaction time of the stall protection can be set shorter than that of motor thermal protection. The stall state is defined with two parameters, 2.7.12 (Stall current) and 2.7.13 (Stall frequency). If the current is higher than the set limit and output frequency is lower than the set limit, the stall state is true. There is actually no real indication of the shaft rotation. Stall protection is a type of overcurrent protection.

2.7.11 Stall protection

- 0 = No response
- 1 = Warning
- 2 = Fault, stop mode after fault according to [parameter 2.1.12](#)
- 3 = Fault, stop mode after fault always by coasting

Setting the parameter to 0 will deactivate the protection and reset the stall time counter.

2.7.12 Stall current limit

The current can be set to $0.0 \dots I_{nMotor} * 2$. For a stall stage to occur, the current must have exceeded this limit. See Figure 1- 20. The software does not allow entering a greater value than $I_{nMotor} * 2$. If the [parameter 2.1.9](#) Nominal current of motor is changed, this parameter is automatically restored to the default value ($I_{nMotor} * 1.3$).

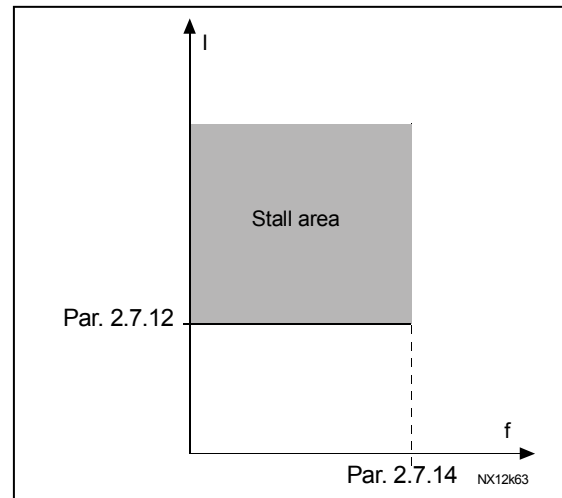

Figure 1- 22. Stall characteristics settings

2.7.13 Stall time

This time can be set between 1.0 and 120.0s.

This is the maximum time allowed for a stall event detection. The stall time is counted by an internal up/down counter. If the stall time counter value goes above this limit the protection will cause a trip (see Figure 1- 23)

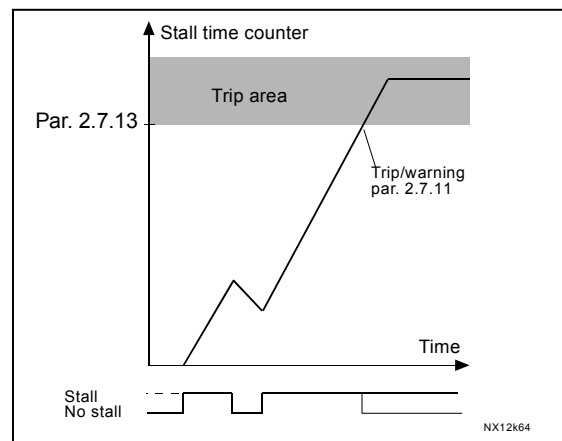

Figure 1- 23. Stall time count

2.7.14 Maximum stall frequency

The frequency can be set between $1 - f_{max}$ ([par. 2.1.2](#)).

For a stall event to occur, the output frequency must have remained below this limit.

Parameters 2.7.15—2.7.18, Underload protection:

General

The purpose of the motor underload protection is to ensure that there is load on the motor when the drive is running. If the motor loses its load there might be a problem in the process, e.g. a broken belt or a dry pump.

Motor underload protection can be adjusted by setting the underload curve with parameters 2.7.16 (Field weakening area load) and 2.7.17 (Zero frequency load), see below. The underload curve is a squared curve set between the zero frequency and the field weakening point. The protection is not active below 5 Hz (the underload time counter is stopped).

The torque values for setting the underload curve are set in percentage which refers to the nominal torque of the motor. The motor's name plate data, the parameter Motor nominal current and the drive's nominal current I_L are used to find the scaling ratio for the internal torque value. If other than nominal motor is used with the drive, the accuracy of the torque calculation decreases.

2.7.15 Underload protection

0 = No response

1 = Warning

2 = Fault, stop mode after fault according to [parameter 2.1.12](#)

3 = Fault, stop mode after fault always by coasting

If tripping is set active the drive will stop and activate the fault stage.

Deactivating the protection by setting the parameter to 0 will reset the underload time counter.

2.7.16 Underload protection, field weakening area load

The torque limit can be set between 10.0—150.0 % x T_{nMotor} .

This parameter gives the value for the minimum torque allowed when the output frequency is above the field weakening point. See Figure 1- 24.

If you change the [parameter 2.1.9](#) (Motor nominal current) this parameter is automatically restored to the default value.

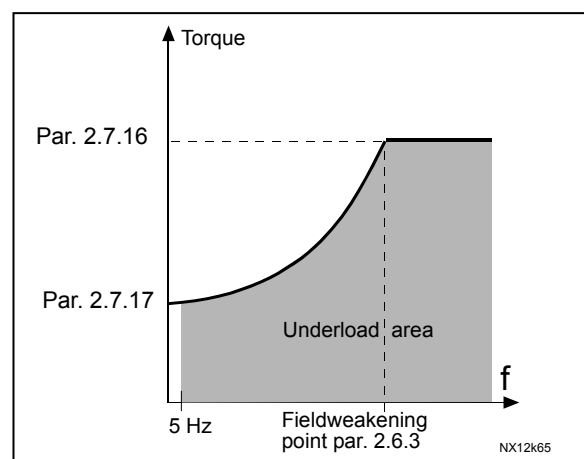

Figure 1- 24. Setting of minimum load

2.7.17 Underload protection, zero frequency load

The torque limit can be set between 5.0—150.0 % x T_{nMotor} .

This parameter gives value for the minimum torque allowed with zero frequency. See Figure 1- 24.

If you change the value of [parameter 2.1.9](#) (Motor nominal current) this parameter is automatically restored to the default value.

2.7.18 Underload time

This time can be set between 2.0 and 600.0 s.

This is the maximum time allowed for an underload state to exist. An internal up/down counter counts the accumulated underload time. If the underload counter value goes above this limit the protection will cause a trip according to [parameter 2.7.15](#). If the drive is stopped the underload counter is reset to zero. See Figure 1- 25.

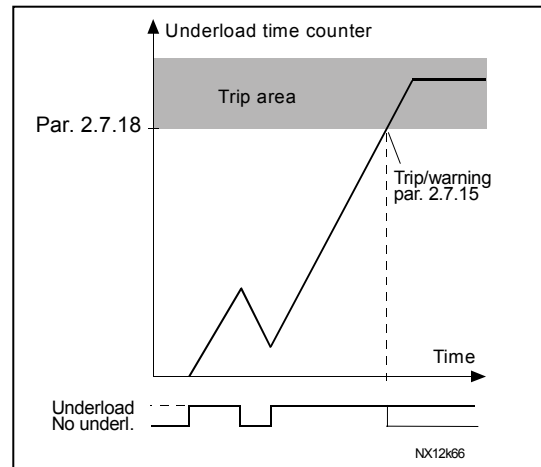

Figure 1- 25. Underload time counter function

2.7.19 Response to thermistor fault

0 = No response

1 = Warning

2 = Fault, stop mode after fault according to [parameter 2.1.12](#)

3 = Fault, stop mode after fault always by coasting

Setting the parameter to 0 will deactivate the protection.

2.7.20 Response to fieldbus fault

Set here the response mode for the fieldbus fault if a fieldbus board is used. For more information, see the respective Fieldbus Board Manual.

0 = No response

1 = Warning

2 = Fault, stop mode after fault according to [parameter 2.1.12](#)

3 = Fault, stop mode after fault always by coasting

4 = Warning, preset speed [parameter 2.7.22](#)

2.7.21 *Response to slot fault*

Set here the response mode for a board slot fault due to missing or broken board.

0 = No response

1 = Warning

2 = Fault, stop mode after fault according to [parameter 2.1.12](#)

3 = Fault, stop mode after fault always by coasting

4 = Warning, preset speed [parameter 2.7.22](#)

2.7.22 *Fieldbus fault frequency*

Frequency used as reference by parameter [2.7.20](#) and [2.7.21](#)

.

4.8 AUTO RESTART PARAMETERS

The automatic restart function is active if the value of par. 2.8.1 = 1. There are always three restart trials

2.8.1 Automatic restart

0 = Disabled

1 = Enabled (three automatic restarts)

2.8.2 Automatic restart: Wait time

Defines the time before the frequency converter tries to automatically restart the motor after the fault has disappeared.

2.8.3 Automatic restart: Trial time

The Automatic restart function restarts the frequency converter when the faults have disappeared and the waiting time has elapsed.

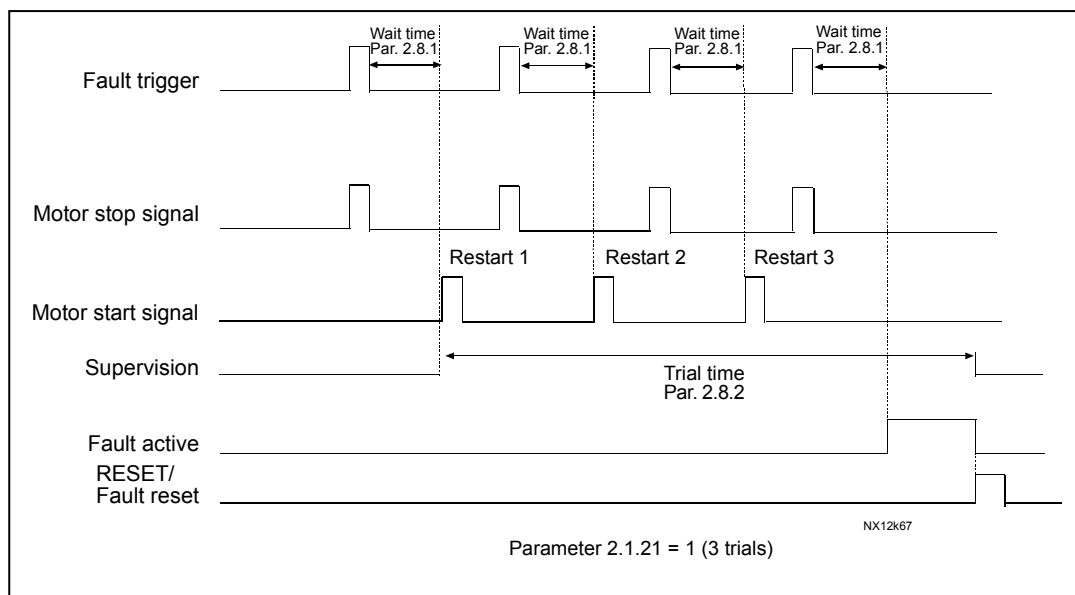

Figure 1- 26. Automatic restart.

The time count starts from the first autorestart. If the number of faults occurring during the trial time exceeds three, the fault state becomes active. Otherwise the fault is cleared after the trial time has elapsed and the next fault starts the trial time count again.

If a single fault remains during the trial time, a fault state is true.

2.8.4 *Automatic restart, start function*

The Start function for Automatic restart is selected with this parameter. The parameter defines the start mode:

- 0 = Start with ramp
- 1 = Flying start
- 2 = Start according to [par. 2.1.11](#)

4.9 SPEED REFERENCE PARAMETERS

- 2.9.1 Preset speed 0*
- 2.9.2 Preset speed 1*
- 2.9.3 Preset speed 2*
- 2.9.4 Preset speed 3*
- 2.9.5 Preset speed 4*
- 2.9.6 Preset speed 5*
- 2.9.7 Preset speed 6*
- 2.9.8 Preset speed 7*

Preset speeds by digital inputs are available independently of control place and have always the maximum priority in the reference chain.

Bit 2 (P2.2.9)	Bit 1 (P2.2.8)	Bit 0 (P2.2.7)	Reference selected
0	0	0	Preset speed 0 (P2.9.1)
0	0	1	Preset speed 1 (P2.9.2)
0	1	0	Preset speed 2(P2.9.3)
0	1	1	Preset speed 3(P2.9.4)
1	0	0	Preset speed 4(P2.9.5)
1	0	1	Preset speed 5(P2.9.6)
1	1	0	Preset speed 6(P2.9.7)
1	1	1	Preset speed 7(P2.9.8)

Table 1- 19. Preset speeds

4.10 MECHANICAL BRAKE PARAMETERS

2.10.1 *Current limit: brake open*

The mechanical brake is allowed to open when motor current exceeds the limit defined with this parameter.

2.10.2 *Frequency limit: brake open*

The mechanical brake is allowed to open when output frequency exceeds the limit defined with this parameter.

2.10.3 *Brake open delay*

This parameter sets the delay time for opening the mechanical brake after the limits defined with parameters 2.10.1 and 2.10.2 have been reached.

2.10.4 *Frequency limit: brake close*

The mechanical brake closes when output frequency reaches the limit defined with this parameter during a ramp stop.

2.10.5 *Brake close delay*

This parameter sets the delay time for closing the mechanical brake after the limit defined with parameter 2.10.4 has been reached.

4.11 FIELDBUS CONTROL PARAMETERS

2.11.1 *Fieldbus reference minimum scaling*

2.11.2 *Fieldbus reference maximum scaling*

Use these two parameters to scale the fieldbus reference signal.

Setting value limits: $0 \leq \text{par. P2.11.1} \leq \text{P2.11.2} \leq \text{P2.1.1}$. If par. 2.11.2 = 0, custom scaling is not used and the min and max frequencies are used for fieldbus reference scaling.

2.11.3 – 2.11.6 *Fieldbus data out selections 1 to 4*

With these parameters you can select the output data to fieldbus process data

1	Output frequency		
2	Motor speed		
3	Motor current		
4	Motor torque		
5	Motor power		
6	Motor voltage		
7	Fault code		
8	Frequency reference		
9	Unit temperature		
10	Motor temperature		
11	AI1		
12	AI2		
13	Input status word (see bit description below)	14	Output status word (see bit description below)
B0	DIN1	B0	R01
B1	DIN2	B1	A01 (When used as D02)
B2	DIN3	B2	Exp. board slot E, R01
B3	DIN4 (AI1 used as DIN4)	B3	Exp. board slot E, R02
B4	DIN5 (AI2 used as DIN5)	B4	Exp. board slot E, D01/R03
B5	DIE1 (Exp. board slot E, DIN1)	B5	Exp. board slot D, R01
B6	DIE2 (Exp. board slot E, DIN2)	B6	Exp. board slot D, R02
B7	DIE3 (Exp. board slot E, DIN3)	B7	Exp. board slot D, R03
B8	DIE2_1 (Exp. board slot D, DIN1)	B8	Exp. board slot D, R04
B9	DIE2_2 (Exp. board slot D, DIN2)	B9	Exp. board slot D, R05
B10	DIE2_3 (Exp. board slot D, DIN3)	B10	Exp. board slot D, R06
B11	DIE2_4 (Exp. board slot D, DIN4)		
B12	DIE2_5 (Exp. board slot D, DIN5)		
B13	DIE2_6 (Exp. board slot D, DIN6)		

Table 1- 20. Fieldbus data out selections

4.12 KEYPAD CONTROL PARAMETERS

3.1 *Control place*

The active control place can be changed with this parameter. For more information, see Vacon NXL User's Manual, Chapter 7.4.3.

3.2 *Keypad reference*

The frequency reference can be adjusted from the keypad with this parameter. For more information, see Vacon NXL User's Manual, Chapter 7.4.3.2.

3.3 *Keypad direction*

- 0 Forward: The rotation of the motor is forward, when the keypad is the active control place.
- 1 Reverse: The rotation of the motor is reversed, when the keypad is the active control place.

For more information, see Vacon NXL User's Manual, Chapter 7.4.3.3.

3.4 *Stop button activated*

If you wish to make the Stop button a "hotspot" which always stops the drive regardless of the selected control place, give this parameter the value 1 (default). See Vacon NXL User's Manual, Chapter 7.4.3.

See also parameter 3.1.

head office and
production:
Vaasa
Vacon Plc
Runsorintie 7
65380 Vaasa
firstname.lastname@vacon.com
telephone: +358 (0)201 2121
fax: +358 (0)201 212 205

production:
Suzhou, China
Vacon Suzhou Drives Co. Ltd.
Building 11A
428# Xinglong Street, SIP
Suchun Industrial Square
Suzhou 215126
telephone: + 86 512 62836630
fax: + 86 512 62836618

production:
Chambersburg, USA
3181 Black Gap Road
Chambersburg, PA 17202

sales companies and representative offices:

finland
Helsinki
Vacon Plc
Äyritie 8
01510 Vantaa
telephone: +358 (0)201 212 600
fax: +358 (0)201 212 699

Tampere
Vacon Plc
Vehmälynnkatu 18
33580 Tampere
telephone: +358 (0)201 2121
fax: +358 (0)201 212 750

australia
Vacon Pacific
17, Corporate Ave.
Rowville, Victoria 3178
telephone: +61 (03) 92139300
fax: +61 (03) 92139310

austria
Vacon AT Antriebssysteme GmbH
Aumühlweg 21
2544 Leobersdorf
telephone: +43 2256 651 66
fax: +43 2256 651 66 66

belgium
Vacon Benelux NV/SA
Interleuvenlaan 62
3001 Heverlee (Leuven)
telephone: +32 (0)16 394 825
fax: +32 (0)16 394 827

china
Vacon Suzhou Drives Co. Ltd.
Beijing Office
A528, Grand Pacific Garden
Mansion
8A Guanhua Road
Beijing 100026
telephone: + 86 10 51280006
fax: +86 10 65813733

france
Vacon France
ZAC du Fresne
1 Rue Jacquard - BP72
91280 Saint Pierre du Perray CDIS
telephone: +33 (0)1 69 89 60 30
fax: +33 (0)1 69 89 60 40

germany
Vacon GmbH
Gladbecker Strasse 425
45329 Essen
telephone: +49 (0)201 806 700
fax: +49 (0)201 806 7099

india
Vacon India
Plot No 352
Kapaleeshwar Nagar
East Coast Road
Neelangarai
Chennai-600041
Tel. +91 44 244 900 24/25

italy
Vacon S.p.A.
Via F.lli Guerra, 35
42100 Reggio Emilia
telephone: +39 0522 276811
fax: +39 0522 276890

the netherlands
Vacon Benelux BV
Weide 40
4206 CJ Gorinchem
telephone: +31 (0)183 642 970
fax: +31 (0)183 642 971

norway
Vacon AS
Bentsrudveien 17
3080 Holmestrand
Norway
telephone: +47 330 96120
fax: +47 330 96130

ruSSia
ZAO "Vacon Drives"
Ul. Letchika Babushkina 1,
Stroenie 3.
129344 Moscow
Russian Federation
Phone: +7 (495) 363 1985
Fax: +7 (495) 363 19 86

ZAO Vacon Drives
2ya Sovetskaya 7, office 210A
191036 St. Petersburg
telephone: +7 (812) 332 1114
fax: +7 (812) 279 9053

spain
Vacon Drives Iberica S.A.
Miquel Servet, 2. P.I. Bufalvent
08243 Manresa
telephone: +34 93 877 45 06
fax: +34 93 877 00 09

sweden
Vacon AB
Anderstorpvägen 16
171 54 Solna
telephone: +46 (0)8 293 055
fax: +46 (0)8 290 755

thailand
Vacon South East Asia
335/32 5th-6th floor
Srinakarin Road, Prawet
Bangkok 10250
Tel. +66 (0)85 100 7090

united arab emirates
Vacon Middle East and Africa
Block A, Office 4A 226
P.O.Box 54763
Dubai Airport Free Zone
Dubai
Tel. +971 (0)4 204 5200
Fax: +971 (0)4 204 5203

united kingdom
Vacon Drives (UK) Ltd.
18, Maizefield
Hinckley Fields Industrial Estate
Hinckley
LE10 1YF Leicestershire
telephone: +44 (0)1455 611 515
fax: +44 (0)1455 611 517

united states
Vacon, Inc.
440, North Fifth Avenue
Chambersburg, PA 17201

Vacon, Inc.
521 Airport Road
Chattanooga, TN 37421