

Fact Sheet

ExtensionBox™ for VLT® OneGearDrive®

Increase the available torque in conveyor applications up to 1000 Nm with easy to install extension for the VLT® OneGearDrive®.



Long and broad conveyors, such as those used for buffering and accumulation tables, or unpressurized reunification in filling lines, often require a high torque. Although the VLT® OneGearDrive® already delivers high torque over a wide speed range, certain applications may demand more.

Easy to install

The ExtensionBox™ is an accessory that is designed to be easy to attach to any OneGearDrive, which then can be fitted to the conveyor frame with a torque arm. Power is transmitted to the conveyor via a special belt. As a result known disadvantages of a gear stage are avoided. Instead, owners now have an oil and maintenance free solution that extends the available torque of the permanent magnet motor driven OneGearDrive significantly.

Easy spare parts handling

The ExtensionBox™ offers an additional advantage in that the number of OneGearDrive variants in stock in the plant is not increased. This supports owners in keeping storage and maintenance costs low.

Broader application area

The VLT OneGearDrive is already an industry favorite as part of Danfoss VLT® FlexConcept®, which is widely used in the food and beverage industry to increase energy efficiency and reliability.

With the new extension box, the OneGearDrive extends the scope of FlexConcept to other high torque applications that now also can utilize energy-efficient and matched components.



Feature	Benefit
<ul style="list-style-type: none"> – High system efficiency incl. VLT® OneGearDrive® and VLT® frequency converter 	<ul style="list-style-type: none"> – Save money and energy – up to 40% energy compared to conventional systems
<ul style="list-style-type: none"> – Completely smooth enclosure leaves no crevics or dirt traps 	<ul style="list-style-type: none"> – Easy to clean – Save production
<ul style="list-style-type: none"> – Only one ratio extends the torque range of the OneGearDrive up to 1000 Nm 	<ul style="list-style-type: none"> – Up to 70% reduction in variants reduces spare part stock
<ul style="list-style-type: none"> – Gearbox without breather vents and oil free operation – Service port 	<ul style="list-style-type: none"> – Reduces maintenance costs lower-contamination risks
<ul style="list-style-type: none"> – 40 mm hollow shaft optional with 1.5" or high quality stainless steel (AISI 316 Ti) 	<ul style="list-style-type: none"> – Flexible adaption to customer standards – Enhanced corrosion resistance

Dimensions

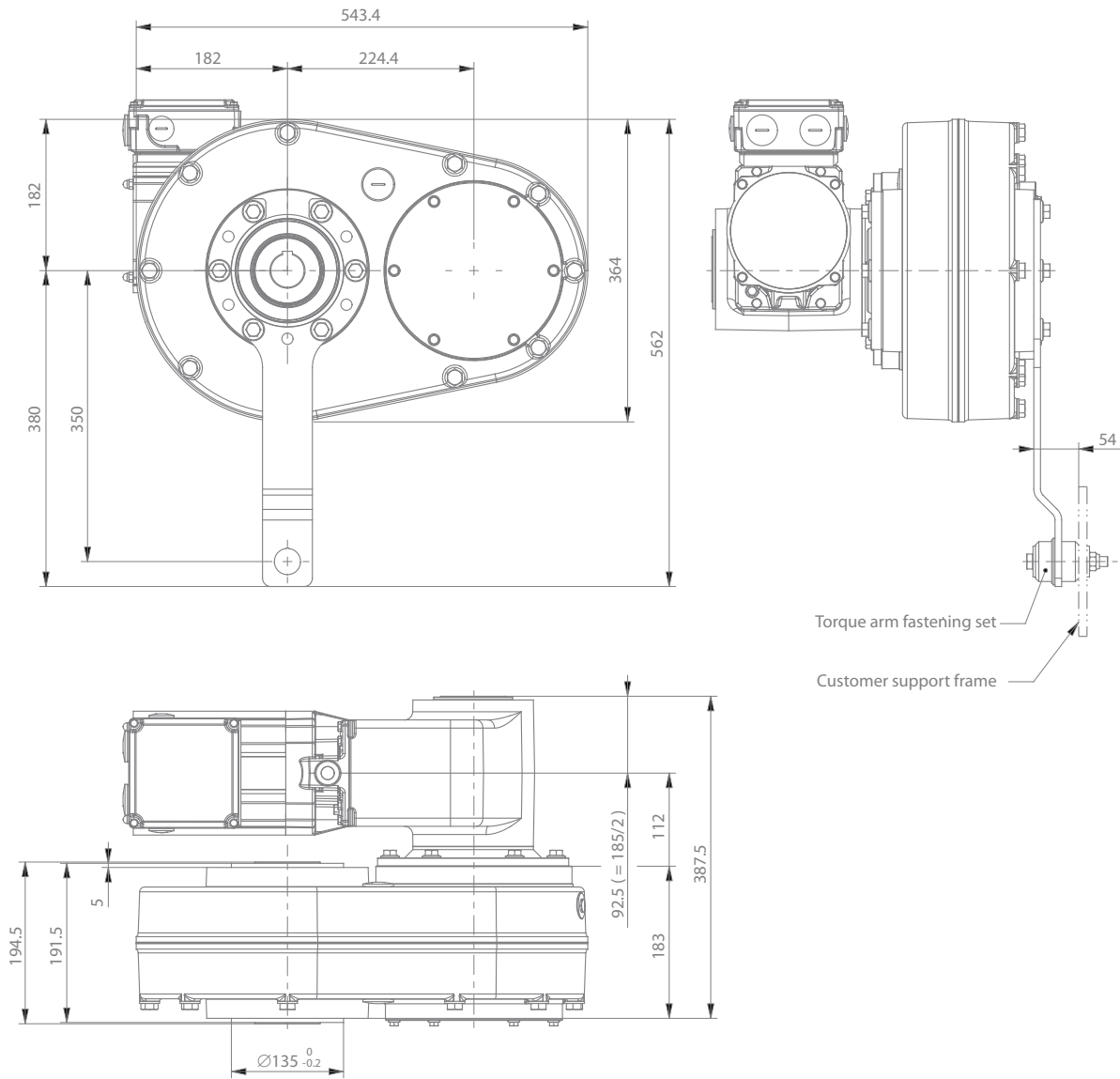

Danfoss VLT Drives, Ulsnaes 1, DK-6300 Graasten, Denmark, Tel. +45 74 88 22 22, Fax +45 74 65 25 80, www.vlt-drives.danfoss.com, E-mail: info@danfoss.com

Danfoss can accept no responsibility for possible errors in catalogues, brochures and other printed material. Danfoss reserves the right to alter its products without notice. This also applies to products already on order provided that such alterations can be made without subsequential changes being necessary in specifications already agreed. All trademarks in this material are property of the respective companies. Danfoss and the Danfoss logotype are trademarks of Danfoss A/S. All rights reserved.