

# INSTRUCTIONS VSH COMPRESSORS

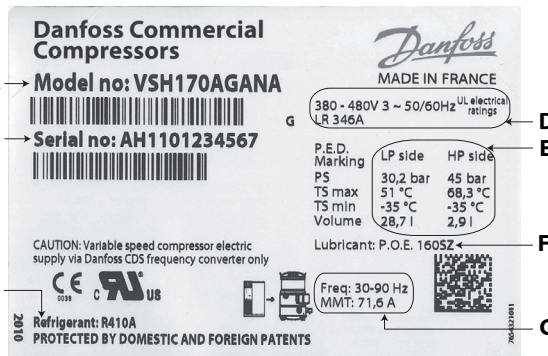

- A:** Model number
- B:** Serial number
- C:** Refrigerant
- D:** Supply voltage & Locked rotor current
- E:** Housing service pressure
- F:** Factory charged lubricant
- G:** Compressor frequency & Max Must trip current

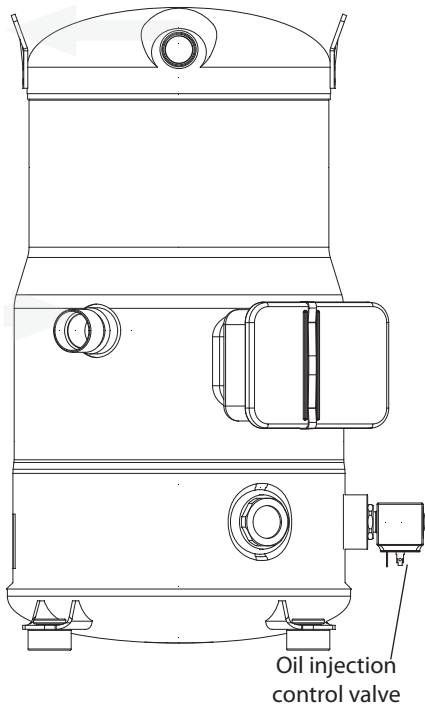
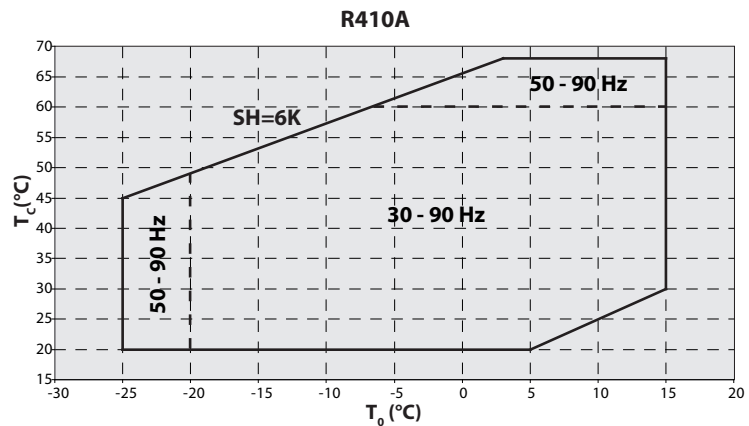

## Oil injection control assembly

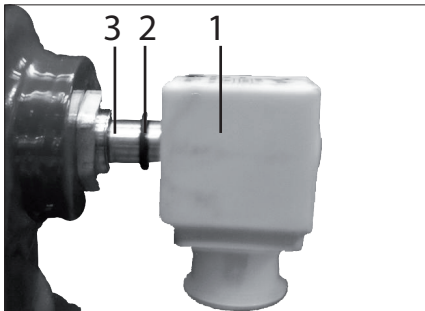

Put the clip-on coil (1) with the gasket (2) over the valve body (3) on the compressor

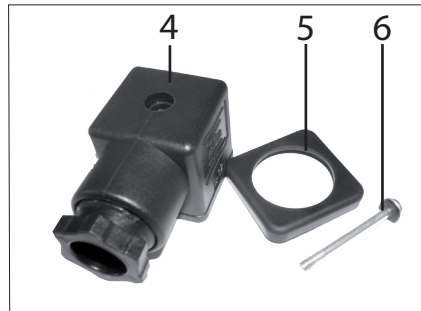

Attach the connector (4) to the coil using the delivered accessories (5) and (6).

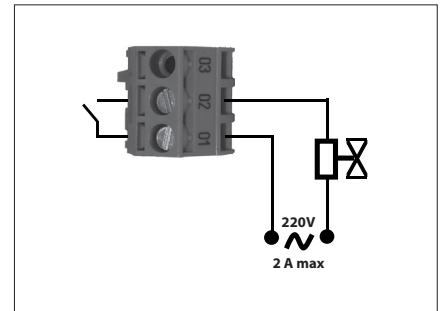

Wire the connector as indicated.

## Oil injection control dismantling

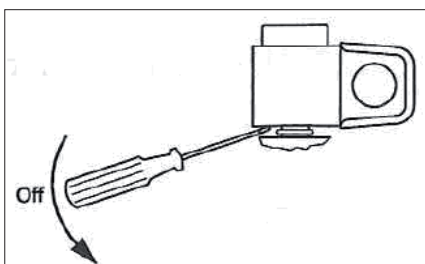

Remove the clip-on coil by using a screw driver.

⚠ The compressor must only be used for its designed purpose(s) and within its scope of application (refer to «operating limits»). Consult Application guidelines and datasheet available from <http://cc.danfoss.com>

⚠ Under all circumstances, the EN378 (or other applicable local safety regulation) requirements must be fulfilled.

The compressor is delivered under nitrogen gas pressure (between 0.3 and 0.7 bar) and hence cannot be connected as is; refer to the «assembly» section for further details.

The compressor must be handled with caution in the vertical position (maximum offset from the vertical : 15°)

### Basic connections

- Depending on the frequency converter version, the physical position of individual connectors may differ from below diagram.
- Always make sure that the compressor terminals T1, T2, T3 are connected to the frequency converter terminals 96, 97, 98 respectively.
- The compressor motor cable must be shielded

and the armoured part must be connected to ground on both cable ends; at the side of the compressor and at the side of the frequency converter.

- Use an EMC cable gland for cable installation and perfect grounding; The metallic terminal box of the compressor has a paint-free surface around

the connection hole for better conductivity.

- **A low pressure safety switch is mandatory to avoid compressor vacuum operation.**
- At start-up, verify that the compressor rotates in the right direction and pumps.

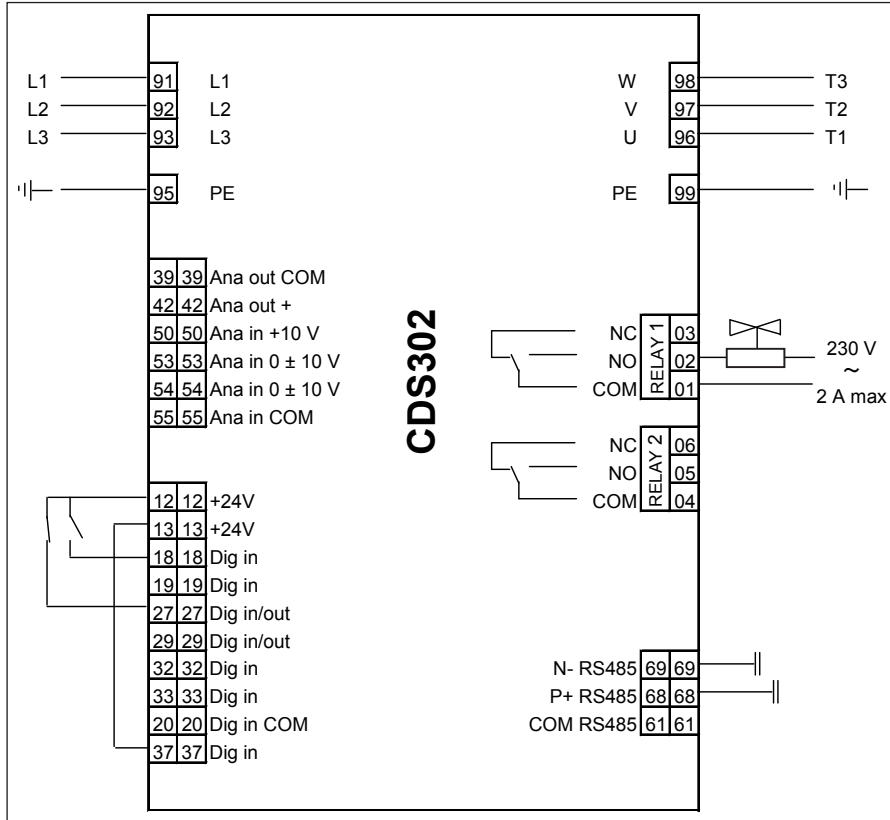

### Legends:

- Ana: Analogue
- Dig: Digital
- in: Input
- out: Output
- COM: Common
- NC: Normally-closed
- NO: Normally-open

		Open loop	Process loop
91, 92, 93:	3 Phase mains input	X	X
95:	Earth	X	X
39, 42	Analogue output	-	-
50:	Analogue input	-	-
53:	PLC+ (0 to 10 V)	X	-
54:	Sensor -	-	X
55:	PLC-	X	-
12:	HP/LP switch	X	X
12:	External On/Off (NO)	X	X
13:	Factory bridged to 37	X	X
13:	Sensor +	-	X
18:	External On/Off (NO)	X	X
19:	Digital input	-	-
27:	HP/LP switch (NC) / safety devices	X	X
29:	Digital input/output	-	-
32, 33	Digital input	-	-
20:	Digital input Common	-	-
37:	Factory bridged to 13	X	X
98:	To compressor terminal T3	X	X
97:	To compressor terminal T2	X	X
96:	To compressor terminal T1	X	X
99:	To compressor earth connection	X	X
02, 01:	Relay 1 to oil solenoid valve	X	X
06, 05, 04:	Relay 2	-	-
69, 68:	RS485 Bus	-	-
61:	RS485 Bus Common	-	-

- Optional connection
- X : Mandatory connection

The CDS302 frequency converter is factory pre-set with parameters for the *open loop* control principle. The *process loop* control principle can be selected by changing parameters in the «Quick menu».

### Open loop:

- 0 - 10 V control
- Frequency converter in slave mode

### Process loop:

- 4 - 20 mA control
- Frequency converter under own PID controller

## Instructions

### 1 - Introduction

These instructions pertain to the VSH Variable Speed scroll compressors used for A/C systems. They provide necessary information regarding safety and proper usage of this product.

### 2 - Handling and storage

- Handle the compressor with care. Use the dedicated handles in the packaging. Use the compressor lifting lug and use appropriate and safe lifting equipment.
- Store and transport the compressor in an upright position.
- Store the compressor between -35°C and 55°C.
- Don't expose the compressor and the packaging to rain or corrosive atmosphere.

### 3 - Safety measures before assembly

⚠ Never use the compressor in a flammable atmosphere.

- The compressor ambient temperature may not exceed 50°C during off-cycle.
- Mount the compressor on a horizontal flat surface with less than 3° slope.
- The compressor can only be supplied by a frequency converter. Make sure that the frequency converter is the dedicated one for the compressor (power size and voltage: input & output). Parameter 1.13 of the frequency converter lists the possible combinations of compressors, frequency converters and refrigerants.
- When installing a VSH, use equipment specifically reserved for HFC refrigerants which was never used for CFC refrigerants.
- Use clean and dehydrated refrigeration-grade copper tubes and silver alloy brazing material.
- Use clean and dehydrated system components.
- The piping connected to the compressor must be flexible in 3 dimensions to dampen vibrations.
- Make sure the installation is equipped with high-pressure safety components (e.g. pressure switch, pressure relief valve) to prevent against the bursting of pressure-containing components.

### 4 - Assembly

- Slowly release the nitrogen holding charge through the schrader port.
- Connect the compressor to the system as soon as possible to avoid oil contamination from ambient moisture.
- Avoid material entering into the system while cutting tubes. Never drill holes where burrs cannot be removed.
- Braze with great care using state-of-the-art technique and vent piping with nitrogen gas flow.
- Connect the required safety and control devices. When the schrader port is used for this, remove the internal valve.

### 5 - Leak detection

⚠ Never pressurize the circuit with oxygen or dry air. This could cause fire or explosion.

- Do not use dye for leak detection.
- Perform a leak detection test on the complete system.
- The low side test pressure must not exceed 30 bar.
- When a leak is discovered, repair the leak and repeat the leak detection.

### 6 - Vacuum dehydration

- Never use the compressor to evacuate the system.
- Connect a vacuum pump to both the LP & HP sides.
- Evacuate the system to a pressure of 500 µm Hg (0.67 mbar) absolute.
- Do not use a megohmmeter nor apply power to the compressor while it is under vacuum as this may cause internal damage.

### 7 - Electrical connections

- Switch off and isolate the main power supply. See previous page for wiring details.
- The compressor is protected against excess current by the frequency converter. Follow local regulations regarding power line protection. The compressor must be connected to ground.
- All electrical components must be selected as per local standards and compressor requirements.
- Please refer to drawings for typical wiring connections and examine the specific wiring diagram located in the frequency converter package. For further details, refer to the application guidelines.
- Follow very closely the installation instruction for the frequency converter:
  - **Mounting:** The base frame of the frequency converter must be very well fixed to the support to ensure a very good continuity between the ground potential of all electrical panels and electrical boxes of the system.
  - **Wiring:** All control wires have to be of a screened design. The cable for electrical motor supply has to be of a shielded design as well. Correct earthing of the shield cover has to be done using the method shown on drawings, every time this one has to be earthed on each end of the cables. Distinct cable trays must be used for control and motor supply.
- The frequency converter ensures direct motor protection and the factory set parameters are such to protect the motor over all current malfunctions. An external overload is not necessary.
- Set the frequency converter parameters in accordance with Danfoss recommendations for the CDS302 frequency converter and VSH variable speed compressor.

### 8 - Filling the system

- Keep the compressor switched off.
- Fill the refrigerant in liquid phase into the outlet side of the condenser or liquid receiver. The charge must be as close as possible to the nominal system charge to avoid low pressure operation and excessive superheat.

Compressor	Refrigerant charge limit (kg)
VSH088	5.9
VSH117	7.9
VSH170	13.5

Above this limit; protect the compressor against liquid flood-back with a pump-down cycle not lower than 2.3 bar (g) or a suction line accumulator.

- Never leave the filling cylinder connected to the circuit to avoid overfilling.

### 9 - Verification before commissioning

⚠ Use safety devices such as safety pressure switch and mechanical relief valve in compliance with both generally and locally applicable regulations and safety standards. Ensure that they are operational and properly set.

⚠ Check that the settings of high-pressure switches and relief valves don't exceed the maximum service pressure of any system component.

- A low-pressure switch is mandatory to avoid vacuum operation. Minimum setting 1.5 bar (g).
- Verify that all electrical connections are properly fastened and in compliance with local regulations.
- A crankcase heater is not required. This function is integrated in the CDS302 which provides a calibrated DC current during off cycles to heat the electrical motor. The CDS302 must be energized at least 12 hours before initial start-up and after prolonged shutdown.
- After commissioning it is strongly recommended to keep the frequency converter always energized.

### 10 - Start-up

- All service valves must be in the open position.
- Balance the HP/LP pressure.
- Energize the compressor. It must start promptly.
- If the compressor doesn't start, verify that the compressor is hooked up to the frequency converter; check the power lead connections. If these verifications reveal no abnormality, check the motor windings with an ohmmeter.
- Check the frequency converter control panel: If any alarm is displayed check the wiring and in particular the polarity of the control cables. If an alarm is shown, refer to the frequency converter application manual. Verify in particular the combination of compressor, frequency converter and refrigerant.
- Check current draw and voltage levels on the mains. The values for the compressor electrical motor can be directly displayed on the frequency converter control panel.
- The optimum compressor suction superheat is around 6K. The maximum allowed superheat is 30K.

### 11 - Check with running compressor

- Check current draw and voltage.
- Check suction superheat to reduce risk of slugging.
- Observe the oil level at start and during operation to confirm that the oil level remains visible. Excess foaming in oil sight glass indicates refrigerant on the sump.
- Monitor the oil sight glass for 1 hour after system equilibrium to ensure proper oil return to the compressor. This oil check has to be done over the speed range to guarantee:
  - a good oil return at low speed with minimum gas velocity.
  - a good oil management at high speed with maximum oil carry over.
- Respect the operating limits.
- Check all tubes for abnormal vibration. Movements in excess of 1.5 mm require corrective measures such as tube brackets.
- When needed, additional refrigerant in the liquid phase may be added in the low-pressure side as far as possible from the compressor. The compressor must be operating during this process.
- Do not overcharge the system.
- Never release refrigerant to the atmosphere.
- Before leaving the installation site, carry out a general installation inspection regarding cleanliness, noise and leak detection.
- Record type and amount of refrigerant charge as well as operating conditions as a reference for future inspections.
- **Compressor failure to build up pressure:** Check all bypass valves in the system to ensure that none of these has been opened. Also check that all solenoid valves are in their proper position.
- **Abnormal running noise:** Ensure the absence of any liquid flood-back to the compressor by means of measuring the return gas superheat and compressor sump temperature. The sump should be at least 6K above the saturated suction temperature under steady-state operating conditions.
- **The high-pressure switch trips out:** Check condenser operations (condenser cleanliness, fan operation, water flow and water pressure valve, water filter, etc.). If all these are OK, the problem may be due to either refrigerant overcharging or the presence of a non-condensable (e.g. air, moisture) in the circuit.
- **The low-pressure switch trips out:** Check evaporator operations (coil cleanliness, fan operations, water flow, water filter, etc.), liquid refrigerant flow and pressure drops (solenoid valve, filter dryer, expansion valve, etc.), refrigerant charge.
- **Low refrigerant charge:** The correct refrigerant charge is given by the liquid sight glass indication, the condenser delta T in relation to the refrigerant pressure tables (pressure-temperature), the superheat and the sub-cooling, etc. (if additional

## Instructions

charge is deemed necessary, refer to section 8).

- **Compressor short cycling:** The number of cycles shall never exceed 12 starts per hour.

### 12 - Maintenance

⚠ Internal pressure and surface temperature are dangerous and may cause permanent injury. Maintenance operators and installers require appropriate skills and tools. Tubing and compressor upper shell temperature may exceed 100°C and can cause severe burns.

⚠ Ensure that periodic service inspections to ensure system reliability and as required by local regulations are performed.

To prevent system related compressor problems, following periodic maintenance is recommended:

- Verify that safety devices are operational and properly set.
- Ensure that the system is leak tight.
- Check the compressor current draw.
- Confirm that the system is operating in a way consistent with previous maintenance records and ambient conditions.
- Check that all electrical connections are still adequately fastened.
- Keep the compressor clean and verify the absence of rust and oxidation on the compressor shell, tubes and electrical connections.
- Check the internal temperature of the frequency converter on its display and the cooling air flow.
- Faults are logged in the frequency converter memory and can be displayed. This can help to evaluate and improve parameters of the frequency converter or of the system itself.

### 13 - Warranty

Always transmit the model number and serial number with any claim filed regarding this product.

Use the fault memory of the frequency converter to recover the fault descriptions before initializing the system and even before shutting off the power.

The product warranty may be void in following cases:

- Absence of nameplate.
- External modifications; in particular, drilling, welding, broken feet and shock marks.
- Compressor opened or returned unsealed.
- Rust, water or leak detection dye inside the compressor.
- Use of a refrigerant or lubricant not approved by Danfoss.
- Any deviation from recommended instructions pertaining to installation, application or maintenance.
- Use in mobile applications.
- Use in explosive atmospheric environment.
- No model number or serial number transmitted with the warranty claim.

### 14 - Disposal

Danfoss recommends that compressors, frequency converters and compressor oil should be recycled by a suitable company.

