

Data Sheet

Solenoid valves
Type **EVU**

Normally Closed (NC)

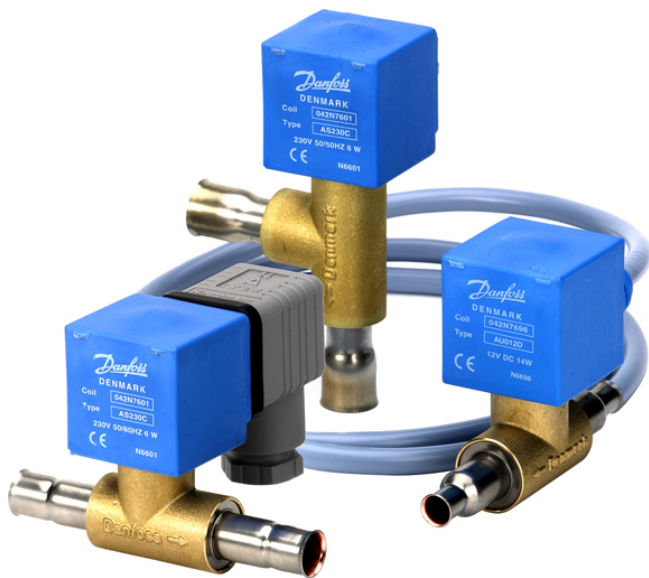

EVU solenoid valves are designed to fit into compact refrigeration systems. Available in direct and servo operated versions, they can be applied in liquid, suction, and hot gas lines with fluorinated refrigerants.

EVU solenoid valves can be used in many different refrigeration systems and are specially designed for:

- Commercial refrigeration systems
- Refrigeration appliances
- Liquid coolers
- Ice cube machines
- Mobile refrigeration systems
- Heat pump systems
- Air conditioning units

EVU valves are available in straightway or angleway design. All valves are semi hermetically sealed and are not serviceable. The standard coil is available with 3-core cable connection and DIN plug.

EVU valve bodies and coils are ordered separately.

Features

- Compact construction with small dimensions, low weight for both valve and coil.
- Semi-hermetic construction. Metallic sealing between armature tube and valve body. Bimetal connections to the brass housing benefits:
 - High strength of joints and high vibration resistance
 - Maximum external tightness within the whole temperature and pressure operation range
- Bimetal connections simple, fast soldering without the need of wet cloth or refrigeration pliers.
- Direct and servo operated mini piston compact solenoid valve.
- Universal application for
 - Liquid, Suction, and Hot gas applications
 - Reduced power consumption
- Simple and fast mounting of coil, Clip clip - ON / OFF.
- Small encapsulated coils with long life time under extreme conditions.
- Large MOPD range - up to 36 bar.

Functions

Figure 1: Direct operated

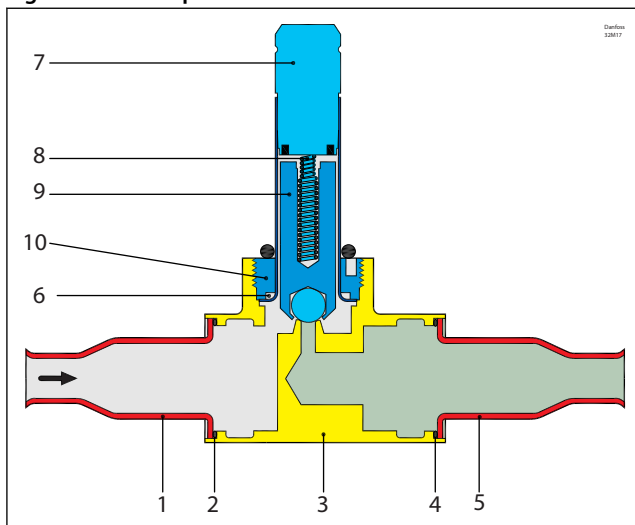
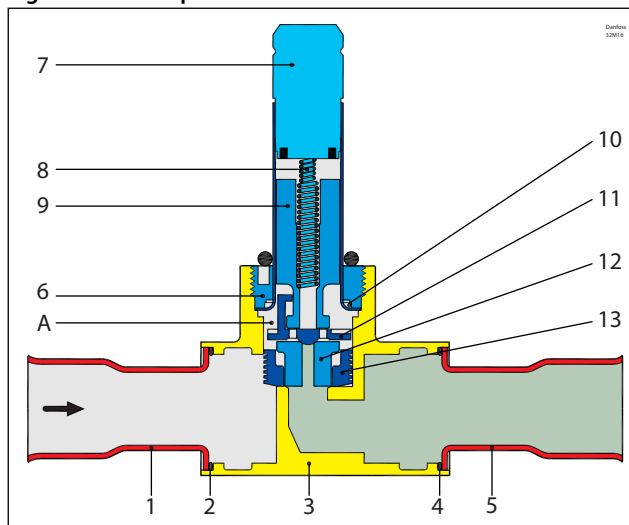

Figure 2: Servo operated



1,5	Solder connection	9	Armature
2,4	Solder ring	10	Support ring
3	Valve housing	11	Pilot plate (servo)
6	Union nut	12	Seat plate (servo)
7	Armature tube	13	Piston (servo)
8	Return spring	A	Servo chamber

Direct operated

EVU 1 is direct operated. The valve opens directly for full flow when the armature (9) moves up into the magnetic field of the coil.

This means that the valve can operate at 0 bar differential pressure. Thus, inlet pressure and spring force act to close the valve when the coil is currentless.

Servo operated

EVU 2 to 8 are servo operated piston solenoid valves. The servo piston principle results in a fast operating and compact valve that is able to open against a high differential pressure. The valve closes rather soft, because the pilot system does not fully close before the main orifice has closed. This minimizes liquid hammer.

When the coil is currentless, the main orifice, seat plate (12) and pilot orifice (on the pilot plate (11)) are closed. The pilot orifice and main orifice are held closed by the armature spring force and the differential pressure between inlet and outlet sides.

When current is applied to the coil, the armature (9) is drawn up into the magnetic field and thus lifts the pilot plate (11) and opens for the pilot orifice so that the de-energising of the servo chamber (A) starts and the pressure is relieved to the level of the outlet side. As the inlet pressure that acts on the bottom of the piston (13) now is higher than the pressure in the servo chamber (A), the piston is moved upwards and lifts both the pilot plate (11) and the seat plate (12). When the seat plate is lifted, the main orifice opens for full flow.

Therefore a minimum differential pressure of 0.02 bar is necessary to open the valve and keep it open.

When the current to the coil is switched off, the spring (8) forces the armature (9) down towards the pilot plate (11). The pressure in the servo chamber (A) increases and the piston will no longer be able to hold the seat plate (12) in lifted position, by which the main orifice closes. The armature (9) continues its downwards movement until the pilot orifice on the pilot plate (11) is fully closed.

Media

Refrigerants

R1233zd(E), R1234yf, R1234ze(E), R1270, R134a, R22/R407C, R23, R290, R32, R404A/R507A, R407A, R407F, R407H, R410A, R422B, R422D, R438A, R444B, R448A, R449A, R449B, R450A, R452A, R452B, R454A, R454B, R454C, R455A, R463A, R513A, R513B, R515A, R515B, R516A, R600, R600a, R744

For a complete list of approved refrigerants, visit store.danfoss.com and search for individual code numbers, where refrigerants are listed as part of technical data.

i NOTE:

Special note for R1233zd(E), R1234yf, R1234ze(E), R1270, R152A, R290, R32, R444B, R452B, R454A, R454B, R454C, R455A, R516A, R600 and R600a: This product is validated in accordance to ATEX, ISO 5149, IEC 60335-2-24, IEC 60335-2-40 and UL. Ignition risk is evaluated in accordance to ISO 5149 and IEC 60335.

The EVU can be applied on systems with the above specified refrigerants as working fluid.

For countries where safety standards are not an indispensable part of the safety system Danfoss recommends the installer gets a third party approval of any system containing flammable refrigerant.

i NOTE:

Please follow specific selection criteria stated in the datasheet for these particular refrigerants.

Temperature of medium

-40 – 105 °C max. 130 °C during defrosting

Ambient temperature

-40 – 50 °C

MOPD operating range

0.02 bar up to 36 bar

Humidity

0 – 100% R.H. (0-97% R.H. non-condensation condition if IP level is below IPX5).

Product specification

Design and materials

Table 1: Design and material specifications

No.	Description	Material	Alloys	Mat. no.	Standard		
					W.no.	DIN	EN
1, 5	Solder connection (Bi-metallic tube)	Stainless steel/Cu	-	-	-	-	-
2, 4	Solder ring	Silver	L-Ag 15P	CP102	-	1044	1044
3	Valve body	Brass	CuZn40Pb2	CW617N	2.0402	17672-1	12165
6	Union nut	Brass	CuZn39Pb2	CW612N	2.0380	17672-1	12164
7	Armature tube	Stainless steel	X6CrMoS17	-	1.4105	-	10088
8	Return spring	Spring wire stainless	X10CrNi18-8	-	1.4310	-	10088
9	Armature	Stainless steel	X4CrMoS18	-	1.410SIL	-	10088
10	Support ring	Teflon	PTFE	-	-	-	-
11	Pilot plate	Thermoplast	PEEK	-	-	-	-
12	Seat plate	Teflon	PTFE	-	-	-	-
13	Piston	Brass	CuZn39Pb2	CW612N	2.0380	17672-1	12164

Technical data

Table 2: Technical data

Type	Opening differential pressure with standard coil Δp [bar]			Temperature of medium [°C]	Max. working pressure [bar]	K_v -value ⁽¹⁾ [m ³ /h]
	Min.	Max. (=MOPD) liquid ⁽²⁾				
		6 W AC	14 W DC			
EVU 1	0.00	24 ⁽³⁾	19	-40 – 105	70	0.10
EVU 2	0.02	36	28	-40 – 105	70	0.20
EVU 3	0.02	36	28	-40 – 105	70	0.30
EVU 4	0.02	36	28	-40 – 105	70	0.50
EVU 5	0.02	36	28	-40 – 105	70	0.65
EVU 6	0.02	36	28	-40 – 105	70	0.75
EVU 8	0.02	36	25	-40 – 105	70	1.00

⁽¹⁾ The K_v value is the water flow in m³/h at a pressure drop across the valve of 1 bar, $\rho = 1000 \text{ kg/m}^3$.

⁽²⁾ MOPD for media in gas form is approx. 8 bar higher. MOPD is measured with highest media and ambient temperature and 15% below nominal voltage.

⁽³⁾ For coil 208-240 V, 60 Hz, MOPD is 17 bar.

Rated capacity [kW]

Table 3: Rated capacity [kW]

Type	Liquid				Suction vapour				Hot gas			
	R22/ R407C	R134a	R404A/ R507	R410A	R22/ R407C	R134a	R404A/ R507	R410A	R22/ R407C	R134a	R404A/ R507	R410A
EVU 1	2.01	1.85	1.40	2.01	0.23	0.16	0.20	0.29	0.93	0.73	0.75	1.40
EVU 2	4.02	2.96	2.24	3.22	0.45	0.33	0.40	0.58	1.85	1.47	1.51	2.79
EVU 3	6.03	5.55	4.20	6.03	0.68	0.49	0.60	0.87	2.78	2.20	2.26	4.19
EVU 4	10.05	9.25	7.00	10.05	1.30	0.82	1.00	1.45	4.63	3.67	3.77	6.99
EVU 5	13.07	12.03	9.10	13.07	1.46	1.06	1.30	1.89	6.01	4.77	4.90	9.81
EVU 6	14.39	13.96	10.21	14.79	1.54	1.21	1.45	2.09	7.02	5.18	5.52	8.25
EVU 8	20.10	18.50	14.00	20.10	2.25	1.63	2.00	2.90	9.25	7.33	7.53	13.97

Rated liquid and suction capacity is based on:

- evaporating temperature $t_e = -10 \text{ °C}$,
- liquid temperature ahead of the valve $t_l = 25 \text{ °C}$,
- pressure drop in valve $\Delta p = 0.15 \text{ bar}$

Rated hot gas capacity is based on:

Solenoid valves, Type EVU

- Condensing temperature $t_c = 40\text{ }^\circ\text{C}$,
- Pressure drop across valve $\Delta p = 0.8\text{ bar}$,
- Hot gas temperature $t_h = 65\text{ }^\circ\text{C}$
- Subcooling of refrigerant $\Delta t_{\text{sub}} = 4\text{ K}$

Valve selection based on capacity calculation

As for extended capacity calculations and valve selection based on capacities and refrigerants, please refer to Coolselector®2. Rated and extended capacities are calculated with the Coolselector®2 calculation engine to ARI standards with the ASEREP equations based on laboratory measurements of selected valves.

Dimensions [mm] and weight [kg]

Figure 3: EVU 1 – EVU 6, mounted with DIN coil connection

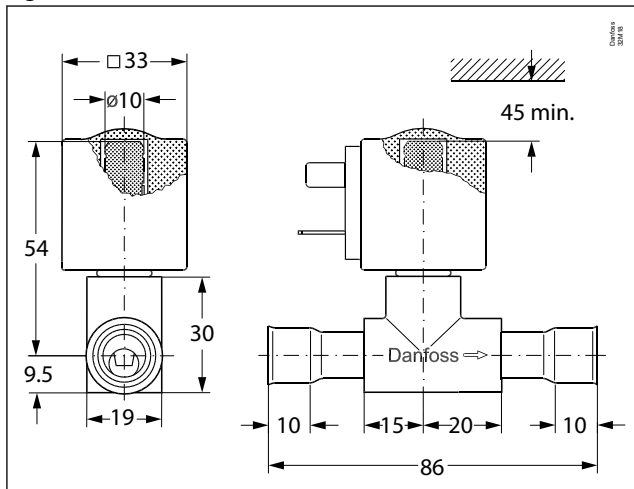

Figure 4: EVU 1 – EVU 6

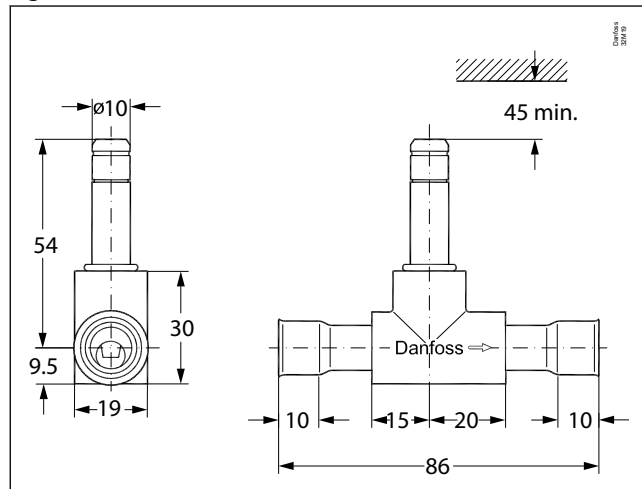

Figure 5: EVU 8

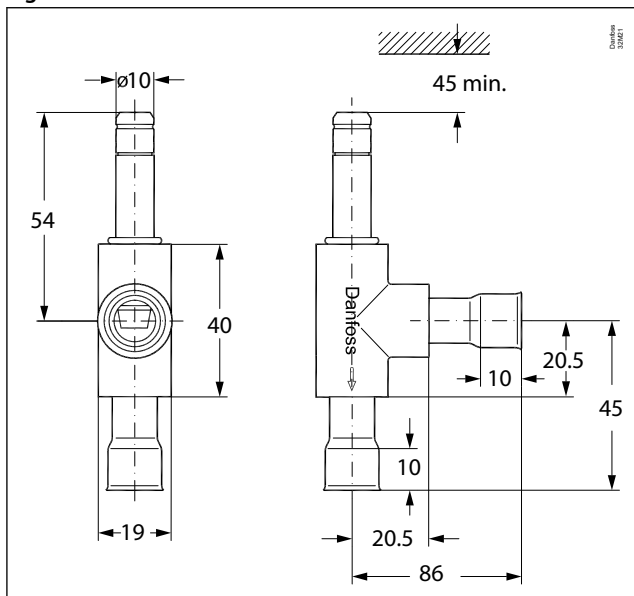

Table 4: Net weight [kg]

Product description	Net weight (approx.)
Coil 6 W	0.1
Coil with cable	0.15
Valve	0.1

Ordering

Packaging information

- **Single pack** 1 product in a box with installation guide.
- **Multi pack** box with x pieces single pack (can be split).
- **Industrial pack** x pieces in one box (cannot be split)

Ordering valve

Figure 6: EVU 1 – EVU 6 Figure 7: EVU 8

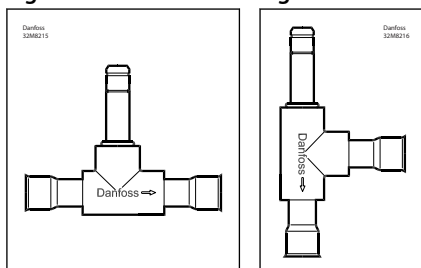

Table 5: Normally closed (NC)

Type	Connection		Industrial pack		Multi pack
	[in.]	[mm]	Code no.	Pcs	Code no.
EVU 1	1/4	–	032F7005	40	032F9524
	–	6	032F7004	40	–
EVU 2	–	6	032F5053	40	032F9529
	1/4	–	032F5024	40	032F9525
EVU 3	–	6	032F5025	40	032F9530
	3/8	–	032F5026	40	032F5111
	–	10	032F5027	40	–
EVU 4	–	10	032F5037	40	032F9531
	3/8	–	032F5105	40	032F9534
EVU 5	3/8	–	032F7000	40	032F9526
	–	10	032F7001	40	032F9532
	–	12	032F7003	40	–
EVU 6	3/8	–	032F5046	40	032F9527
	–	10	032F5047	40	–
	1/2	–	032F5049	40	032F9528
EVU 8	–	12	032F5048	40	032F9533
	–	12	032F8009	40	–

Ordering Coils

NOTE:

Special note for R1233zd(E), R1234yf, R1234ze(E), R1270, R152A, R290, R32, R444B, R452B, R454A, R454B, R454C, R455A, R516A, R600 and R600a: The EVU coil (IP65/67) is validated in accordance to ISO 5149, IEC 60335 (ref. IEC/EN 60079-15). Ignition risk is evaluated in accordance to ISO 5149 and IEC 60335 (ref. IEC/EN 60079-15).

Please make sure that there is no spark, arc on the spade connection during the application. If coils are below IPx5, they must be protected against ultraviolet, moisture and major impact, especially the connection of coils.

Always Install a fuse ahead of the coil: rated current: two times of rated current, time lag: medium, to avoid short circuit.

The coil used in an area of not more than pollution degree 2.

Follow the installation guide to mount the coil correctly, and apply o-ring for sealing to prevent moisture penetrating inside the coil.

Solenoid valves, Type EVU

IMPORTANT:

The EVU coil (IP65/67) can be applied on systems with the above specified refrigerants as the working fluid. For countries where safety standards are not an indispensable part of the safety system, Danfoss recommends the installer to get a third party approval of the system containing flammable refrigerant.

NOTE:

please follow specific selection criteria stated in the datasheet for these particular refrigerants.

NOTE:

The EVU coil (IP65/67) has NOT been verified ATEX or IECEx or IEC 60079 series zone 2 compliant. This product is only validated for systems in compliance with ISO5149, IEC 60335 (ref. IEC/EN 60079-15). It is the responsibility of the user to verify such compliance. Improper use can cause explosion, fire, leakage potentially causing death, personal injury, or damage to property.

Figure 8: DIN spade connection

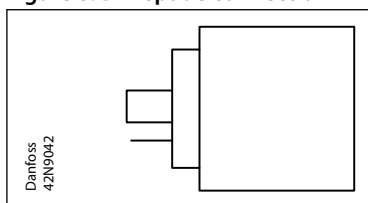

Table 6: Alternating current [AC] - with DIN plug - IP65

Type	Ambient Temp.	Supply voltage	Voltage variation	Frequency	Power consumption		Industrial pack		Multi pack
	[°C]				[V]	[Hz]	[W]	[VA]	Code no.
AS024CS	-40 – 50	24	-15% – 10%	50	9.5	18	-	-	042N7608
		24	-15% – 10%	60	7.0	14			
AS230CS	-40 – 50	230	-15% – 10%	50	8.0	16	-	-	042N7601
		208 – 240	-15% – 10%	60	7.0	14			
AS240CS	-40 – 50	240	-15% – 10%	50	6.5	13	-	-	042N7602
		240	-15% – 10%	60	5.0	10			

NOTE:

The three pins on the coil can be fitted with spade tabs, 6.3 mm wide (to DIN 46247). The two current carrying pins can also be fitted with spade tabs, 4.8 mm wide. Max. lead cross section: 1.5 mm². If DIN plug is used (DIN 43650) the leads must be connected in the socket. The socket is fitted with a Pg 11 screwed entry for 6 – 12 mm.

Figure 9: Cable connection

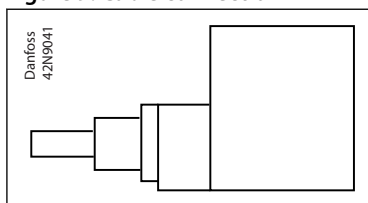

Table 7: Alternating current [AC] - with 1 m cable - IP67

Type	Ambient Temp.	Supply voltage	Voltage variation	Frequency	Power consumption		Industrial pack		Multi pack
	[°C]				[V]	[Hz]	[W]	[VA]	Code no.
AU115CS	-40 – 50	115	-15% – 10%	50	7.0	14	-	-	042N7662
		115	-15% – 10%	60	5.0	10			
AU230CS	-40 – 50	230	-15% – 10%	50	7.0	14	042N8651	20	042N7651
		230	-15% – 10%	60	5.0	10			
AU240CS	-40 – 50	240	-15% – 10%	50	6.5	13	042N8652	20	-
		240	-15% – 10%	60	5.0	10			

Solenoid valves, Type EVU

Figure 10: DIN spade connection (UL recognized)

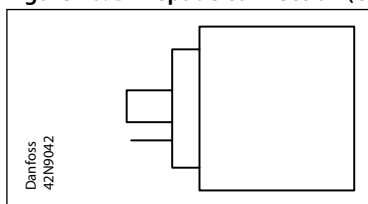

Table 8: Alternating current [AC] - DIN spade connection (UL recognized) IP00

Type	Ambient Temp.	Supply voltage	Voltage variation	Frequency	Power consumption		Industrial pack		Multi pack
	[°C]				[V]	[W]	[VA]	Code no.	Pcs.
AZ240CS	-40 – 50	230	-15% – 10%	50	8.0	16	042N8201	40	042N4201
		208 – 240			7.0	14			
AZ120CS	-40 – 50	115	-15% – 10%	50	8.5	16	042N8202	40	042N4202
		110 – 120			7.0	14			
AZ024CS	-40 – 50	24	-15% – 10%	50	9.5	18	042N8203	40	042N4203
		24			7.0	14			

Figure 11: Cable connection

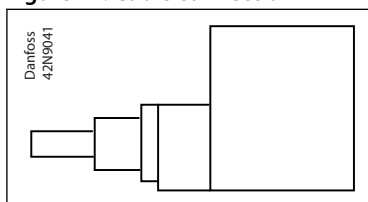

Table 9: Direct current [DC] - with 1 m cable IP67

Type	Ambient Temp.	Supply voltage	Voltage variation	Frequency	Power consumption		Industrial pack		Multi pack
	[°C]				[V]	[W]	[VA]	Code no.	Pcs.
AU012DS	-40 – 50	12	±10%	DC	12	–	042N8696	20	042N7696
AU024DS	-40 – 50	24	±10%	DC	14	–	042N8697	20	042N7697

Figure 12: DIN spade connection

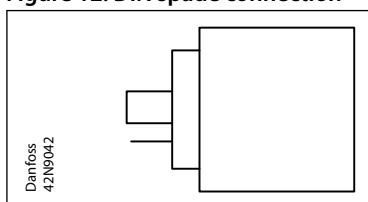

Table 10: Direct current [DC] - with DIN spade IP00

Type	Ambient Temp.	Supply voltage	Voltage variation	Frequency	Power consumption		Industrial pack		Multi pack
	[°C]				[V]	[W]	[VA]	Code no.	Pcs.
AS012DS	-40 – 60	12	±10%	DC	14	–	042N8686	40	–
AS024D	-40 – 50	24	±10%	DC	14	–	042N8687	40	042N7687

NOTE:

DC coils with 0.25 in. US spade can be supplied on request

Accessories

Table 11: Accessories

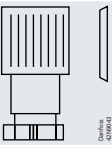
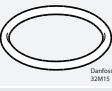
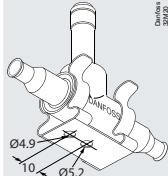
Part	Description	Code no.			
		Multi pack	Pcs.	Industrial pack	Pcs.
	DIN plug (EN175301-803 type A)	042N1256	-	-	-
	O-ring for sealing the coil. Industrial pack (50 pcs.) NB: Valve body supplied with O-ring	032F6115	-	-	-
	Bracket for fixing of valve.	-	-	032F8036	40

Certificates, declarations, and approvals

The list contains all certificates, declarations, and approvals for this product type. Individual code number may have some or all of these approvals, and certain local approvals may not appear on the list.

Some approvals may change over time. You can check the most current status at danfoss.com or contact your local Danfoss representative if you have any questions.

Table 12: Certificates, declarations, and approvals

Document name	Document type	Document topic	Approval authority
MH7648	Electrical - Safety Certificate		UL

Online support

Danfoss offers a wide range of support along with our products, including digital product information, software, mobile apps, and expert guidance. See the possibilities below.

The Danfoss Product Store



The Danfoss Product Store is your one-stop shop for everything product related—no matter where you are in the world or what area of the cooling industry you work in. Get quick access to essential information like product specs, code numbers, technical documentation, certifications, accessories, and more.

Start browsing at store.danfoss.com.

Find technical documentation



Find the technical documentation you need to get your project up and running. Get direct access to our official collection of data sheets, certificates and declarations, manuals and guides, 3D models and drawings, case stories, brochures, and much more.

Start searching now at www.danfoss.com/en/service-and-support/documentation.

Danfoss Learning



Danfoss Learning is a free online learning platform. It features courses and materials specifically designed to help engineers, installers, service technicians, and wholesalers better understand the products, applications, industry topics, and trends that will help you do your job better.

Create your Danfoss Learning account for free at www.danfoss.com/en/service-and-support/learning.

Get local information and support



Local Danfoss websites are the main sources for help and information about our company and products. Find product availability, get the latest regional news, or connect with a nearby expert—all in your own language.

Find your local Danfoss website here: www.danfoss.com/en/choose-region.

Coolselector®2 - find the best components for you HVAC/R system



Coolselector®2 makes it easy for engineers, consultants, and designers to find and order the best components for refrigeration and air conditioning systems. Run calculations based on your operating conditions and then choose the best setup for your system design.

Download Coolselector®2 for free at coolselector.danfoss.com.

Danfoss A/S

Climate Solutions • danfoss.com • +45 7488 2222

Any information, including, but not limited to information on selection of product, its application or use, product design, weight, dimensions, capacity or any other technical data in product manuals, catalogues descriptions, advertisements, etc. and whether made available in writing, orally, electronically, online or via download, shall be considered informative, and is only binding if and to the extent, explicit reference is made in a quotation or order confirmation. Danfoss cannot accept any responsibility for possible errors in catalogues, brochures, videos and other material. Danfoss reserves the right to alter its products without notice. This also applies to products ordered but not delivered provided that such alterations can be made without changes to form, fit or function of the product.

All trademarks in this material are property of Danfoss A/S or Danfoss group companies. Danfoss and the Danfoss logo are trademarks of Danfoss A/S. All rights reserved.