



MCE101C Load Controller

BLN-95-9005-2

Issued: April 2002

DESCRIPTION

The MCE101C Load Controller is used to limit the power output from systems in which prime-mover inputs to the work stage are loaded by power outputs from the work stage. By limiting the output, the Controller keeps the prime-mover input near setpoint.

In a typical application, the MCE101C supplies a dithered voltage to a proportional solenoid valve that regulates servo pressure on a manually-controlled servo positioned hydrostatic transmission used to modulate a trencher's ground speed. As heavy trenching loads, such as rocks or compacted earth, are encountered, the Load Controller quickly responds to engine droop. By automatically reducing the commanded ground speed, engine stoppage is avoided and engine wear (caused by running at non-optimal speed) is reduced.



The solenoid valve works in conjunction with the charge supply orifice in the manual displacement control to reduce servo pressure as engine speed reduces. The reduced servo pressure results in lower pump displacement and, therefore, slower ground speed. The servo positioned hydrostatic pumps must have sufficient spring centering moments to destroke the pump with reduced servo pressure. Heavy duty pumps with standard springs can be used in most applications.

FEATURES

- Short circuit and reverse polarity protected
- Rugged design resists shock, vibration, humidity and rain
- Instant load shedding avoids engine stall
- Versatile installation with either surface or panel mounting
- Remotely mounted controls allow operator to adapt to varied load conditions
- Available in both 12 and 24 volt models
- Requires no sophisticated tools to calibrate
- Adaptable to any heavy-equipment engine
- Forward/Reverse acting

ORDERING INFORMATION

SPECIFY

1. Model Number MCE101C1016, MCE101C1022. See Table A. for electrical and performance characteristics adaptable to customer requirements.

Table A.

DEVICE NUMBER	SUPPLY VOLTAGE (Vdc)	RATED OUTPUT VOLTAGE (Vdc)	RATED OUTPUT CURRENT (AMPS)	MINIMUM LOAD RESISTANCE (OHMS)	RPM ADJUST ON/OFF SWITCH	FREQUENCY RANGE (Hz)	PROPORTIONING BAND (%)	DITHER	MOUNTING	ACTING
MCE101C1016	11 - 15	10	1.18	8.5	REMOTE	300 - 1100	40	50 HZ 100 mAmp	SURFACE	REVERSE
MCE101C1022	22 - 30	20	0.67	30	REMOTE	1500 - 5000	40	50 HZ 100 mAmp	SURFACE	FORWARD

$$\text{MAXIMUM OUTPUT} = + \text{SUPPLY} - 3 \text{ Vdc.}$$

$$\text{SUPPLY CURRENT} = \text{LOAD CURRENT} + 0.1 \text{ AMP}$$

TECHNICAL DATA

Electrical

Variations in electrical specifications for devices are reflected in Table A. Controllers with specifications different from those in Table A. are available upon request. See Table A. in Ordering Information.

Environmental

OPERATING TEMPERATURE
-20° to 65° C (-4° to 149° F)

STORAGE TEMPERATURE
-30° to 65° C (-22° to 149° F)

HUMIDITY
After being placed in a controlled atmosphere of 95% humidity at 40° C for 10 days, the Controller will perform within specification limits.

RAIN
After being showered from all directions by a high pressure hose down, the Controller will perform within specification limits.

VIBRATION
Withstands a vibration test designed for mobile equipment controls consisting of two parts:

1. Cycling from 5 to 2000 Hz in each of the three axes.
2. Resonance dwell for one million cycles for each resonance point in each of the three axes.

Run from 1 to 8 g's. Acceleration level varies with frequency.

SHOCK
50 g for 11 milliseconds. Three shocks in both directions of the three mutually perpendicular axes for a total of 18 shocks.

DIMENSIONS
See Dimensions - MCE101C1016 and MCE101C1022.

Performance

CONTROL PARAMETERS (5)

AUTO/MANUAL SWITCH
AUTO: Controller ON
MANUAL: Controller OFF

RPM ADJUST CONTROL
Operator-adjusted in accordance with load conditions. The adjustment is a percentage of the RPM setpoint.

RPM SETPOINT
A 25-turn, infinite adjustment control.

FEEDBACK FREQUENCY INPUT RANGE
Controllers are shipped with fixed frequency ranges. Table A shows the full frequency span.

REVERSE POLARITY PROTECTION
50 Vdc maximum

SHORT CIRCUIT PROTECTION (Auto Only)
Indefinite. Models with supply current over 1 amp with voltages at high end of rating and at high ambient temperatures may have their performance degraded after several minutes of short circuit.

DIMENSIONS - MCE101C1016 and MCE101C1022

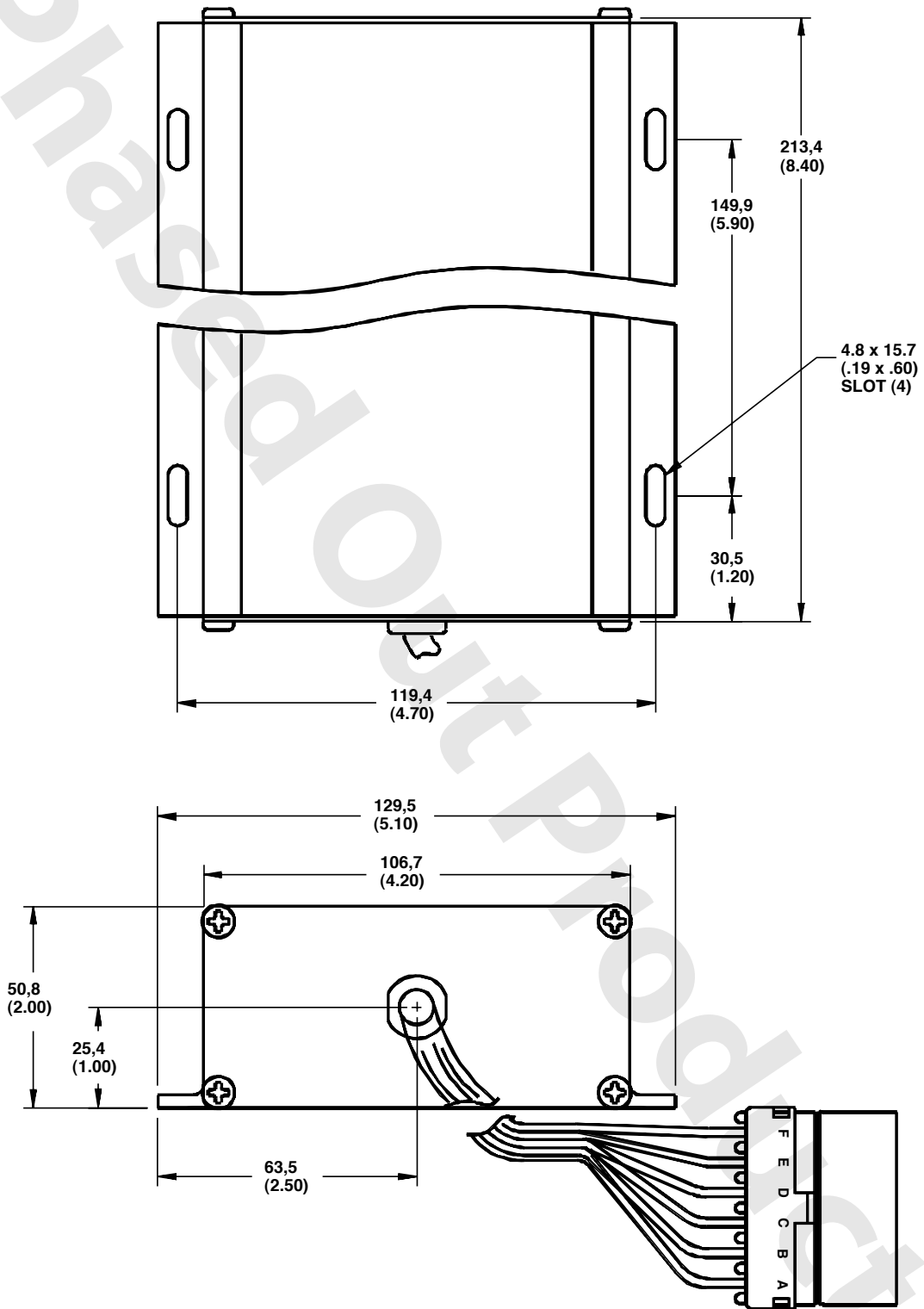

1383

Panel Mounting Dimensions of the MCE101C1016 and MCE101C1022 in Millimeters (Inches).

THEORY OF OPERATION

The MCE101A Load Controller is used to reduce the power requested from a system under conditions which would otherwise overstress the system. The work function being controlled may be the ground speed of a ditcher, chain velocity of a wood chipper or other applications in which engine speed must be kept near an optimum horsepower.

The work function is generally accomplished through the use of a hydrostatic transmission whose prime mover is the vehicle's engine. The engine is set at an RPM which maximizes its efficiency. When the hydrostatic transmission encounters resistance during its work cycle, it transmits the information back as a torque opposing the engine, which lugs the engine below the desired operating point. Either a pulse pick-up or the vehicle alternator relays engine speed, in the form of a frequency, to the Load Controller, where it undergoes a frequency-to-voltage conversion. The voltage is then compared against a reference voltage from the adjustable RPM setpoint potentiometer. If an engine governor is used, it performs the necessary corrective action within a given band around the setpoint. But when engine droop is great enough (i.e., input voltage crosses the setpoint), the output voltage from the Controller is increased. See Curves

Diagram 1 and Curves Diagram 2. This increases the signal to the proportional solenoid valve on the hydrostatic transmission, which in turn sheds servo pressure reducing pump swash angle, which sheds engine load. As commanded work is reduced, the opposing torque on the engine is proportionally diminished and engine speed rises towards setpoint. With heavy loads, engine speed will reach an equilibrium point somewhere on the RPM-output voltage curve. The effect is the same except that the operator has full control of hydrostatic transmission speed until engine droop crosses the RPM setpoint.

The response time from encountering the load to reducing the commanded power is approximately one half second. Once load is shed, the Controller automatically begins increasing output voltage. If the load encountered is instantaneous - for instance, if a rock is struck and removed immediately while trenching - the "ramp up" is five seconds. This "quick dump/slow recover" feature avoids unstable oscillations in the loop, giving the operator greater control of his machines. The Block Diagram shows a typical control loop used on a trencher or scraper auger system.

MCE101C1016 Curves - Diagram 1

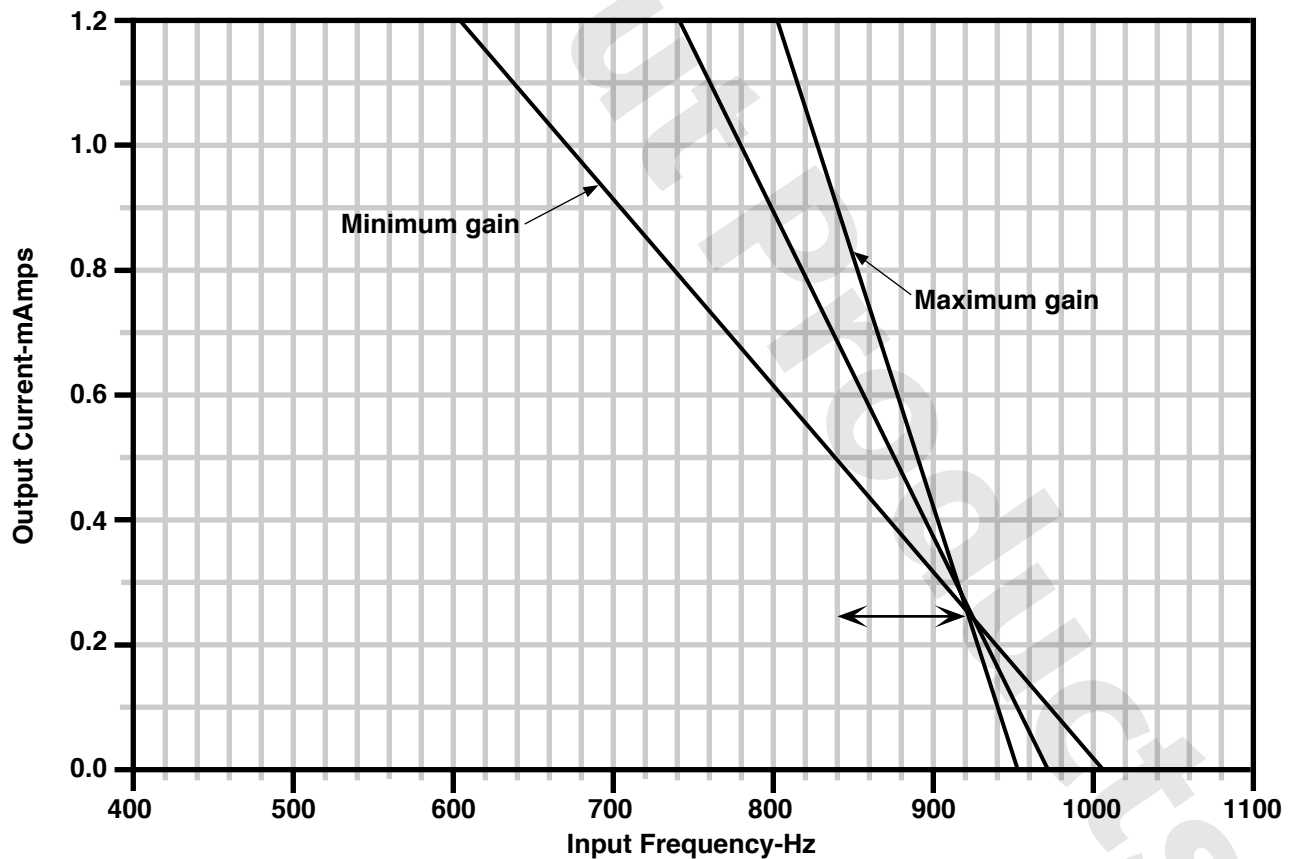

1384

MCE101C1016 Load Controller Curves Showing Output Voltage as a Function of Engine Droop. The Setpoint Illustrated is 920 Hz. Setpoint and Sensitivity are Adjustable.

MCE101C1022 Curves - Diagram 2

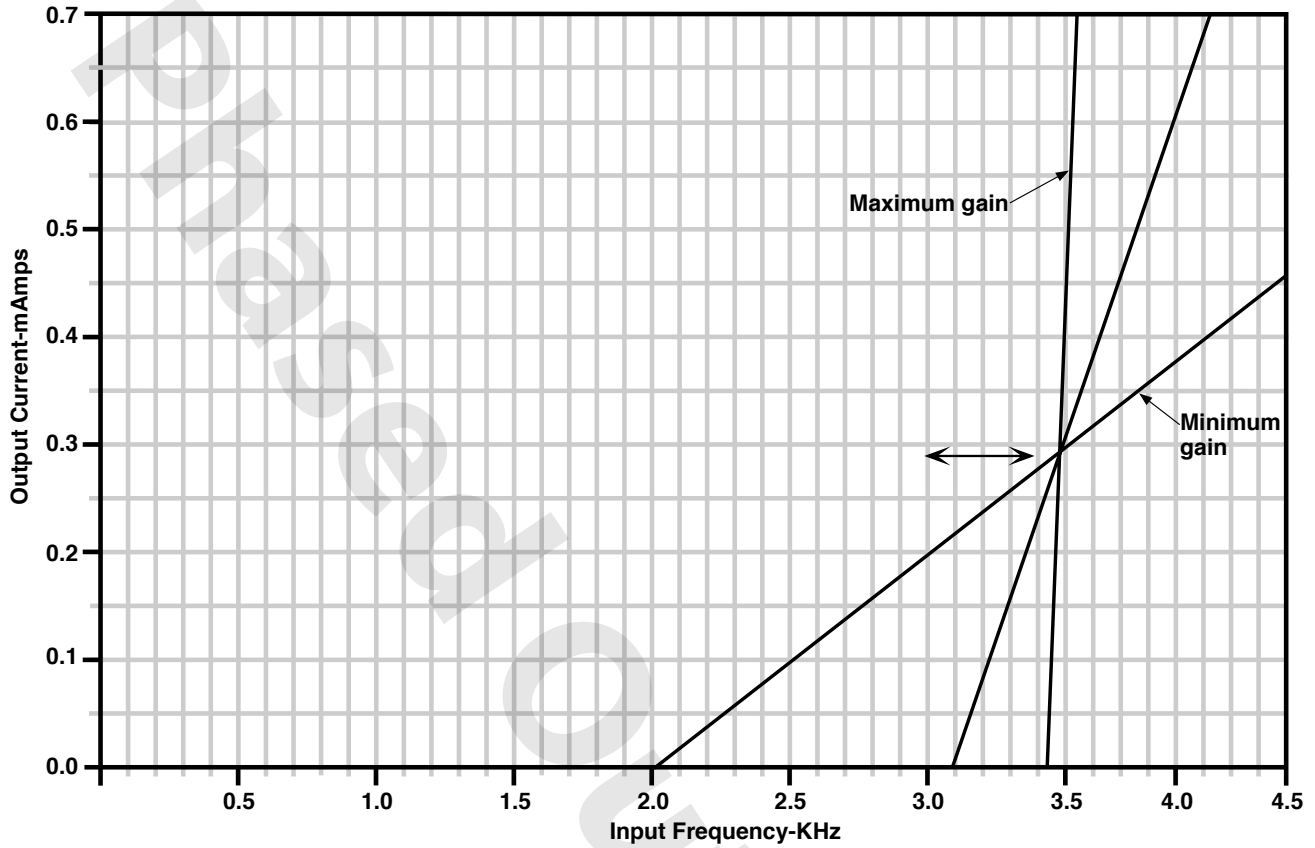

1847

**MCE101C1022 Load Controller Curves Showing Output Voltage as a Function of Engine Speed.
The Setpoint Illustrated is 3470 Hz. Setpoint and Sensitivity are Adjustable**

WIRING

Wiring connections are made with Packard Connectors. Engine input to the Controller must be an AC voltage frequency. Attach to a single-phase tap when using the alternator.

MOUNTING

The MCE101C Controllers listed in Table A are surface-mount models only.

See Dimensions-MCE101C1016 and MCE101C1022.

ADJUSTMENTS

There are two control parameters that must be adjusted: AUTO-ON/OFF switch and RPM ADJUST setpoint. See MCE101C Curves Diagram 1 and Curves Diagram 2.

1. **AUTO ON/OFF SWITCH**
The Load Controller will be ON during normal machine use but is overridden in OFF position. Work to be done while machine is in idle must be done with switch OFF.
2. **RPM ADJUST SETPOINT**
The RPM setpoint is varied through a 1-turn potentiometer. The potentiometer is mounted on the Controller's front panel, or remotely mounted.

To adjust the RPM setpoint, turn controller switch to AUTO ON mode, and set the RPM ADJUST setpoint to minimum. Set vehicle throttle to high idle. Start operating ditch trenching chain at actual desired depth and speed. Manually stroke hydrostatic pump to full forward with gear box in digging mode. Controller will maintain a slow ground speed which will not load engine significantly. Slowly increase RPM. Adjust to increase ground speed and decrease engine RPM to point of optimum productivity or minimum engine wear.

BLOCK DIAGRAM

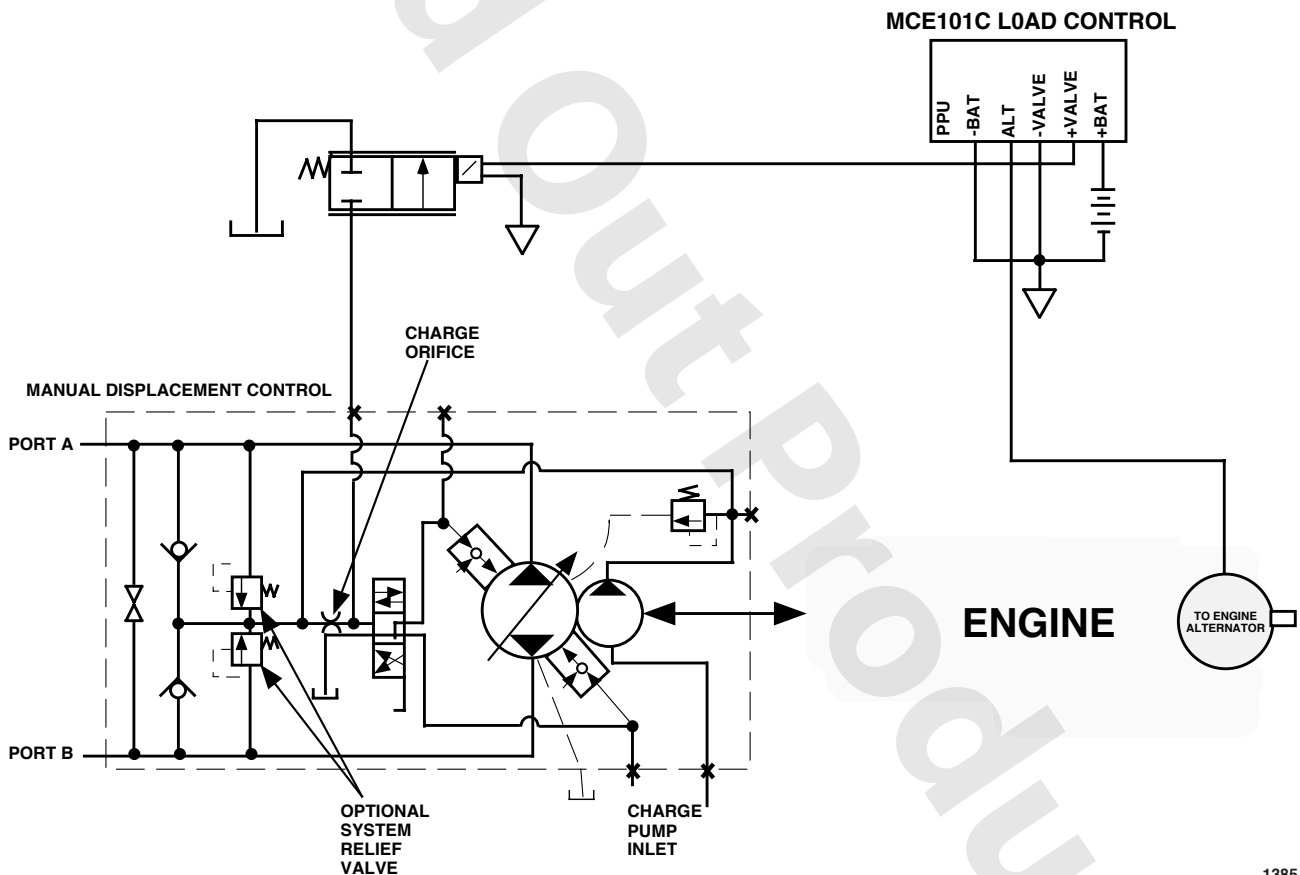

1385

MCE101C Used in a Closed-loop Load Control System.

CONNECTION DIAGRAM 1

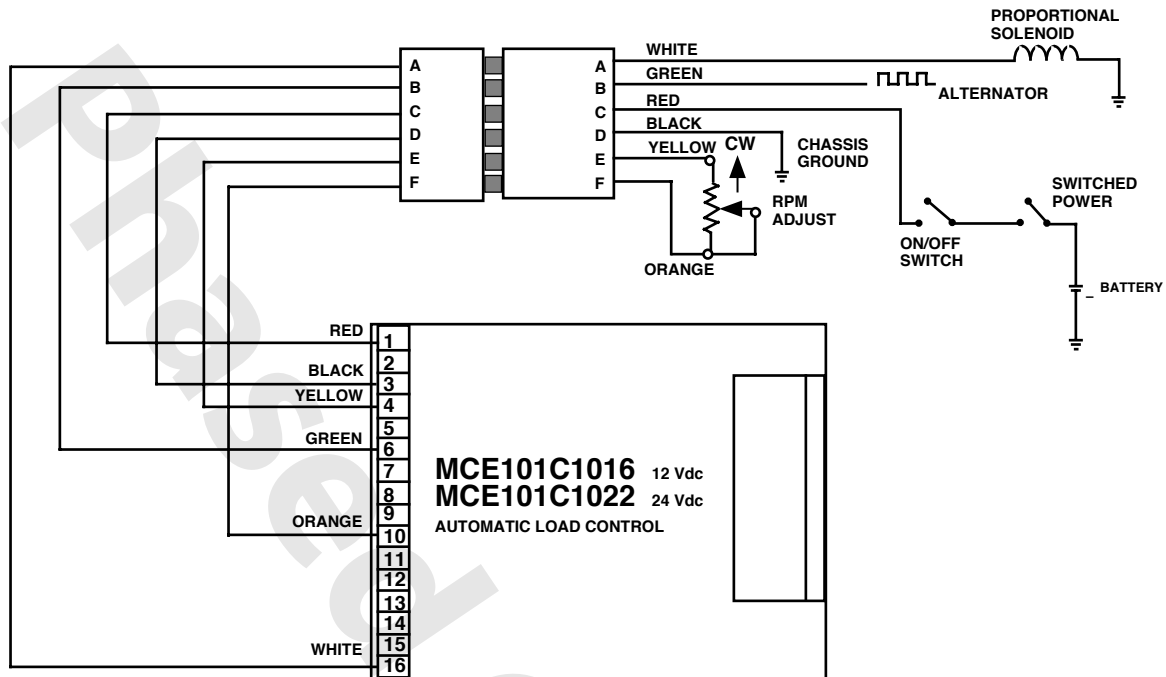

1387A

Typical Wiring Schematic for MCE101C1016 and MCE101C1022 Load Controller
With Remote AUTO/ON/OFF Switch and RPM ADJUST.

TROUBLE SHOOTING

The MCE101C should give years of trouble-free service. If the Controller fails to hold an engine RPM after having previously run properly, any one of the system components could be the problem source. All Load Controller tests should be run on Auto Mode. Check the system as follows:

1. If the voltage across MCE101C output is zero when OFF but high when ON, regardless of engine RPM, put the VOM across the alternator connection. It should read approximately 7 Vdc, indicating that the alternator is actually connected.
2. If the alternator voltage is low, check the alternator belt. A loose or broken belt should be replaced.
3. If the alternator is OK, but voltage across MCE101C output is low at high idle engine RPM, check controller voltage supply.
4. If normal electrical output shows, the valve and transmission should function properly. If not, one of them is the problem source.
5. With all power connections made, switch the Load Controller ON. This should power the solenoid valve at idle engine RPM. Attach a VOM across the valve terminals. If it reads less than 10 Vdc, the problem is in the Load Controller.
6. If the above problems have been ruled out, the Load Controller will have to be returned to the factory. It is not field-repairable. See Customer Service Section.

CUSTOMER SERVICE

NORTH AMERICA

ORDER FROM

Danfoss (US) Company
Customer Service Department
3500 Annapolis Lane North
Minneapolis, Minnesota 55447
Phone: (763) 509-2084
Fax: (763) 559-0108

DEVICE REPAIR

For devices in need of repair, include a description of the problem, a copy of the purchase order and your name, address and telephone number.

RETURN TO

Danfoss (US) Company
Return Goods Department
3500 Annapolis Lane North
Minneapolis, Minnesota 55447

EUROPE

ORDER FROM

Danfoss (Neumünster) GmbH & Co.
Order Entry Department
Krokamp 35
Postfach 2460
D-24531 Neumünster
Germany
Phone: 49-4321-8710
Fax: 49-4321-871355