

Installation Guide

Orbital Motor

Type OMT FL and OMT FH

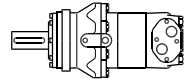

151R9941

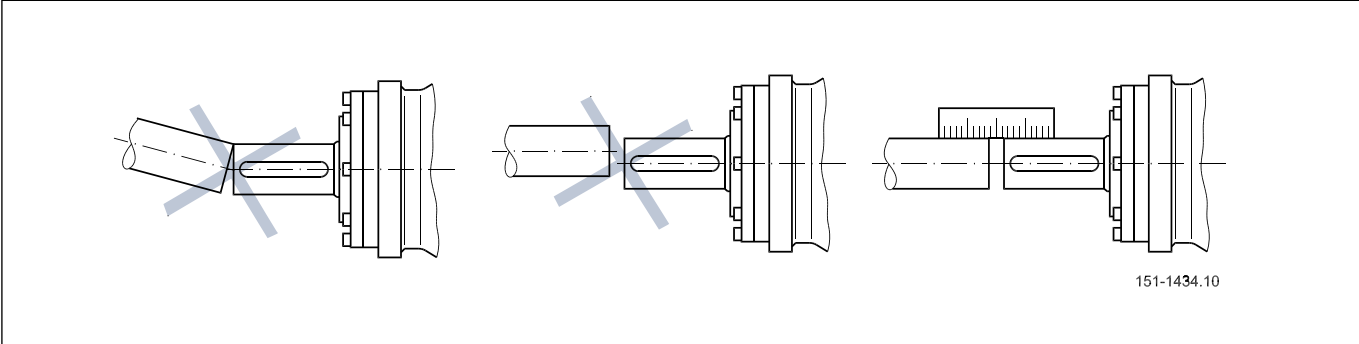

151R9941

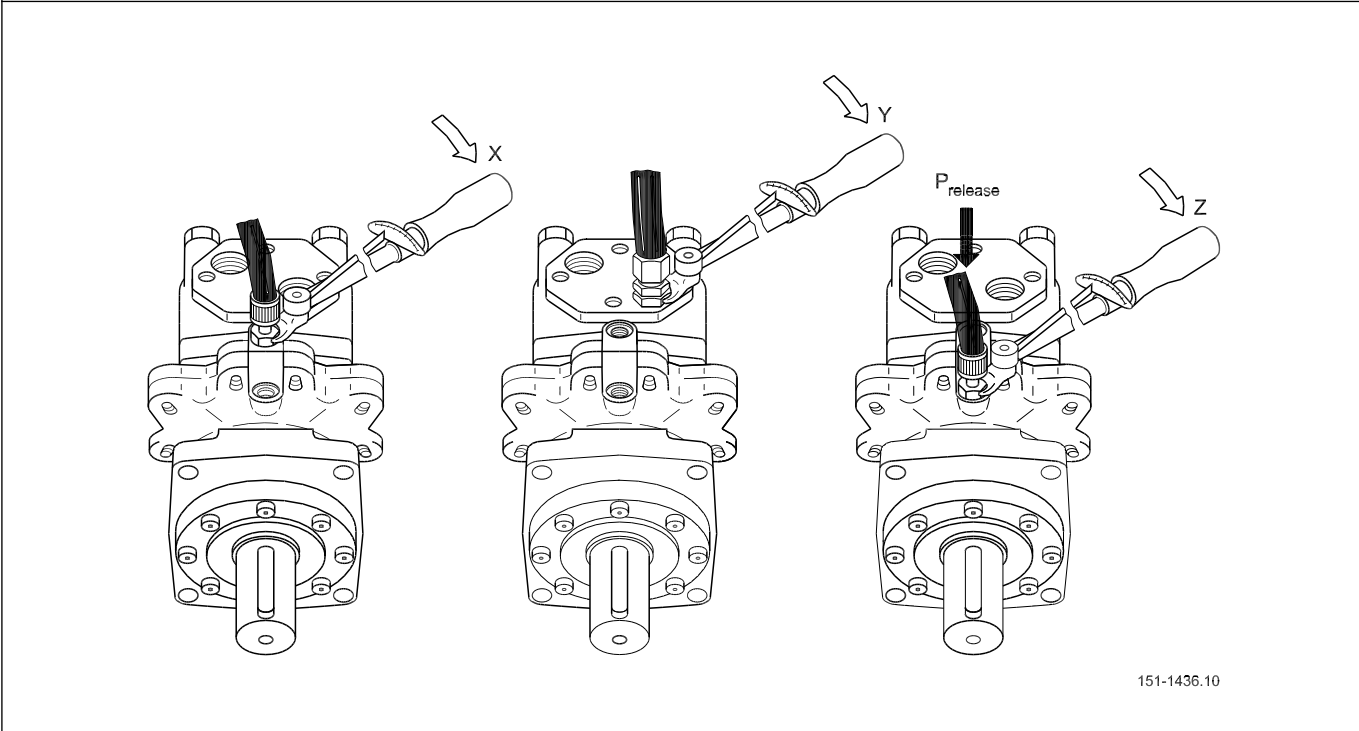
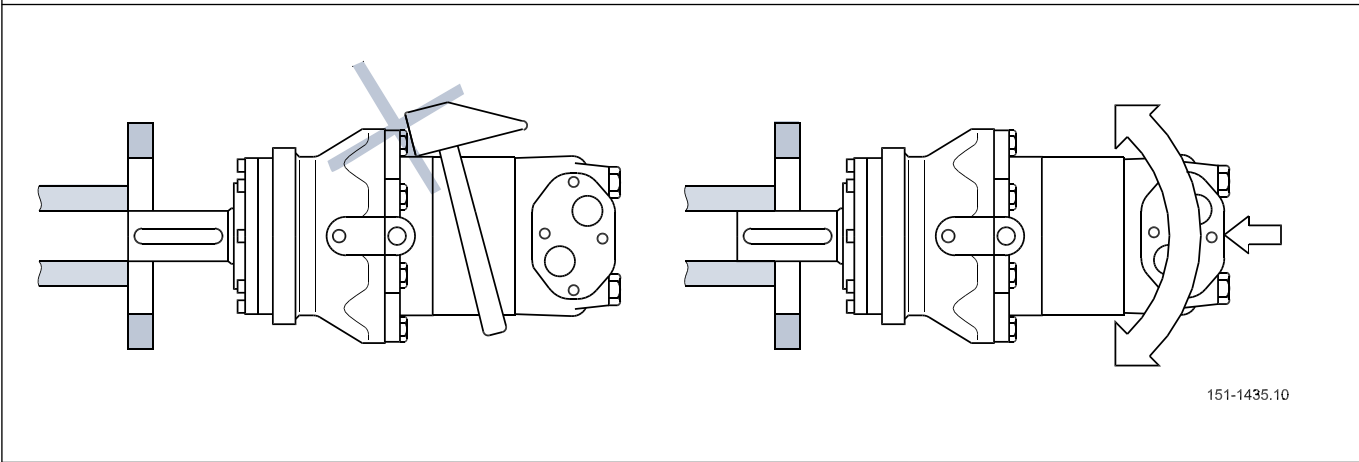

P _{release}	
OMT FL	Max. 30 bar [440 psi]
OMT FH	Max. 280 bar [4060 psi]

Max. tilspændingsmoment Max. tightening torque Max. Anzugsmoment Couple de serrage max.						
	X		Y		Z	
Forskruning Screwed connection Verschraubung Raccord	G 3/8	9/16- 18 UNF	G 3/4	1 1/8 - 12 UN	G 1/4	9/16- 20 UNF
med stålskive with steel washer mit Stahlscheibe avec rondelle en acier	60 N.m [530 lbf.in]		210 N.m [1850 lbf.in]		40 N.m [350 lbf.in]	
med aluminiumsskive With aluminium washer mit Aluminiumscheibe avec rondelle en alum	40 N.m [350 lbf.in]		110 N.m [970 lbf.in]		30 N.m [270 lbf.in]	
med skærekant with cutting edge mit Dichtkante tranchant	60 N.m [530 lbf.in]		210 N.m [1850 lbf.in]		40 N.m [350 lbf.in]	
med o-ring boss port with o-ring boss port mit O-Ring boss avec joint torique boss port		35N.m [310 lbf.in]		120 N.m [1080 lbf.in]		35 N.m [310 lbf.in]

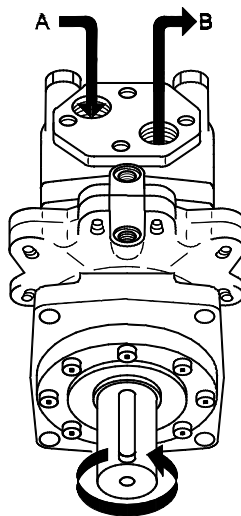
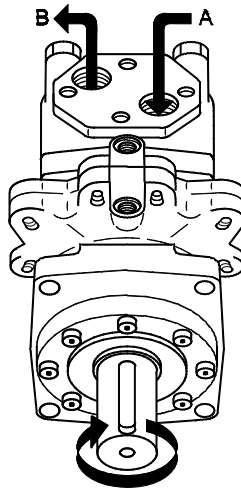

151-1437.10