

Installation Guide

Orbital Motor

Type TMVW

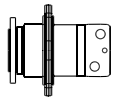

151R9903

151R9903

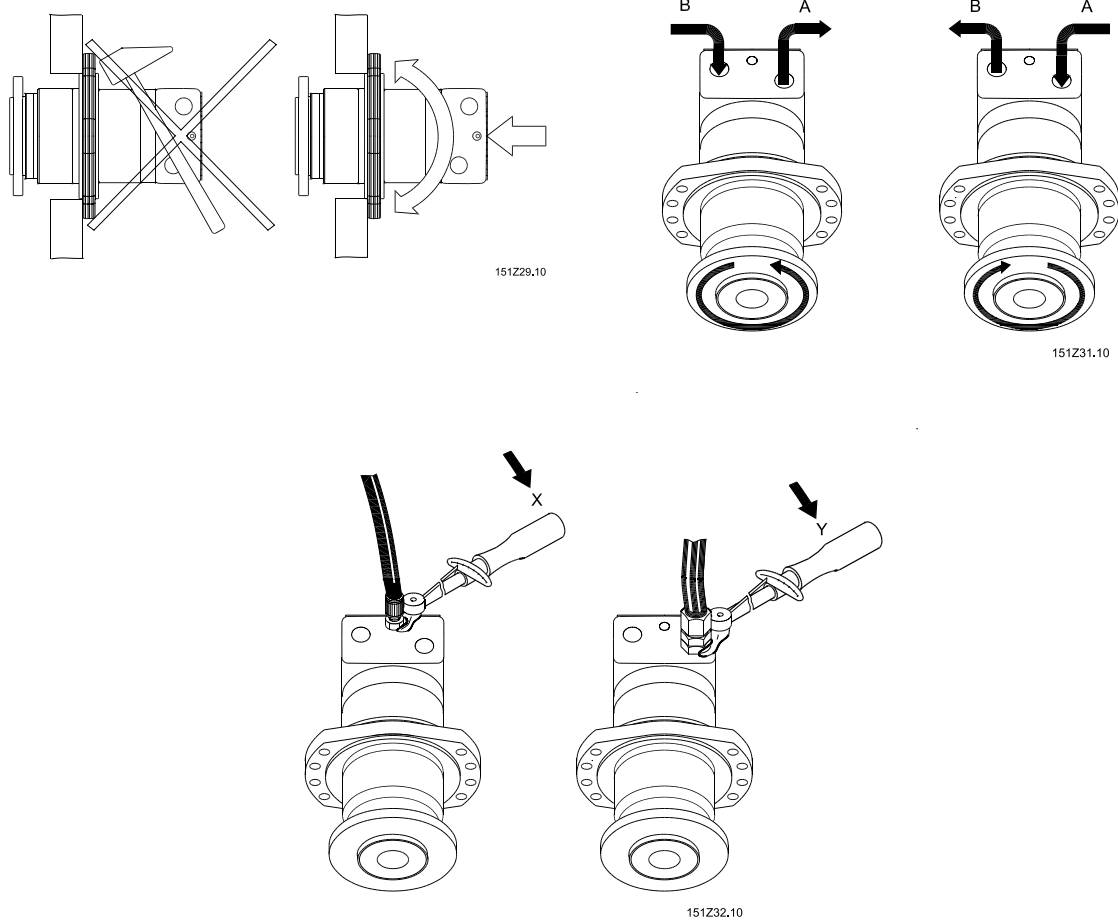

Max. tilspændingsmoment Max. tightening torque Max. Anzugsmoment Couple de serrage max.				
	X		Y	
Forskruing Screwed connection Verschraubung Raccord	G 1/4	9/16 - 18 UNF	G 1	1 5/16 - 12 UN
med stålskive with steel washer mit Stahlscheibe avec rondelle en acier	40 N.m [350 lbf.in]		280 N.m [2500 lbf.in]	
med aluminiumskive With aluminium washer mit Aluminiumscheibe avec rondelle en alum	30 N.m [270 lbf.in]		170 N.m [1300 lbf.in]	
med skærekant with cutting edge mit Dichtkante tranchant	40 N.m [350 lbf.in]		280 N.m [2500 lbf.in]	
med o-ring boss port with o-ring boss port mit O-Ring boss avec joint torique boss port		35 N.m [300 lbf.in]		160 N.m [1400 lbf.in]