

iC7 Series Liquid-cooled dU/dt Filter OF7U1/OF7U2

1 Overview

1.1 dU/dt Filter

The dU/dt Filter reduces the slew rate of the voltage pulses at the AC drive output. This reduces the stress of the motor winding isolation, but the voltage shape remains pulse-width modulated.

There are 2 electrical sizes of the OF7U1 filter: DU10L (416 A) and DU12L (820 A).

The OF7U2 filter includes a dU/dt Filter and a Common-mode Filter. The Common-mode Filter reduces bearing and ground currents, and high frequency noise in the motor cables.

There is 1 electrical size of the OF7U2 filter: DUCM10L (416 A).

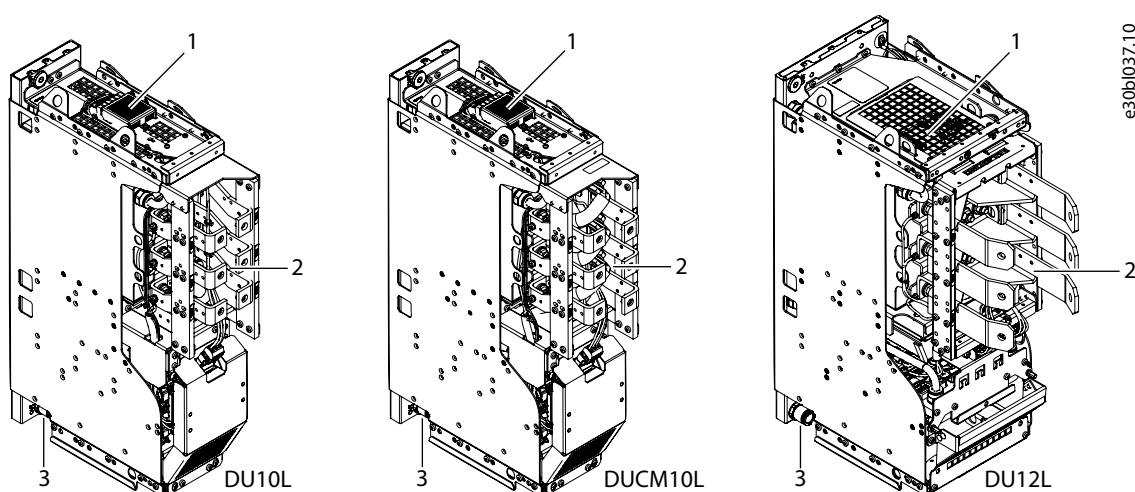

Illustration 1: Liquid-cooled dU/dt Filters

1	AuxBus temperature measurement board	3	Cooling connectors
2	Terminals		

1.2 Contents of the Delivery

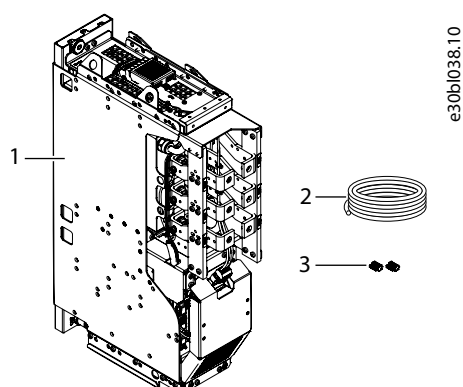

Illustration 2: Items Included in the Delivery

1	dU/dt Filter, DU10L, DUCM10L, or DU12L	3	AuxBus terminal
2	AuxBus cable, 3 m (9.8 ft)		

Available options:

- +ANN1 = Push-in cooling connectors
- +ANNC = Threaded cooling connections, metric

2 Mechanical Installation

2.1 Safety Information

⚠ WARNING ⚠

SHOCK HAZARD FROM THE COMPONENTS

The components of the drive are live when the drive is connected to mains.

- Do not make changes in the AC drive when it is connected to mains.

⚠ CAUTION ⚠

BURN HAZARD

The filter is hot during operation.

- Do not install the filter on a combustible surface.
- Do not touch the filter when hot.

Only qualified personnel are allowed to perform the installation described in this guide.

Follow the instructions in this guide and relevant local regulations.

Also read the instructions and safety information in the operating guide for the iC7 Series System Modules.

2.2 Installation Requirements

The products that are described in this guide have the protection rating IP00/UL Open Type. Install them in a cabinet or other enclosure that has a correct level of protection against the ambient conditions in the installation area. Make sure that the cabinet gives protection against water, humidity, dust, and other contaminations.

The cabinet must also be sufficiently strong for the weight of the system modules and other devices.

The protection rating of the cabinet must be at least IP21/UL Type 1. When preparing the installation, obey the local regulations.

2.3 Installing the Filter into a Cabinet

Procedure

1. Install the filter into the cabinet in a vertical or horizontal position.

See [2.4 Dimensions of the dU/dt Filter](#).

2. Attach the filter from the mounting holes on the frame to the cabinet.

For aluminum parts, use M6 grade 8.8 screws with a thread depth of 6–14 mm (0.24–0.55 in), and a tightening torque of 6–8 Nm (53–71 in-lb).

For sheet metal parts, use M5 (DIN 7500) screws with a maximum thread depth of 20 mm (0.79 in), and a tightening torque of 3–4 Nm (27–35 in-lb).

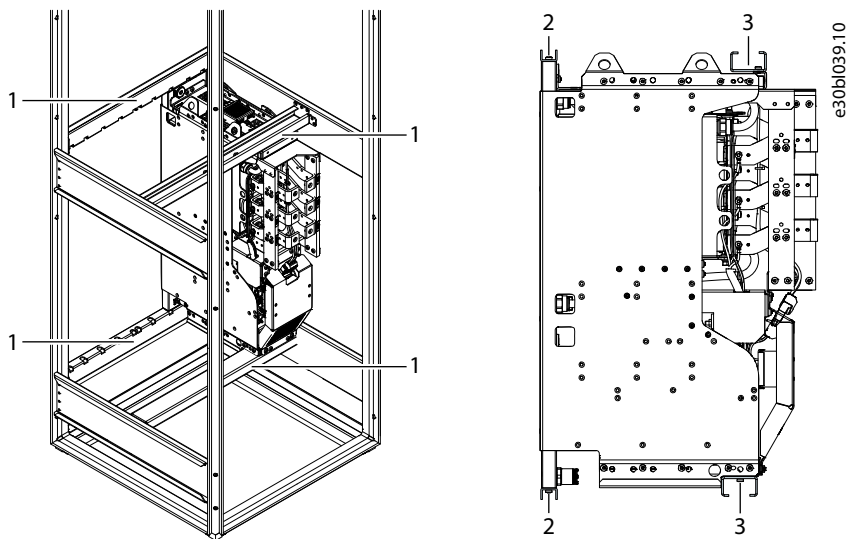

Illustration 3: Example of Mounting the dU/dt in the Cabinet Vertically

<p>1 Mounting brackets</p>	<p>3 Mounting holes in sheet metal parts</p>
<p>2 Mounting holes in aluminum parts</p>	

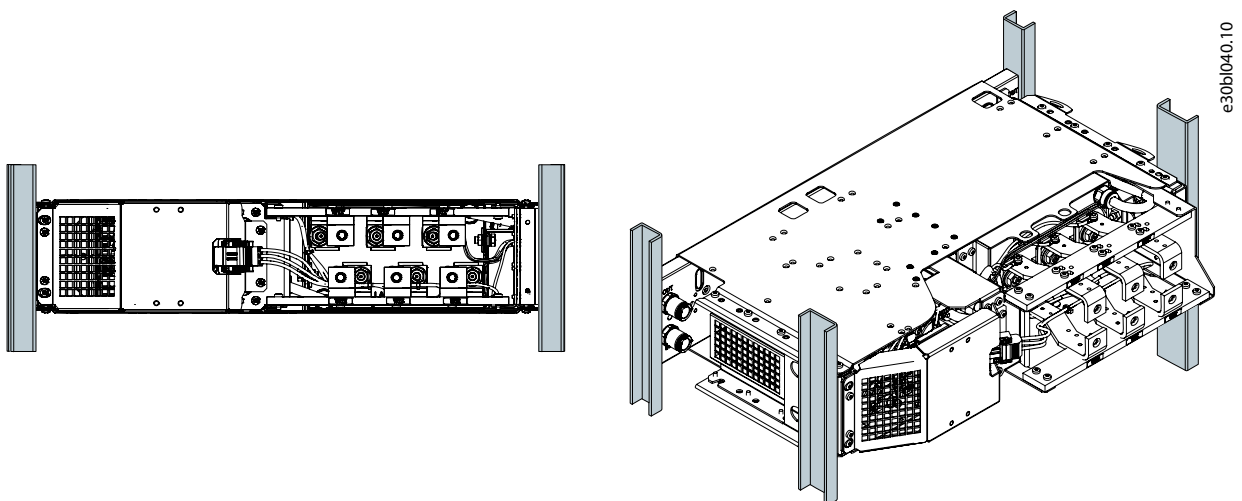

Illustration 4: Example of Mounting the dU/dt Horizontally

2.4 Dimensions of the dU/dt Filter

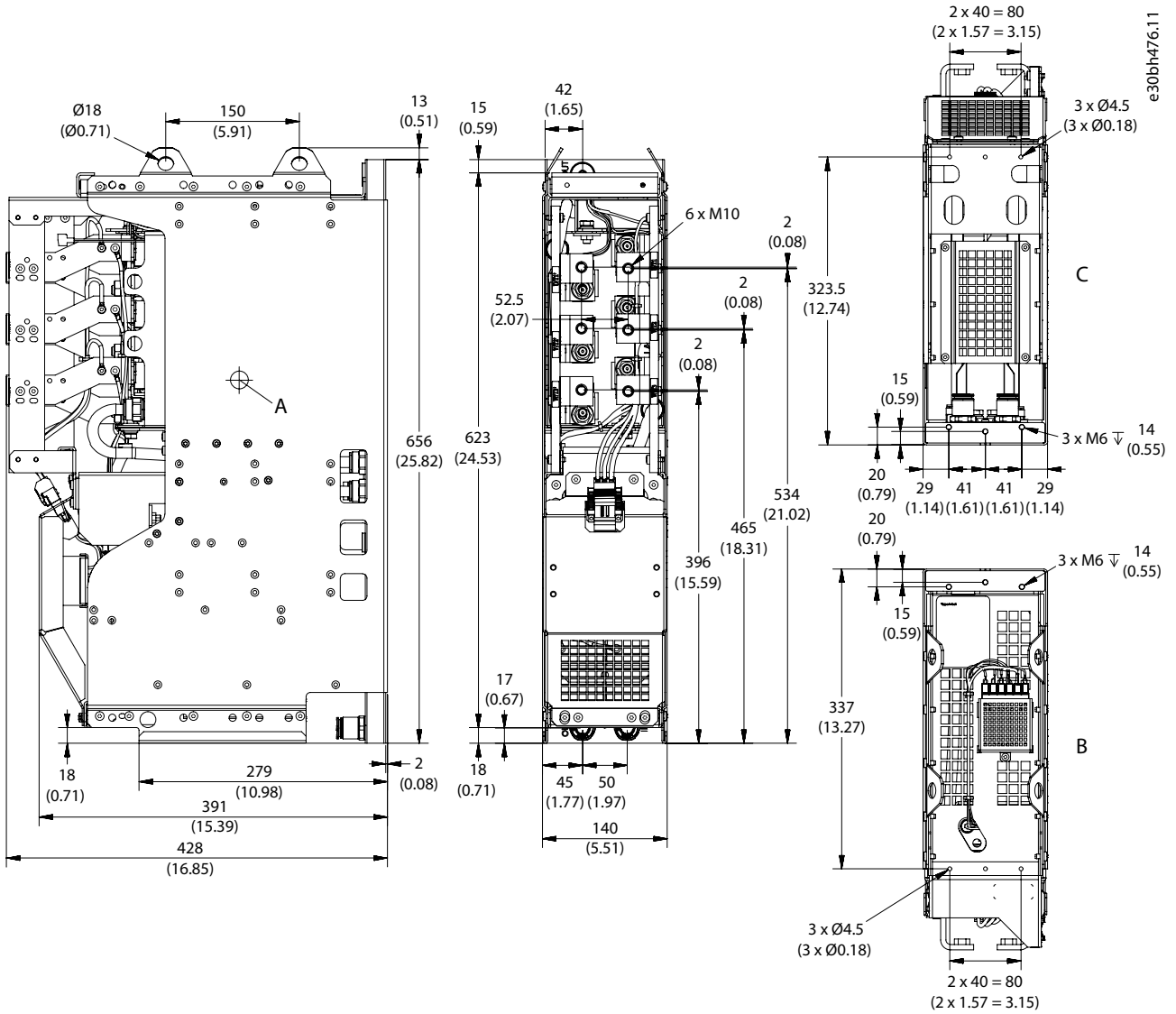

Illustration 5: Dimensions of the dU/dt Filter DU10L, in mm (in)

A	Center of gravity	C	View from the bottom
B	View from the top		

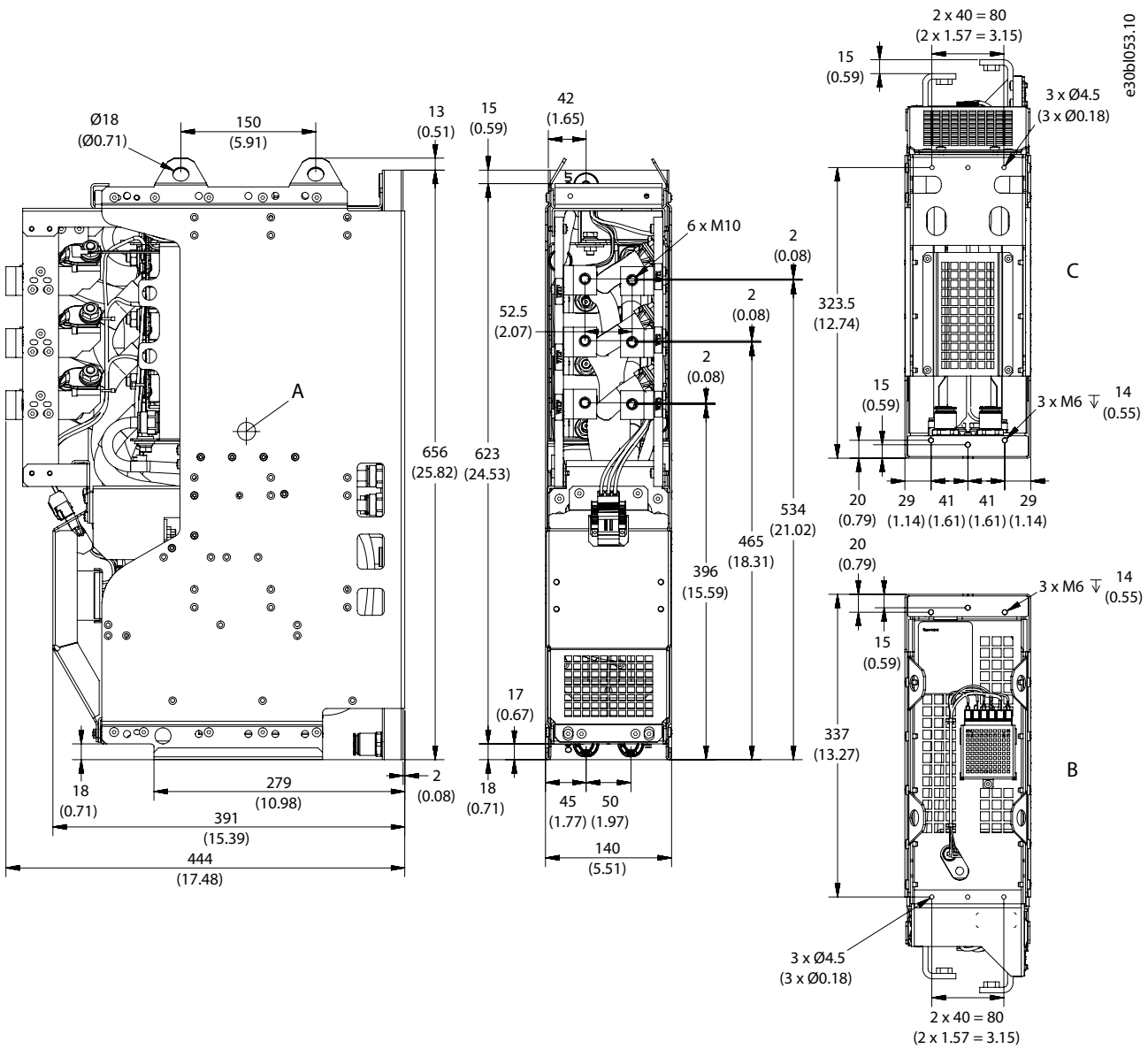

Illustration 6: Dimensions of the dU/dt and Common-mode Filter DUCM10L, in mm (in)

A	Center of gravity	C	View from the bottom
B	View from the top		

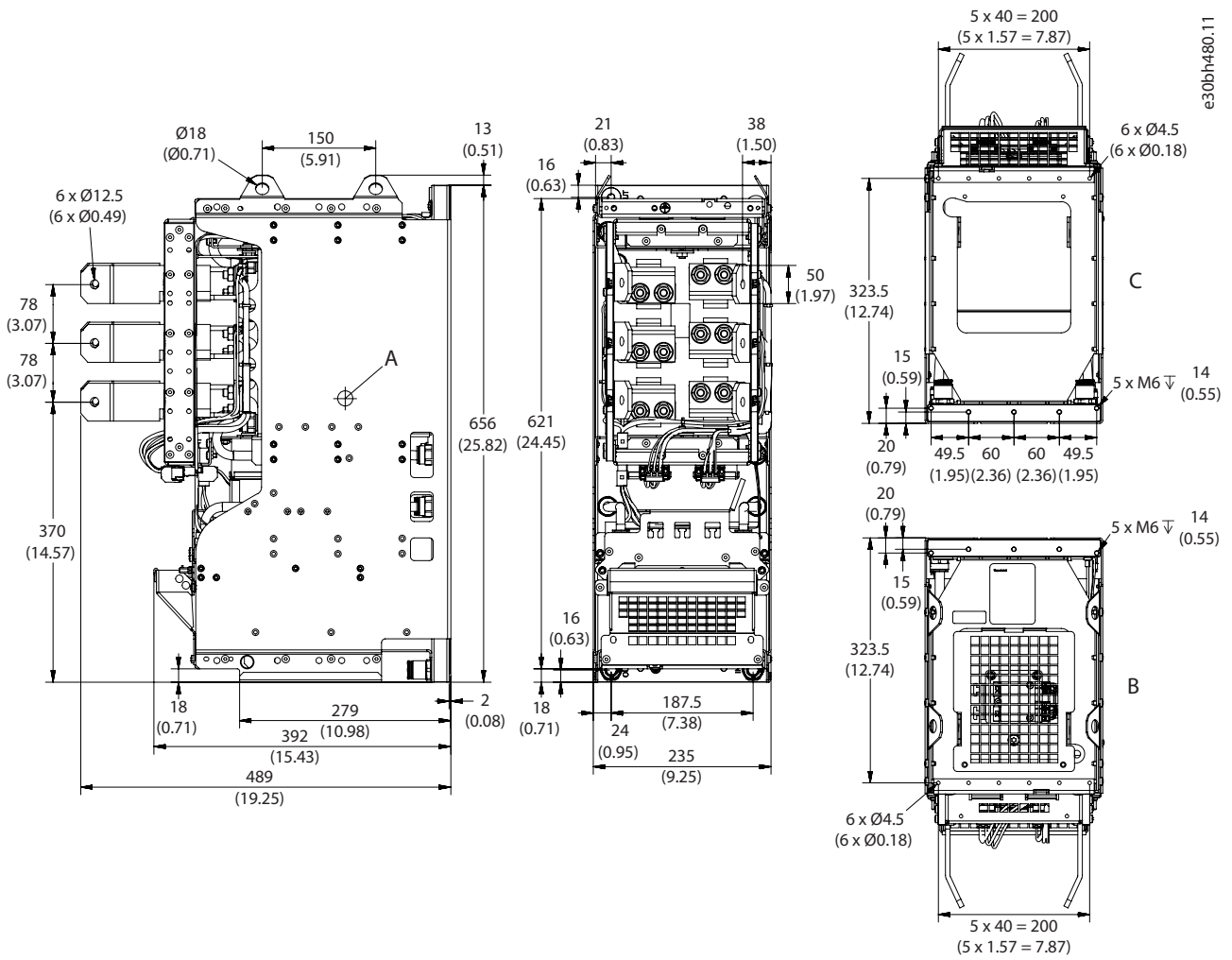

Illustration 7: Dimensions of the dU/dt Filter DU12L, in mm (in)

A	Center of gravity	C	View from the bottom
B	View from the top		

3 Cooling Requirements

3.1 Safety in Liquid-cooling

⚠ WARNING ⚠

POISONOUS COOLANTS

Glycols and inhibitors can be poisonous. If touched or consumed, they can cause injury.

- Prevent the coolant from getting into the eyes.
- Do not drink the coolant.

⚠ CAUTION ⚠

HOT COOLANT

Hot coolant can cause burns.

- Avoid contact with the hot coolant.

⚠ CAUTION ⚠

PRESSURIZED COOLING SYSTEM

Sudden release of pressure from the cooling system can cause injury.

- Be careful when operating the cooling system.

N O T I C E

INSUFFICIENT COOLING CAPACITY

Insufficient cooling can cause the product to become too hot and thus become damaged.

- To make sure that the cooling capacity of the cooling system stays sufficient, make sure that the cooling system is vented, and that the coolant circulates properly.

N O T I C E

DAMAGE TO COOLING SYSTEM

If the coolant circulation is stopped too soon, high temperature components can cause rapid local increase in the coolant temperature, which can damage the cooling system.

- Do not stop the cooling system when stopping the drive. Keep the coolant circulation flowing for 2 minutes after the drive has been stopped.

3.2 General Information on Cooling

N O T I C E

For more detailed information about the requirements for liquid-cooling, see the iC7 Series Liquid-cooled System Modules Operating Guide.

The product is cooled with liquid. The liquid circulation of the drive is usually connected to a heat exchanger (liquid-to-liquid or liquid-to-air) that cools down the liquid circulating in the cooling elements. The cooling elements are made of aluminum.

If there is no risk of freezing, purified water can be used as coolant. Freezing water permanently damages the cooling system. Purified water is demineralized, deionized, or distilled water.

The allowed antifreeze coolants are the following ethylene glycols and propylene glycols.

- **Ethylene glycols:** DOWCAL 100 or Clariant Antifrogen N
- **Propylene glycols:** DOWCAL 200 or Clariant Antifrogen L

These glycols already include corrosion inhibitors. Do not add any other inhibitor. Do not mix different glycol qualities because there can be harmful chemical interactions.

The glycol concentration of the coolant must be 25–55% by volume, according to the specified ambient temperature. Higher concentration reduces cooling capacity. Lower concentration results in biological growth and inadequate amount of corrosion inhibitors. Antifreeze must be mixed with purified water.

To gain full performance of the product, the temperature of the coolant entering the system module must be a maximum of 45 °C (113 °F). Typically, 95% of the power losses are dissipated in the coolant. It is recommended to equip the cooling circulation with temperature supervision.

The minimum nominal flow rate of the coolant:

- 18.5 l/min (4.89 gal/min) with water
- 24.1 l/min (6.37 gal/min) with 30% glycol
- 27.8 l/min (7.34 gal/min) with 50% glycol

The liquid volume per element:

- OF7U1/OF7U2, 416 A: 0.68 l (0.180 gal)
- OF7U1, 820 A: 1.34 l (0.354 gal)

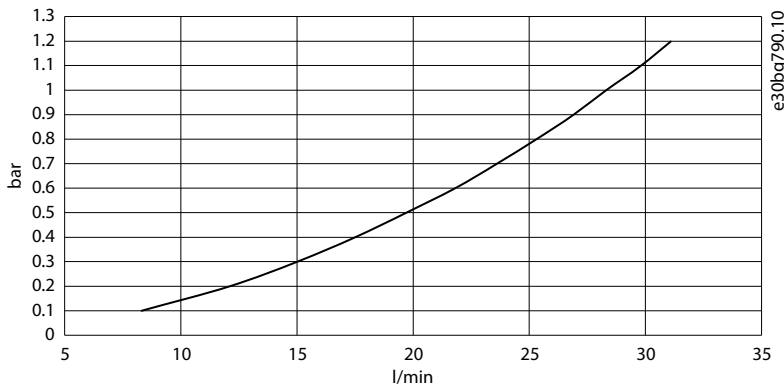

Illustration 8: Pressure Drop with Water, dU/dt Filter OF7U1/OF7U2, 416 A

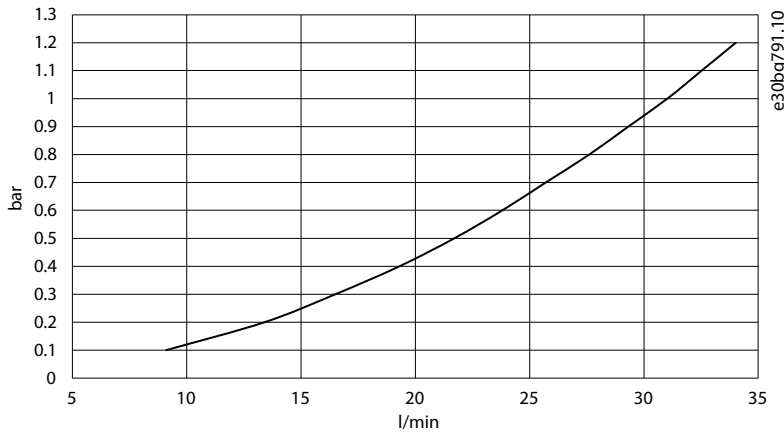

Illustration 9: Pressure Drop with Water, dU/dt Filter OF7U1, 820 A

3.3 Cooling Circuit Connectors

The dU/dt Filter has cooling circuit connectors in the manifold plate. The internal thread size is G1/2. The depth of the threads is 13 mm (0.51 in). The maximum tightening torque is 30 Nm (265 in-lb). Push-in connectors are available as option +ANN1.

The inlet and outlet connectors are at the bottom of the filter. An alternative outlet connector is available at the top of the filter.

If the optional outlet connector at the top is used, the outlet connector at the bottom must be closed with a plug.

Do not connect filters in series. Connecting in series requires high flow rates and high pressure because of the temperature rise of the coolant in the filters.

Table 1: Recommended Connectors

Connector	Tightening torque	Pipe	Pipe ferrule
Parker 69111621 MALE STUD 1/2"BSPP SS STEEL 31 6L D16 EPDM SEAL	20–30 Nm (177–265 in-lb)	PA 16/13 pipe	Parker 1827-16-13

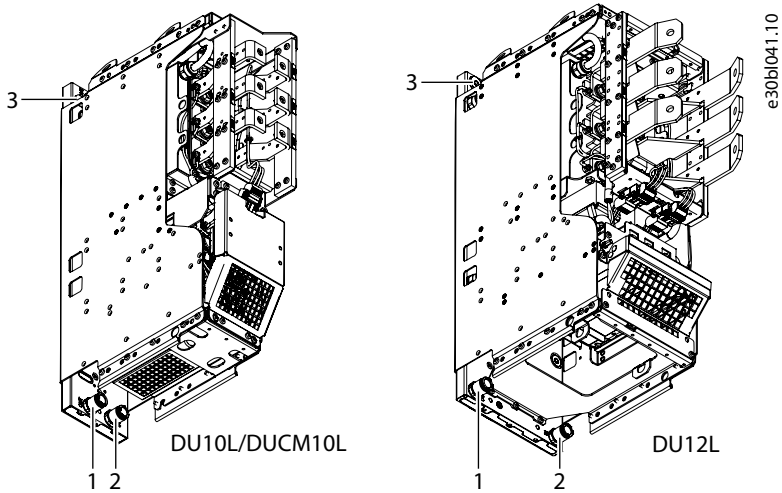

Illustration 10: Location of the Cooling Circuit Connectors

1	Outlet connector	3	Alternative outlet connector
2	Inlet connector		

4 Electrical Installation

4.1 Electrical Installation Safety

⚠ WARNING ⚠

OVERHEATED CABLES

Overheated cables are a fire hazard.

- Because of several possible cable installations and environmental conditions, it is important to consider local regulations and IEC/EN standards.

Route the wires away from sharp edges, screw threads, burrs, fins, moving parts, drawers, and similar parts, which can abrade the wire insulation.

For the main circuit, use double insulated wires or protect the wires with, for example, a protective sleeve or wrap to minimize the risk of short circuit. Maintain separation between the main and control circuit wires.

4.2 Installing the dU/dt Filter

Install the dU/dt Filter at the inverter output. If the inverter has parallel power units, install a separate dU/dt Filter at the output of each power unit. See [Illustration 17](#).

4.3 Cable Requirements

For information about recommended cable types and required cable sizes, see the iC7 Series Liquid-cooled System Modules Operating Guide.

4.4 Grounding

Ground the filter in accordance with applicable standards and directives.

Unless local wiring regulations state otherwise, the cross-sectional area of the protective grounding conductor must be at least ½ times of the phase conductor and made of the same material when the phase conductor cross-section is above 35 mm² (AWG 2) according to IEC 60364-5-54; 543.1.

The connection must be fixed.

4.5 Installing the Cables

Procedure

1. Connect the AC cables from the inverter module to terminals U', V', and W'.

Use M10 screws and tightening torque 35–40 Nm (310–354 in-lb).

2. Connect the motor phase cables to terminals U, V, and W.

Use M10 screws and tightening torque 35–40 Nm (310–354 in-lb).

3. Connect the grounding cable to the PE terminal.

Use M8 screws and tightening torque 17–20 Nm (150–177 in-lb).

4.6 Terminals

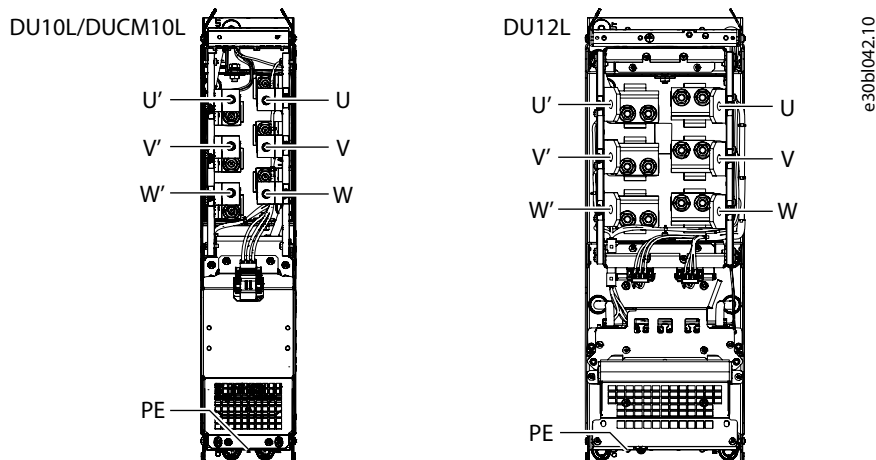

Illustration 11: Terminals of the dU/dt Filter

Table 2: dU/dt Filter Terminal Descriptions

Terminal	Description
U/T1 V/T2 W/T3	Connection point for motor output
U/T1' V/T2' W/T3'	Connection point for inverter module to dU/dt Filter
PE	Grounding terminal for filter frame

4.7 Preparing the AuxBus Cable

1. Cut the cable to the required length.
2. To reveal the wires, strip the cable at both ends.
3. At 1 end of the cable, remove approximately 15 mm (0.59 in) of the insulation of the cable.
4. Strip the wires 7 mm (0.28 in).
5. Connect the wires to the terminals included in the delivery. Use the tightening torque 0.22–0.25 Nm (1.9–2.2 in-lb).

Table 3: Wiring of the AuxBus Terminals

Pin	Wire color	Signal
1	White	+24 V
2	Brown	GND
3	Green	CAN_H
4	Yellow	CAN_L
5	Grey	+24 V

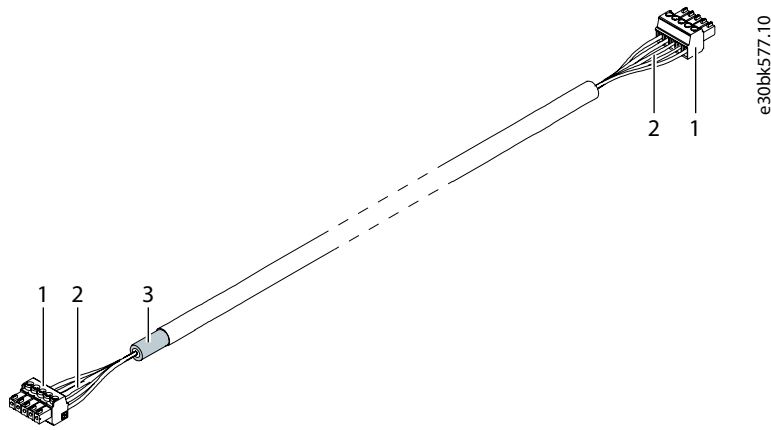

Illustration 12: The Ready AuxBus Cable

1	Terminals	3	Shield removed
2	Wires		

4.8 AuxBus Connections

NOTICE

For the drive to be able to protect the filters, AuxBus must be connected.

For more information about AuxBus, see the iC7 Series System Module operating guides.

Procedure

1. To access the AuxBus temperature measurement board, remove the cover.

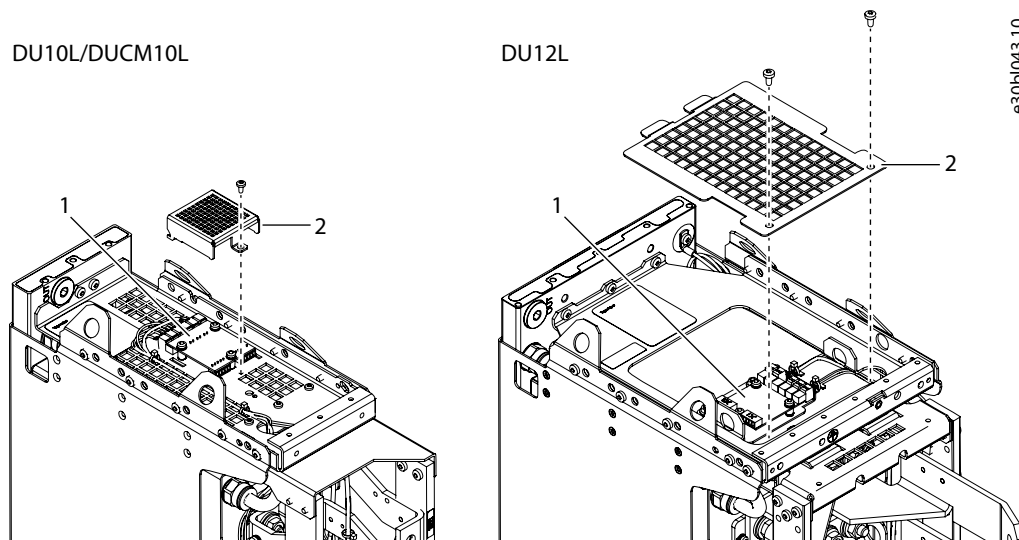

Illustration 13: Accessing the AuxBus Temperature Measurement Board

1	AuxBus temperature measurement board
2	Cover

2. Connect the AuxBus cable between the filter and the power unit. If there are several power units and filters, connect each filter to the power units individually.
 - a. Connect the end of the AuxBus cable where the insulation was removed to terminal X79 on the power unit.
 -

- b. Connect the other end of the AuxBus cable to terminal X86 on the AuxBus temperature measurement board.

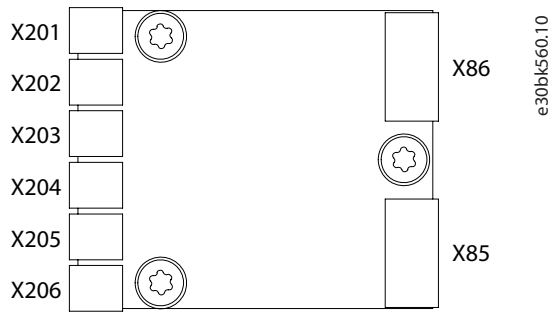

Illustration 14: Terminals on the AuxBus Temperature Measurement Board

X206	Temperature measurement input	X86	AuxBus out
X85	AuxBus in		

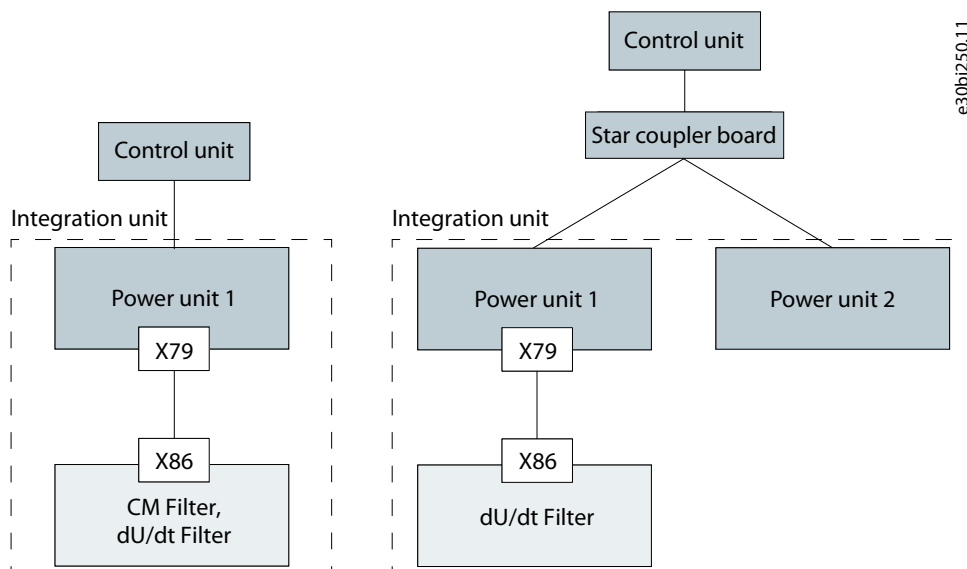

Illustration 15: AuxBus Topology

- Route the cable so that there is no risk of getting in touch with bare busbars or terminals.
- Ground each AuxBus cable at 1 end at the X79 terminal. To make the grounding connection, attach the shield of the cable to the frame with a cable clamp.

The lower part of the cable clamp fixes the cable to the plate and provides strain relief. The upper part provides ~360° grounding for the cable shield.

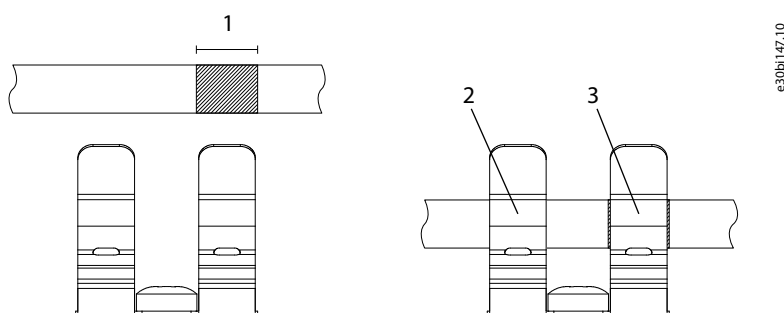

Illustration 16: Using the Cable Clamps

1	Stripping length, 15 mm (0.59 in)	3	Grounding
2	Strain relief		

5. At the terminal X86 end of the cable, place the cable in a cable clamp for strain relief.

4.9 Wiring Diagrams

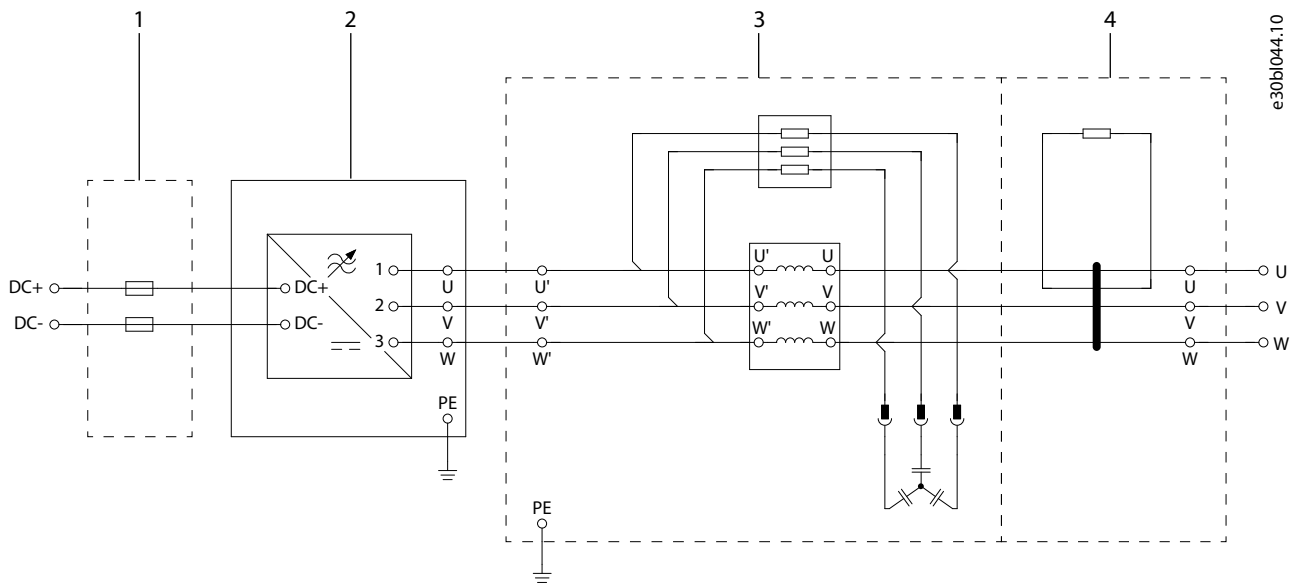

Illustration 17: Wiring Diagram, DU10L and DUCM10L

1	DC fuses, loose option	3	dU/dt Filter DU10L/DUCM10L
2	Inverter module IM10L	4	Common-mode Filter, included only in DUCM10L

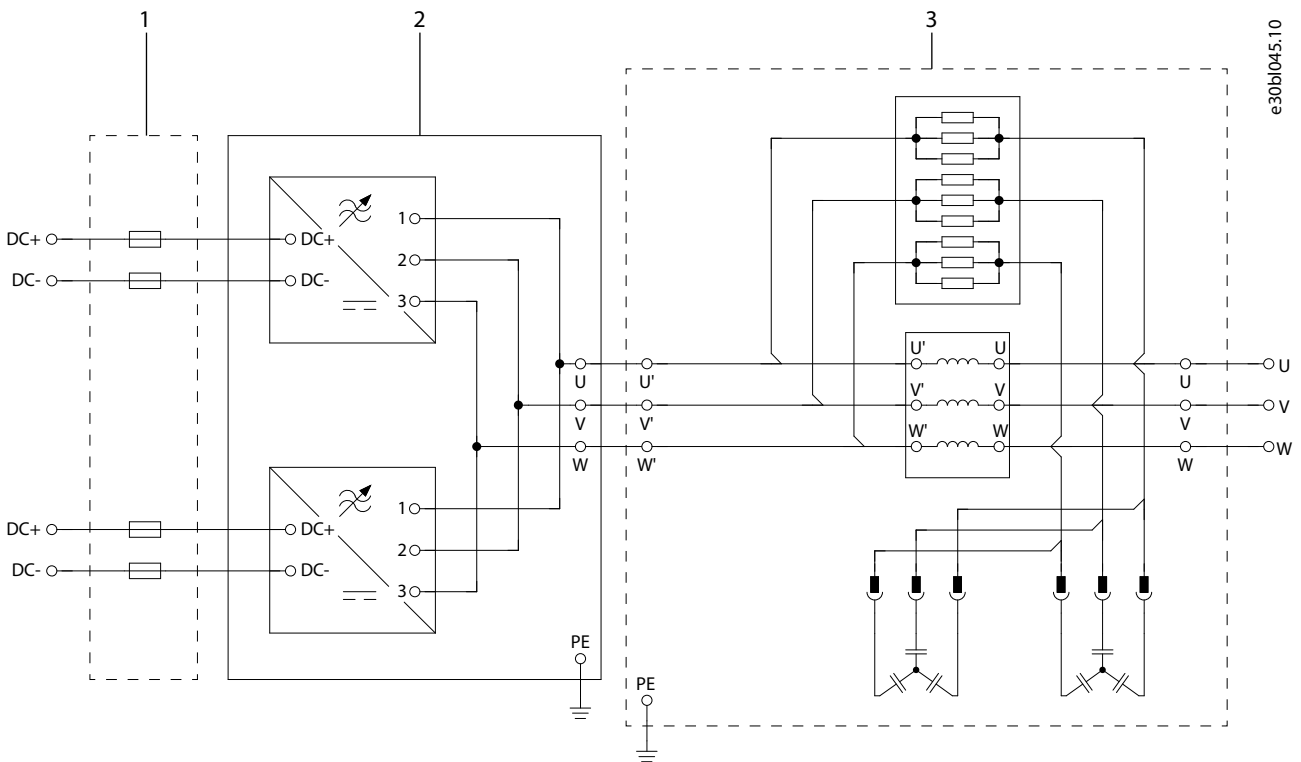

Illustration 18: Wiring Diagram, DU12L

1	DC fuses, loose option	3	dU/dt Filter DU12L
2	Inverter module IM12L		

Vacon Ltd, Member of the Danfoss Group
 Runsorintie 7
 FIN-65380 Vaasa
www.danfoss.com

Danfoss can accept no responsibility for possible errors in catalogs, brochures and other printed material. Danfoss reserves the right to alter its products without notice. This also applies to products already on order provided that such alterations can be made without subsequent changes being necessary in specifications already agreed. All trademarks in this material are property of the respective companies. Danfoss and the Danfoss logotype are trademarks of Danfoss A/S. All rights reserved.

