

Decoupling Plate Mounting Kit for MA02c/ MA02a/MA03a/MA04a/MA05a

iC2-Micro Frequency Converters

1 Overview

1.1 Description

This installation guide explains how to install the decoupling plate mounting kit for enclosure sizes MA02c, MA02a, MA03a, MA04a, and MA05a of iC2-Micro Frequency Converters.

1.2 Kit Numbers

Use these instructions with the following kits.

Table 1: Kit Numbers for Decoupling Plate Mounting Kits

Kit number	Kit description
132G0203	Decoupling plate mounting kit, MA02c
132G0205	Decoupling plate mounting kit, MA02a/MA03a
132G0206	Decoupling plate mounting kit, MA04a/MA05a

1.3 Items Supplied

The following parts are contained in the kit.

Table 2: Items Supplied in Decoupling Plate Mounting Kits

Item	Quantity
Power decoupling plate	1
Cable clamp	2
U-terminal (for MA02c/MA02a/MA03a)	2–3 (depends on enclosure size)
Terminal strap (for MA04a/MA05a)	2
M4x10 screw	2–4 (depends on enclosure size)
M4x20 screw (for MA02c/MA02a/MA03a)	4
M4x30 screw (for MA04a/MA05a)	4

1.4 Safety Precautions

Only qualified personnel are allowed to install the decoupling plate mounting kit described in this installation guide.

For important information about safety precautions for installation, refer to the drive's operating guide.

⚠ W A R N I N G ⚠

DISCHARGE TIME

The drive contains DC-link capacitors, which can remain charged even when the drive is not powered. High voltage can be present even when the warning indicator lights are off.

- Stop the motor, disconnect AC mains, permanent magnet type motors, and remove DC-link supplies, including battery back-ups, UPS, and DC-link connections to other drives.
- Wait for the capacitors to discharge fully and measure it before performing any service or repair work.
- The minimum waiting time is 4 minutes for MA02c and MA02–03a drives, and 15 minutes for MA04–05a drives.

2 Installation

2.1 Mounting the Decoupling Plate Mounting Kit

Procedure

1. Release 2 screws from drive, mount the power decoupling plate on the drive and fasten with 2 screws, see [Illustration 1](#).
Maximum tightening torque: 2 Nm (17.7 in-lb).

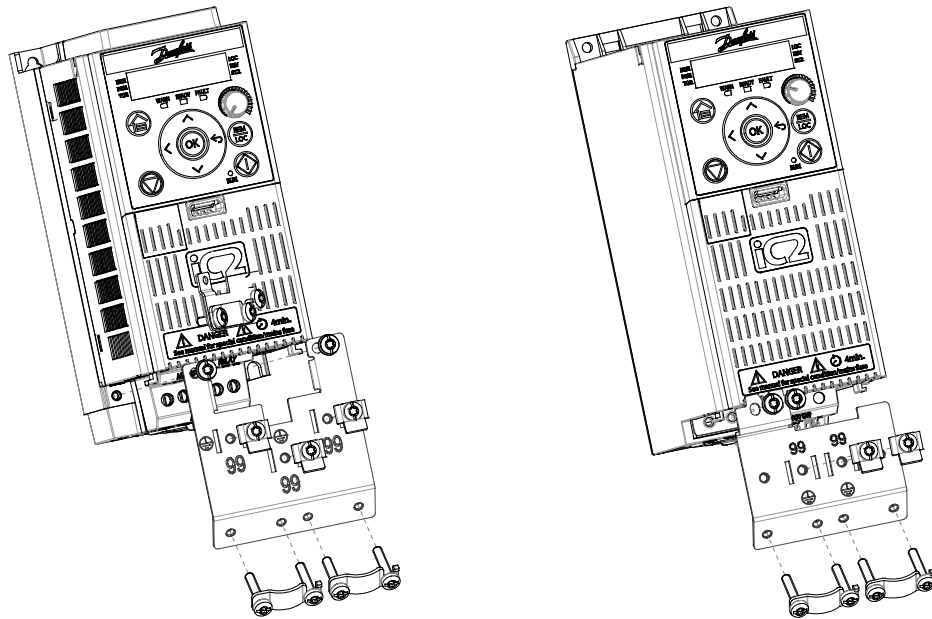

MA02c

MA02a-MA03a

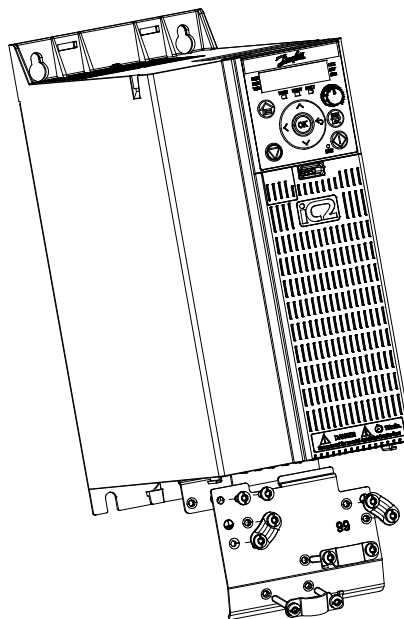

MA04a-MA05a

Illustration 1: Mounting Decoupling Plate

e30bv152.10

- 2. See [Illustration 2](#) for the drive mounted with decoupling plate.

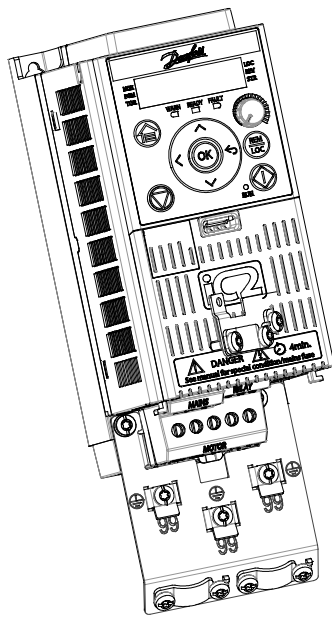

MA02c

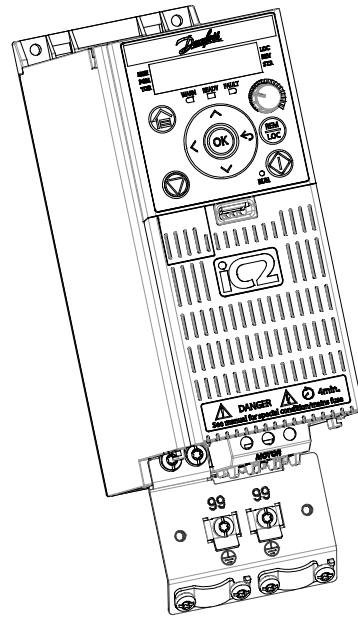

MA02a-MA03a

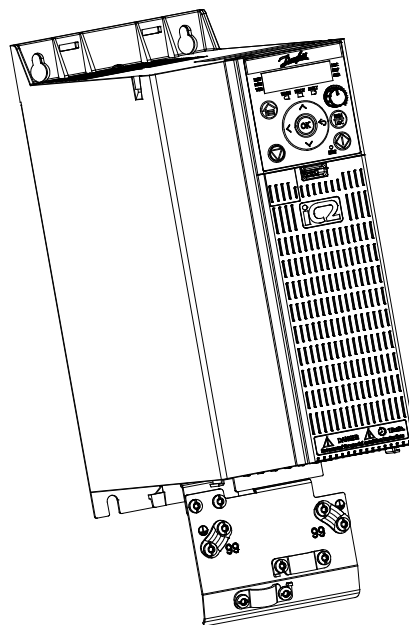

MA04a-MA05a

Illustration 2: Drive Mounted with Decoupling Plate

e30bv153.10

Danfoss A/S
Ulsnaes 1
DK-6300 Graasten
drives.danfoss.com

Danfoss can accept no responsibility for possible errors in catalogs, brochures, and other printed material. Danfoss reserves the right to alter its products without notice. This also applies to products already on order provided that such alterations can be made without subsequential changes being necessary in specifications already agreed. All trademarks in this material are property of the respective companies. Danfoss and the Danfoss logotype are trademarks of Danfoss A/S. All rights reserved.

M0035801

