

Installation Guide

AK-CC55

Multi Coil



084R8055



AN300030680307en-000301

Identification

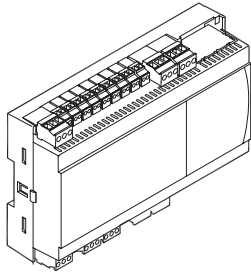

084B4084

Dimensions

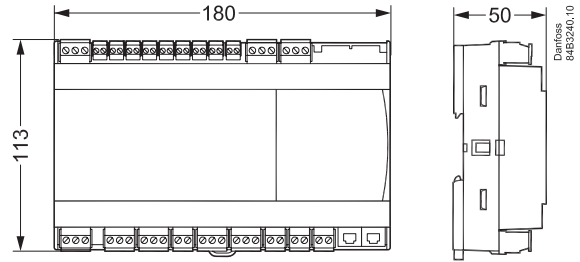

Principle

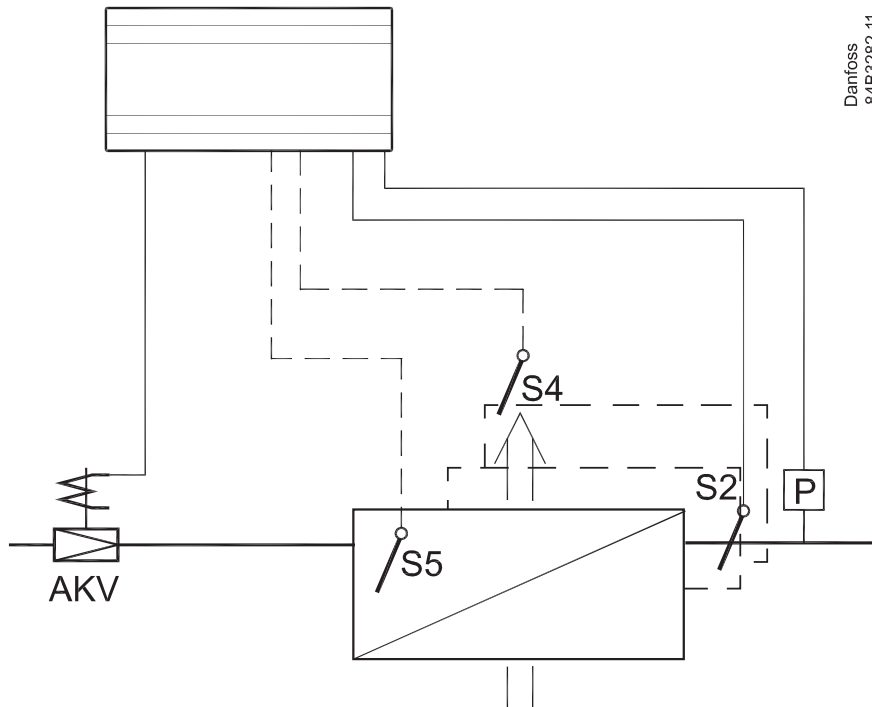

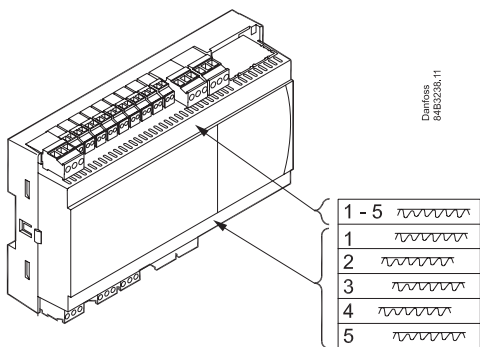

The controller is provided with labels from the factory indicating a generic application. When selecting the required application, specific labels are provided so that you can mount the relevant one.

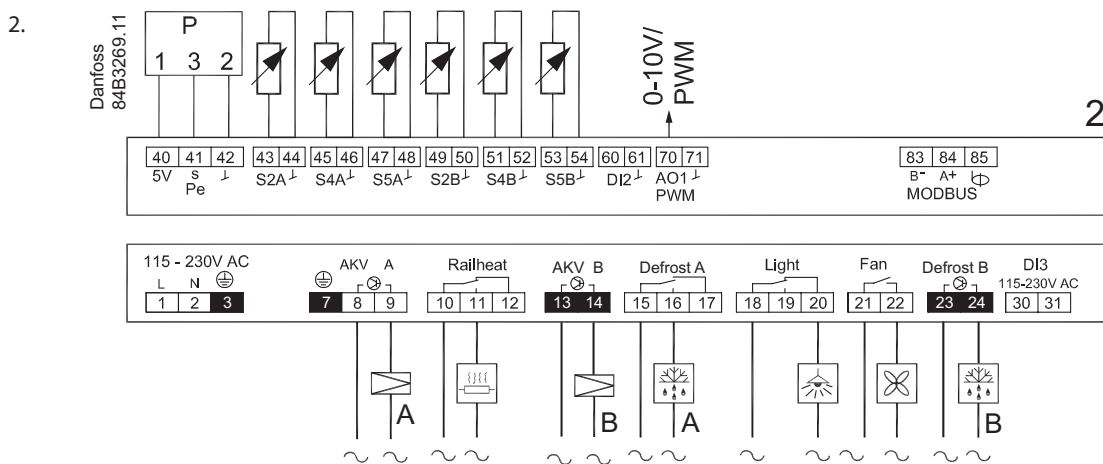
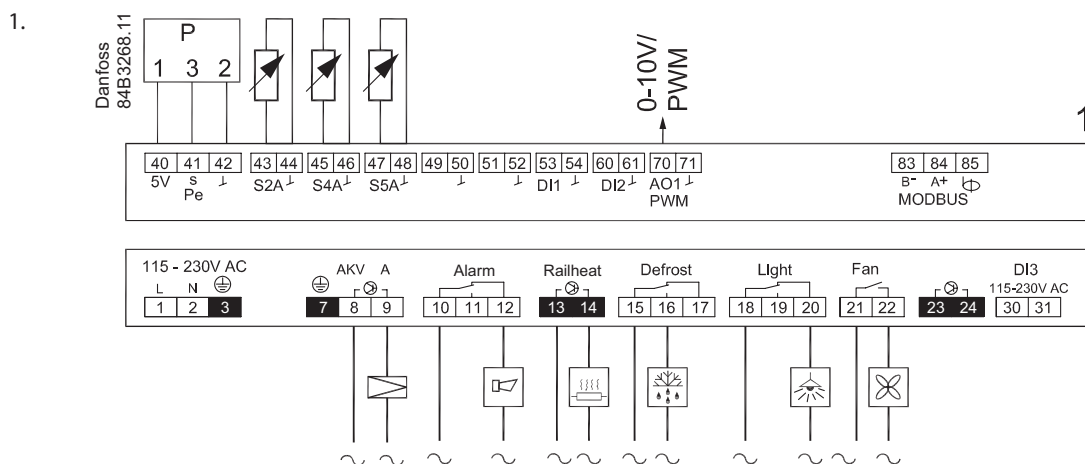

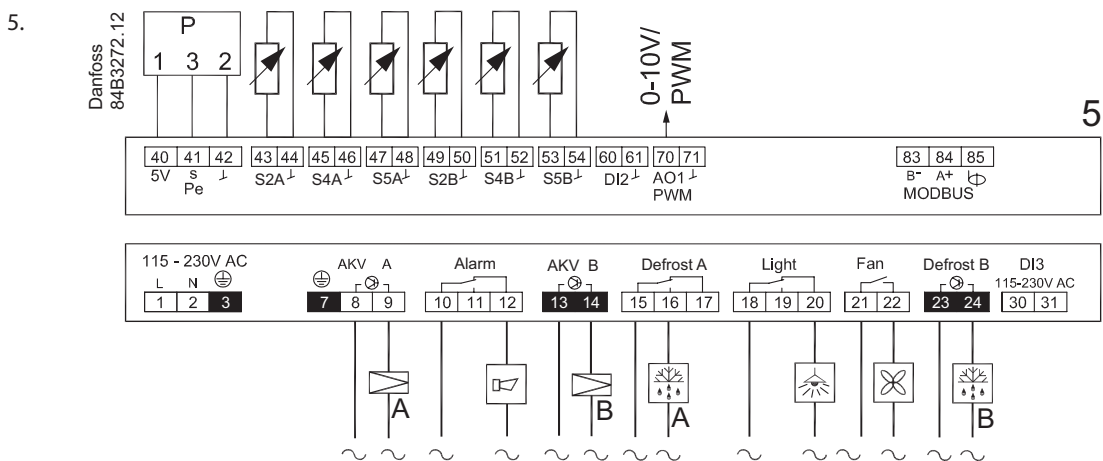
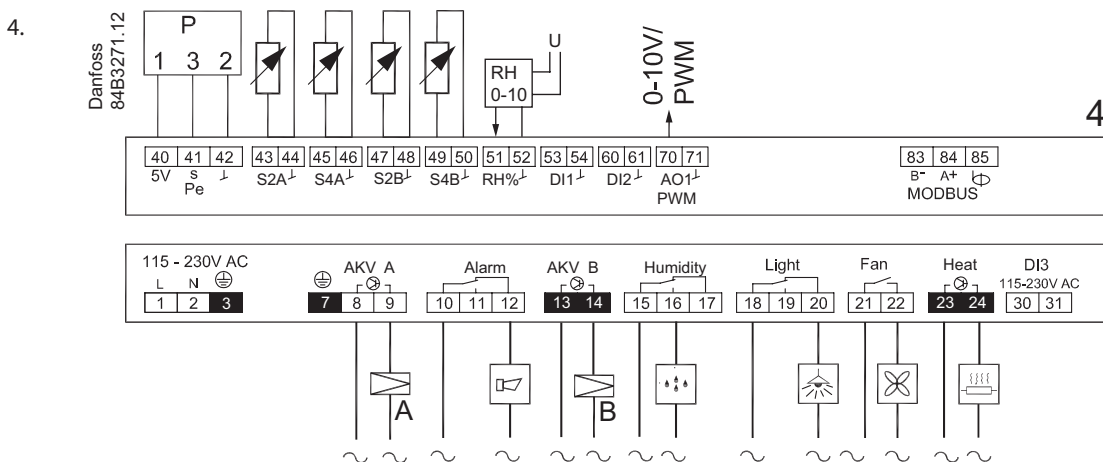
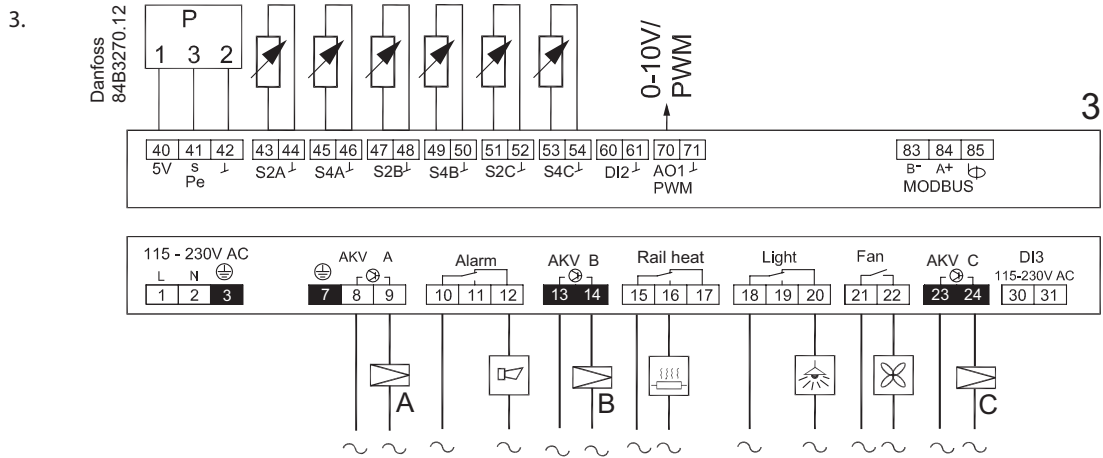

Data communication

Important

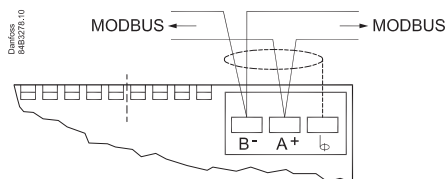

It is important that the installation of the data communication cable is performed correctly. See separate literature no. RC8AC902

AKV info

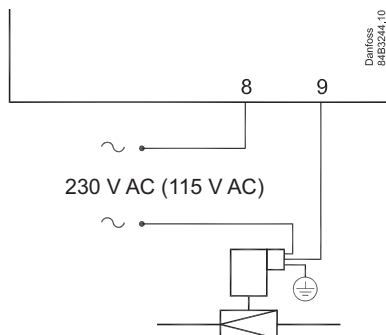

230 V or 115 V AC coil

AKS 32R info

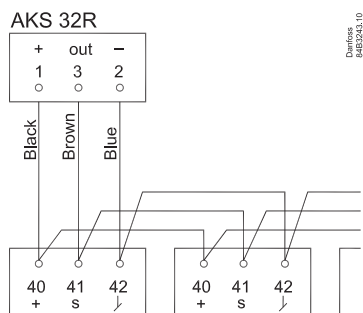

The signal from one pressure transmitter can be received by up to 10 controllers. There must not be a significant pressure drop from the pressure transmitter's position in the suction line to the individual evaporators.

Coordinated defrost via cable connections

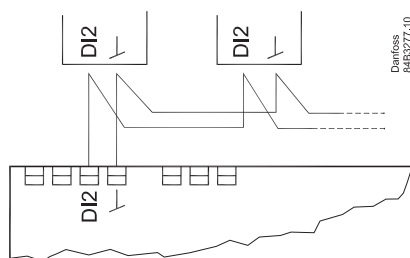

Max. 10

The following controllers can be connected in this way:
EKC 204A, AK-CC 210, AK-CC 250, AK-CC 450, AK-CC 550 and AK-CC55.

Refrigeration is resumed at the same time when all controllers have terminated defrost.

External display AK-UI55

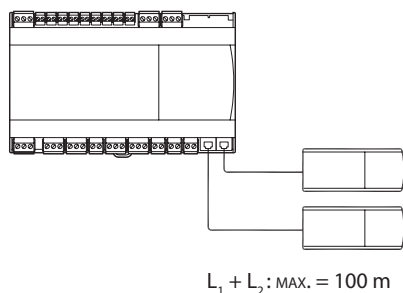

Display
084B4075 / 084B4076 / 084B4077

Cable 3 m: 084B4078
Cable 6 m: 084B4079

$L_1 + L_2$: MAX. = 100 m

Connections

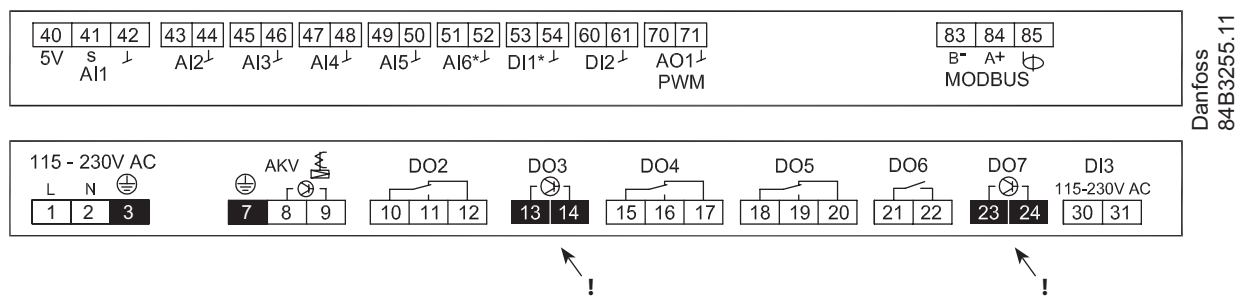

Overview of outputs and applications

Application	DO1	DO2	DO3	DO4	DO5	DO6	DO7	AO1	AI1	AI2	AI3	AI4	AI5	AI6	AI7/DI1	DI2	DI3
1																	
2																	
3																	
4																	
5																	

See also wiring diagrams earlier in the Installation Guide.

● = Optional

AI1

Pressure transmitter

AKS 32R

Connect to terminal 40, 41 and 42.

(Use cable 060G1034: Black=40, Brown=41, Blue=42)

The signal from one pressure transmitter can be received by up to 10 controllers. But only if there are no significant pressure drops between the evaporators to be controlled. See drawing on page 4.

AI2 - AI7

Primarily for temperature inputs

S2

Pt 1000 ohm sensor AKS11, placed at the evaporator outlet
S4, S5

Pt 1000 AKS11, PTC 1000 EKS111, NTC5K EKS211 or NTC10K EKS221 sensor. All have to be of the same type.

S4, discharge air sensor, placed in the cold air after the evaporator

S5, defrost sensor, placed in the evaporator

RH%, 0-10 V signal input from Humidity sensor

(If the DI1 input is used for a temperature measurement, it will appear as AI7.)

DI1

Digital input signal.

The defined function is active when the input is short-circuited or opened, depending on the function defined in o02.

DI2

Digital input signal.

The defined function is active when the input is short-circuited or opened, depending on the function defined in o37.

AO1

Analogue output signal

Analogue 0-10 V (currently not used)

Pulse width modulated signal

Can be used for fast control of rail heat via an external power solid state relay.

MODBUS

For data communication.

Terminal 83 = B-

Terminal 84 = A+

Terminal 85 = screen

It is important that the installation of the data communication cable is performed correctly.

See separate literature no. RC8AC902

Supply voltage

230 V AC or 115 V AC

DO1

AKV valve section A

Connection of expansion valve type AKV, AKVA, AKVH or AKVP. The coil must be a **230 V or 115 V AC coil**.

DO2

Alarm

There is a connection between terminal 10 and 12 in alarm situations and when the controller is without power.

Rail heat

There is connection between terminal 10 and 11 when the function is on.

DO3 (Solid State Relay)

Rail heat, AKV valve section B

There is connection between terminal 13 and 14 when the function must be active.

The coil must be a 230 V or 115 V AC coil. Max. 0.5 A.

DO4

Defrost section A, Rail heat, Humidity

There is connection between terminal 15 and 16 when the function is on.

DO5

Light

There is connection between terminal 18 and 20 when the function must be active.

DO6

Fan

There is connection between terminal 21 and 22 when the fan is on.

DO7 (Solid State Relay)

Defrost section B, AKV valve section C, Heat function

There is connection between terminal 23 and 24 when the function is on.

The coil must be a 230 V or 115 V AC coil. Max. 0.5 A.

DI3

Digital input signal.

The signal must have a voltage of 0 / 230 V AC (115 V AC)

The function is defined in o84.

Display (RJ12 plug)

If external readings/operation of the controller is required, a display can be connected. If there is no display on the front, two external displays can be connected.

For one display the max. cable length is 100 m.

For two displays the sum of the two cable lengths must not exceed 100 m.

Electric noise

Cables for sensors, low voltage DI inputs and data communication **must** be kept separate from other electric cables:

- Use separate cable trays
- Keep a distance between cables of at least 10 cm
- Long cables at the low voltage DI input should be avoided

Installation considerations

Accidental damage, poor installation, or site conditions, can give rise to malfunctions of the control system, and ultimately lead to a plant breakdown.

Every possible safeguard is incorporated into our products to prevent this. However, a wrong installation could still present problems. Electronic controls are no substitute for normal, good engineering practice.

Danfoss will not be responsible for any goods, or plant components, damaged as a result of the above defects. It is the installer's responsibility to check the installation thoroughly, and to fit the necessary safety devices.

Special reference is made to the necessity of signals to the controller when the compressor is stopped and to the need of liquid receivers before the compressors.

Your local Danfoss agent will be pleased to assist with further advice, etc.

Operation with setting display

Display AK-UI 55 Set

The values will be shown with three digits, and with a setting you can determine whether the temperature is to be shown in °C or in °F.

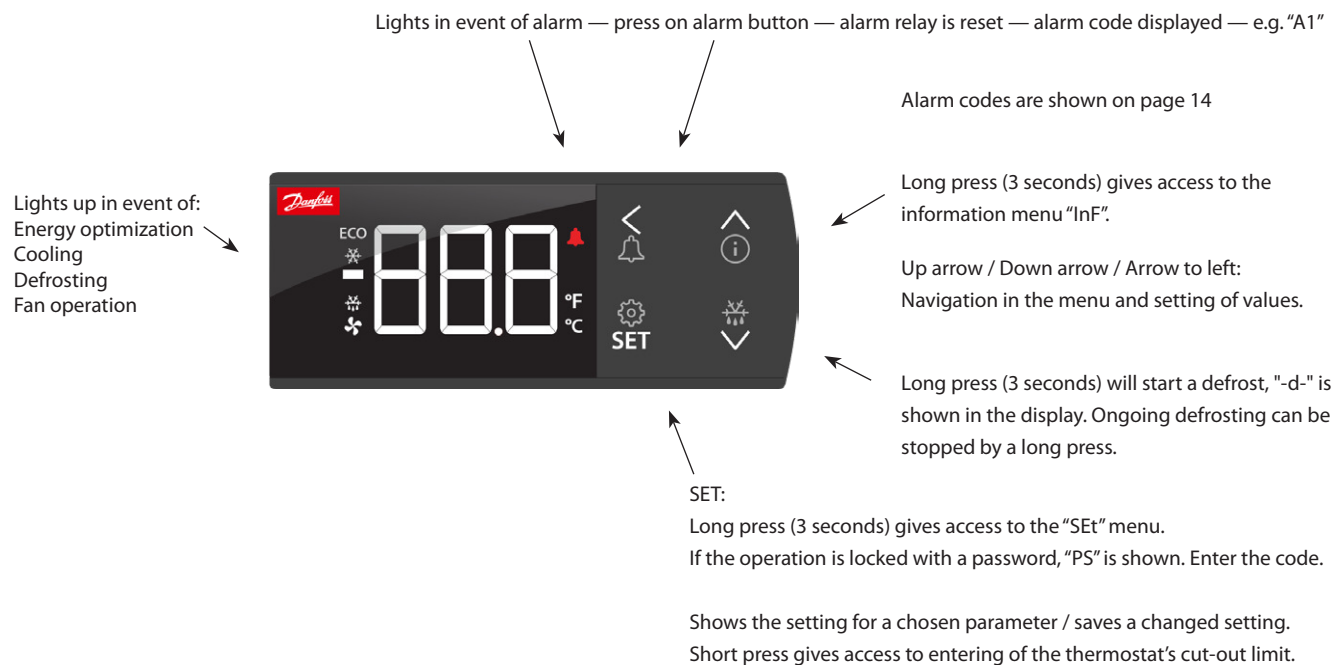

The display can give the following messages:

-d-	Defrost is in progress
Err	The temperature cannot be displayed due to a sensor error
Err	The display cannot load data from the controller. Disconnect and then reconnect the display
ALA	The alarm button is activated. The first alarm code is then shown
---	At top position of the menu or when max. value has been reached, the three dashes are shown in the top of the display
---	At bottom position of menu or when min. value has been reached, the three dashes are shown in the bottom of the display
Loc	The configuration is locked. Unlock by pressing (for 3 seconds) on the 'up arrow' and 'down arrow' simultaneously
UnL	The configuration is unlocked
---	The parameter has reached min. or max. limit
PS	A password is required for access to the menu
Fan	Appliance cleaning has been initiated. The fans are running
OFF	Appliance cleaning is activated and the appliance can now be cleaned
OFF	The main switch is set to Off
SEr	The main switch is set to service / manual operation
CO ₂	Flashes: Will display in event of a refrigerant leakage alarm, but only if the refrigerant is set up for CO ₂

Factory setting

If you need to return to the factory-set values, do the following:

- Cut off the supply voltage to the controller
- Keep up "∧" and down "∨" arrow buttons depressed at the same time as you reconnect the supply voltage
- When FAC is shown in the display, select "yes".

Parameter grouping at display operation

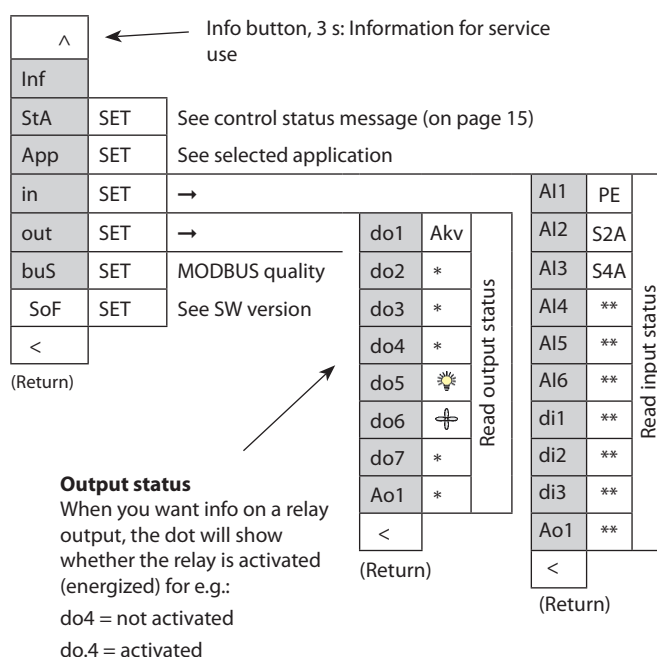
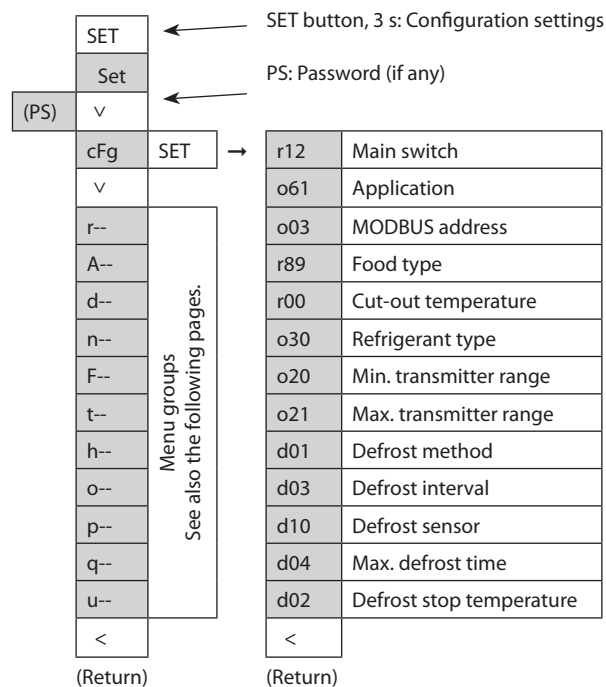

Output status
When you want info on a relay output, the dot will show whether the relay is activated (energized) for e.g.:

- do4 = not activated
- do.4 = activated

*) The output's function. (Determined at configuration). The DOs and AOs can also be forced controlled from this menu, when r12 Main switch has been set in position "service". Forced control of a function can also be performed in codes q11 to q27.

**) The input's function. (Determined at configuration).

Get a good start

With the following procedure you can start regulation very quickly:

- Open parameter r12 and stop the regulation (in a new and not previously set unit, r12 will already be set to 0 which means stopped regulation.)
- Select application based on the wiring diagrams on pages 2-3
- Open parameter o61 and set the application number
- For network. Set the address in o03
- Then select a set of presets from the "Food type" help table
- Open parameter r89 and set the number for the array of presets. The few selected settings will now be transferred to the menu
- Set the desired cut-out temperature r00
- Select refrigerant via parameter o30
- Set the pressure transmitter min. and max. range via parameter o20 and o21.
- Set the desired defrost method in d01
- Set the interval time between defrost starts in d03
- Set the desired defrost sensor in d10
- Set the maximum defrost time in d04
- Set the defrost stop temperature in d02
- Open parameter r12 and start the regulation
- Go through the parameter list and change the factory values where needed.
- Get the controller up and running on network:
 - MODBUS: Activate scan function in system unit
 - If another data communication card is used in the controller:
 - Lon RS485: Activate the function o04

Food type

Setting of presets (r89). After setting 1-5, setting is returned to 0.	1	2	3	4	5
Food type =	Vegetables	Milk	Meat/fish	Frozen food	Ice cream
Temperature (r00)	8 °C	0 °C	-2 °C	-20 °C	-24 °C
Max. temp. setting (r02)	10 °C	4 °C	2 °C	-16 °C	-20 °C
Min. temp. setting (r03)	4 °C	-4 °C	-6 °C	-24 °C	-28 °C
Upper alarm limit (A13)	14 °C	8 °C	8 °C	-15 °C	-15 °C
Lower alarm limit (A14)	0 °C	-5 °C	-5 °C	-30 °C	-30 °C
Upper alarm limit for S6 (A22)	14 °C	8 °C	8 °C	-15 °C	-15 °C
Lower alarm limit for S6 (A23)	0 °C	-5 °C	-5 °C	-30 °C	-30 °C

Can only be set when r12=0.

Menu survey

Menu set via display

SW = 2.0x

Parameter			Wiring diagram pages 2 -3					Min. value	Max. value	Factory setting	Actual setting
Function	R-W	Code	1	2	3	4	5				
Normal operation											
Temperature (setpoint)	0-0	r00	1	1	1	1	1	"r03"	"r02"	2	
Thermostat											
Differential	1-2	r01	1	1	1	1	1	0.1 K	20 K	2	
Max. limitation of setpoint setting	0-2	r02	1	1	1	1	1	"r03"	50 °C	50	
Min. limitation of setpoint setting	0-2	r03	1	1	1	1	1	-50 °C	"r02"	-50	
Temperature unit (°C/°F)	1-2	r05	1	1	1	1	1	0/°C	1/F	0/°C	
Correction of the signal from S4	1-2	r09	1	1	1	1	1	-10 K	10 K	0	
Manual service, stop regulation, start regulation (-1, 0, 1)	0-2	r12	1	1	1	1	1	-1	1	0	
Displacement of reference during night operation	1-2	r13	1	1	1	1	1	-50 K	50 K	0	
Define thermostat function 1=ON/OFF, 2=Modulating, ON/OFF Common	1-2	r14	1	1	1	1	1	1	3	1	
Time between melt periods	1-2	r16	1	1	1	1	1	0 hrs	10 hrs	1	
Duration of melt periods	1-2	r17	1	1	1	1	1	0 min.	30 min.	5	
Temperature setting for thermostat band 2 . As differential use r01	0-2	r21	1	1	1	1	1	-50 °C	50 °C	2	
Heat function Neutral zone between refrigeration and heat function	1-2	r62				1		0 K	50 K	5	
Time delay at switch between refrigeration and heat function	1-2	r63				1		0 min.	240 min.	240	
Food type: use settings listed in table	1-2**	r89	1	1	1	1	1	0	5	0	
Min. limit for S4 temperature	1-2	r98	1	1	1	1	1	-50 °C	50 °C	-50	
Select temperature signal for common thermostat (only if r14=3) 1=air temperature section A, 2=median of all thermostat sensors, 3= maximum of all thermostat sensors	1-2*	r99		1	1	1	1	1	3	1	
Alarms											
Delay for temperature alarm	1-2	A03	1	1	1	1	1	0 min.	240 min.	30	
Delay for door alarm	1-2	A04	1	1	1	1	1	0 min.	240 min.	60	
Delay for temperature alarm after defrost	1-2	A12	1	1	1	1	1	0 min.	240 min.	90	
High alarm limit for thermostat 1	1-2	A13	1	1	1	1	1	-50 °C	50 °C	8	
Low alarm limit for thermostat 1	1-2	A14	1	1	1	1	1	-50 °C	50 °C	-30	
High alarm limit for thermostat 2	1-2	A20	1	1	1	1	1	-50 °C	50 °C	8	
Low alarm limit for thermostat 2	1-2	A21	1	1	1	1	1	-50 °C	50 °C	-30	
Alarm time delay or signal on the DI1 input	1-2	A27	1			1		0 min.	240 min.	30	
Alarm time delay or signal on the DI2 input	1-2	A28	1	1	1	1	1	0 min.	240 min.	30	
Defrost											
Defrost method: 0=No, 1= EL, 4=air	1-3	d01	1	1	1	1	1	0/No	4/Air	1/EL	
Defrost stop temperature	1-2	d02	1	1	1	1	1	0 °C	50 °C	6	
Interval between defrost starts	1-2	d03	1	1	1	1	1	0 hrs/Off	240 hrs	8	
Max. defrost duration	1-2	d04	1	1	1	1	1	0 min.	360 min.	45	
Displacement of time on cut-in of defrost at start-up	1-2	d05	1	1	1	1	1	0 min.	240 min.	0	
Drip off time	1-2	d06	1	1	1	1	1	0 min.	60 min.	0	
Delay for fan start after defrost	1-2	d07	1	1	1	1	1	0 min.	60 min.	0	

R-W

If the operation is limited by a setting of one or more passwords, reading and setting the parameter will be limited to:

R: This setting can be seen with password no. _ or higher.

W: This setting can be performed with password no. _ or higher (3 is the highest level).

*) In order to change this parameter the regulation must be stopped via the parameter r12 Main switch = OFF.

***) In order to change this parameter the parameter r12 Main switch must be set in position "SEr" allowing manual control of outputs.

Multi Coil - continued	R-W	Code	1	2	3	4	5	Min.	Max.	Fac.	Actual
Fan start temperature	1-2	d08	1	1	1	1	1	-50 °C	10 °C	-5	
Fan cut-in during defrost 0: Stopped 1: Running 2: Running during pump down and defrost 3: Running but stops at the temperature set in d41	1-2	d09	1	1	1	1	1	0	3	1	
Defrost sensor: 0 =Stop on time, 1=S5, 2=S4	1-2	d10	1	1	1	1	1	0	2	0	
Pump down delay	1-2	d16	1	1	1	1	1	0 min.	60 min.	0	
Max. aggregate refrigeration time between two defrosts	1-2	d18	1	1	1	1	1	0 hrs	240 hrs	0/OFF	
Rail heat during defrost 0=off. 1=on. 2=Pulsating	1-2	d27	1	1	1	1	1	0	2	1	
Max. duration of -d- in display	1-2	d40	1	1	1	1	1	5 min.	240 min.	30 min.	
Temperature limit for fan stop during defrost when d09 is set to 3	1-2	d41	1	1	1	1	1	-20 °C	20 °C	0	
Injection control function											
Max. value of superheat reference	1-2	n09	1	1	1	1	1	"n10"	20 °C	12	
Min. value of superheat reference	1-2	n10	1	1	1	1	1	2 °C	"n09"	3	
MOP temperature. Off if MOP temp. = 15.0 °C	1-2	n11	1	1	1	1	1	-50 °C	15 °C	15	
Cycle time of AKV pulsation Only for trained personnel	1-2*	n13	1	1	1	1	1	3 sec	6 sec	6	
Fan											
Fan stop temperature (S5)	1-2	F04	1	1	1	1	1	-50 °C	50 °C	50	
Pulse operation on fans: 0=No pulse operation, 1=At thermostat cut-outs only, 2= Only at thermostat cut-outs during night operation	1-2	F05	1	1	1	1	1	0	2	0	
Cycle time for fan pulsation (on-time + off-time)	1-2	F06	1	1	1	1	1	1 min.	30 min.	5	
On-time in % of cycle time	1-2	F07	1	1	1	1	1	0 %	100 %	100	
Real time clock											
Defrost start via defrost schedule: 0/off=no. 1/on=yes	1-2	t00	1	1	1	1	1	0/off	1/on	0/off	
Six start times for defrost. Setting of hours. 0=OFF	1-2	t01 - t06	1	1	1	1	1	0 hrs	23 hrs	0	
Six start times for defrost. Setting of minutes. 0=OFF	1-2	t11 - t16	1	1	1	1	1	0 min.	59 min.	0	
Clock - Setting of hours	0-1	t07	1	1	1	1	1	0 hrs	23 hrs	0	
Clock - Setting of minutes	0-1	t08	1	1	1	1	1	0 min.	59 min.	0	
Clock - Setting of date	0-1	t45	1	1	1	1	1	1 day	31 days	1	
Clock - Setting of month	0-1	t46	1	1	1	1	1	1 mon.	12 mon.	1	
Clock - Setting of year	0-1	t47	1	1	1	1	1	0 years	99 years	0	
Defrost schedule for Mondays is active at On/1	1-2	t51	1	1	1	1	1	0/Off	1/On	1/On	
Defrost schedule for Tuesdays is active at On/1	1-2	t52	1	1	1	1	1	0/Off	1/On	1/On	
Defrost schedule for Wednesdays is active at On/1	1-2	t53	1	1	1	1	1	0/Off	1/On	1/On	
Defrost schedule for Thursdays is active at On/1	1-2	t54	1	1	1	1	1	0/Off	1/On	1/On	
Defrost schedule for Fridays is active at On/1	1-2	t55	1	1	1	1	1	0/Off	1/On	1/On	
Defrost schedule for Saturdays is active at On/1	1-2	t56	1	1	1	1	1	0/Off	1/On	1/On	
Defrost schedule for Sundays is active at On/1	1-2	t57	1	1	1	1	1	0/Off	1/On	1/On	
Humidity											
Setpoint for cut-in of humidity function	0-2	h23					1	0 %	100 %	70	
Difference for humidity function	1-2	h24					1	1 %	30 %	5	
Alarm limit for high humidity (too damp)	1-2	h25					1	0 %	100 %	100	
Alarm limit for low humidity (too dry)	1-2	h26					1	0 %	100 %	0	
Delay time for a humidity alarm	1-2	h27					1	0 min.	240 min.	60	
Humidity function during defrosting	1-2	h28					1	0/Off	1/On	0/Off	
Setpoint for RH% at input signal on 0 V	1-2*	h29					1	0 %	"h30"	0	
Setpoint for RH% at input signal on 10 V	1-2*	h30					1	"h29"	100 %	100	
Use humidity control	1-2*	h31					1	0/Off	1/On	0/Off	

Multi Coil - continued	R-W	Code	1	2	3	4	5	Min.	Max.	Fac.	Actual
Miscellaneous											
Delay of output signals after power failure	1-2	o01	1	1	1	1	1	0 sec	600 sec	5	
Input signal on DI1. Function: 0=not used. 1=status on DI1. 2=door function with alarm when open. 3=door alarm when open. 4=defrost start (pulse-signal). 5=ext.main switch. 6=night operation. 7=thermostat band changeover (activate r21). 8=alarm function when closed. 9=alarm function when open. 10=Appliance cleaning (pulse signal). 11=forced cooling at hot gas defrost, 12=Open night cover. 14=Refrigeration stopped (forced closing). 15=case shutdown. 16=light. 20=Refrigerant alarm. 21= adaptive liquid control when short-circuited.	1-2*	o02	1			1		0	21	0	
Network address	1-3*	o03	1	1	1	1	1	0	240	0	
On/Off switch (Service Pin message) IMPORTANT! o61 must be set prior to o04 (used at Lon 485)	1-2	o04	1	1	1	1	1	0/Off	1/On	0/Off	
Access code 3 (all settings)	3-3	o05	1	1	1	1	1	0	999	0	
Used sensor type: 0=Pt1000, 1=PTC1000, 2=Ntc5K, 3=Ntc10K. (S2 is not affected. It is always Pt1000 ohms)	1-3*	o06	1	1	1	1	1	0/Pt	3/N10	0/Pt	
Max. hold time after coordinated defrost	1-2	o16	1	1	1	1	1	0 min.	360 min.	20	
Pressure transmitter working range – min. value	1-3*	o20	1	1	1	1	1	-1 bar	5 bar	-1	
Pressure transmitter working range – max. value	1-3*	o21	1	1	1	1	1	6 bar	200 bar	12	
Refrigerant setting: 1=User defined. 3-digits. 2=R22. 3=R134a. 4=R502. 5=R717. 6=R13. 7=R13b1. 8=R23. 9=R500. 10=R503. 11=R114. 12=R142b. 13=User defined. 14=R32. 15=R227. 16=R401A. 17=R507. 18=R402A. 19=R404A. 20=R407C. 21=R407A. 22=R407B. 23=R410A. 24=R170. 25=R290. 26=R600. 27=R600a. 28=R744. 29=R1270. 30=R417A. 31=R422A. 32=R413A. 33=R422D. 34=R427A. 35=R438A. 36=R513A. 37=R407F. 38=R1234ze. 39=R1234yf. 40=R448A. 41=R449A. 42=R452A. 43=R450A. 44=R452B. 45=R454B. 46=R1233zdE. 47=R1234zeZ. 48=R449B. 49=R407H.	1-3*	o30	1	1	1	1	1	0	42	0	
Input signal on DI2. Function: 0=not used. 1=status on DI2. 2=door function with alarm when open. 3=door alarm when open. 4=defrost start (pulse-signal). 5=ext. main switch. 6=night operation. 7=thermostat band changeover (activate r21). 8=alarm function when closed. 9=alarm function when open. 10=Appliance cleaning (pulse signal). 11=forced cooling at hot gas defrost. 12=Open night cover, 13=coordinated defrost. 14=Refrigeration stopped (forced closing). 15=case shutdown. 16=light. 20=Refrigerant alarm. 21= adaptive liquid control when short-circuited.	1-2*	o37	1	1	1	1	1	0	21	0	
Configuration of light function: 1=Light follows day /night operation, 2=Light control via data communication via 'o39', 3=The light is controlled with a door switch on a DI input, 4=As "2", but light switches on and night cover will open if the network cuts out for more than 15 minutes, 5=Light controlled via a DI input.	1-2	o38	1	1	1	1	1	1	5	1	
Activation of light relay (only if o38=2) On=light	1-2	o39	1	1	1	1	1	0/Off	1/On	0/Off	
Rail heat On time during day operations	1-2	o41	1	1	1	1	1	0 %	100 %	100	
Rail heat On time during night operations	1-2	o42	1	1	1	1	1	0 %	100 %	100	
Rail heat cycle time (On time + Off time)	1-2	o43	1	1	1	1	1	1 min.	60 min.	5	
Appliance cleaning. 0=no Appliance cleaning. 1=Fans only. 2=All output Off.	1-2	o46	1	1	1	1	1	0	2	0	
Selection of wiring diagram. See overview on pages 2-3	1-3*	o61	1	1	1	1	1	1	9	1	
Access code 2 (partial access)	2-2	o64	1	1	1	1	1	0	999	0	
Replace the controller's factory settings with the present settings	3-3*	o67	1	1	1	1	1	0/Off	1/On	0/Off	
Input signal on DI3. Function: (high voltage input) 0=not used. 1=status on DI2. 2=door function with alarm when open. 3=door alarm when open. 4=defrost start (pulse-signal). 5=ext. main switch 6=night operation. 7=thermostat band changeover (activate r21). 8=Not used. 9=Not used. 10=Appliance cleaning (pulse signal). 11=forced cooling at hot gas defrost. 12=Open night cover. 13=Not used. 14=Refrigeration stopped (forced closing). 15=case shutdown. 16=light. 20=Refrigerant alarm. 21= adaptive liquid control when short-circuited.	1-2*	o84	1	1	1	1	1	0	21	0	
Rail heat control 0=not used, 1=pulse control with timer function (o41 and o42), 2=pulse control with dew point function A	1-2	o85	1	1	1	1	1	0	2	0	

Multi Coil - continued	R-W	Code	1	2	3	4	5	Min.	Max.	Fac.	Actual
Dew point value where the rail heat is minimum	1-2	o86	1	1	1	1	1	-10 °C	""o87	8	
Dew point value where the rail heat is 100% on	1-2	o87	1	1	1	1	1	"o86"	50 °C	17	
Lowest permitted rail heat effect in %	1-2	o88	1	1	1	1	1	0 %	100 %	30	
Time delay from "open door" refrigeration is started	1-2	o89	1	1	1	1	1	0 min.	240 min.	30	
Fan operation at stopped cooling (forced closing): 0= Stopped (defrost allowed) 1= Running (defrost allowed) 2= Stopped (defrost not allowed) 3= Running (defrost not allowed)	1-2	o90	1	1	1	1	1	0	3	1	
Display of temperature 1= Thermostat air 2= Average all 3= Maximum all	1-2	o97	1	1	1	1	1	1	3	1	
Light and night blinds defined: 0: Light is switched off and night blind is opened when the main switch is off 1: Light and night blind is independent of main switch	1-2	o98	1	1		1	1	0	1	0	
Configuration of alarm relay: The alarm relay will be activated by an alarm in one or more of the following priorities. Setting: 0 = The relay is not activated by alarms 1 = Only high priority alarms 2 = High and medium priority alarms 3 = High, medium and low priority alarms	1-2	P41	1	1	1	1	1	0	3	2	
Cycle time for rail heat at PWM on AO1	1-2	P82	1	1	1	1	1	4 sec	60 sec	10	
User defined refrigerant 3-digit Rfg. factor K1	1-3*	P83	1	1	1	1	1	-999	999	300	
User defined refrigerant 3-digit Rfg. factor K2	1-3*	P84	1	1	1	1	1	-999	999	300	
User defined refrigerant 3-digit Rfg. factor K3	1-3*	P85	1	1	1	1	1	-999	999	300	
Max. limitation of the superheat reference when regulated with liquid-filled evaporator	1-2	P86	1	1	1	1	1	"P87"	20°C	3	
Min. limitation of the superheat reference when regulated with liquid-filled evaporator	1-2	P87	1	1	1	1	1	0°C	"P86"	1	
Access code 1 (simple access)	1-1	P88	1	1	1	1	1	0	999	0	
Locking the display control. 0/Off=operation. 1/On=locked	1-2	P89	1	1	1	1	1	0/Off	1/On	0/Off	
Configuration of analogue output AO1: 0=not used. 1=rail heat PWM	1-3*	q09	1	1	1	1	1	0	1	0	
Manual control of output: AKV valve 0-100%	1-2**	q11	1	1	1	1	1	0 %	100 %	0	
Manual control of output: Fan	1-2**	q13	1	1	1	1	1	0/Off	1/On	0/Off	
Manual control of output: Defrost A	1-2**	q14	1	1			1	0/Off	1/On	0/Off	
Manual control of output: Rail heat	1-2**	q15	1	1	1			0/Off	1/On	0/Off	
Manual control of output: Alarm	1-2**	q16	1		1	1	1	0/Off	1/On	0/Off	
Manual control of output: Light	1-2**	q17	1	1	1	1	1	0/Off	1/On	0/Off	
Manual control of output: Defrost B	1-2**	q22		1			1	0/Off	1/On	0/Off	
Manual control of output: Heating element	1-2**	q23				1		0/Off	1/On	0/Off	
Manual control of output: Humidity	1-2**	q26				1		0/Off	1/On	0/Off	
Manual control of output: Rail heat PWM	1-2**	q27	1	1	1	1	1	0 %	100 %	0	
Define which food temperature measurement to display in U72: 1=Air temperature section A 2=Average air temperature of all sections 3= The highest air temperature of all sections	1-2*	q39	1	1	1	1	1	1	3	2	
AKV OD % B	1-2**	q41		1	1	1	1	0 %	100 %	0	
AKV OD % C	1-2**	q42			1			0 %	100 %	0	
Correction of signal from S4B	1-2	q43			1	1		-10 K	10 K	0	
Correction of signal from S4C	1-2	q44			1	1	1	-10 K	10 K	0	
Service											
Control mode section A	0-0	u00	1	1	1	1	1				
Temperature measured with S5 sensor	0-0	u09	1	1	1	1	1				
Status on DI1 input. on/1=closed	0-0	u10	1				1				
Actual defrost time (minutes)	0-0	u11	1	1	1	1	1				
Status on night operation (on or off) 1=on	0-0	u13	1	1	1	1	1				
Temperature measured with S4 sensor	0-0	u16	1	1	1	1	1				
Thermostat temperature	0-0	u17	1	1	1	1	1				

Multi Coil - continued	R-W	Code	1	2	3	4	5
Runtime of thermostat (cooling time) in minutes	0-0	u18	1	1	1	1	1
Temperature of S2 evaporator outlet temp.	0-0	u20	1	1	1	1	1
Superheat across evaporator	0-0	u21	1	1	1	1	1
Reference of superheat control	0-0	u22	1	1	1	1	1
Opening degree of AKV valve	0-0	u23	1	1	1	1	1
Evaporating pressure Po (relative)	0-0	u25	1	1	1	1	1
Evaporator temperature To (Calculated)	0-0	u26	1	1	1	1	1
Status on DI2 input. on/1=closed	0-0	u37	1	1	1	1	1
Readout display 1 value	0-0	u56	1	1	1	1	1
Readout of alarm air temp. Section A	0-0	u57	1	1	1	1	1
Status on relay for fan	0-0	u59	1	1	1	1	1
Status on relay for defrost	0-0	u60	1	1			1
Status on relay for rail heat	0-0	u61	1	1	1		
Status on relay for alarm	0-0	u62	1		1	1	1
Status on relay for light	0-0	u63	1	1	1	1	1
Temperature measured with S5B sensor	0-0	u75		1			1
Status on relay for defrost B	0-0	u83		1			1
Status on relay for heat function	0-0	u84				1	
Readout of the actual rail heat effect via relay	0-0	u85	1	1	1	1	1
1: Thermostat 1 operating, 2: Thermostat 2 operating	0-0	u86	1	1	1	1	1
Status on high voltage input DI3	0-0	u87	1	1	1	1	1
Readout of thermostat band in use	0-0	u90	1	1	1	1	1
Readout of thermostat's actual cut-out value	0-0	u91	1	1	1	1	1
Readout of alarm air temp. Section B	0-0	U34		1	1	1	1
Readout of display 2 value	0-0	U35		1	1	1	1
Readout of signal quality for MODBUS communication	0-0	U45	1	1	1	1	1
Readout of measured humidity in %	0-0	U57				1	
Status of relay for humidity	0-0	U58				1	
Readout of rail heat effect via AO1 in %	0-0	U59	1	1	1	1	1
Readout of measured food temperature (defined in q39)	0-0	U72	1	1	1	1	1
Readout of measured defrost stop temperature (defined in d10)	0-0	U73	1	1	1	1	1
Control mode section B	0-0	U74		1	1	1	1
Actual defrost time (minutes) section B	0-0	U75		1	1	1	1
Actual S4 temperature section B	0-0	U76		1	1	1	1
Thermostat temperature section B	0-0	U77		1	1	1	1
Runtime of thermostat (cooling time) in minutes section B	0-0	U78		1	1	1	1
Temperature of evaporator outlet temp. section B	0-0	U79		1	1	1	1
Superheat across evaporator section B	0-0	U80		1	1	1	1
Reference of superheat control section B	0-0	U81		1	1	1	1
Opening degree of AKV valve section B	0-0	U82		1	1	1	1
Control mode section C	0-0	U83			1		
Actual defrost time (minutes) section C	0-0	U84			1		
Actual S4 temperature section C	0-0	U85			1		
Thermostat temperature section C	0-0	U86			1		
Runtime of thermostat (cooling time) in minutes section C	0-0	U87			1		
Temperature of evaporator outlet temp. section C	0-0	U88			1		
Superheat across evaporator section C	0-0	U89			1		
Reference of superheat control section C	0-0	U90			1		
Opening degree of AKV valve section C	0-0	U91			1		
Readout of alarm air temp. section C	0-0	U92			1		
Defrost stop temperature section B	0-0	U93		1	1	1	1
Defrost stop temperature section C	0-0	U94			1		

Factory setting

If you need to return to the factory-set values, do the following:

- Cut off the supply voltage to the controller
- Keep up "▲" and down "▼" buttons depressed at the same time as you reconnect the supply voltage
- When FAC is shown in the display, select "yes".

Fault message		
<p>In an error situation the alarm LED on the front will be on and the alarm relay will be activated (depending on priority). If you push the alarm button for 3 seconds you can see the alarm report in the display. (Alarm priorities can be changed. See the User Guide.) Here are the messages that may appear:</p>		
Code / Alarm text via data communication	Description	Alarm relay groups (P41)
A1/--- High t.alarm	High temperature alarm	1
A2/--- Low t. alarm	Low temperature alarm	2
A4/--- Door alarm	Door alarm	4
A5/--- Max. hold time	The "o16" function is activated during a coordinated defrost	5
A11/--- No Rfg. sel.	No refrigerant selected	7
A15/--- DI1 alarm	DI1 alarm	4
A16/--- DI2 alarm	DI2 alarm	4
A45/--- Standby mode	Standby position (stopped refrigeration via r12 or DI input)	8
A59/--- Case clean	Appliance cleaning. Signal from DI input	8
A70/--- HighTemp.B	Temperature alarm section B	1
A71/--- Low Temp. B	Temperature alarm section B	2
AA2/ ---Refrig Leak	A refrigerant leak detection signal is received	9
AA3/--- CO2 alarm	A refrigerant leak detection signal is received and the selected refrigerant is CO2	9
a02/--- HighHumidity	Too high humidity	10
a03/--- Low Humidity	Too low humidity	10
a04/--- Wrong IO cfg	The configuration of inputs and outputs is incorrect	6
--- Max. Def.Time (A,B,C)	Defrost stopped based on time instead of, as wanted, on temperature. Section A / B / C	5
E1/--- Ctrl. error	Faults in the controller	6
E6/--- RTC error	Check clock	6
E20/--- Pe error	Error on pressure transmitter Pe	3
E24/--- S2 error	Error on S2 sensor	3
E25/--- S3 error	Error on S3 sensor	3
E26/--- S4 error	Error on S4 sensor	3
E27/--- S5 error	Error on S5 sensor	3
E37/--- S5 error B	Error on S5B sensor	3
E59/---RH input err	Missing signal from the humidity meter	3
E60/--- S4 error B	Error on S4B sensor	3
E61/--- S4 error C	Error on S4C sensor	3
E62/--- S2 error B	Error on S2B sensor	3
E63/--- S2 error C	Error on S2C sensor	3
<p>Data communication The importance of individual alarms can be defined with a setting. The setting must be carried out in the group "Alarm destinations".</p>		

Operating status		(Measurement)
The controller goes through some regulating situations where it is just waiting for the next sequence of the regulation. To make these “why is nothing happening” situations visible, you can see an operating status on the display. Push the info button for 3 seconds to see status. If there is a status code, it will be shown on the display. The individual status codes have the following meanings:		Ctrl. state: (Shown in all menu displays)
Normal regulation	S0	0
Waiting for end of the coordinated defrost	S1	1
The evaporator drips off and waits for the time to run out	S4	4
Refrigeration stopped by main switch. Either with r12 or a DI-input	S10	10
Refrigeration stopped by thermostat	S11	11
The refrigeration is stopped due to too low S4 temperature	S12	12
Defrost sequence. Defrost in progress	S14	14
Defrost sequence. Fan delay — water attaches to the evaporator	S15	15
Refrigeration stopped due to open ON input or stopped regulation	S16	16
Door is open. DI input is open	S17	17
Melt function in progress. Refrigeration is interrupted	S18	18
Modulating thermostat control	S19	19
Emergency cooling *)	S20	20
Adaptive control of superheat	S23	23
Start-up phase 1. Signal reliability from sensors is controlled	S24	24
Manual control of outputs	S25	25
No refrigerant selected	S26	26
Appliance cleaning	S29	29
Forced cooling	S30	30
Delay on outputs during start-up	S32	32
Heat function is active	S33	33
Case shutdown	S45	45
Operation with adaptive liquid control	S48	48
<i>Other displays:</i>		
Defrost in progress / first cooling after the defrost where the temperature is still above the thermostat band.	-d-	
Password required. Set password	PS	
Regulation is stopped via main switch or case cleaning	OFF	
The main switch is set to service/manual operation	SEr	

*) Emergency cooling will take effect when there is lack of signal from a defined S3 or S4 sensor or signal from the pressure transmitter is outside signal range. The regulation will continue with a registered average cut-in frequency. There are two registered values – one for day operation and one for night operation.

Additional information:
User Guide: BC308437742037en-000101

