



# Installation guide

## Mini Electric expansion valve Type ETS 5M

English    Deutsch    French    español    汉语

034R9819

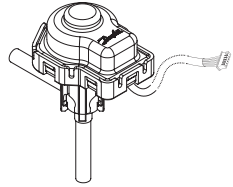
034R9819

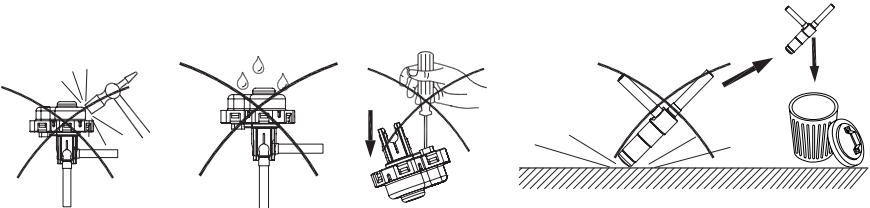
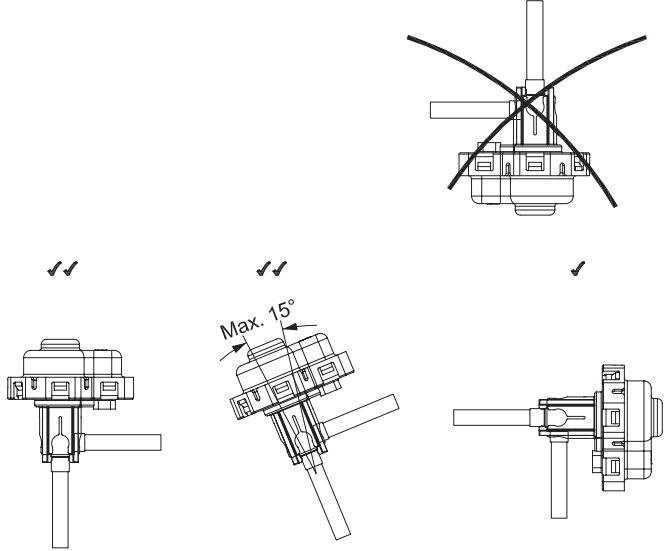
<p>Refrigerants Kältemittel Fluides Refrigerantes 适用的冷媒 <b>R410A, R32</b></p>	<p>Refrigerant temperature (JB/T 10212-2016) Kältemitteltemperaturbereich (JB/T 10212-2016) Température du fluide (JB/T 10212-2016) Temperatura líquida (JB/T 10212-2016) 流体温度 (JB/T 10212-2016) <b>t<sub>Min.</sub>: -30 °C / -22 °F, t<sub>Max.</sub>: 70 °C / 158 °F</b></p>		<p>Max. working pressure Max. Betriebsdruck Pression de service max Máxima presión de trabajo 最大工作压力 <b>PS / MWP: 4.55 MPa / 45.5 barg / 660 psig</b></p>	
<p>Allowable ambient temperature (JB/T 10212-2016) Zulässige Umgebungstemperatur Température ambiante admissible Temperatura ambiente permisible 允许的运行温度 <b>-30 °C / -22 °F - 60 °C / 140 °F</b></p>	<p>Stepper motor type Schrittmotortype Type de moteur pas à pas Tipo de motor a pasos 步进电机形式 <b>Unipolar / 单级</b></p>	<p>Nominal voltage Nennspannung Tension nominale Voltaje nominal 名义电压 <b>12 V DC</b></p>	<p>Phase current Phasenstrom Courant de phase Corriente de fase 相电流 <b>240 mA</b></p>	<p>Resistance Widerstand Résistance Resistencia 电阻 <b>50 Ω</b></p>
<p> <b>Warning!</b> Achtung! Attention! Advertencia! <b>警告</b></p>  <p>Do not connect directly to AC / DC power source. Connect valve to appropriate controller / driver only. Do not operate valve while assembling or disassembling.</p> <p>Bitte den ETS 5M nicht direkt mit einer Spannungsquelle (Gleich- oder Wechselstrom) verbinden. Schließen Sie das Ventil nur an geeignete Regler/ Steuergeräte an. Ventil bitte nicht in zerlegtem Zustand ansteuern.</p> <p>Ne pas raccorder directement le moteur à une alimentation AC / DC. Raccorder la vanne au régulateur approprié. Ne pas actionner la vanne pendant le montage ou le démontage.</p> <p>No aplicar tensión directamente a la válvula. Conectar la válvula a un controlador/driver adecuado. No haga funcionar la válvula durante el montaje o desmontaje.</p> <p>请仅将阀门连接于合适的控制器/控制器，勿直接与交流或直流电源连接。 在安装和拆卸阀门时请勿操作电子膨胀阀。</p>			<p><b>1</b> Mounting / Einbau / Montage / Instalación / <b>安装</b></p> 	

**2** Open position / Offene Position /  
Position ouverte / Posición abierta /  
阀开度

Always open valve to overdrive before brazing  
using manual coil.  
Vor dem Löten, das Ventil mit einer Handspule in  
die vollständig geöffnete Position öffnen.  
Avant le brasage, utilisez une bobine manuel pour  
ouvrir la vanne en position complètement ouverte.  
Abra siempre la válvula a tope antes de soldar  
usando una bobina manual  
必须全开焊接！（使用手工线圈）

ETS 5M manual coil: Code no. 034G3803

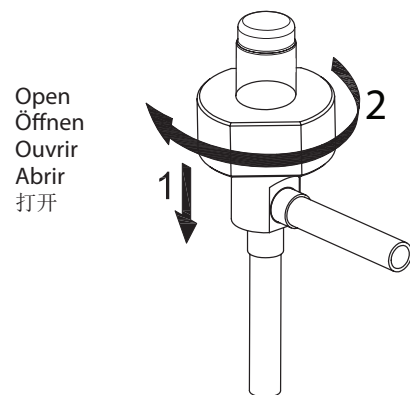

Open  
Öffnen  
Ouvrir  
Abrir  
打开

**3** Brazing / Löten / Soudure /  
Soldadura / 焊接

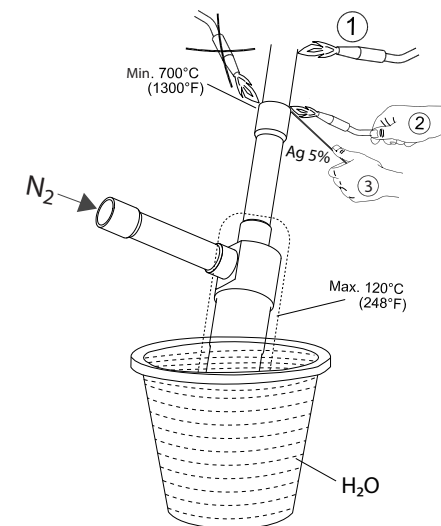
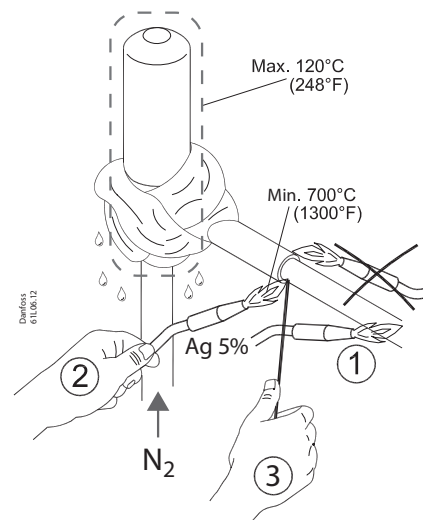

N2 gas from opposite side of soldering point.  
Schutzgas gegenüber der Lötstelle einströmen lassen.  
Refroidissement gaz ci-contre site de point de soudure.  
Corriente de N2 desde el lado opuesto a la soldadura.  
气体冷却对面的焊点（氮气保护）

**4** Assembling / Zusammenbau / Assemblage / Montaje / 安装

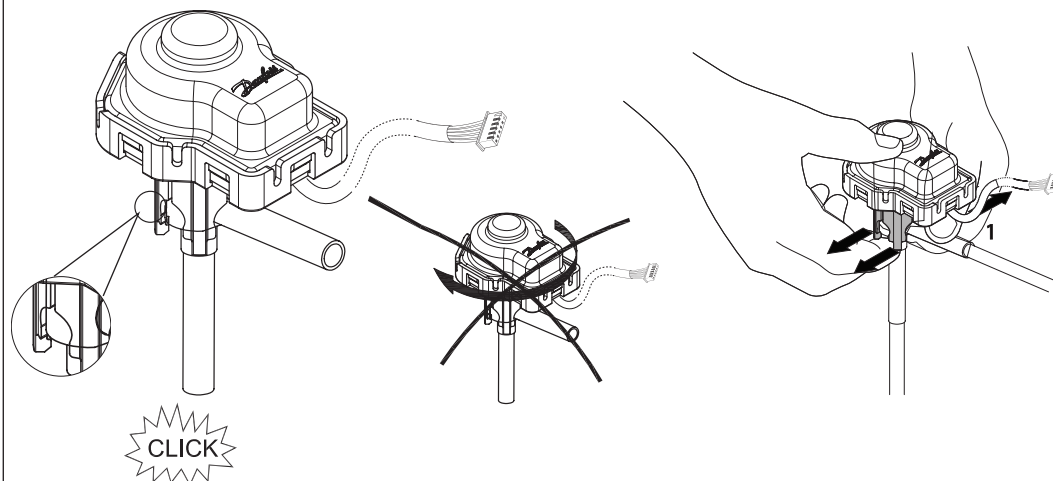

**5** Connection / Anschluss / Raccordement Conexión / 连接

