

Installation guide

Actuator

Type ICAD 600B / 600B-TS / 1200B

UK
CA

027R9001

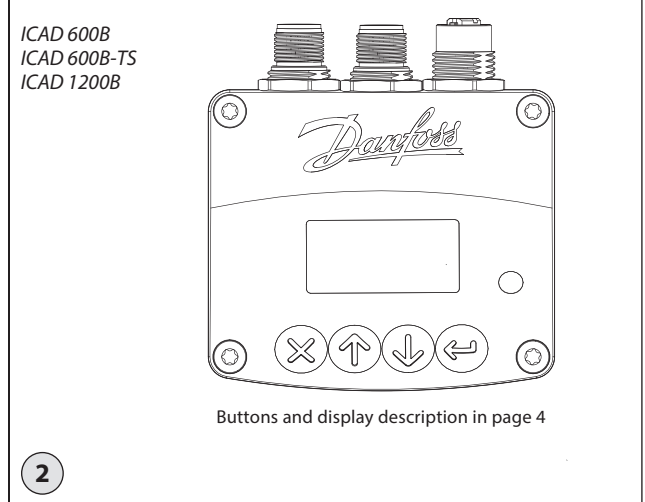
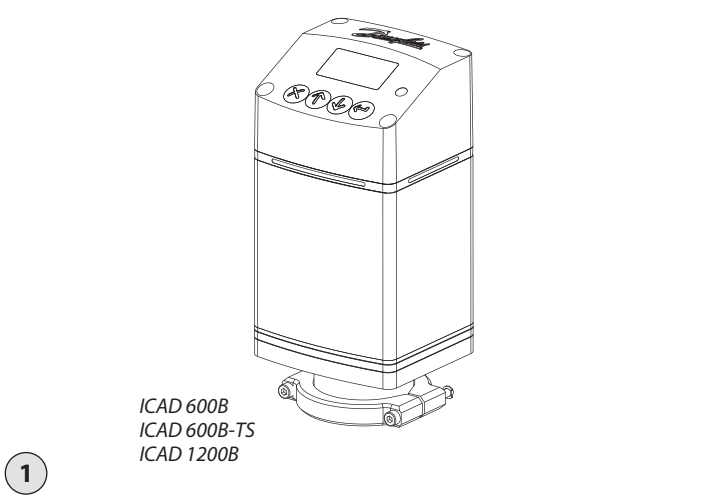

027R9001

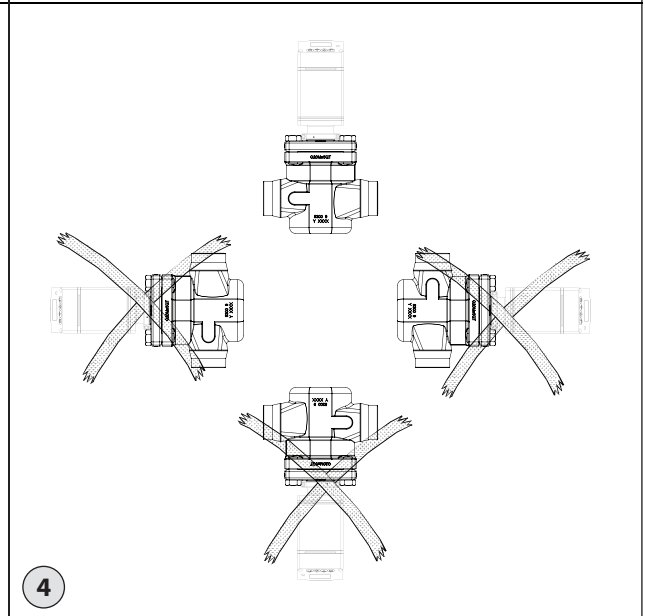
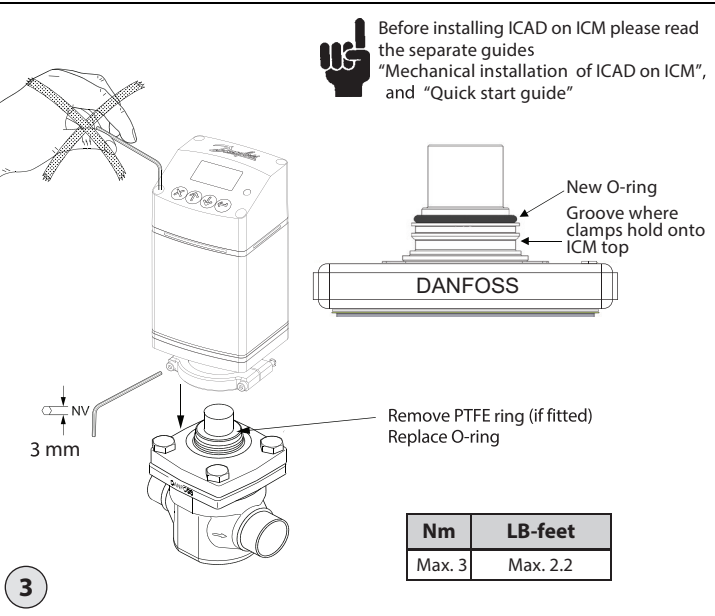

Імпортер: ТОВ з іі "Данфосс ТОВ" 04080, Київ 80, п/с 168, Україна

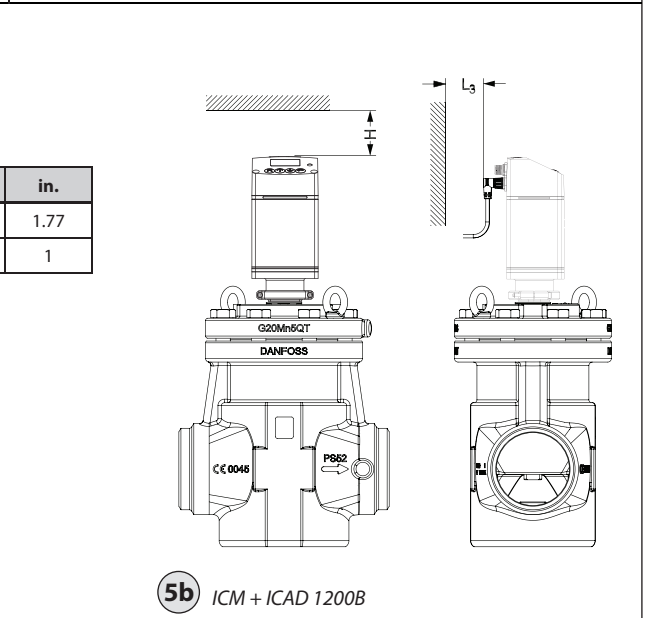
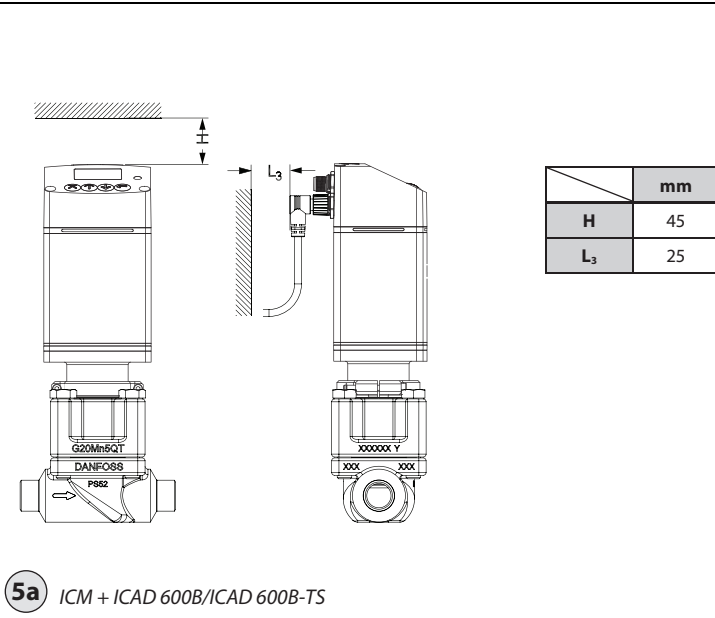

Info for UK customers only : Danfoss Ltd., 22 Wycombe End, HP9 1NB, GB

ICAD 600B / ICAD 600B-TS / ICAD 1200B

Terminal box - not supplied by Danfoss

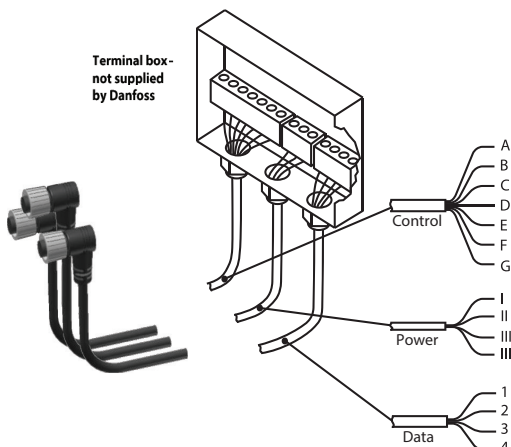

ICAD back



Ref	Color	Description
A	Black	- Common alarm
B	Brown	- ICM fully open
C	Red	- ICM fully closed
D	Orange	- GND ground
E	Yellow	+ 0/4 -20 mA Input
F	Green	+ 0/2-10 V input or digital input for on/off control
G	Blue	+ 0/4 -20 mA Output

Digital output

I	Black	+ Fail safe supply. Battery / UPS* 19 V DC
II	White	+ Supply voltage 24 V DC 2A, or more, per ICAD recommended
III	Brown	- ICAD PSU must be SELV**, >15 W
IIII	Blue	+ UPS Signal of Health - optional depending on ID31: 'UPS supply' set to 'Yes'

RS 485 / Ethernet RS 485 / Ethernet

1	White/Blue	(-) / TX+	Data - (B) / Transmit Pair(+)
2	White/Orange	GND / RX+	Ground / Receiving Pair(+)
3	Blue	(+) / TX-	Data + (A) / Transmit Pair(-)
4	Orange	GND / RX-	Ground / Receiving Pair(-)

*Uninterruptable Power Supply
** The ICAD is a Class III appliance

6

ICAD 600B/1200B - Analog I/O for modulating control

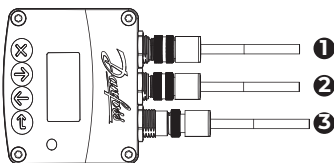

- 1 Control cable
- 2 Power supply cable
- 3 Data cable

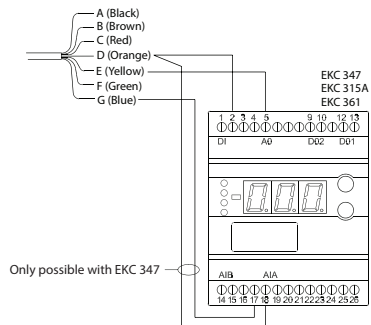
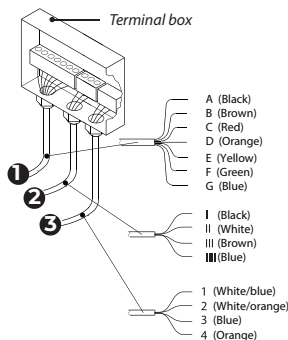

7

ICAD 600B/600B-TS/1200B - Digital I/O for ON/OFF valve operation

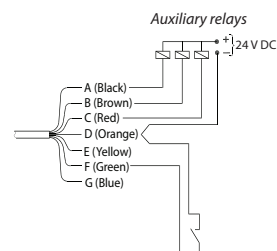
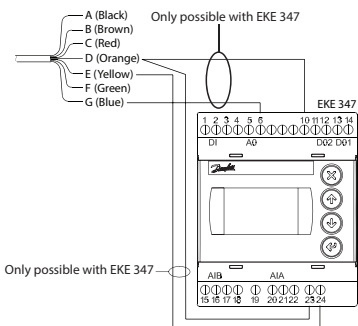

8

Neutral zone/3 points control

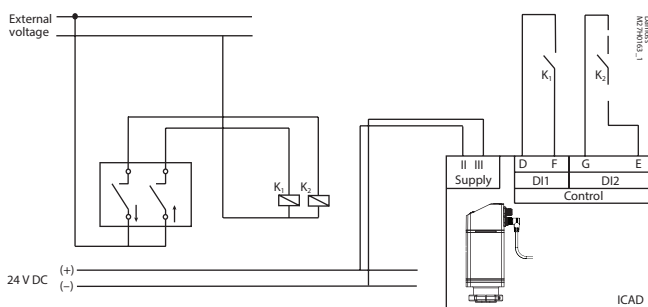

9

ENGLISH

Installation

Do not install ICAD before welding. This apply for electrical as well as for mechanical installation. Please observe that ICAD when connected to 24 V DC, will send out acoustic noise at stand still. This has no influence on the function/ operation of the ICAD.

Use

ICAD 600B, ICAD 600B-TS and ICAD 1200B can be used together with the following Danfoss valves (fig. 1, 5a and 5b).

ICAD 600B	ICAD 600B-TS	ICAD 1200B
ICM 20	ICM TS 20	ICM 40
ICM 25	ICM TS 50	ICM 50
ICM 32	ICM TS 80	ICM 65
		ICM 100
		ICM 125
		ICM 150
		CVE pilot valve

Electrical data

Supply voltage is galvanically isolated from in-/output. ICAD is a Class III product. PSUs connected to ICAD must be SELV<100 VA

For UL compliance:

PSU must be Class 2 NEC
Control type: Operating Control – Type 1 Action
Pollution Degree: 3

Supply voltage

24 V DC (Tolerances; see below table)
Load ICAD 600B, ICAD 600B-TS: 1.2 A
ICAD 1200B: 2.0 A

24 Volt DC ONLY

Please observe cable voltage drop.
Distance between the applied DC transformer and the ICAD terminal box may cause a voltage drop. Cross section of cables and size of DC transformer must be calculated so that the voltage at all time **at the ICAD terminal box***, both during standstill and during operation of ICAD, is within this range:

Prefabricated ICAD cable length Code number	1.5 m 027H0426	3 m 027H0438	10 m 027H0427	15 m 027H0435
Voltage ICAD terminal (600B/1200B) [V DC]	Min. 21	22	23	24
	Max. 26.4			

* Do not measure inside the ICAD itself (value can be checked in ICAD B menu).

Fail safe supply

24 V DC (Tolerances; see table above)
Load ICAD 600B, ICAD 600B-TS: 1.2 A
ICAD 1200B: 2.0 A

Data communication

RS 485: It is important that the installation of the data communication cable is done correctly. For further guidance, see literature No. RC8AC902. Remember termination at the bus termination. Max length of cable: 1200 m with specific cable and limited data rate. Follow RS485 standard.

Insulation from power supply input, metallic part and interface output : 500 V DC. *For input/output connections

Analog Input - Current or Voltage

Current

Input range: 0/4 – 20 mA
Max input range: 0 – 24 mA
Input resistance: 120 Ω + diode voltage 0.7 V DC
Measurement error: <±1.5% of the full scale
Reverse polarity protection: yes
Overcurrent protection: yes

Voltage

Input range: 0/2 – 10 V DC
Max input range: 0 – 12 V DC
Measurement error: <±1.5% of the full scale
Reverse polarity protection: yes

Analog Output

Output range: 0/4 – 20mA
Load: <800 Ω
Output error: <±1.5% of the full scale
Recommended external resistor for Hot application: Rext=800 Ω-load1W power rate

Digital Input - Digital ON/OFF input by means of voltfree contact (Signal/Telecom relays with gold-plated contacts recommended) – Voltage input used

Rth rise(OFF): >10 kΩ
Rth fall(ON): < 45 Ω

Digital Output - 3 pcs. NPN transistor output

External supply: 7 – 24 V DC (same supply as for ICAD can be used, but please note that the galvanically isolated system will then be spoiled).
On resistance: 55 Ω + diode voltage 0.7 V DC
Max 70 Ω at 50 mA
Max Output current: 50 mA
Reverse polarity protection: Yes
Overcurrent protection: No

Temperature range (ambient)

-30 °C/+50 °C (-22 °F/122 °F)

Enclosure

IP67 (~NEMA 6)

Electrical connection

Connection to ICAD is done via M12 connectors. ICAD has two M12 male and one M12 female connectors build-in:

Power supply: 4 poled M12 male connector
Control signals: 8 poled M12 male connector
Data communication: 4 poled M12 female connector

Power Supply cable with 4 poled M12 female connector

4 x 0.34 mm² (4 x ~22 AWG) (fig. 6)
I: Black (+) 19 – 24 V DC fail safe supply (optional)
II: White (+) 24 V DC
III: Brown (-) 24 V DC
IIII: Blue (+) UPS signal of health

Control cable with 8 poled M12 female connector

7 x 0.25 mm² (7 x ~24 AWG) (fig. 7)
A: Black (-) Digital output Common Alarm
B: Brown (-) Digital output ICM fully open
C: Red (-) Digital output ICM fully closed
D: Orange (-) GND - Ground
E: Yellow (+) Analog input 0/4 – 20 mA)
F: Green (+) Analog input 0/2 – 10 V / DI1 - Digital ON/OFF input.
G: Blue (+) Analog output 0/4 – 20 mA)

Data communication cable with 4 poled M12 male connector:

	RS 485 / Ethernet	RS 485 / Ethernet
1:	White/Blue (-) / TX+	Data – (B) / Transmit Pair(+)
2:	White/Orange GND / RX+	Ground / Receiving Pair(+)
3:	Blue (+) / TX-	Data + (A) / Transmit Pair(-)
4:	Orange GND / RX-	Ground / Receiving Pair(-)

Electrical installation

General procedure for ICAD 600B/ICAD 600B-TS/1200B installed on all ICM, ICMTS & CVE valves.

All necessary electrical connections to be made.

Fig. 6

- **Analog operation - 7 wired cable (A-G)**
Modulation control. Valve to be controlled from Danfoss electronics, type EKC/EKE (fig. 7), or third party electronics (like e.g. PLC).
– Connect analog input signals. Current (mA) or Voltage (V). See **Parameter list** for configuration of analog input signals
– Yellow (+) and Orange (GND) are used for current (mA) input
or
– Green (+) and Orange (GND) are used for Voltage (V) input
– Blue (+) and Orange (GND) are used for current (mA) output (optional, not mandatory)

Fig. 6

- **Digital operation - 7 wired cable (A-G)**
ON/OFF ICM solenoid valve operation. ICM valve to be controlled by means of a digital voltfree contact.
– Connect digital input signals (fig. 8). See **Parameter list** for configuration of digital input signals
– Green (+) and Orange (GND) are connected to a voltfree contact

Digital output signals are optional, not mandatory.

- Black (-) and Orange (GND) are connected to auxiliary relay for Common Alarm
- Brown (-) and Orange (GND) are connected to an auxiliary relay indicating ICM fully open
- Red (-) and Orange (GND) are connected to an auxiliary relay indicating ICM fully closed

- **Supply voltage - 4 wired cable (I, II, III, IIII)**
ICAD must be connected to a normal 24 V DC supply. As an option, a fail safe supply is possible by means of a battery or UPS (Uninterruptible Power Supply). When voltage is applied as described below, ICAD is ready to be configured. See **Parameter list**.
ICAD configuration can be done independently whether the ICAD is installed on the valve or not. See **Mechanical installation**.
– Connect the White (+) and Brown (-) to 24 V DC supply voltage (fig. 6)
Fail safe supply as an option (not mandatory).
– Connect the Black (+) and Brown (-) to a fail safe supply.

Mechanical installation

General procedure for ICAD 600B/ICAD 600B-TS/1200B installed on all valves (fig. 3).

- Check that the two socket screws are fully unscrewed counter clockwise with a 3 mm Hexagon key
- If valve is fitted with PTFE ring and O-ring, remove both and replace it with O-ring included in ICAD (as instructed in fig. 3)
- Mount ICAD by slowly lowering it on top of the valve.
- The magnet coupling will drag the valve and ICAD together and in position
- Push ICAD in place
- Fasten valve and ICAD with the two socket set screws using a 3 mm Hexagon key



Special moisture seal is damaged if screws are removed (fig. 3).

Power on & start operation

ICAD has a light guide viewable from three sides, which indicates the status. Immediately after power on the light guide and display lights up.

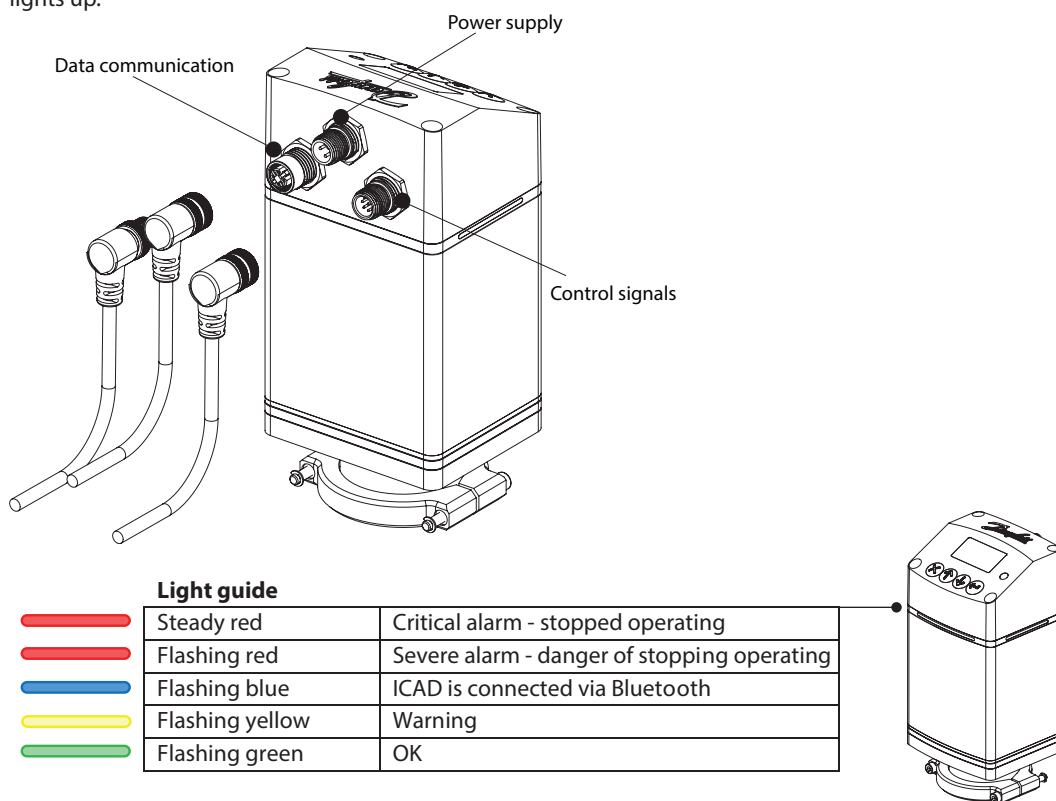

The main screen layout and navigation is as described below. ICAD will start up in alarm mode as the ICM configuration needs to be defined to start operation. Follow the steps on next page to set this up correctly.

STATUS BAR

Alarm | Warning | Service overdue | Modbus address | Bluetooth ON | UPS enabled

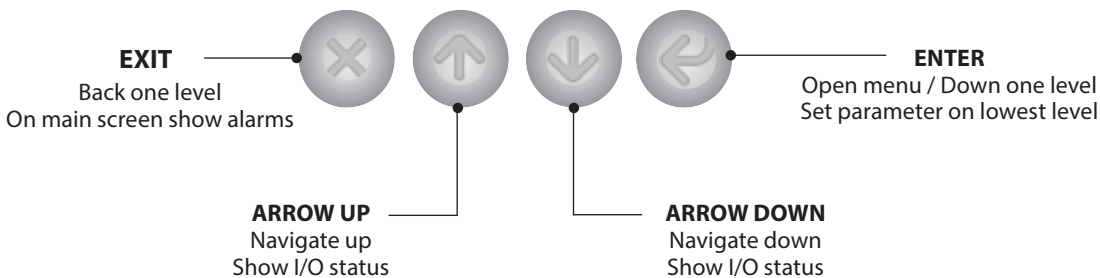
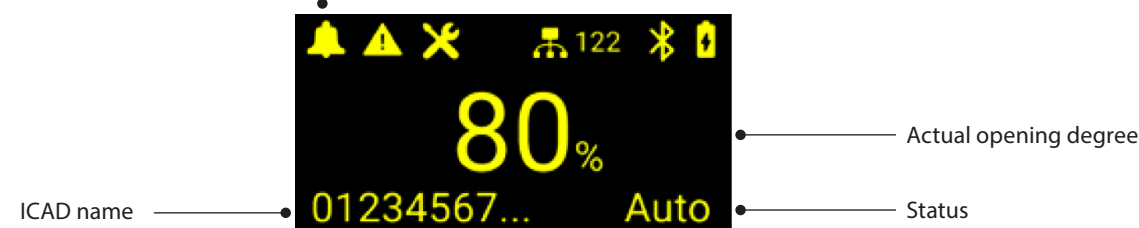

Set valve (A1 alarm)

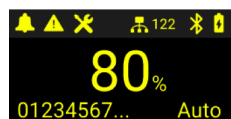

Press enter ↵

*Pressing and holding ↵ will go directly to the passcode screen

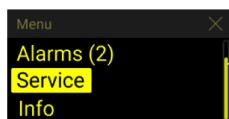

Press down ↓ until Service is selected, then press enter ↵

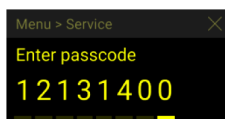

Enter the 8 digit service passcode* using ↑ ↓ press enter ↵ to enter next number
*factory is 12131400

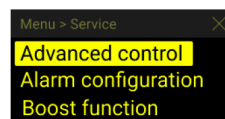

Navigate to **Advanced control** in the service menu using ↓, then press enter ↵

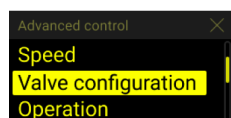

Navigate to **Valve configuration** using ↓, then press enter ↵

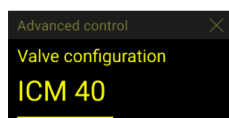

Select the ICM size or CVE. Press enter ↵ to set, and you will be navigated back to the previous screen. Continue to next step or press X to get back to main screen

VALVE CONFIGURATION HELP

ICAD 600B		
- ICM 20	—	
- ICM 25	—	
- ICM 32	—	
ICAD 1200B		
- ICM 40	—	
- ICM 50	—	
- ICM 65	—	
- ICM 100	—	
- ICM 125	—	
- ICM 150	—	
- CVE	—	
ICAD 600B TS		
-ICM 20	—	
-ICM 50	—	
-ICM 80	—	

Change analog input signal (optional)

ICAD will function based on factory settings as soon as the valve configuration has been set. The default settings are Modulation using an analog input of 4–20 mA.

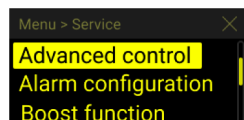

Navigate back from the advanced control menu using X

If starting from main screen press enter ↵ and navigate to the service menu like in previous step.

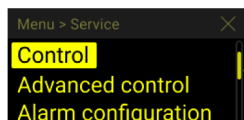

Now navigate to **Control** in the service menu using ↑, then press enter ↵

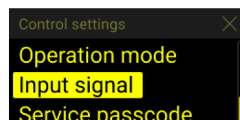

Next navigate to **Input signal** in the service menu using ↓, then press enter ↵

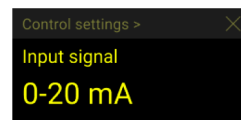

Select the desired input signal. Press enter ↵ to set, and you will be navigated back to the previous screen.

Press X to get back to main screen

Bluetooth connection

In addition to the onboard display, all configuration and readings from ICAD B actuator can be performed via Bluetooth (using Coolcong mobile app) or via data communication.

CoolConfig can be downloaded and installed from iTunes Store or Google Play Store.

To connect with ICAD actuator, click Start scanning in CoolConfig and the list of available devices will be provided. To connect with a device, a password will be required.

The connection PIN is 0000 and serves to ensure that the connection is intentionally. Access is then read-only.

Further languages and documentation



www.icadb.danfoss.com

Danfoss A/S

Climate Solutions • danfoss.com • +45 7488 2222

Any information, including, but not limited to information on selection of product, its application or use, product design, weight, dimensions, capacity or any other technical data in product manuals, catalogues descriptions, advertisements, etc. and whether made available in writing, orally, electronically, online or via download, shall be considered informative, and is only binding if and to the extent, explicit reference is made in a quotation or order confirmation. Danfoss cannot accept any responsibility for possible errors in catalogues, brochures, videos and other material. Danfoss reserves the right to alter its products without notice. This also applies to products ordered but not delivered provided that such alterations can be made without changes to form, fit or function of the product.

All trademarks in this material are property of Danfoss A/S or Danfoss group companies. Danfoss and the Danfoss logo are trademarks of Danfoss A/S. All rights reserved.