

ENGINEERING
TOMORROW

Danfoss

Brochure | iC2-Micro & VLT® Micro Drive FC 51

Comparison of features and specifications for iC2-Micro and VLT® Micro Drive FC 51



Run reliably at full
load for ambient
temperatures up to

50 °C

 drives.danfoss.com



Contents

General comparison of iC2-Micro and VLT® Micro Drive FC 51	3
Model code and type code comparison	4
Product models comparison	5
Comparison of dimensions and mounting clearance	6
Comparison of terminals	8

For your convenience in selecting and retrofitting drives, we provide some key comparative features and specifications of the iC2-Micro and VLT® Micro Drive FC 51.



iC2-Micro



VLT® Micro Drive FC 51

General **comparison** of iC2-Micro and VLT® Micro Drive FC 51

Key specifications

Attribute	iC2-Micro	VLT® Micro Drive FC 51
3-phase 380-480 V	0.37 – 22 kW	0.37 – 22 kW
1-phase 200-240 V	0.37 – 2.2 kW	0.18 – 2.2 kW
3-phase 200-240 V	0.37 – 11 kW ¹⁾	0.25 – 3.7 kW
1-phase 100-120 V	0.37 – 1.1 kW	N.A.
Enclosure	IP20/Open type	IP20/Open type
Motor type	IM, PM (SPM & IPM)	Only IM
Motor identification	Automatic Motor Adaptation (AMA)	Automatic Motor Tuning (AMT)
Output frequency	Induction motor <ul style="list-style-type: none"> • 0-200 Hz (VVC+ mode) • 0-500 Hz (U/f mode) PM motor <ul style="list-style-type: none"> • 0-400 Hz (VVC+ mode) 	Induction motor <ul style="list-style-type: none"> • 0-200 Hz (VVC+ mode) • 0-400 Hz (U/f mode)
Ramp time	0.01-3600 sec	0.05-3600 sec
Overload capacity	150% for 1 minute	150% for 1 minute
Overload torque at start	200%/1s	N.A.
Maximum motor cable length (unshielded)	75 m (246 ft)	50 m (164 ft)
EMC filter	Two versions: <ul style="list-style-type: none"> • Built-in EMC filter • Without built-in EMC filter 	Built-in EMC filter
Cooling fan	Replaceable fan with fan on/off control	Fixed fan without fan control
Ambient temperature	50°C (122°F) at full load Max. 55°C (131°F) with derating	40°C (104°F) at full load Max. 50°C (122°F) with derating
Natural cooling	Frame size MA01c	N.A.
HMI	Built-in control panel with potentiometer as default. Control Panel 2.0 OP2 as external control panel option: <ul style="list-style-type: none"> • Multi-language texts display • Easy for commissioning • Parameters setting and copy • Support two kinds of cabinet mounting kit <input checked="" type="checkbox"/> For control panel details, refer to the Application Guide	Detachable numerical control panel as option: <ul style="list-style-type: none"> • VLT® Control Panel LCP 11 without potentiometer • VLT® Control Panel LCP12 with potentiometer <input checked="" type="checkbox"/> For control panel details, refer to the Programming Guide
PC tool	MyDrive® Insight	VLT® Motion Control Tool MCT 10
Off-line configuration	With adapter option, support off-line configuration	N.A.
Torque control	Torque open loop control	N.A.
Process controller	PID controller	PI controller
Logical control	Smart Logic Controller (SLC)	Smart Logic Controller (SLC)
RS485 port baud rate	Max. 115,000 baud communication speed	Max. 38,400 baud communication speed
Extra RJ45 port	RS485 based, and used for connecting external control panel and PC tool.	N.A.
Safety standards	EN/IEC 61800-5-1, UL 61800-5-1	EN/IEC 61800-5-1, UL 508C
UL LZGH2/8 certification	Certified in accordance with UL/IEC 60335-2-40 and CSA C22.2 No.0335-2-40	N.A.
New features	<ul style="list-style-type: none"> • Kinetic backup • Clockwise direction • Latch start reverse • Input phase loss trip • Setting wizard with application selections • Dead zone control • Sleep mode function 	N.A.

¹⁾ 5.5-11 kW will be available soon



Model code and type code comparison

iC2-Micro model code definition

1	2	3	4	5	6	7	8	9	10	11	12	13	14	15	16	17	18	19	20	21	22	23	24	25	26	27
i	C	2	-	3	0	F	A	3	N	0	4	-	0	1	A	2	E	2	0	F	4	+	A	C	X	X
								1	N	0	2									F	2		A	C	B	C
										0	1									F	0					

Product group
iC2-30

Product category
FA Frequency converter air cooled

Product type
3N Three phases
1N Single phase

Mains voltage
04 380-480 V AC
02 200-240 V AC
01 100-120 V AC

***Current rating**
*See current rating on page 5

Protection rating
E20 IP20/Open Type

EMC category
F4 C4 category
F2 C2 category
F0 C1 category

Brake chopper
+ACXX None
+ACBC Integrated

VLT® Micro Drive FC 51 type code definition

1	2	3	4	5	6	7	8	9	10	11	12	13	14	15	16	17	18	19	20	21	22	23	24	25	26	27
F	C	-	0	5	1	P	K	3	7	T	4	E	2	0	H	3	X	X	C	X	X	X	S	X	X	X
										T	2				H	X	B									
										S	2															

Product series
VLT® Micro Drive FC51

***Power size**
*See power rating on page 5

Mains voltage
S2 Single phase 200-240 V AC
T2 Three phases 200-240 V AC
T4 Three phases 380-480 V AC

Protection rating
E20 IP20/Chassis

RFI filter
H3 RFI Class A1/B
HX No RFI filter

Hardware, coating
C Coated PCB

Hardware display
X No display
B Brake chopper

Hardware, mains option
X No mains option

Hardware, adaption A
X No adaption

Hardware, adaption B
X No adaption

SXXX Standard SW

Brake chopper
X No brake chopper
B Brake chopper

Product models comparison

Voltage 1 x 100-120 V AC

Power rating [kW/ hp]	Current rating [A]	iC2-Micro				VLT® Micro Drive FC 51			
		Model code	Enclosure	EMC level	Brake chopper	Type code	Enclosure	EMC level	Brake chopper
0.37/ 0.5	2.4	iC2-30FA1N01-02A4E20F4+ACXX	MA01c	C4	No	N.A.			
1.1/ 1.5	4.8	iC2-30FA1N01-04A8E20F4+ACXX	MA02c	C4	No	N.A.			

Voltage 1 x 200-240 V AC

Power rating [kW/ hp]	Current rating [A]	iC2-Micro				VLT® Micro Drive FC 51			
		Model code	Enclosure	EMC level	Brake chopper	Type code	Enclosure	EMC level	Brake chopper
0.18/ 0.24	1.2	N.A.				FC-51PK18S2E20H3XXCXXXSXXX	M1	C1	No
0.37/ 0.5	2.2	iC2-30FA1N02-02A2E20F0+ACXX iC2-30FA1N02-02A2E20F4+ACXX	MA01c	C1 & C4	No	FC-51PK37S2E20H3XXCXXXSXXX	M1	C1	No
0.75/ 1.0	4.2	iC2-30FA1N02-04A2E20F0+ACXX iC2-30FA1N02-04A2E20F4+ACXX	MA01c	C1 & C4	No	FC-51PK75S2E20H3XXCXXXSXXX	M1	C1	No
1.5/ 2.0	6.8	iC2-30FA1N02-06A8E20F0+ACXX iC2-30FA1N02-06A8E20F4+ACXX	MA02c	C1 & C4	No	FC-51P1K5S2E20H3BXCXXXSXXX	M2	C1	No
2.2/ 3.0	9.6	iC2-30FA1N02-09A6E20F0+ACXX iC2-30FA1N02-09A6E20F4+ACXX	MA02a	C1 & C4	No	FC-51P2K2S2E20H3BXCXXXSXXX	M3	C1	No

Voltage 3 x 200-240 V AC ¹⁾

Power rating [kW/hp]	Current rating [A]	iC2-Micro				VLT® Micro Drive FC 51			
		Model code	Enclosure	EMC level	Brake chopper	Type code	Enclosure	EMC level	Brake chopper
0.18/0.24	1.2	N.A.				FC-51PK25T2E20H3XXCXXXSXXX	M1	C2	No
0.37/0.5	2.4	iC2-30FA3N02-02A4E20F4+ACXX	MA01a	C4	No	FC-51PK37T2E20H3XXCXXXSXXX	M1	C2	No
0.75/1.0	4.2	iC2-30FA3N02-04A4E20F4+ACXX	MA01a	C4	No	FC-51PK75T2E20H3XXCXXXSXXX	M1	C2	No
1.5/2.0	7.8	iC2-30FA3N02-07A8E20F4+ACBC	MA02a	C4	Yes	FC-51P1K5T2E20H3BXCXXXSXXX	M2	C2	No
2.2/3.0	11	iC2-30FA3N02-11A8E20F4+ACBC	MA03a	C4	Yes	FC-51P2K2T2E20H3BXCXXXSXXX	M3	C2	No
3.7/5.0	15.2	iC2-30FA3N02-15A8E20F4+ACBC	MA03a	C4	Yes	FC-51P3K7T2E20H3BXCXXXSXXX	M3	C2	No
5.5/7.5	24.2	iC2-30FA3N02-24A2E20F4+ACBC	MA04a	C4	Yes	N.A.			
7.5/10	31.0	iC2-30FA3N02-31A0E20F4+ACBC	MA04a	C4	Yes				
11/15	46.2	iC2-30FA3N02-46A2E20F4+ACBC	MA05a	C4	Yes				

¹⁾ 5.5-11 kW will be available soon

Voltage 3 x 380-480 V AC

Power rating [kW/hp]	Current rating [A]	iC2-Micro				VLT® Micro Drive FC 51			
		Model code	Enclosure	EMC level	Brake chopper	Type code	Enclosure	EMC level	Brake chopper
0.37/0.5	1.2	iC2-30FA3N04-01A2E20F2+ACXX iC2-30FA3N04-01A2E20F4+ACXX	MA01a	C2 & C4	No	FC-51PK37T4E20H3XXCXXXSXXX	M1	C2	No
0.75/1.0	2.2	iC2-30FA3N04-02A2E20F2+ACXX iC2-30FA3N04-02A2E20F4+ACXX	MA01a	C2 & C4	No	FC-51PK75T4E20H3XXCXXXSXXX	M1	C2	No
1.5/2.0	3.7	iC2-30FA3N04-03A7E20F2+ACXX iC2-30FA3N04-03A7E20F4+ACXX	MA01a	C2 & C4	No	FC-51P1K5T4E20H3BXCXXXSXXX	M2	C2	Yes
2.2/3.0	5.3	iC2-30FA3N04-05A3E20F2+ACBC iC2-30FA3N04-05A3E20F4+ACBC	MA02a	C2 & C4	Yes	FC-51P2K2T4E20H3BXCXXXSXXX	M2	C2	Yes
3.0/4.0	7.2	iC2-30FA3N04-07A2E20F2+ACBC iC2-30FA3N04-07A2E20F4+ACBC	MA02a	C2 & C4	Yes	FC-51P3K0T4E20H3BXCXXXSXXX	M3	C2	Yes
4.0/5.5	9.0	iC2-30FA3N04-09A0E20F2+ACBC iC2-30FA3N04-09A0E20F4+ACBC	MA02a	C2 & C4	Yes	FC-51P4K0T4E20H3BXCXXXSXXX	M3	C2	Yes
5.5/7.5	12.0	iC2-30FA3N04-12A0E20F2+ACBC iC2-30FA3N04-12A0E20F4+ACBC	MA03a	C2 & C4	Yes	FC-51P5K5T4E20H3BXCXXXSXXX	M3	C2	Yes
7.5/10	15.5	iC2-30FA3N04-15A5E20F2+ACBC iC2-30FA3N04-15A5E20F4+ACBC	MA03a	C2 & C4	Yes	FC-51P7K5T4E20H3BXCXXXSXXX	M3	C2	Yes
11/15	23.0	iC2-30FA3N04-23A0E20F2+ACBC iC2-30FA3N04-23A0E20F4+ACBC	MA04a	C2 & C4	Yes	FC-51P11KT4E20H3BXCXXXSXXX	M4	C2	Yes
15/20	31.0	iC2-30FA3N04-31A0E20F2+ACBC iC2-30FA3N04-31A0E20F4+ACBC	MA04a	C2 & C4	Yes	FC-51P15KT4E20H3BXCXXXSXXX	M4	C2	Yes
18.5/25	37.0	iC2-30FA3N04-37A0E20F2+ACBC iC2-30FA3N04-37A0E20F4+ACBC	MA05a	C2 & C4	Yes	FC-51P18KT4E20H3BXCXXXSXXX	M5	C2	Yes
22/30	43.0	iC2-30FA3N04-43A0E20F2+ACBC iC2-30FA3N04-43A0E20F4+ACBC		C2 & C4	Yes	FC-51P22KT4E20H3BXCXXXSXXX	M5	C2	Yes

Comparison of **dimensions** and **mounting clearance**

Voltage type	Power rating [kW/hp]	iC2-Micro						VLT® Micro Drive FC 51					
		Height [H]	Width [W]	Depth [D]	Height [H1]	Width [W1]	Weight [kg]	Height [H]	Width [W]	Depth [D]	Height [H1]	Width [W1]	Weight [kg]
1 x 100 V		MA01c						N.A.					
	0.37/0.5	150 (5.9)	70 (2.8)	143 (5.6)	140.4 (5.5)	55 (2.2)	1.0						
1 x 100 V		MA02c						N.A.					
	1.1/1.5	176 (6.9)	75 (3.0)	157 (6.2)	150.5 (5.9)	59 (2.3)	1.3						
1 x 220 V	0.18/0.24	N.A.						M1					
								150 (5.9)	70 (2.8)	148 (5.8)	140.4 (5.5)	55 (2.2)	1.1
		MA01c						M1					
	0.37/0.5	150 (5.9)	70 (2.8)	143 (5.6)	140.4 (5.5)	55 (2.2)	1.0	150 (5.9)	70 (2.8)	148 (5.8)	140.4 (5.5)	55 (2.2)	1.1
	0.75/1.0												
	1.5/2.0	176 (6.9)	75 (3.0)	157 (6.2)	150.5 (5.9)	59 (2.3)	1.3	176 (6.9)	75 (3.0)	168 (6.6)	166.4 (6.6)	59 (2.3)	1.6
3 x 220 V	2.2/3.0	186 (7.3)	75 (3.0)	175 (6.9)	176.4 (6.9)	59 (2.3)	1.6	238.5 (9.4)	90 (3.5)	194 (7.6)	226 (8.9)	69 (2.7)	3
		MA02a						M3					
		MA01a						M1					
	0.18/0.24	N.A.											
	0.37/0.5	150 (5.9)	70 (2.8)	158 (6.2)	140.4 (5.5)	55 (2.2)	1.1	150 (5.9)	70 (2.8)	148 (5.8)	140.4 (5.5)	55 (2.2)	1.1
	0.75/1.0												
3 x 220 V	1.5/2.0	186 (7.3)	75 (3.0)	175 (6.9)	176.4 (6.9)	59 (2.3)	1.6	176 (6.9)	75 (3.0)	168 (6.6)	166.4 (6.6)	59 (2.3)	1.6
		MA02a						M2					
		MA03a						M3					
	2.2/3.0	238.5 (9.4)	90 (3.5)	200 (7.9)	226 (8.9)	69 (2.7)	3.0	238.5 (9.4)	90 (3.5)	194 (7.6)	226 (8.9)	69 (2.7)	3.0
	3.7/5.0												
		MA04a						N.A.					
	5.5/7.5	292 (11.5)	125 (4.9)	244.5 (9.6)	272.4 (10.7)	97 (3.8)	6.0						
		MA05a											
11/15	335 (13.2)	165 (6.5)	248 (9.8)	315 (12.4)	140 (5.5)	9.4 (20.7)							
3 x 400 V		MA01a						M1					
	0.37/0.5	150 (5.9)	70 (2.8)	158 (6.2)	140.4 (5.5)	55 (2.2)	1.1	150 (5.9)	70 (2.8)	148 (5.8)	140.4 (5.5)	55 (2.2)	1.1
	0.75/1.0												
		MA01a						M2					
	1.5/2.0	150 (5.9)	70 (2.8)	158 (6.2)	140.4 (5.5)	55 (2.2)	1.1	176 (6.9)	75 (3.0)	168 (6.6)	166.4 (6.6)	59 (2.3)	1.6
		MA02a						M2					
	2.2/3.0	186 (7.3)	75 (3.0)	175 (6.9)	176.4 (6.9)	59 (2.3)	1.6	176 (6.9)	75 (3.0)	168 (6.6)	166.4 (6.6)	59 (2.3)	1.6
		MA02a						M3					
	3.0/4.0	186 (7.3)	75 (3.0)	175 (6.9)	176.4 (6.9)	59 (2.3)	1.6	238.5 (9.4)	90 (3.5)	194 (7.6)	226 (8.9)	69 (2.7)	3.0
	4.0/5.5												
		MA03a						M3					
	5.5/7.5	238.5 (9.4)	90 (3.5)	200 (7.9)	226 (8.9)	69 (2.7)	3.0	238.5 (9.4)	90 (3.5)	194 (7.6)	226 (8.9)	69 (2.7)	3.0
	7.5/10												
		MA04a						M4					
11/15	292 (11.5)	125 (4.9)	244.5 (9.6)	272.4 (10.7)	97 (3.8)	6.0	292 (11.5)	125 (5.0)	241 (9.5)	272.4 (10.7)	97 (3.8)	6.0	
15/20													
	MA05a						M5						
18.5/25	335 (13.2)	165 (6.5)	248 (9.8)	315 (12.4)	140 (5.5)	9.4 (20.7)	335 (13.2)	165 (6.5)	248 (9.8)	315 (12.4)	140 (5.5)	9.5	
22/30													

H = Height [mm (in)], W = Width [mm (in)], D = Depth [mm (in)], H1 = Height [mm (in)], W1 = Width [mm (in)]

Note

- H, W and D are for overall dimensions
- H1 and W1 are for mounting hole dimensions
- The potentiometer on the local control panel extends 6.5 mm (0.26 in) from the drive.

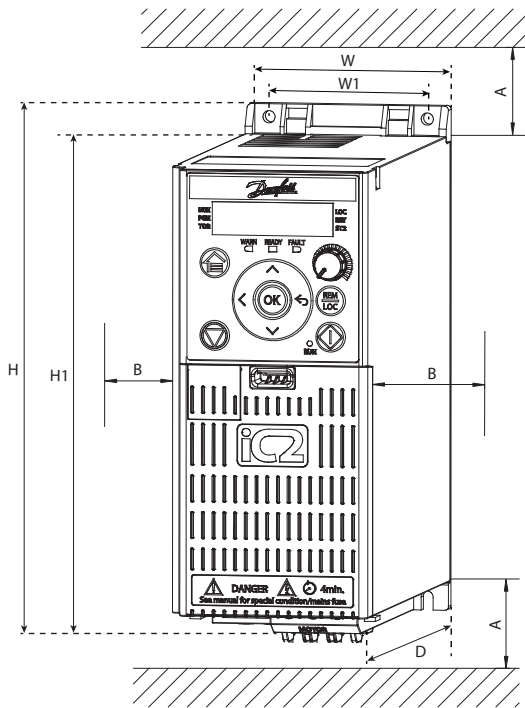

iC2-Micro

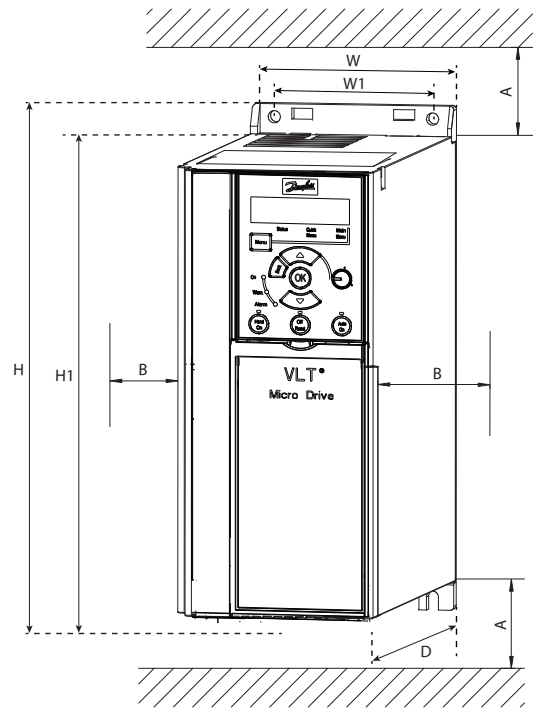

VLT® Micro Drive FC 51



Easy retrofit
 iC2-Micro is designed to be compatible with the VLT® Micro Drive FC 51, for a fast, streamlined retrofit

Mounting clearance

	iC2-Micro		VLT® Micro Drive FC 51	
Direction	Frame designation	Minimum cooling clearances	Enclosure size	Minimum cooling clearances
Above and below (A)	All frame designations	100 mm (3.9 in) for 50 °C (122 °F)	All enclosure sizes	100 mm (3.9 in) for 40 °C (104 °F)
	MA01a to MA05a, MA02c	0 mm (0 in) for 50 °C (122 °F)		
Sides (B)	MA01c (natural cooling)	0 mm (0 in) for 40 °C (104 °F)	All enclosure sizes	0 mm (0 in) for 40 °C (104 °F)
		10 mm (0.39 in) and above for 50 °C (122 °F)		



Comparison of terminals

Terminals

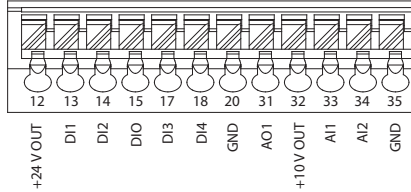
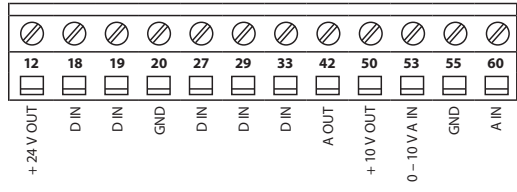
Attribute	iC2-Micro	VLT® Micro Drive FC 51
Terminal type	Spring type	Screw type
I/O terminals	Terminal number	Terminal number
	Type	Type
	T12	24V
	T13	DI1
	T14	DI2
	T15	DIO
	T17	DI3
	T18	DI4
	T20	GND
	T31	AO1
	T32	10V
	T33	AI1
	T34	AI2
T35	GND	
	01, 02, 03	Relay
Digital output	Programmable T15 could be set as digital output. Max. output current is 40 mA	Programmable T42 could be set as digital output. Max. output current is 20 mA
Pulse input	Programmable T18 can be set as pulse input (4-32 kHz)	Programmable T33 can be set as pulse input (20-5000 Hz)
Pulse output	Programmable T15 can be set as pulse output (4-32 kHz)	N.A.
Analog inputs mode switch	By software paramter	By hardware switch
PNP & NPN switch	By software paramter	By hardware switch
Illustration		

How to order

To order, go to store.danfoss.com and choose country/region.



iC2-Micro is the convenient drive that gives you a new way to optimize efficiency and cost. With its compact design, it saves panel space to reduce system cost. Since it is compatible with diverse motor technologies such as induction, IPM and SPM, you can freely select the best-fit motor for your application. It's easy to commission, since it's equipped with startup wizards and application-oriented parameter groups. What are you waiting for? Here is the compact drive that's reliable and flexible, ready to power your pumps, fans, conveyors and mixers, textile machinery, palletizers, and packaging machines.

iC2

Follow us and learn more about AC drives

