

Datasheets

# BD250GH.2 Direct Current Compressor R134a, 12/24V DC

**General**

Code number (without electronic units)	101Z0406
Electronic unit - High Speed	101N0390, 28 pcs: 101N0391
Compressors on pallet	150



**Application**

Application	LBP/MBP/HBP
Evaporating temperature °C	-25 to 15
Voltage range VDC	9.6 - 17 / 21.3 - 31.5
Max. condensing temperature continuous (short) °C	60 (70)
Max. winding temperature continuous (short) °C	125 (135)

**Cooling requirements**

Application	LBP	MBP	HBP
32°C	S	S	S
38°C	S	S	S
43°C	S	S	S
Remarks on application:			

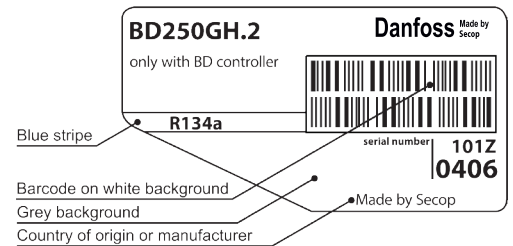

**Motor**

Motor type	variable speed
Resistance, all 3 windings (25°C) Ω	1.8

- S = Static cooling normally sufficient
- O = Oil cooling
- F<sub>1</sub> = Fan cooling 1.5 m/s  
(compressor compartment temperature equal to ambient temperature)
- F<sub>2</sub> = Fan cooling 3.0 m/s necessary
- SG = Suction gas cooling normally sufficient
- = not applicable in this area

**Design**

Displacement cm <sup>3</sup>	2.50
Oil quantity (type) cm <sup>3</sup>	150 (polyolester)
Maximum refrigerant charge g	300
Free gas volume in compressor cm <sup>3</sup>	870
Weight - Compressor/Electronic unit kg	4.4/0.32

**Standard battery protection settings** (refer to electronic unit *Instructions* for optional settings)

Voltage	12V	24V
Cut out VDC	10.4	22.8
Cut in VDC	11.7	24.2

**Dimensions**

Height	mm	A	137
		B	135
		B1	128
		B2	73
Suction connector	location/I.D. mm   angle	C	6.2   40°
	material   comment	Cu-plated steel   Al cap	
Process connector	location/I.D. mm   angle	D	6.2   45°
	material   comment	Cu-plated steel   Al cap	
Discharge connector	location/I.D. mm   angle	E	5.0   21°
	material   comment	Cu-plated steel   Al cap	
Connector tolerance	I.D. mm	±0.09, on 5.0 +0.12/+0.20	
Remarks:			

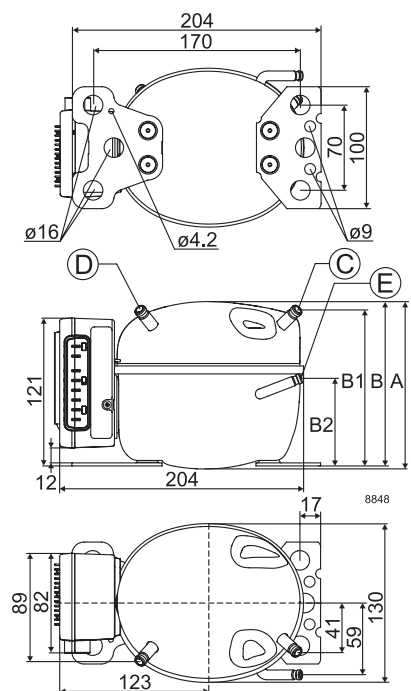



Capacity (EN 12900 Household/CECOMAF) 24V DC, static cooling watt												
rpm \ °C	-25	-23.3	-20	-15	-10	-6.7	-5	0	5	7.2	10	15
2,500	31.3	38.1	50.8	70.0	90.5	106	114	142	177	194	219	271
3,100	42.9	48.5	61.0	83.5	111	132	143	181	225	246	275	332
3,800	54.6	61.9	77.7	106	140	165	179	225	278	303	337	404
4,400	61.2	69.4	87.2	119	156	184	200	251	308	336	373	446

Capacity (ASHRAE LBP) 24V DC, static cooling watt												
rpm \ °C	-25	-23.3	-20	-15	-10	-6.7	-5	0	5	7.2	10	15
2,500	38.3	46.8	62.6	86.6	112	131	142	177	220	242	274	340
3,100	53.4	60.4	75.9	104	138	164	178	225	280	307	343	415
3,800	68.1	77.1	96.7	132	173	205	223	280	345	377	420	504
4,400	76.3	86.5	109	148	194	229	249	311	383	418	465	556

Power consumption 24V DC, static cooling watt												
rpm \ °C	-25	-23.3	-20	-15	-10	-6.7	-5	0	5	7.2	10	15
2,500	38.1	42.0	48.5	55.9	61.4	64.4	65.9	70.7	76.6	79.9	84.8	96.4
3,100	42.0	46.0	53.1	62.4	70.8	76.2	79.0	87.8	98	103	110	125
3,800	55.0	59.4	67.6	79.0	90.2	97.7	102	114	129	136	146	167
4,400	64.8	69.5	78.2	91	104	113	117	132	150	158	170	194

Current consumption (for 12V applications the following must be doubled) A												
rpm \ °C	-25	-23.3	-20	-15	-10	-6.7	-5	0	5	7.2	10	15
2,500	1.7	1.8	2.0	2.3	2.5	2.6	2.6	2.8	3.0	3.2	3.3	3.7
3,100	2.0	2.1	2.3	2.7	3.0	3.2	3.3	3.7	4.1	4.3	4.6	5.1
3,800	2.5	2.6	2.9	3.3	3.7	4.0	4.2	4.7	5.3	5.6	6.0	6.8
4,400	2.7	2.9	3.2	3.6	4.1	4.5	4.7	5.3	6.0	6.4	6.8	7.8

COP (EN 12900 Household/CECOMAF) 24V DC, static cooling W/W												
rpm \ °C	-25	-23.3	-20	-15	-10	-6.7	-5	0	5	7.2	10	15
2,500	0.82	0.91	1.05	1.25	1.47	1.64	1.73	2.01	2.31	2.43	2.58	2.82
3,100	1.02	1.05	1.15	1.34	1.56	1.73	1.81	2.06	2.30	2.40	2.51	2.66
3,800	0.99	1.04	1.15	1.34	1.55	1.69	1.76	1.97	2.15	2.22	2.30	2.42
4,400	0.94	1.00	1.11	1.31	1.51	1.64	1.71	1.89	2.06	2.12	2.20	2.30

COP (ASHRAE LBP) 24V DC, static cooling W/W												
rpm \ °C	-25	-23.3	-20	-15	-10	-6.7	-5	0	5	7.2	10	15
2,500	1.01	1.11	1.30	1.56	1.84	2.05	2.17	2.53	2.91	3.07	3.26	3.55
3,100	1.27	1.31	1.43	1.67	1.95	2.15	2.26	2.58	2.88	3.00	3.14	3.35
3,800	1.24	1.30	1.43	1.67	1.93	2.11	2.20	2.46	2.69	2.78	2.88	3.04
4,400	1.18	1.24	1.39	1.63	1.88	2.04	2.13	2.36	2.57	2.65	2.75	2.88

Test conditions	EN 12900/CECOMAF	ASHRAE LBP
Condensing temperature	55°C	54.4°C
Ambient temperature	32°C	32°C
Suction gas temperature	32°C	32°C
Liquid temperature	no subcooling	32°C

Accessories for BD250GH.2	Code number
Bolt joint for one comp.	Ø:16 mm 118-1917
Bolt joint in quantities	Ø:16 mm 118-1918
Snap-on in quantities	Ø:16 mm 118-1919
Remote kit (without cable)	105N9210
One Wire/LIN gateway	105N9501
Automobile fuse, DIN 7258	12V: 30A   24V: 15 A Not deliverable from Secop
Main switch	min. 30A

**Compressor speed**

Electronit unit	Resistor (R1) [Ω]	Motor speed
Code number	calculated values	[rpm]
	0	AEO
	203	2,500
	451	3,100
	867	3,800
101N0390 with AEO	1700	4,400

In AEO (Adaptive Energy Optimizing) speed mode the BD compressor will always adapt its speed to the actual cooling demand.

**Wire dimensions**

Cross section	Size AWG	Max. length* 12V operation		Max. length* 24V operation			
		[mm²]	[Gauge]	[m]	[ft.]	[m]	[ft.]
6	10			2.5	8	5	16

\*Length between battery and electronic unit

**Operational errors**

Error code or LED flashes	Error type
	Can be read out in the software <b>TOOL4COOL®</b>
6	<b>Thermostat failure</b> (If the NTC thermistor is short-circuit or has no connection).
5	<b>Thermal cut-out of electronic unit</b> (If the refrigeration system has been too heavily loaded, or if the ambient temperature is high, the electronic unit will run too hot).
4	<b>Minimum motor speed error</b> (If the refrigeration system is too heavily loaded, the motor cannot maintain minimum speed at approximately 1,850 rpm).
3	<b>Motor start error</b> (The rotor is blocked or the differential pressure in the refrigeration system is too high (>5 bar)).
2	<b>Too many start attempts or fan over current</b> (Too many compressor or fan starts in short time or fan current higher than 0.5A <sub>avg</sub> ).
1	<b>Battery protection cut-out</b> (The voltage is outside the cut-out setting).

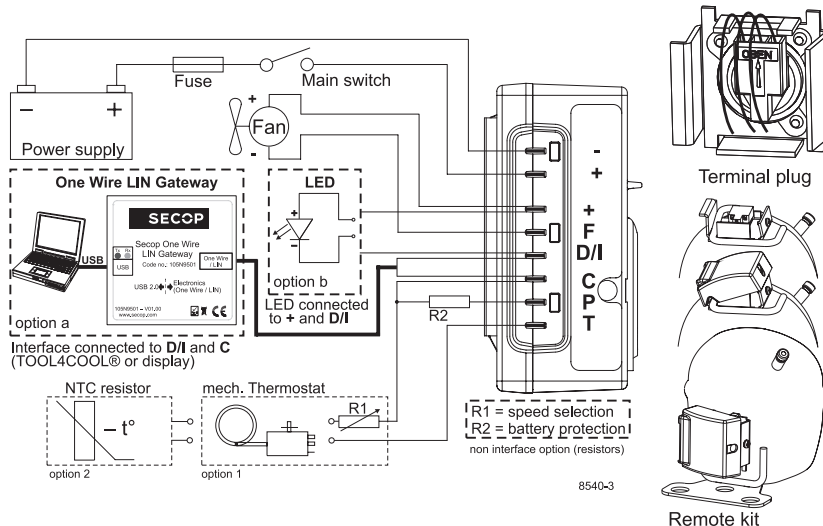

Danfoss can accept no responsibility for possible errors in catalogues, brochures and other printed material. Danfoss reserves the right to alter its products without notice. This also applies to products already on order provided that such alterations can be made without subsequent changes being necessary in specifications already agreed. All trademarks in this material are property of the respective companies. Danfoss and the Danfoss logotype are trademarks of Danfoss A/S. All rights reserved.