

BD250GH Direct Current Compressor R134a, 12-24V



General

Code number (without electronic units)	101Z0400
Electronic unit (with integrated fan cooling)	single: 101N0280, 28 pcs: 101N0281
Remote kit (optional)	w. cable: 105N9100, w/o. cable: 105N9210
Approvals (compressor)	UL984, CSA-C22.2
Approvals (electronic unit)	E4 72/245 95/54 0211 37
Compressors on pallet	150

Application

Application		LBP/MBP/HBP
Evaporating temperature	°C	-25 to 15
Voltage range/max. voltage	VDC	12-24/31.5
Max. condensing temperature continuous (short)	°C	60 (70)
Max. winding temperature continuous (short)	°C	125 (135)

Cooling requirements

Application	LBP	MBP	HBP
32°C	S	S	S
38°C	S	S	S
43°C	S	S	S
Remarks on application:			

Motor

Motor type		Variable speed
Resistance, all 3 windings (25°C)	Ω	1.8

Design

Displacement	cm ³	2.50
Oil quantity (type)	cm ³	150 (polyolester)
Maximum refrigerant charge	g	300
Free gas volume in compressor	cm ³	870
Weight - Compressor/Electronic unit	kg	4.4/0.3

Dimensions

Height	mm	A	137
		B	135
		B1	128
		B2	73
Suction connector	location/I.D. mm angle	C	6.2 41.5°
Process connector	location/I.D. mm angle	D	6.2 45°
Discharge connector	location/I.D. mm angle	E	5.0 21°
Connector tolerance	I.D. mm		±0.09, on 5.0 +0.12/+0.20

Standard battery protection settings (no connection C - P)

12V cut-out [V]	12V cut-in [V]	24V cut-out [V]	24V cut-in [V]
10.4	11.7	22.8	24.2

Optional battery protections settings

Resistor (R2)	12V cut-out	12V cut-in	12V max.	24V cut-out	24V cut-in	24V max.
[kΩ]	[V]	[V]	Voltage [V]	[V]	[V]	Voltage [V]
0	9.6	10.9	17.0	21.3	22.7	31.5
1.6	9.7	11.0	17.0	21.5	22.9	31.5
2.4	9.9	11.1	17.0	21.8	23.2	31.5
3.6	10.0	11.3	17.0	22.0	23.4	31.5
4.7	10.1	11.4	17.0	22.3	23.7	31.5
6.2	10.2	11.5	17.0	22.5	23.9	31.5
8.2	10.4	11.7	17.0	22.8	24.2	31.5
11	10.5	11.8	17.0	23.0	24.5	31.5
14	10.6	11.9	17.0	23.3	24.7	31.5
18	10.8	12.0	17.0	23.6	25.0	31.5
24	10.9	12.2	17.0	23.8	25.2	31.5
33	11.0	12.3	17.0	24.1	25.5	31.5
47	11.1	12.4	17.0	24.3	25.7	31.5
82	11.3	12.5	17.0	24.6	26.0	31.5
220	9.6	10.9				31.5

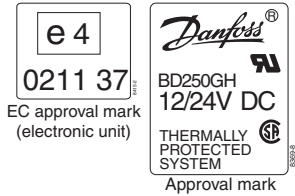
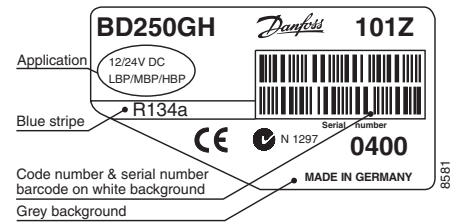

- S = Static cooling normally sufficient
- O = Oil cooling
- F₁ = Fan cooling 1.5 m/s
(compressor compartment temperature equal to ambient temperature)
- F₂ = Fan cooling 3.0 m/s necessary
- SG = Suction gas cooling normally sufficient
- = not applicable in this area

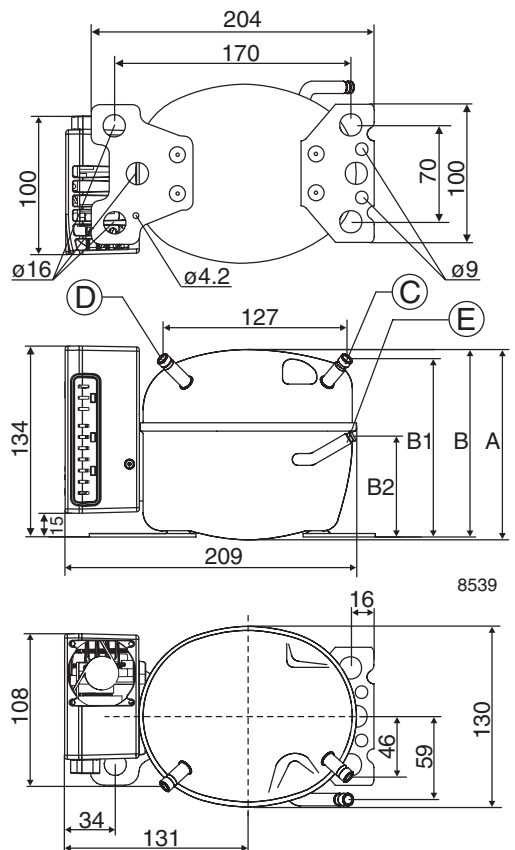

Capacity (EN 12900 Household/CECOMAF)

 12V DC static cooling **watt**

rpm \ °C	-25	-23.3	-20	-15	-10	-6.7	-5	0	5	7.2	10	15
2,500	38.0	42.6	52.3	69.7	90.6	107	115	145	179	196	219	264
3,100	46.2	51.6	63.2	83.8	109	128	138	173	214	234	262	316
3,800	56.0	62.5	76.5	101	131	154	167	208	257	281	314	379
4,400	62.9	70.7	87.0	116	149	175	189	236	290	316	353	425

Capacity (ASHRAE LBP)

 12V DC static cooling **watt**

rpm \ °C	-25	-23.3	-20	-15	-10	-6.7	-5	0	5	7.2	10	15
2,500	47.0	52.6	64.7	86.2	112	132	143	180	222	243	272	329
3,100	57.1	63.8	78.1	104	134	158	171	215	266	291	325	394
3,800	69.2	77.3	94.6	125	162	191	206	258	319	349	390	471
4,400	78.0	87.6	108	143	185	216	234	292	360	393	438	528

Power consumption

 12V DC static cooling **watt**

rpm \ °C	-25	-23.3	-20	-15	-10	-6.7	-5	0	5	7.2	10	15
2,500	40.7	43.4	48.9	57.6	66.7	72.9	76.1	85.5	94.7	98.7	104	112
3,100	50.7	54.0	60.4	70.7	81.7	89.3	93.3	105	118	124	132	145
3,800	63.0	67.1	75.1	87.9	102	111	116	132	150	158	169	190
4,400	72.7	77.7	87.6	103	120	131	138	157	179	189	203	230

Current consumption (for 24V applications the following must be halved)

 12V DC static cooling **A**

rpm \ °C	-25	-23.3	-20	-15	-10	-6.7	-5	0	5	7.2	10	15
2,500	3.40	3.62	4.08	4.80	5.56	6.07	6.34	7.12	7.89	8.22	8.64	9.35
3,100	4.23	4.50	5.03	5.89	6.81	7.44	7.77	8.79	9.85	10.34	10.97	12.12
3,800	5.25	5.59	6.26	7.33	8.47	9.27	9.70	11.04	12.49	13.18	14.09	15.83
4,400	6.05	6.47	7.30	8.59	9.97	10.94	11.46	13.10	14.91	15.77	16.92	19.18

COP (EN 12900 Household/CECOMAF)

 12V DC static cooling **W/W**

rpm \ °C	-25	-23.3	-20	-15	-10	-6.7	-5	0	5	7.2	10	15
2,500	0.93	0.98	1.07	1.21	1.36	1.46	1.52	1.69	1.89	1.98	2.11	2.36
3,100	0.91	0.96	1.05	1.18	1.33	1.43	1.48	1.64	1.81	1.89	1.99	2.17
3,800	0.89	0.93	1.02	1.15	1.29	1.38	1.43	1.57	1.72	1.78	1.86	1.99
4,400	0.87	0.91	0.99	1.12	1.25	1.33	1.37	1.50	1.62	1.67	1.74	1.85

COP (ASHRAE LBP)

 12V DC static cooling **W/W**

rpm \ °C	-25	-23.3	-20	-15	-10	-6.7	-5	0	5	7.2	10	15
2,500	1.16	1.21	1.33	1.50	1.68	1.82	1.89	2.11	2.36	2.48	2.64	2.96
3,100	1.13	1.18	1.30	1.47	1.65	1.78	1.85	2.05	2.26	2.36	2.49	2.73
3,800	1.10	1.15	1.26	1.43	1.60	1.72	1.78	1.96	2.14	2.22	2.32	2.50
4,400	1.07	1.13	1.23	1.39	1.55	1.65	1.71	1.87	2.02	2.09	2.17	2.31

Operational errors shown by LED (optional)

Number of flashes	Error type
5	Thermal cut-out of electronic unit (If the refrigeration system has been too heavily loaded, or if the ambient temperature is high, the electronic unit will run too hot).
4	Minimum motor speed error (If the refrigeration system is too heavily loaded, the motor cannot maintain minimum speed at approximately 2,450 rpm).
3	Motor start error (The rotor is blocked or the differential pressure in the refrigeration system is too high (>5 bar)).
2	Fan over-current cut-out (The fan loads the electronic unit with more than 1A _{peak}).
1	Battery protection cut-out (The voltage is outside the cut-out setting).

Wire Dimensions

Cross section	Size	Max. length* 12V operation		Max. length* 24V operation	
		[mm ²]	[Gauge]	[m]	[ft.]
8	8	2.5	8	5	16

*Length between battery and electronic unit

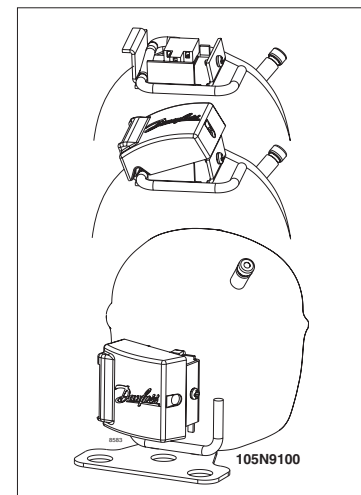
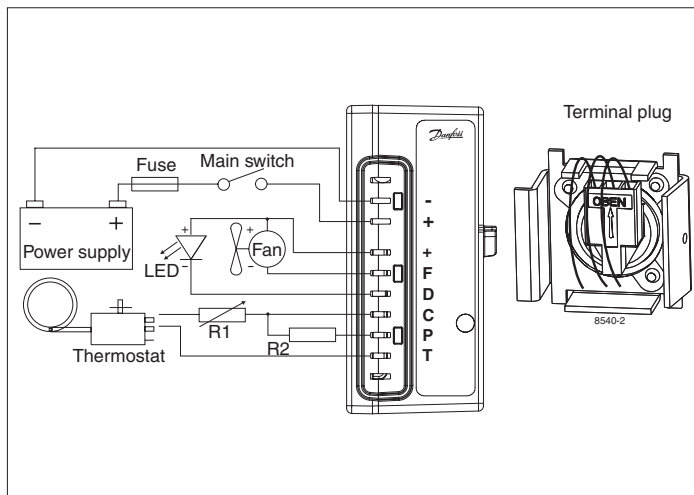
Compressor speed

Electronit unit Code number	Resistor (R1) [Ω]	Motor speed [rpm]	Control circuit current [mA]
101N0280 with AEO	0	AEO	6
	203	2,500	5
	451	3,100	4
	867	3,800	3
	1700	4,400	2

Test conditions	EN 12900/CECOMAF	ASHRAE
Condensing temperature	55°C	54.4°C
Ambient temperature	32°C	32°C
Suction gas temperature	32°C	32°C
Liquid temperature	no subcooling	32°C

Accessories for	BD250GH	Code number
Bolt joint for one compressor	Ø: 16 mm	118-1917
Bolt joint in quantities	Ø: 16 mm	118-1918
Snap-on in quantities	Ø: 16 mm	118-1919
Standard automobile fuse	12V: 30A 24V: 15A	Not deliverable from Danfoss
Main switch	rated to min. 30A	

In AEO (Adaptive Energy Optimizing) speed mode the BD compressor will always adapt its speed to the actual cooling demand.

Danfoss can accept no responsibility for possible errors in catalogues, brochures and other printed material. Danfoss reserves the right to alter its products without notice. This also applies to products already on order provided that such alterations can be made without subsequential changes being necessary in specifications already agreed. All trademarks in this material are property of the respective companies. Danfoss and the Danfoss logotype are trademarks of Danfoss A/S. All rights reserved.