

# BD250GH

## Direct Current Compressor

### R134a

### 48-56V DC



#### General

Code number (without electronic units)	101Z0402
Electronic unit - Telecom	101N0730, 36 pcs: 101N0731
Approvals	UL
Compressors on pallet	150

#### Application

Application		LBP/MBP/HBP
Evaporating temperature	°C	-25 to 15
Voltage range	VDC	32 - 60
Max. condensing temperature continuous (short)	°C	60 (70)
Max. winding temperature continuous (short)	°C	125 (135)

#### Cooling requirements

Application	LBP	MBP	HBP
32°C	S	S	S
38°C	S	S	S
43°C	S	S	S

Remarks on application:  
Even if the setting is 4,400 rpm the compressor will run with a fixed speed of 3,500 rpm at 48 V DC power supply when the thermostat is switched on. To obtain the max. speed of 4,400 rpm the supply voltage needs to be 56 V DC (each fan with max. 60W).

#### Motor

Motor type	variable speed
Resistance, all 3 windings (25°C)	Ω 1.8

#### Design

Displacement	cm <sup>3</sup>	2.50
Oil quantity (type)	cm <sup>3</sup>	150 (polyolester)
Maximum refrigerant charge	g	300
Free gas volume in compressor	cm <sup>3</sup>	870
Weight - Compressor/Electronic unit	kg	4.4/0.24

#### Battery protection settings

Voltage	Min. value	Default	Max. value
Cut out (0.1 steps)	VDC 32	36	60
Cut in diff. (0.1 steps)	VDC 0.5	4.0	10.0

#### Dimensions

Height	mm	A	137
		B	135
		B1	128
		B2	73
Suction connector	location/I.D. mm   angle	C	6.2   40°
	material   comment		Cu-plated steel   Al cap
Process connector	location/I.D. mm   angle	D	6.2   45°
	material   comment		Cu-plated steel   Al cap
Discharge connector	location/I.D. mm   angle	E	5.0   21°
	material   comment		Cu-plated steel   Al cap
Connector tolerance	I.D. mm		±0.09, on 5.0 +0.12/+0.20
Remarks			

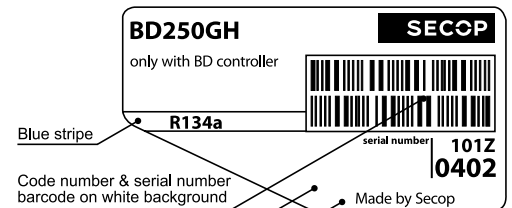

Blue stripe  
Code number & serial number barcode on white background  
Grey background  
Country of origin or manufacturer  
Made by Secop



- S = Static cooling normally sufficient
- O = Oil cooling
- F<sub>1</sub> = Fan cooling 1.5 m/s (compressor compartment temperature equal to ambient temperature)
- F<sub>2</sub> = Fan cooling 3.0 m/s necessary
- SG = Suction gas cooling normally sufficient
- = not applicable in this area

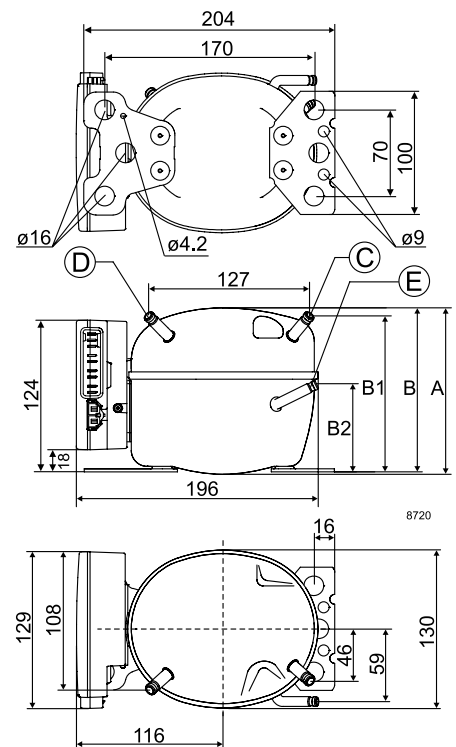

Capacity (EN 12900 Household/CECOMAF)		56V DC, static cooling										watt
rpm \ °C	-25	-23.3	-20	-15	-10	-6.7	-5	0	5	7.2	10	15
2,500	37.1	41.6	51.1	68.1	88.5	104	113	141	175	191	214	258
3,100	46.0	51.6	63.4	84.3	109	128	139	174	215	234	262	316
3,800	55.4	62.2	76.6	102	132	154	167	208	257	280	312	377*
4,400	62.9	70.7	87.1	116	149	175	189	236	290	316	353	

Capacity (ASHRAE LBP)		56V DC, static cooling										watt
rpm \ °C	-25	-23.3	-20	-15	-10	-6.7	-5	0	5	7.2	10	15
2,500	45.9	51.4	63.2	84.2	110	129	140	175	217	238	266	321
3,100	56.9	63.8	78.5	104	135	159	172	215	266	291	325	393
3,800	68.7	77.1	94.8	126	163	191	207	258	318	348	388	468*
4,400	78.0	87.6	108	143	185	216	234	292	360	393	438	

Power consumption		56V DC, static cooling										watt
rpm \ °C	-25	-23.3	-20	-15	-10	-6.7	-5	0	5	7.2	10	15
2,500	39.6	41.8	46.1	53.1	60.4	65.3	67.9	75.4	82.8	86.0	89.9	96.7
3,100	48.8	51.5	57.0	65.7	74.9	81.3	84.6	95	105	110	116	128
3,800	60.5	63.9	70.8	81.6	93	101	105	119	133	140	149	166*
4,400	70.0	74.0	82.0	94.4	108	117	122	138	155	163	174	

Current consumption		56V DC, static cooling										A
rpm \ °C	-25	-23.3	-20	-15	-10	-6.7	-5	0	5	7.2	10	15
2,500	0.71	0.75	0.82	0.95	1.08	1.17	1.21	1.35	1.48	1.53	1.61	1.73
3,100	0.87	0.92	1.02	1.17	1.34	1.45	1.51	1.69	1.88	1.97	2.08	2.28
3,800	1.08	1.14	1.26	1.46	1.66	1.80	1.88	2.12	2.37	2.49	2.65	2.96*
4,400	1.25	1.32	1.46	1.69	1.92	2.09	2.18	2.46	2.77	2.92	3.11	

COP (EN 12900 Household/CECOMAF)		56V DC, static cooling										W/W
rpm \ °C	-25	-23.3	-20	-15	-10	-6.7	-5	0	5	7.2	10	15
2,500	0.94	1.00	1.11	1.28	1.46	1.59	1.66	1.88	2.11	2.23	2.38	2.67
3,100	0.94	1.00	1.11	1.28	1.46	1.58	1.64	1.84	2.04	2.13	2.25	2.47
3,800	0.92	0.97	1.08	1.25	1.41	1.53	1.59	1.76	1.93	2.01	2.10	2.27*
4,400	0.90	0.95	1.06	1.22	1.39	1.50	1.55	1.71	1.87	1.94	2.02	

COP (ASHRAE LBP)		56V DC, static cooling										W/W
rpm \ °C	-25	-23.3	-20	-15	-10	-6.7	-5	0	5	7.2	10	15
2,500	1.16	1.23	1.37	1.59	1.82	1.98	2.07	2.34	2.64	2.78	2.97	3.35
3,100	1.17	1.24	1.38	1.59	1.81	1.96	2.04	2.28	2.54	2.66	2.81	3.09
3,800	1.13	1.21	1.34	1.55	1.76	1.90	1.97	2.19	2.41	2.50	2.62	2.84*
4,400	1.11	1.18	1.32	1.52	1.72	1.86	1.93	2.13	2.33	2.42	2.52	

\* voltage > 51V DC

Test conditions	EN 12900/CECOMAF	ASHRAE LBP
Condensing temperature	55°C	54.4°C
Ambient temperature	32°C	32°C
Suction gas temperature	32°C	32°C
Liquid temperature	no subcooling	32°C

Error code	Error type
	Can be read out in the software TOOL4COOL®
6	<b>Thermostat failure</b> (If the NTC thermistor is short-circuit or has no connection, the electronic unit will enter manual mode).
5	<b>Thermal cut-out of electronic unit</b> (If the refrigeration system has been too heavily loaded, or if the ambient temperature is high, the electronic unit will run too hot).
4	<b>Minimum motor speed error</b> (If the refrigeration system is too heavily loaded, the motor cannot maintain minimum speed at approximately 1,850 rpm).
3	<b>Motor start error</b> (The rotor is blocked or the differential pressure in the refrigeration system is too high).
2	<b>Fan over-current cut-out</b> (The fan loads the electronic unit with more than 1.8A <sub>peak</sub> ).
1	<b>Battery protection cut-out</b> (The voltage is outside the cut-out setting).

#### Accessories for BD250GH

Mounting		Code number
Bolt joint for one compressor	Ø: 16 mm	118-1917
Bolt joint in quantities	Ø: 16 mm	118-1918
Snap-on in quantities	Ø: 16 mm	118-1919

Electrical (cables, sensors, etc.)	Code number	
	Single pack	I - Pack
DC line cord, 900 mm	105N9542	105N9543, 36 pcs.
DC line cord, 2000 mm	105N9540	105N9541, 36 pcs.
DC line cord, 5000 mm	105N9538	105N9539, 36 pcs.
Temperature sensor 470 mm	105N9612	105N9613, 200 pcs.
Temperature sensor 1000 mm	105N9614	105N9615, 100 pcs.
Temperature sensor 1500 mm	105N9616	105N9617, 100 pcs.
One Wire/LIN gateway	105N9501	-
Comm. cable, 1500 mm	-	105N9545, 100 pcs.
Comm. cable, 3000 mm	-	105N9547, 50 pcs.

Not deliverable from Secop	
Slow-blow fuse	16A
Main switch	rated to min. 25A

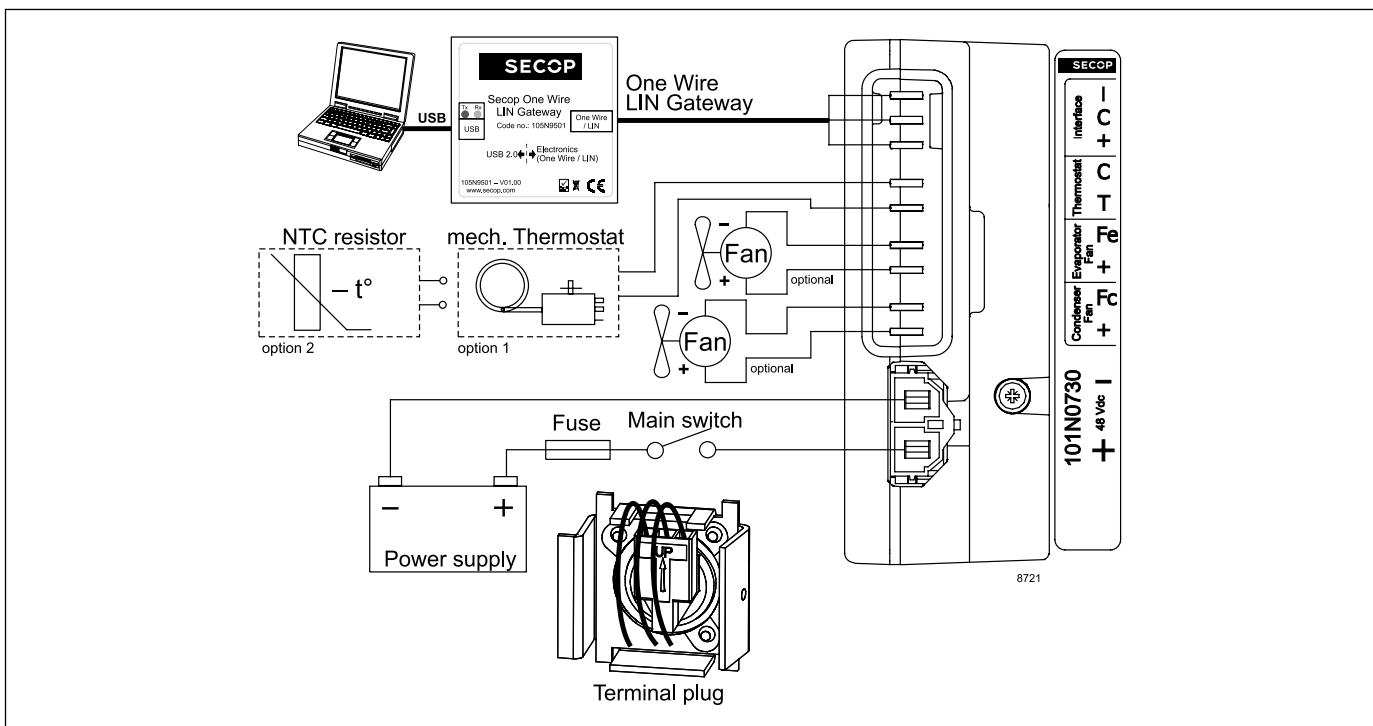

Danfoss can accept no responsibility for possible errors in catalogues, brochures and other printed material. Danfoss reserves the right to alter its products without notice. This also applies to products already on order provided that such alterations can be made without consequential changes being necessary in specifications already agreed. All trademarks in this material are property of the respective companies. Danfoss and the Danfoss logotype are trademarks of Danfoss A/S. All rights reserved.