

ENGINEERING  
TOMORROW

*Danfoss*

Technical Information

# Series 42 4T Axial Piston Tandem Pumps

## Size 41/51

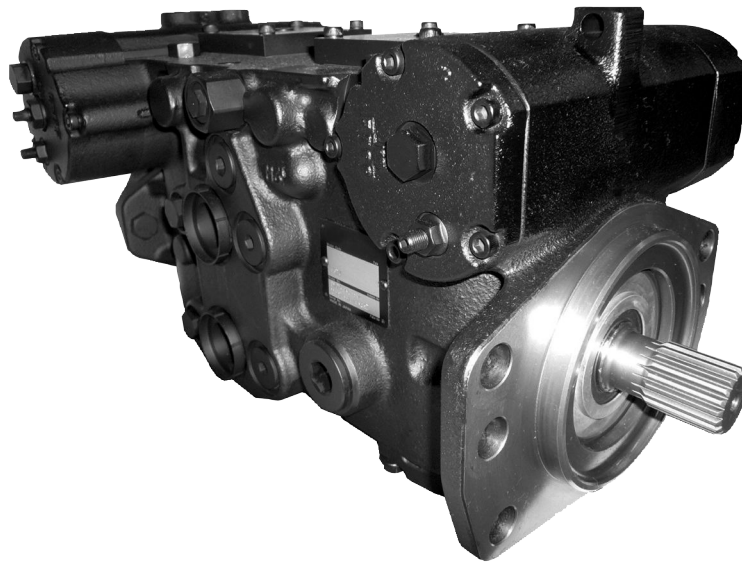

**Revision history***Table of revisions*

<b>Date</b>	<b>Changed</b>	<b>Rev</b>
May 2024	Updated shaft options	0306
April 2024	Minor correction to NFPH control	0305
April 2023	Layout adjustment	0304
March 2023	Corrected max pressure	0303
November 2020	Minor update in Hydraulic Fluid Parameters	0302
July 2020	Changed document number from 'BC00000036' to 'BC152886482857'	0301
December 2018	Corrected technical data in System Parameters	0201
June 2016	converted to new layout	0101
May 2015	Converted to DITA CMS	BA
February 2008	Corrections-Drawings	AB
January 2008	First edition	AA

## Contents

### General Description

Basic Design.....	5
System Diagram.....	6
System Schematic.....	7

### Technical Specifications

System Specifications.....	9
System Parameters.....	9
Hydraulic Fluid Parameters.....	10

### Operating Parameters

System Requirements.....	11
System Parameters.....	11
Hydraulic Fluid Parameters.....	12
Sizing Equations.....	13

### System Design Parameters

Fluid and Filtration.....	14
Filtration Configuration.....	14
Mounting Flange Loads.....	15
Estimating Overhung Load Moment.....	15
Case Drain.....	16
External Shaft Load and Bearing Life.....	16
Hydraulic Unit Life.....	17
Efficiency Graphs.....	18

### Features and Options

Charge Pump.....	19
Charge Pump Sizing Example.....	19
Charge Relief Valve.....	19
Overpressure Protection.....	20
Bypass Valve.....	21
Displacement Limiters.....	21
Shaft Options.....	21
Auxiliary Mounting Pads.....	22
Center Coupling.....	23
Control Selection.....	23
Manual Displacement Control (MDC).....	25
Features and Benefit of MDC.....	25
Control Input Signal.....	26
Response Time.....	26
Control Handles.....	27
Electric Solenoid Override to Neutral.....	27
Emergency Override to Neutral with Port for Brake Pressure Release.....	28
Neutral Start Switch (NSS).....	29
NSS with Back-up Alarm (BUA) Switch.....	29
Connectors.....	29
Non-feedback, proportional hydraulic control (NFPH).....	31
Features and Benefits of the NFPH control.....	32
Connectors and Port locations.....	32

### Installation Drawings

Manual Displacement Control (MDC).....	33
Port Description.....	33
Dimensions.....	35
Non-Feedback, Proportional Hydraulic (NFPH).....	38
Port Description.....	38
Dimensions.....	40
Shaft Options.....	43
Displacement Limiter.....	44
By-pass Valve.....	45

**Contents**

Control Modules.....45  
Auxiliary Mounting Pads..... 47

**Model Code**

Model Code: A, Y, Z.....49  
Model Code: FD, FX, RD, RX..... 50  
Model Code: FE, RE..... 51  
Model Code: FT, RT, FH, RH, FJ, RJ, FK, RK..... 52  
Model Code: FL, RL, FM, RM..... 53  
Model Code: C, F, S..... 55  
Model Code: U, G, V..... 56  
Model Code: N, P..... 57

## General Description

### Basic Design

S42 Integrated Tandem Pumps (4T) are advanced hydrostatic units for medium power applications with maximum loads of 415 Bar [6020 psi] (41 cm<sup>3</sup>) and 350 Bar [5075 psi] (51 cm<sup>3</sup>). You can combine these pumps with a suitable Danfoss motor or other products in a system to transfer and control hydraulic power.

The 4T axial piston pump is a compact, high power density unit, using the parallel axial piston/slider concept in conjunction with tiltable swashplates to vary the pumps' displacements.

Reversing the angle of the swashplate reverses the flow of fluid from the pump, and reversing the direction of rotation of the motor output. 4T axial piston pumps provide an infinitely variable speed range between zero and maximum in both forward and reverse.

4T axial piston pumps use a cradle swashplate design with a hydraulic servo control cylinder. Control is provided through a compact servo control system. Two types of servo controls are available. These include mechanical hydraulic actuated feedback controls, and hydraulic proportional control. These controls feature low hysteresis and responsive performance.

### Cross-sectional view

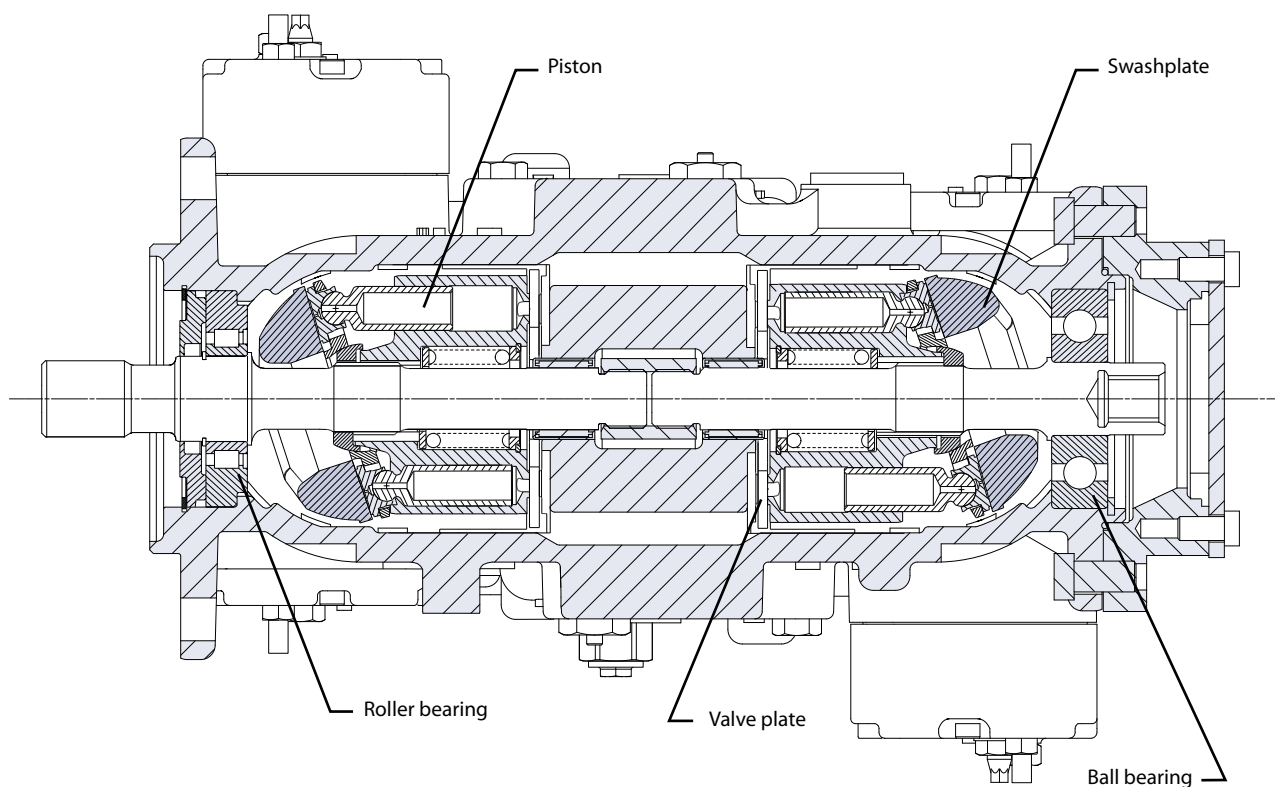

P400160

**General Description**

**System Diagram**

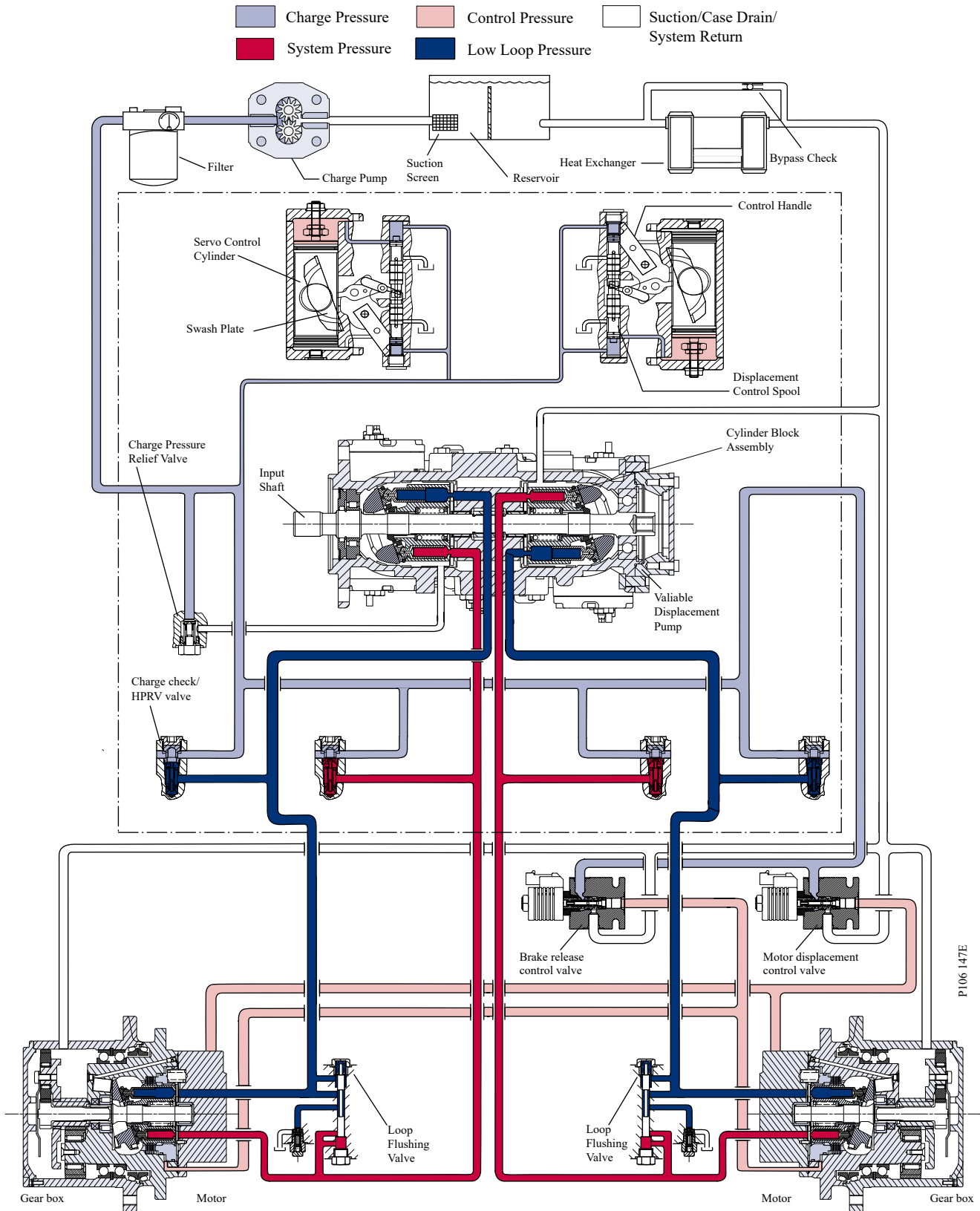

P106 147E

## General Description

### System Schematic

#### 4T Axial Piston Pump

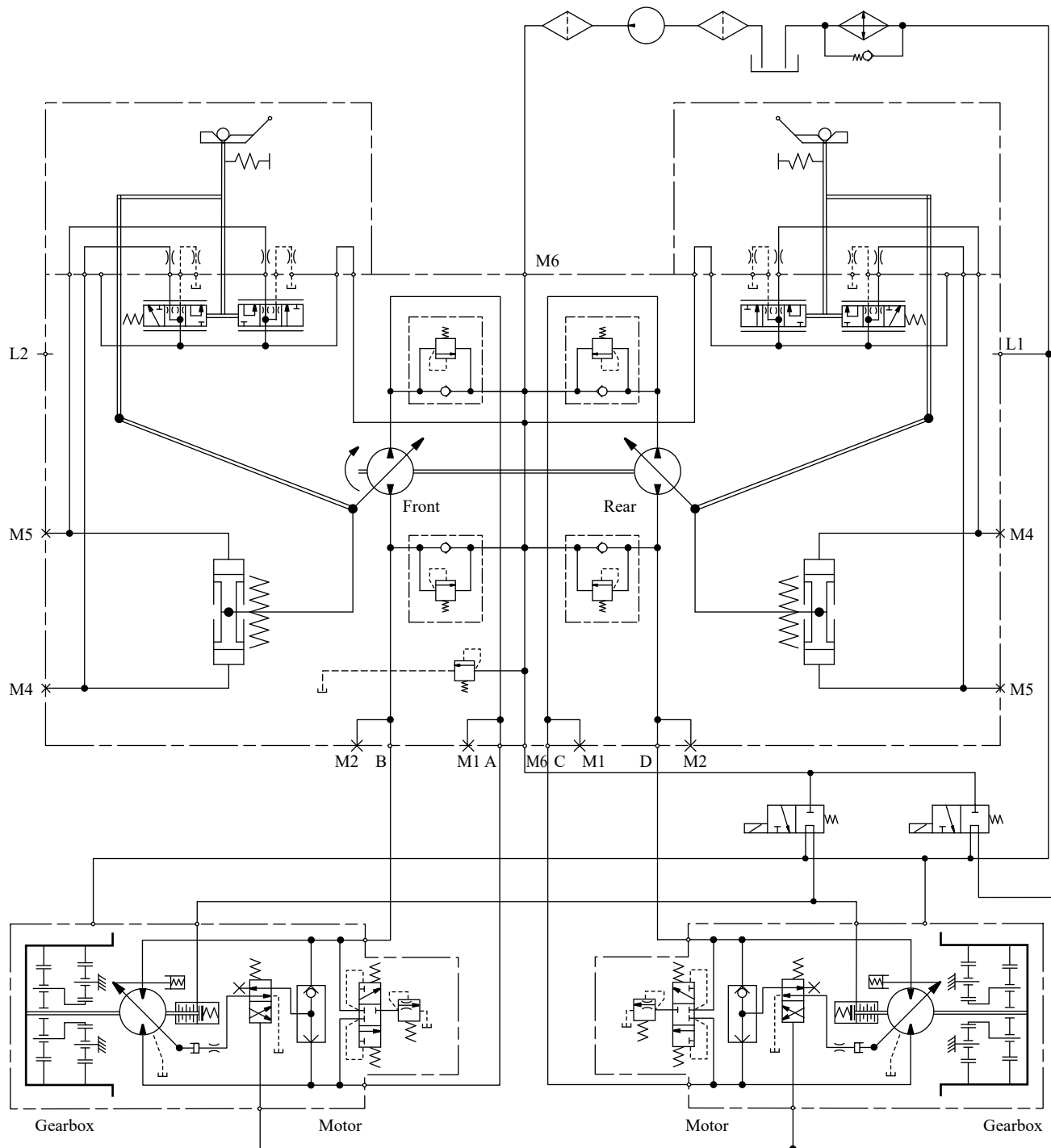

P400161

The illustration above shows a schematic of a 4T axial piston pump. System ports A, C and B, D connect to the high pressure work lines. Return fluid is received from its inlet port and discharged through the outlet port. Flow direction is determined by swashplate position. You can read system port pressure through ports M1 and M2. The pump has two case drains (L1 and L2) to ensure there is lubricating fluid in the

## General Description

system. This schematic includes a manual displacement control. For other control schematics see the related control section: [Manual Displacement Control \(MDC\)](#) on page 25, [Non-feedback, proportional hydraulic control \(NFPH\)](#)



## Technical Specifications

### System Specifications

#### General Specifications

Feature	Series 42 4T
<b>Pump type</b>	In-line, axial piston, positive displacement pumps including cradle swashplate and servo control
<b>Direction of input rotation</b>	Clockwise or counterclockwise
<b>Recommended installation position</b>	Pump installation recommended with control position on the top or side. Consult Danfoss for non conformance guidelines. The housing must always be filled with hydraulic fluid.
<b>Other system requirements</b>	Independent braking system, suitable reservoir and heat exchanger.

#### Hardware Features

<b>Pump configuration</b>	Single variable pump		
<b>Displacement</b>	cm <sup>3</sup> [in <sup>3</sup> ]	40.9 [2.50] x 2	51 [3.11] x 2
<b>Weight</b>	kgf [lbf]	MDC: 76 [168] NFPH: 72 [158]	
<b>Mass moment of inertia</b>	kg·m <sup>2</sup> [lbf·ft <sup>2</sup> ]	0.0072 [0.0054]	0.0076 [0.0056]
<b>Type of front mounting flange</b> (SAE flange size per SAE J744)	2 Bolt SAE C (4 additional bolt holes available)		
<b>Port connections</b>	SAE-twin ports, radial, opposite side ports		
<b>System pressure regulation</b>	bar [psi]	210-415 [3045-6020]	210-325 [3045-4715]
<b>Displacement limiters</b>	Option		
<b>Input shaft options</b>	Splined		
<b>Auxiliary mounting pad</b> (SAE pad per SAE J744)	SAE A (9 tooth, 11 tooth and 13 tooth) SAE B (13 tooth)		
<b>Control options</b>	MDC, NFPH		
<b>Loop flushing</b>	None		

### System Parameters

#### Case pressure

<b>Continuous pressure</b>	bar [psi]	3 [44]
<b>Maximum pressure (cold start)</b>	bar [psi]	10.3 [150]

#### Pressure Limits

<b>Displacement</b>	cm <sup>3</sup>	<b>41</b>	<b>51</b>
<b>Rated pressure</b>	bar [psi]	350 [5075]	325 [4713]
<b>Maximum pressure</b>	bar [psi]	415 [6017]	350 [5075]

## Technical Specifications

### Speed Limits

<b>Frame size</b>	cm <sup>3</sup>	<b>41</b>	<b>51</b>
<b>Minimum speed</b>	min <sup>-1</sup> (rpm)	500	
<b>Rated speed at maximum displacement</b>	min <sup>-1</sup> (rpm)	3200	2900
<b>Maximum speed at maximum displacement</b>	min <sup>-1</sup> (rpm)	3450	3400

### Charge Pump Displacement and Setting Pressure

<b>Frame size</b>		cm <sup>3</sup>	<b>41</b>	<b>51</b>
<b>Internal</b>	-	cm <sup>3</sup> /rev [in <sup>3</sup> /rev]	none	none
<b>Charge relief valve settings</b>	<b>Standard</b>	bar	20 [290]	
	<b>Optional</b>	[psi]	14-24 [203-340]	

### Theoretical Flow

<b>Frame size</b>	cm <sup>3</sup>	<b>41</b>	<b>51</b>
<b>Theoretical flow at rated speed</b>	l/min [US gal/ min]	131 [34.6]	148 [39.1]

### Check/high Pressure Relief Valve

<b>Options</b>	bar [psi]	No relief valve /check only	Relief valve / check
<b>Setting</b>		—	210-415 [3045-6020] or by setting available 210, 250, 280, 300, 325, 345, 360, 385, 415

## Hydraulic Fluid Parameters

### Fluid temperature range

<b>Minimum</b>	-40 °C [-40 °F]	Intermittent, cold start
<b>Maximum continuous</b>	104 °C [220 °F]	-
<b>Maximum</b>	115 °C [240 °F]	Intermittent

### Fluid cleanliness level

<b>Required fluid cleanliness level</b>	ISO 4406 Class 22/18/13
---	-------------------------

### Fluid viscosity

<b>Minimum</b>	7.0 mm <sup>2</sup> /s (cSt)	Intermittent
<b>Recommended operating range</b>	12-60 mm <sup>2</sup> /s (cSt)	-
<b>Maximum</b>	1600 mm <sup>2</sup> /s (cSt)	Intermittent, cold start

## Operating Parameters

### System Requirements

#### Independent braking system

##### **Warning**

**Unintended vehicle or machine movement hazard.** The loss of hydrostatic drive line power, in any mode of operation (forward, neutral, or reverse) may cause the system to lose hydrostatic braking capacity. You must provide a braking system, redundant to the hydrostatic transmission, sufficient to stop and hold the vehicle or machine in the event of hydrostatic drive power loss.

---

#### Reservoir

Design the system to accommodate maximum volume changes during all system operating modes and to promote de-aeration of the fluid as it passes through the tank. Minimum reservoir volume is 5/8 of the maximum charge pump flow per minute with a minimum fluid volume equal to 1/2 of the maximum charge pump flow per minute. At the maximum return flow, this allows 30 seconds fluid dwell for removing entrained air. This is adequate for a closed reservoir (no breather) in most applications. Position the reservoir outlet (pump inlet) above the bottom of the reservoir to take advantage of gravity separation and prevent large foreign particles from entering the charge inlet line. Use a 100 - 125 µm screen over the outlet port. Position the reservoir inlet (fluid return) so that flow to the reservoir is discharged below the normal fluid level, and directed into the interior of the reservoir for maximum dwell and efficient de-aeration. Use a baffle (or baffles) between the inlet and outlet ports to promote de-aeration and reduce surging of the fluid.

### System Parameters

#### Speed limits

Rated speed is the speed limit we recommend at full power condition and is the highest value at which you can expect normal life. Maximum speed is the highest operating speed we permit. You cannot operate above this speed without risk of immediate failure and loss of drive line power and hydrostatic braking capacity (which may create a hazard). In mobile applications, you must apply this pump with a speed below the stated maximum. Consult *Pressure and Speed Limits*, BC152886484313, when determining speed limits for a particular application.

#### Inlet pressure

Control charge pump inlet conditions to achieve expected life and performance. Ensure a continuous inlet pressure of not less than 0.8 bar absolute (not more than 6 in Hg vacuum). Normal pressures less than 0.7 bar absolute (greater than 9 in Hg vacuum) indicate inadequate inlet design or a restricted filter. Pressures less than 0.7 bar absolute (greater than 9 in Hg vac) during cold start are possible, but should improve quickly as the fluid warms. Never exceed the maximum inlet vacuum.

#### Theoretical output

The theoretical maximum flow at rated speed is a simple function of pump displacement and speed. This is a good gauge for sizing a companion motor. This does not take into account losses due to leakage or variations in displacement.

#### Case pressure

Under normal operating conditions, the **rated case pressure** must not be exceeded. During cold start case pressure must be kept below maximum intermittent case pressure. Size drain plumbing accordingly.

## Operating Parameters

### System pressure

**System pressure** is the differential pressure between high pressure system ports. It is the dominant operating variable affecting hydraulic unit life. High system pressure, which results from high load, reduces expected life. Hydraulic unit life depends on the speed and normal operating, or weighted average, pressure that can only be determined from a duty cycle analysis.

**Application pressure** - is the high pressure relief or pressure limiter setting normally defined within the order code of the pump. This is the applied system pressure at which the driveline generates the maximum calculated pull or torque in the application. **Maximum Working Pressure** - is the highest recommended Application pressure.

**Maximum working pressure** is not intended to be a continuous pressure. Propel systems with Application pressures at, or below, this pressure should yield satisfactory unit life given proper component sizing.

**Maximum pressure** is the highest allowable Application pressure under any circumstance. Application pressures above Maximum Working Pressure will only be considered with duty cycle analysis and factory approval.

**Minimum pressure** must be maintained under all operating conditions to avoid cavitation.

### Warning

---

All pressure limits are differential pressures referenced to low loop (charge) pressure. Subtract low loop pressure from gauge readings to compute the differential.

---

## Hydraulic Fluid Parameters

### Hydraulic fluid

Ratings and data are based on operating with hydraulic fluids containing inhibitors to prevent oxidation, rust, and foam. These fluids must possess good thermal and hydrolytic stability to prevent wear, erosion, and corrosion of the internal components.

### Caution

---

Never mix hydraulic fluids of different types.

---

### Temperature and viscosity

Ensure the application satisfies temperature and viscosity requirements concurrently. The data shown in the tables on [Hydraulic Fluid Parameters](#) on page 10, assume petroleum-based fluids.

High temperature limits apply at the hottest point in the transmission, which is normally the case drain. Always run the pump at or below the continuous temperature. Never exceed maximum temperature.

Durability of transmission components is not affected by cold oil, but it may affect the ability of oil to flow and transmit power. Keep temperatures 16 °C [30 °F] above the pour point of the hydraulic fluid. The minimum temperature relates to physical properties of component materials.

For maximum unit efficiency and bearing life, keep fluid viscosity in the continuous viscosity range. During brief occasions of maximum ambient temperature and severe duty cycle operation, minimum viscosity may occur. The system should encounter maximum viscosity only at cold start.

Size heat exchangers to keep the fluid temperature and viscosity within these limits. Test the system to verify that these temperature limits are not exceeded.

## Operating Parameters

### Sizing Equations

Use these equations to help choose the right pump size and displacement for your application.

#### Based on SI units

**Flow** Output flow  $Q = \frac{V_g \cdot n \cdot \eta_v}{1000}$  (l/min)

**Torque** Input torque  $M = \frac{V_g \cdot \Delta p}{20 \cdot \pi \cdot \eta_m}$  (N·m)

**Power** Input power  $P = \frac{M \cdot n \cdot \pi}{30\,000} = \frac{Q \cdot \Delta p}{600 \cdot \eta_t}$  (kW)

#### Based on US units

Output flow  $Q = \frac{V_g \cdot n \cdot \eta_v}{231}$  (US gal/min)

Input torque  $M = \frac{V_g \cdot \Delta p}{2 \cdot \pi \cdot \eta_m}$  (lbf·in)

Input power  $P = \frac{M \cdot n \cdot \pi}{198\,000} = \frac{Q \cdot \Delta p}{1714 \cdot \eta_t}$  (hp)

### Variables

SI units [US units]

**$V_g$**  = Displacement per revolution  $\text{cm}^3/\text{rev}$  [ $\text{in}^3/\text{rev}$ ]

**$P_o$**  = Outlet pressure bar [psi]

**$P_i$**  = Inlet pressure bar [psi]

**$\Delta p$**  =  $p_o - p_i$  (system pressure) bar [psi]

**$n$**  = Speed  $\text{min}^{-1}$  (rpm)

**$\eta_v$**  = Volumetric efficiency

**$\eta_m$**  = Mechanical efficiency

**$\eta_t$**  = Overall efficiency ( $\eta_v \cdot \eta_m$ )

## System Design Parameters

### Fluid and Filtration

To prevent premature wear, use only new clean fluid. Use a filter capable of controlling fluid cleanliness to ISO 4406 Class 22/18/13 (SAE J1165).

Locate the filter on the inlet (suction filtration) or discharge (charge pressure filtration) side of the charge pump: 4T axial piston pumps are available with provisions for either configuration.

The selection of a filter depends on a number of factors including the contaminant ingress rate, the generation of contaminants in the system, the required fluid cleanliness, and the desired maintenance interval. Use filters that meet the above requirements of efficiency and capacity.

Filter efficiency can be measured with a Beta ratio ( $\beta_x$ ). For simple suction-filtered closed circuit transmissions and open circuit transmissions with return line filtration, a filter with a  $\beta$ -ratio within the range of  $\beta_{35-45} = 75$  ( $\beta_{10} \geq 2$ ) or better has been found to be satisfactory. For some open circuit systems, and closed circuits with cylinders being supplied from the same reservoir, a higher filter efficiency is recommended. This also applies to systems with gears or clutches using a common reservoir. For these systems, a charge pressure or return filtration system with a filter  $\beta$ -ratio in the range of  $\beta_{15-20} = 75$  ( $\beta_{10} \geq 10$ ) or better is typically required.

Because each system is unique, only a thorough testing and evaluation program can fully validate the filtration system. Please see *Design Guidelines for Hydraulic Fluid Cleanliness*, BC152886482150, Technical Information for more information.

### Filtration Configuration

Locate the filter on the inlet (Suction filtration) or discharge (Charge pressure filtration) side of the external charge pump.

#### Suction filtration

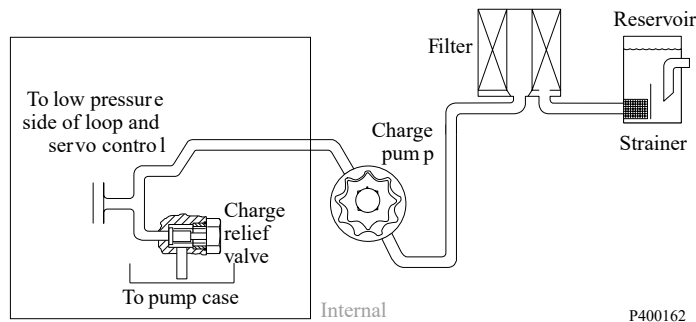

#### Charge pressure filtration, full flow

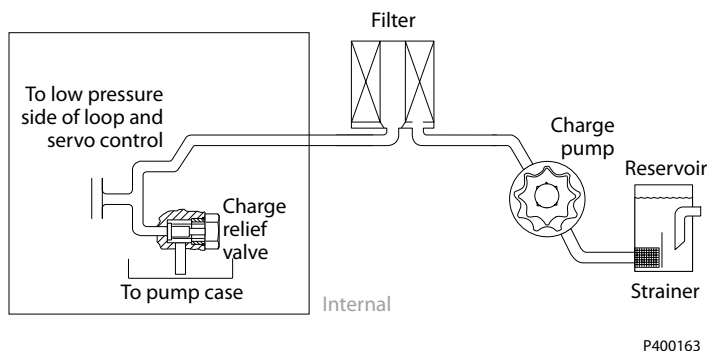

## System Design Parameters

### Mounting Flange Loads

Adding tandem mounted auxiliary pumps and/or subjecting pumps to high shock loads may result in excessive loading of the mounting flange. Design pump applications to stay within the allowable shock load and continuous load moments.

Shock load moment  $M_S$  is the result of an instantaneous jolt to the system. Rated (continuous) load moments  $M_R$  are generated by the typical vibratory movement of the application.

Estimated maximum and continuous acceleration factors for some typical applications are shown in the table.

Applications which experience extreme resonant vibrations may require additional pump support. Exceeding the allowable overhung values listed below will require additional pump support.

*G-factors for sample applications*

Application	Continuous (vibratory) acceleration ( $G_R$ )	Maximum (shock) acceleration ( $G_S$ )
Skid steer loader	4	10
Trencher (rubber tires)	3	8
Asphalt paver	2	6
Windrower	2	5
Turf care vehicle	1.5	4
Vibratory roller	6	10

*Allowable overhung load moments*

Rated load moment ( $M_R$ )	Shock load moment ( $M_S$ )
1441 N·m [12750 in·lbf]	3413 N·m [30200 in·lbf]

### Estimating Overhung Load Moment

$$M_R = G_R (W_1 L_1 + W_2 L_2 + \dots + W_n L_n)$$

$$M_S = G_S (W_1 L_1 + W_2 L_2 + \dots + W_n L_n)$$

Where:

- $M_R$**  Rated load moment N·m [lbf·in]
- $M_S$**  Shock load moment N·m [lbf·in]
- $G_R$**  Rated (vibratory) acceleration (G-factors: unitless)
- $G_S$**  Maximum shock acceleration (G-factors: unitless)
- $W$**  Weight of the pump N [lbf]
- $L$**  Distance from mounting flange to the center of gravity mm [in]

## System Design Parameters

### Overhung load moments

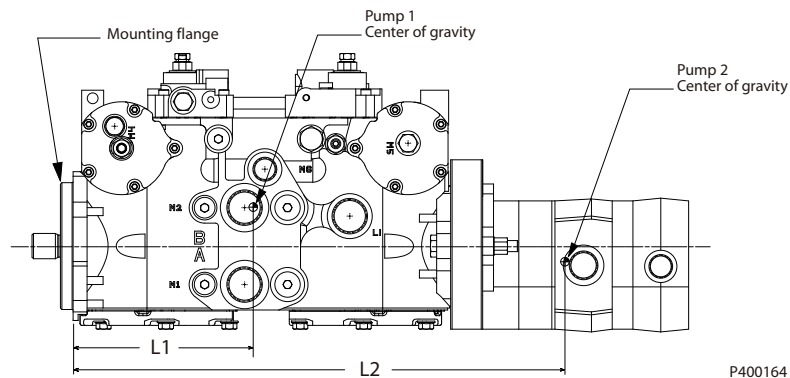

P400164

## Case Drain

The front and rear pumps are connected by cast passages in the housing. The charge relief valve discharges oil into the front housing. In order to provide positive housing flow thru both pumps, use of rear case drain is required. The front case drain should only be used if the pumps are used as a common drain manifold for the vehicle whereas external drain flow is brought into the rear case port and discharged out the front.

## External Shaft Load and Bearing Life

Bearing life is a function of speed, pressure, and swashplate angle, plus any external loads. Other factors that affect life include fluid type, viscosity, and cleanliness.

In vehicle propulsion drives with no external loads—where the speed, pressure, and swashplate angle are often changing—normal bearing B10 (90% survival) life exceeds the hydraulic unit life.

In non-propel drives, such as conveyors or fan drives, the operating speed and pressure may be nearly constant leading to a distinctive duty cycle compared to that of a propulsion drive. In these types of applications, we recommend a bearing life review. 4T axial piston pumps use bearings that can accept some incidental external radial and thrust loads. However, any amount of external load reduces the expected bearing life.

The allowable radial shaft loads are a function of the load position, orientation, and operating pressures of the hydraulic unit. In applications where you cannot avoid external shaft loads, minimize the impact on bearing life by orienting the load to the 0° or 180° position.

The maximum allowable radial load is calculated as:  $R_e = M_e / L$

Where:

- L** Distance from mounting flange to point of load
- $M_e$**  Maximum external moment
- $R_e$**  Maximum radial side load
- $T_{out}$**  Thrust load
- $F_B$**  Load to cylinder block kit



### System Design Parameters

*Allowable shaft loads*

Displacement (cm <sup>3</sup> )	41	51
M <sub>e</sub> N·m [in·lbf]	111 [982]	90 [800]
T <sub>OUT</sub> N [lbf]	1110 [250]	1110 [250]

Avoid thrust loads in T<sub>in</sub> direction.

If continuously applied external radial loads are 25% of the maximum allowable or more, or thrust loads are known to occur, contact your Danfoss representative for an evaluation of unit bearing life.

Use clamp-type couplings where radial shaft side loads are present.

*External shaft load orientation*

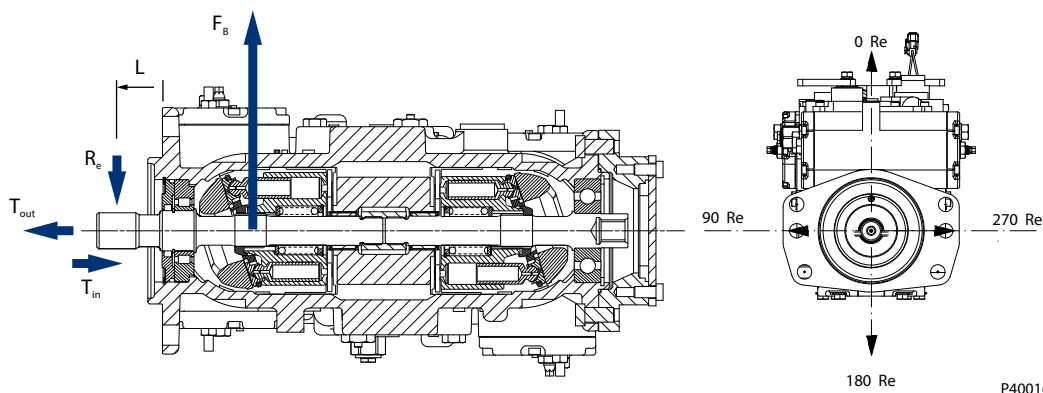

Use the table and drawing to determine maximum allowable radial loads (R<sub>e</sub>), based on the maximum external moment (M<sub>e</sub>) and the distance (L) from the mounting flange to the load.

### Hydraulic Unit Life

Hydraulic unit life is the life expectancy of the hydraulic components. Hydraulic unit life is a function of speed and system pressure. However, system pressure is the dominant operating variable. High pressure, which results from high load, reduces expected life.

Design the hydraulic system to a projected machine duty cycle. Know the expected percentages of time at various loads and speeds. Ask your Danfoss representative to calculate an appropriate pressure based your hydraulic system design. If duty cycle data is not available, input power and pump displacement are used to calculate system pressure.

All pressure limits are differential pressures (referenced to charge pressure) and assume normal charge pressure.

4T axial piston pumps will meet satisfactory life expectancy if applied within the parameters specified in this bulletin. For more detailed information on hydraulic unit life see **BC152886484313**, *Pressure and Speed Limits*.

## System Design Parameters

### Efficiency Graphs

The following performance map provides typical volumetric and overall efficiencies for 4T axial piston pumps. These efficiencies apply for all 4T axial piston pumps at maximum displacement.

*Pump performance as a function of operating speed at maximum displacement\**

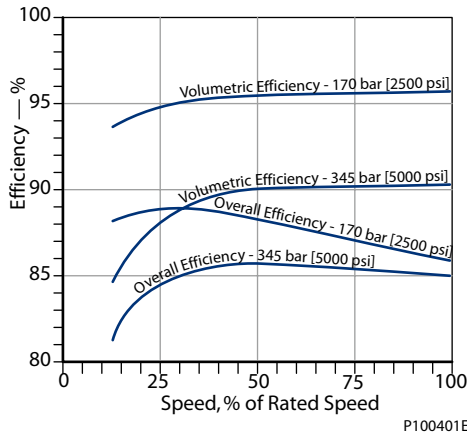

The following performance map provides typical pump overall efficiencies at various operating parameters. These efficiencies also apply for all 4T axial piston pumps at maximum displacement.

*Pump performance at select operating parameters at maximum displacement\**

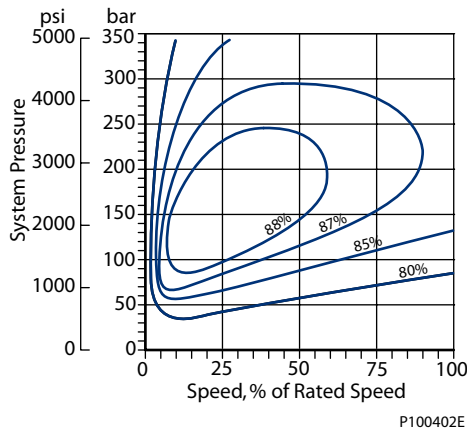

\* Assumes viscosity in the continuous range

## Features and Options

### Charge Pump

An external charge pump is required on all 4T axial piston pumps units applied in closed circuit installations to make up for internal leakage, to maintain positive pressure in the main circuit, and to replace any leakage losses from external valving or auxiliary systems.

The total charge flow requirement is the sum of the charge flow requirement of each of the components in the system. When initially sizing and selecting hydrostatic units for an applications, it is frequently not possible to have all of the information necessary to accurately evaluate all aspects of charge pump size selection. The following procedure will assist the designer in arriving at an initial charge pump selection for a typical application.

In most 4T axial piston pump applications a general guideline is that the charge pump displacement (CPG) should be equal to or greater than 10% of the total displacement (TD) of all axial piston units in the system. This rule assumes that all units are of high speed, axial piston or bent axis design.

Particular application conditions may require a more detailed review of charge pump sizing. System features and conditions that may invalidate the 10% of displacement rule include (but are not limited to):

- Operation at low input speeds (below 1500 rpm)
- Shock loadings
- Excessively long system lines
- Auxiliary flow requirements
- Use of low speed, high torque motors

If a charge pump of sufficient displacement to meet the 10% of displacement rule is not available or if any of the above conditions exist which could invalidate the 10% rule, contact your Danfoss representative.

A charge pump sizing worksheet can be found in **BC157786484430**, *Selection of Driveline Components*.

#### Charge Pump Sizing Example:

A system consists of 4T 41cc Pump driving two Series 40 -M35 Fixed Motors:

- $TD = 41 + 41 + 35 + 35 = 152 \text{ cm}^3$
- $CPD = 10 \% \times TD = 15.2 \text{ cm}^3$

This requires a charge pump displacement of  $15.2 \text{ cm}^3$ .

### Charge Relief Valve

The charge relief valve maintains charge pressure at a designated level. 4T axial piston pumps come with direct-acting poppet style charge relief valves. The valve setting is set at the factory. The setting is screw adjustable.

The charge pressure settings are nominal values and are based on the charge flow across the charge relief valve with a fluid viscosity of  $28 \text{ mm}^2/\text{s}$  (cSt) [130 SUS] and a pump input speed of  $1800 \text{ min}^{-1}$  (rpm). Actual charge pressure differs slightly from the nominal setting when different input speeds are used. The charge setting is a differential pressure (referenced to case pressure) and measured with the piston pump at zero swashplate angle (neutral). Charge pressure drops slightly when the pump is in stroke due to flow demands.

The charge pressure setting for pumps without an internal charge pump is set with an assumed charge flow of 38 l/min (10 US gal/min). These units must have adequate charge flow supplied to the charge inlet in order to maintain charge pressure at all times.

## Features and Options

Charge Relief Valve

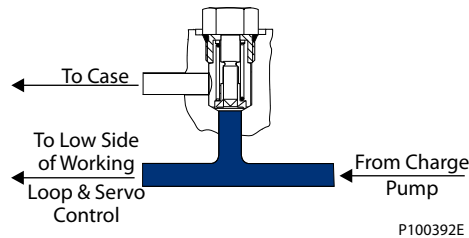

**! Caution**

Incorrect charge pressure settings may result in the inability to build required system pressure, inability to control pump, and/or inadequate loop flushing flows. Maintain correct charge pressure under all operating conditions.

## Overpressure Protection

4T axial piston pumps are available with a combination charge check and high pressure relief valve assembly. High pressure relief valves come in a range of settings as shown in the model code. You may specify individual port pressure settings. The high pressure relief valve settings are a differential pressure (referenced to charge pressure) and are set at 3.8 l/min (1 US gal/min) of flow.

We can equip pumps with charge check valves only, if high pressure relief valve protection is not necessary.

Charge Check and High Pressure Relief Valve

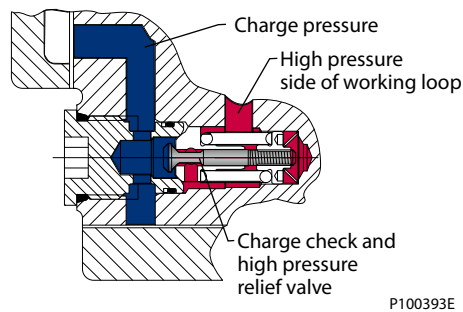

**! Caution**

High pressure relief valves are for transient overpressure protection, not for continuous pressure control. Operation over relief valves for extended periods of time results in severe heat build up. High flows over relief valves may result in pressure levels exceeding the nominal valve setting and potential damage to system components.

## Features and Options

### Bypass Valve

4T axial piston pumps are available with an optional bypass function for use when pump shaft rotation is not possible. Use the bypass function to bypass fluid around the variable displacement pump. For example: you may move a disabled vehicle to a service location or winch it onto a trailer without operating the prime mover.

The bypass valve is integral to the charge check/high pressure relief valve assembly. Depress the plungers located in the plugs of the valve assemblies to operate the bypass function. The valves remain open until the prime mover is started. Charge pressure automatically closes them.

#### Charge Check and High Pressure Relief Valve with Bypass

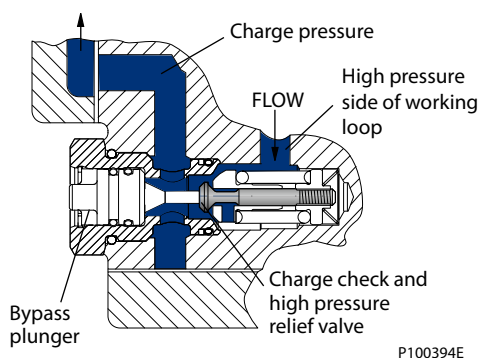

#### Caution

Damage to the hydraulic system may result from operating without charge flow. Bypass valves are for moving a machine or vehicle for very short distances at very slow speeds. They are NOT tow valves.

### Displacement Limiters

4T axial piston pumps are available with adjustable mechanical displacement (stroke) limiters located in the servo covers. The maximum displacement of the pump can be limited to any value from its maximum displacement to zero in either direction. The limiters are factory set slightly beyond the maximum displacement of the pump. Displacement limiters may not be suited to all applications.

#### Series 42 pump displacement limiters

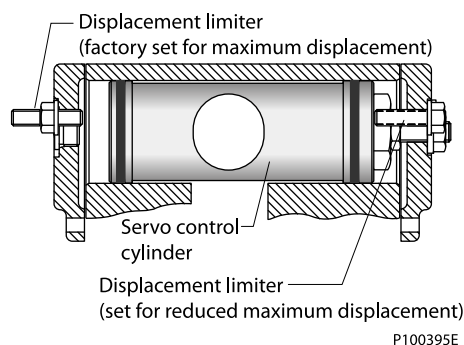

### Shaft Options

4T axial piston pumps are available with a variety of splined and tapered shaft ends. The accompanying table shows available shaft sizes and torque ratings. Maximum torque ratings are based on shaft torsional strength and assume a maximum of 200 000 load reversals.

## Features and Options

Use ANSI B92.1 Class 5 mating splines for splined output shafts. Danfoss external splines are modified Class 5 fillet root side fit. The external spline major diameter and circular tooth thickness dimensions are reduced in order to insure a clearance fit with the mating spline.

### Shaft Availability and Torque Rating\*

Shaft	Max. torque
15 tooth spline, 16/32 pitch	362 N•m [3200 in•lbf]
19 tooth spline, 16/32 pitch	734 N•m [6500 in•lbf]

\* The limitations of these input shafts constrain the allowable auxiliary coupling torque.

## Auxiliary Mounting Pads

Auxiliary mounting pads are available on all 4T axial piston pumps to mount auxiliary hydraulic pumps. We include a sealed (oil tight) shipping cover as standard equipment. The shipping cover seals case pressure and you can use it as a running cover if desired.

Since the auxiliary mounting pad operates under case pressure, you must use an O-ring to seal the auxiliary pump to the pad. The drive coupling is lubricated with oil from the main pump case.

Spline specifications and torque ratings are shown in the accompanying table.

- All mounting pads meet SAE J744 specifications.
- The sum of main and auxiliary pump torque must not exceed stated maximum.
- All torque values assume a 58  $R_C$  shaft spline hardness on mating pump shaft. Maximum torque is based on maximum torsional strength and 200 000 load reversals.
- Applications with severe vibratory or high G-force (shock) loading may require additional structural support to prevent leaks or mounting flange damage. Refer to [Mounting flange loads](#) for additional information.

### Auxiliary Pad\*

Pad size	Spline	Minimum spline length (mm [in])	Maximum torque (N•m [lbf-in])
SAE A	9 tooth 16/32 pitch	13.5 [0.53]	107 [950]
SAE A special	11 tooth 16/32 pitch	13.5 [0.53]	147 [1300]
SAE A special	13 tooth 16/32 pitch	14.2 [0.56]	248 [2200]
SAE B	13 tooth 16/32 pitch	14.2 [0.56]	248 [2200]

\* Allowable Auxiliary coupling torque is subject to limitations of the input shaft.

This drawing provides the dimensions for the auxiliary pump mounting flange and shaft. Auxiliary pump mounting flanges and shafts with these dimensions are compatible with the auxiliary mounting pads on 4T axial piston pumps. For auxiliary pad dimensions, see [Auxiliary Mounting Pads](#) on page 47.

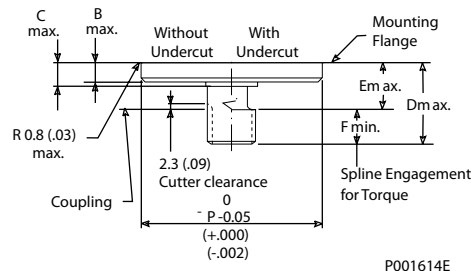

## Features and Options

### Auxiliary pump mating dimensions

Pad Size	P	B	C	D	E	F
SAE A mm [in]	82.55 [3.250]	8.1 [0.32]	12.7 [0.500]	44 [1.73]	15 [0.59]	13.5 [0.53]
SAE B mm [in]	101.6 [4.000]	11.4 [0.45]	15.2 [0.60]	46 [1.81]	17.5 [0.69]	14.2 [0.56]

## Center Coupling

The two pump shafts are connected with a center-section coupling that is a 22 tooth spline with a 24/48 pitch. The torque transmitted through the center coupling is the sum of the rear kit torque and the auxiliary pump torque. The maximum torque rating of the auxiliary pad may be reduced from the values in the above table due to center coupling limitations.

### 22 tooth Center-Section Coupling Torque Rating

Rating	Torque in N·m [lbf·in] 22T
<b>Maximum</b>	347 [3071]
<b>Continuous</b>	243 [2151]

## Control Selection

4T axial piston pumps use a servo control system with two types of control options. Manual Displacement Controls (MDC) are feedback controls that provide and maintain a set displacement for a given input. The MDC includes options for a Neutral Start Switch (NSS), backup alarm, and a solenoid override to neutral. Non-Feedback Proportional Hydraulic controls (NFPH) is available to control the pump without mechanical feedback.

All controls provide smooth, stepless positive control of the transmission in either direction. Optional servo supply and drain orifices are available for special response needs.

### Typical Control Applications

Machine	Function	MDC	NFPH
Roller/compactor	Propel	●	●
	Vibratory drive	●	
Asphalt paver	Propel	●	
Skid steer loader	Propel	●	●
Articulated loader	Propel		●
Utility tractor	Propel	●	●
Windrower	Propel	●	
Trencher	Propel	●	●
	Chain drive	●	
Ag sprayer	Propel	●	
Specialized harvesters (sod, fruit, nut, etc.)	Propel	●	●
	Auxiliary drive	●	
Commercial mower	Propel	●	●
Rock drill	Propel	●	
Drill rig	Drill drive		●
	Pull downe		●
Sweeper	Propel	●	●
	Fan	●	

**Features and Options**

*Typical Control Applications (continued)*

<b>Machine</b>	<b>Function</b>	<b>MDC</b>	<b>NFPH</b>
Aerial lift	Propel		
Fork lift	Propel		●
Brush / stump cutter	Propel	●	●
	Cutter drive	●	
Airport vehicle	Propel		●
Dumper	Propel	●	●



## Features and Options

### Manual Displacement Control (MDC)

The Manual Displacement Control (MDC) converts a mechanical input signal to a hydraulic signal. The hydraulic signal positions the servo piston, tilting the swashplate to vary the pump's displacement and flow direction.

The position of the swashplate is proportional to the mechanical input signal. The control has mechanical feedback that regulates the servo valve in relation to swashplate position to maintain displacement at the commanded level regardless of changes in system pressure.

The full featured 4T axial piston pumps manual control consists of two manual displacement controls with backup alarm switches. One of the controls incorporate a neutral override (NOR) solenoid and brake release port. The other control housing drains through the first control housing to provide neutral override function.

Manual controls for use on one pump are also available and can be used in combination with another type of control on the other pump. The servo control valve has variable geometry porting to regulate swashplate response relative to input command. The control performs small displacement change commands with maximum controllability throughout the entire stroking range of the pump. It completes large displacement change commands with rapid swashplate response. Optional servo supply and drain orifices are available for special response needs.

The control also has a full over-travel spool that allows input at a faster rate than swashplate movement without damage to the control. Any swashplate position error is feed back to the servo valve for instant correction.

### Features and Benefit of MDC

- The MDC is a high gain control: Small movements of the control handle move the servo valve to full open position porting maximum flow to the servo cylinder.
- The full over-travel spool design allows rapid changes in input signal without damaging the control mechanism.
- The MDC provides a fast response with low input force.
- Precision parts provide repeatable and accurate displacement settings.
- Mechanical feedback maintains pump displacement regardless of changes in system pressure.
- The operator is isolated from swashplate vibration.
- The swashplate and servo cylinder, as well as the control valve, are spring centered so the pump returns quickly to neutral in the absence of control input.

The pump returns to neutral:

- if the prime mover is shut down;
- if the external control linkage fails at the control handle;
- if there is a loss of charge pressure.

## Features and Options

### Control Input Signal

The figure and table below relate the input electrical signal to pump displacement, (swashplate position), for each coil configuration.

*Pump displacement versus Electrical signal*

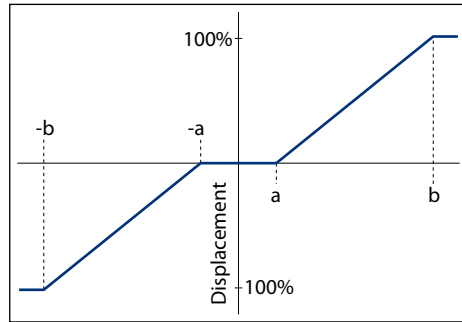

P001015E

### Response Time

You can tailor the time to change from zero to maximum displacement using orifices incorporated in the gasket between the control and pump housing. Using orifices you can match swashplate response to the acceleration and deceleration requirements of your application. Verify proper orifice selection by testing.

*MDC Response Time (Maximum to Maximum)*

Frame size (cm <sup>3</sup> )	Fast (no orifice)	Medium	Slow (standard)
41/51	0.6 sec	1.6 sec	2.5 sec

Neutral to maximum swashplate response is approximately 60% of the time for maximum to maximum swashplate travel. For other response times please contact your Danfoss representative.

*MDC Schematic*

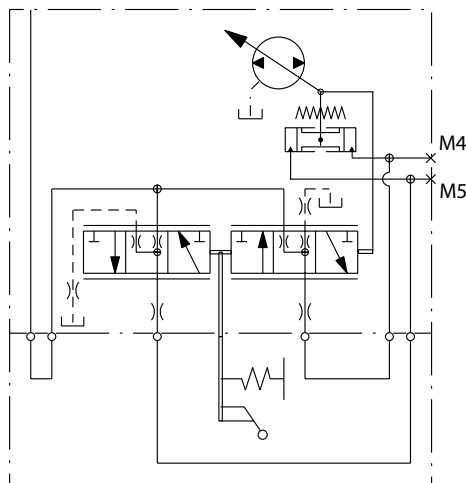

P100404E

## Features and Options

*Cross-section of MDC*

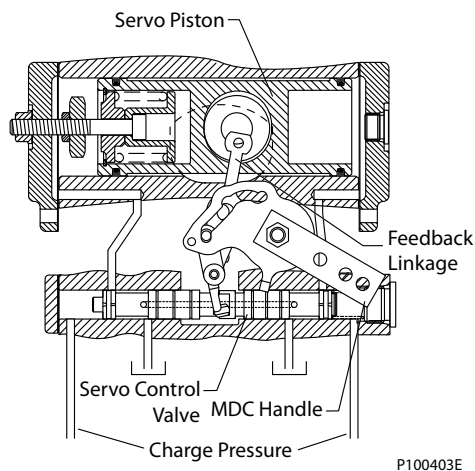

### Control Handles

Either straight or clevis (offset) style control handles are available for the MDC. The straight style handle minimizes the overall height of the pump and control. The clevis style handle provides additional clearance between the handle and control housing and works well for clevis style linkage installations.

Maximum allowable input torque at the control handle is 17 N·m (150 lbf·in). The maximum allowable bending moment is 4 N·m (35 in·lbf).

*Pump Flow Direction with MDC*

Input Shaft Rotation	CW		CCW	
	Handle of rotation	CCW	CW	CCW
Port A flow	Out	In	In	Out
Port B flow	In	Out	Out	In
High pressure servo guage port	M4	M5	M4	M5

*MDC Handle Options*

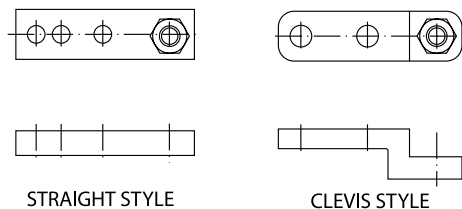

### Electric Solenoid Override to Neutral

This normally open solenoid valve (C) shunts both ends of the servo piston. This prevents the pump from stroking. When energized, the valve closes, allowing the pump to operate normally. This option is ideally suited for operator presence or auto-resume functions without prime mover shut down. This solenoid is available in 12 or 24 Vdc with 2 Amp. maximum current draw. It is available with DEUTSCH 2-way or with a Packard Weather-Pack 2-way shroud connector.

Features and Options

**Emergency Override to Neutral with Port for Brake Pressure Release**

This solenoid valve (C) operates as the override to neutral above, and drains a spring-applied, hydraulically-released brake (port X7). Energizing the valve allows the pump to operate as normal, while also charging port X7 to release the brake. This option is ideally suited for emergency stop functions without prime mover shut down. The solenoid is available in 12 or 24 Vdc with 2 Amp. maximum current draw. It is available with DEUTSCH 2-way or with a Packard Weather-Pack 2-way shroud connector.

*Electric Override to Neutral Specifications*

Solenoid State at Override Activation	De-energized
Voltage	12 or 24 Vdc
Maximum Current	2 A

*Hydraulic Schematic for MDC with Override Options*

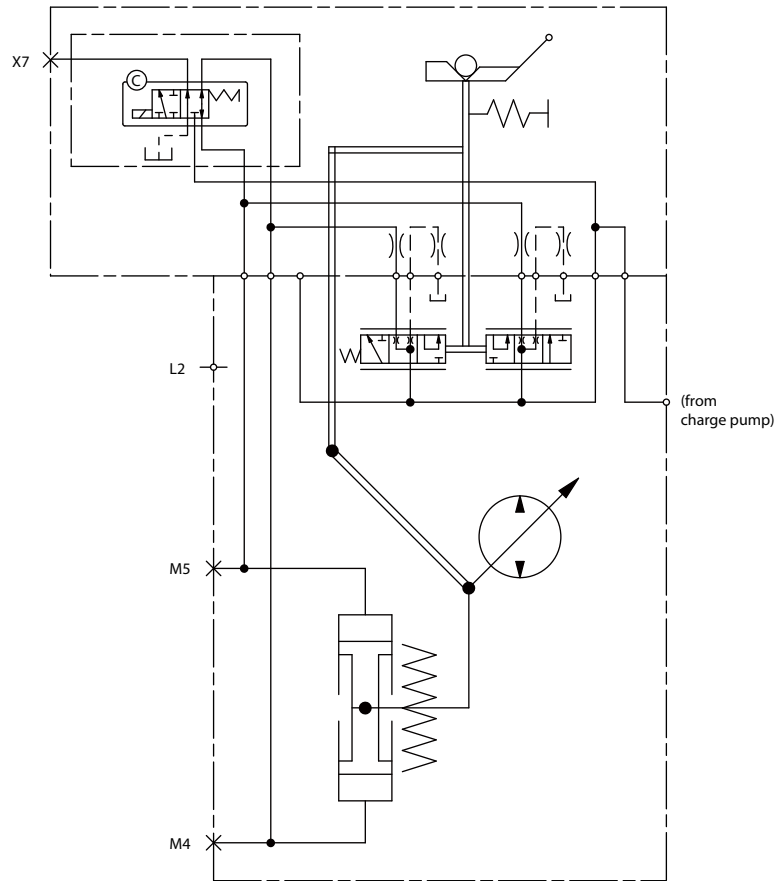

## Features and Options

### Neutral Start Switch (NSS)

This option provides an electrical switch contact that is closed when the control handle is in its neutral (0°) position. The switch contact opens when the control handle rotates approximately 1.5° to 2° clockwise (CW) or counterclockwise (CCW) from neutral.

The switch is rated for 5 Amp. inductive load at 12 or 24 Vdc. It is available with screw terminals (no connector) or with a Packard Weather-Pack 2-way tower connector or DEUTSCH 2-way connector..

Wire the NSS in series with the engine starting circuit to ensure the pump is in neutral position before allowing the engine to start.

#### *Neutral Start Switch Specifications*

<b>Switch Neutral Position</b>	Closed
<b>Voltage</b>	12 or 24 Vdc
<b>Current Rating</b>	5 A
<b>Neutral Play</b>	± 2°

### NSS with Back-up Alarm (BUA) Switch

The BUA switch contact is open until the control handle rotates 2.6° to 3.75° from neutral. The BUA switch closes when the control handle rotates either clockwise (CW) or counterclockwise (CCW) from neutral (choose one direction only). The NSS function operates as described above.

The BUA contacts are rated for 2.5 Amp. resistive load at 12 or 24 Vdc. The NSS contacts are rated for 5 Amp. inductive load at 12 or 24 Vdc. This switch is available with screw terminals (no connector) or with a Packard Weather-Pack 4-way tower connector or Deutsch 2-way, 4-way connector..

Wire the NSS as described above. Wire the BUA switch in series with a back-up alarm to have the alarm sound when the operator moves the pump control handle into reverse.

#### *Backup alarm switch option*

<b>Switch Neutral Position</b>	Open
<b>Voltage</b>	12 or 24 Vdc
<b>Current Rating</b>	2.5 A
<b>Alarm Direction</b>	CW or CCW
<b>Neutral Play</b>	± 2.6° to 3.75°

### Connectors

For available connectors and dimensions, see outline drawings: [Manual Displacement Control Options](#).

Features and Options

Hydraulic schematic for MDC with override options and NSS

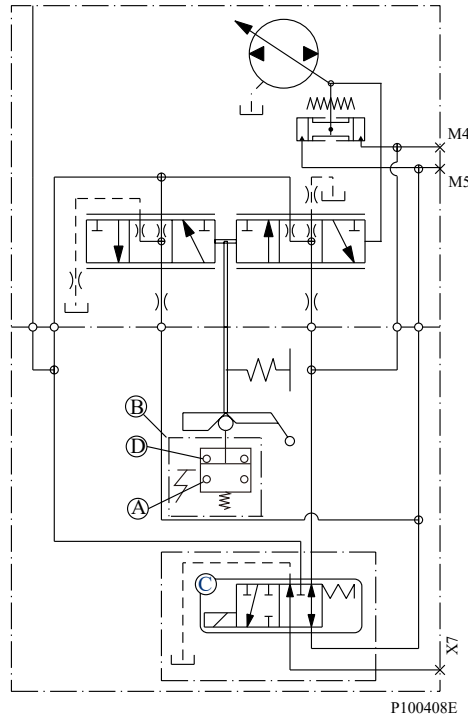

- (A) = Backup alarm switch contacts (green wire) (closed in reverse)
- (B) = Neutral start switch w/ backup alarm
- (C) = Electric solenoid override to neutral w/ brake release
- (D) = Neutral start switch contacts (black wire) (closed in neutral)

## Features and Options

### Non-feedback, proportional hydraulic control (NFPH)

The non-feedback proportional hydraulic (NFPH) control is a hydraulic proportional control in which an input pressure signal directly controls the pump servo piston to achieve pump displacement.

4T pumps with NFPH control have a special servo cylinder capable of providing proportional control with a hydraulic input.

Swashplate position is proportional to the differential signal pressure at ports X1 and X2, but displacement is also dependent on pump speed and system pressure. This characteristic of non-feedback controls provides a natural power limiting function by reducing the pump swashplate angle as system pressure increases. The accompanying graph shows typical operating characteristics.

The system may require tuning through the pump orifice combinations, control pressure supply line sizing, actuation device output pressure and flow adjustments to achieve proper vehicle performance characteristics

*Pump displacement versus signal pressure*

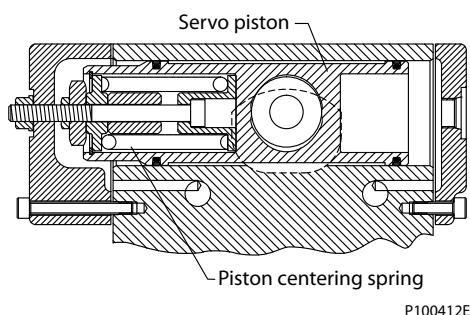

*Non-feedback proportional hydraulic control schematic*

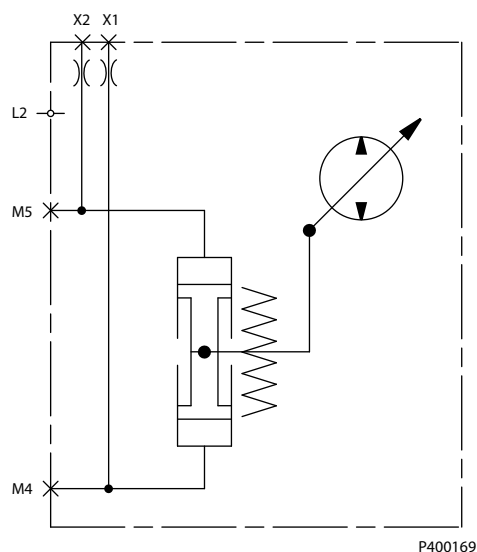

*Pump flow direction with NFPH control*

Input Shaft Rotation	CW		CCW	
	X1	X2	X1	X2
High pressure at port:				
Port A flow	Out	In	In	Out
Port B flow	In	Out	Out	In
High servo gauge port	M4	M5	M4	M5

## Features and Options

NFPH pump displacement to Input signal

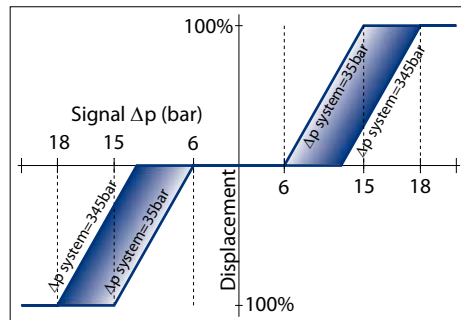

P001628E

The Input Signal ( $\Delta p$ ) values in the graph above are approximations at 1800 RPM and system delta pressures as indicated in the graph above. The values are dependent on input speed and delta pressure operating conditions.

### Features and Benefits of the NFPH control

- Eliminates mechanical linkage for flexibility of control design
- Power limiting characteristic reduces machine power requirements
- Compatible with dual axis joysticks for dual path applications
- Smooth operation

### Connectors and Port locations

Refer to [outline drawings](#).



## Installation Drawings

### Manual Displacement Control (MDC)

#### Port Description

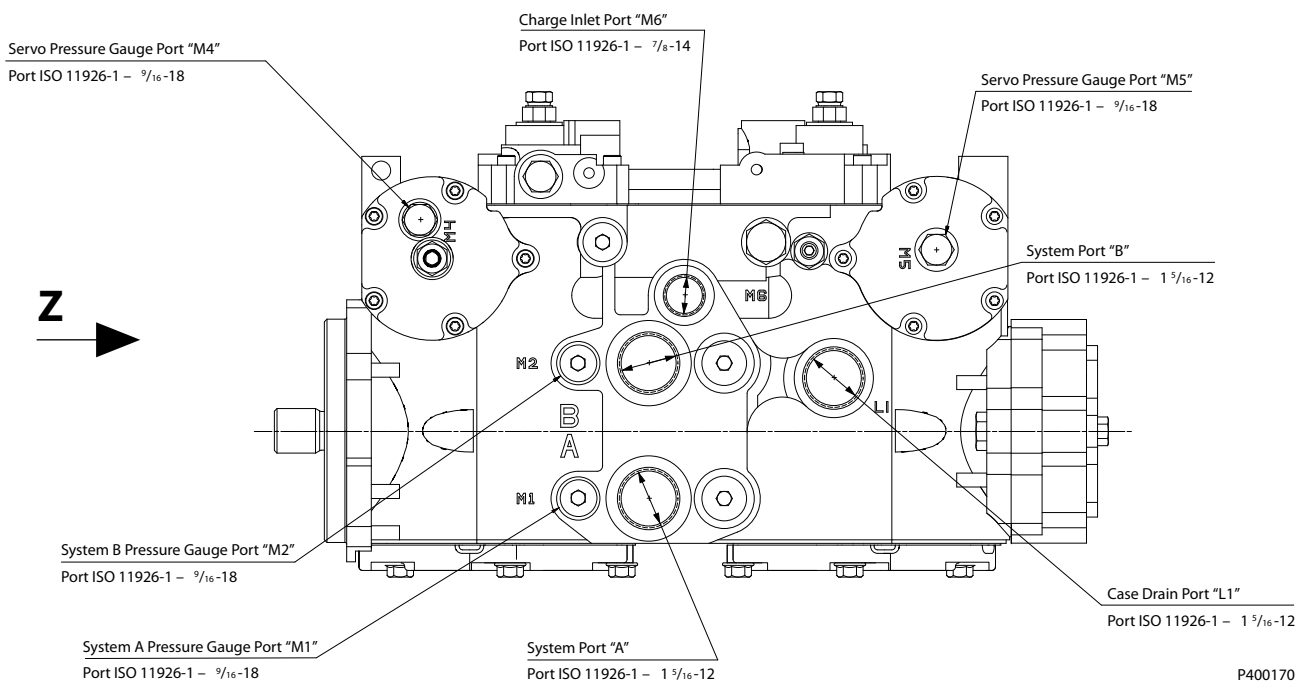

P400170

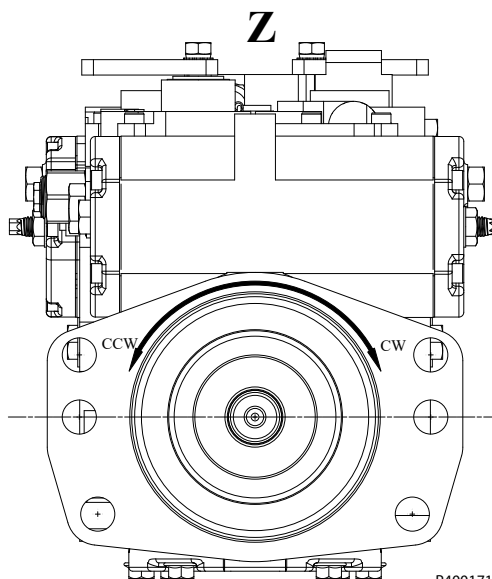

P400171

Port	Description	Sizes	Port	Description	Sizes
A	System port "A"	1 5/16 - 12	M2	System "A" pressure gauge port "M1"	9/16 - 18
B	System Port "B"	1 5/16 - 12	M1	System "C" pressure gauge port "M1"	9/16 - 18
C	System Port "C"	1 5/16 - 12	M2	System "D" pressure gauge port "M2"	9/16 - 18
D	System Port "D"	1 5/16 - 12	M4 x2	Servo pressure gauge port "M4"	9/16 - 18
L1	Case Drain Port "L1"	1 5/16 - 12	M5 x2	Servo pressure gauge port "M5"	9/16 - 18

Installation Drawings

Port	Description	Sizes	Port	Description	Sizes
<b>L2</b>	Case Drain Port "L2"	1 5/16 - 12	<b>M6 x2</b>	Charge inlet port "M6"	7/8 - 14
<b>M1</b>	System "A" pressure gauge port "M1"	9/16 - 18			

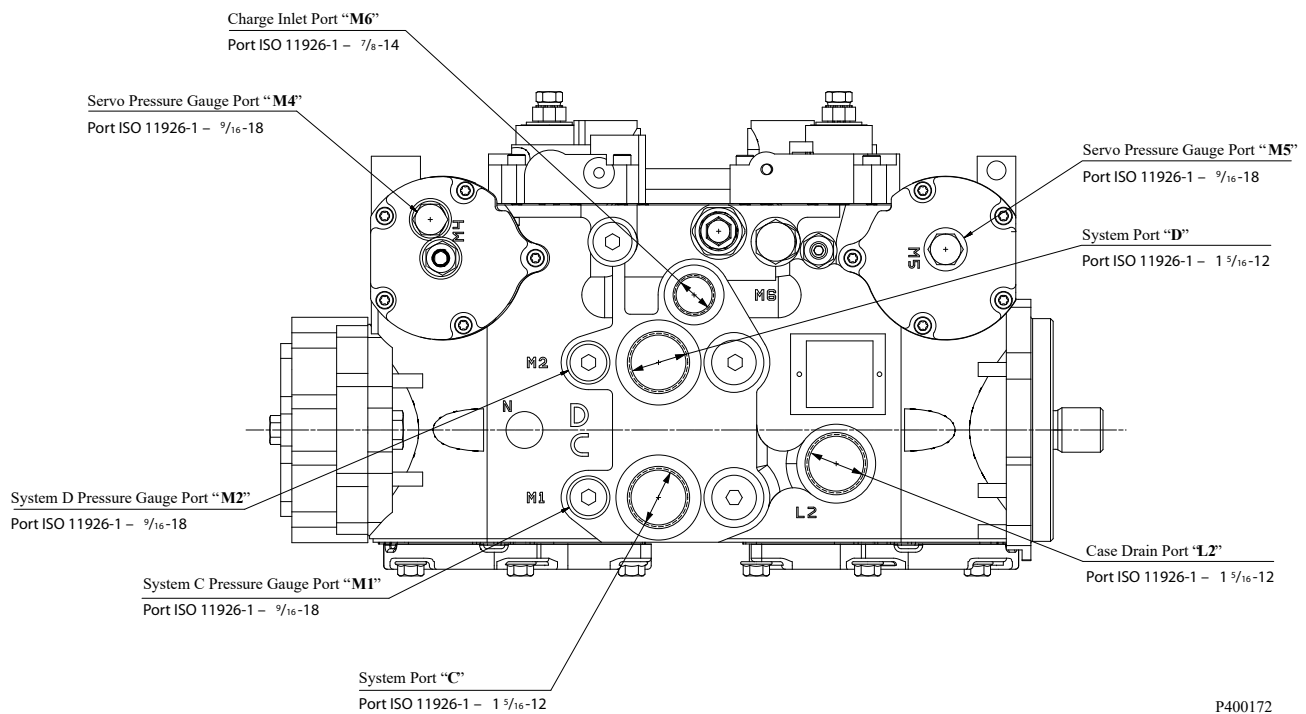
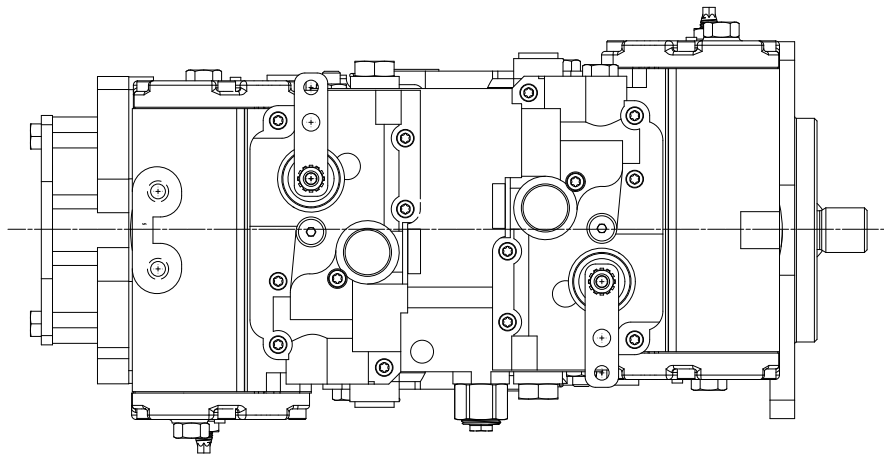

**Installation Drawings**

**Dimensions**

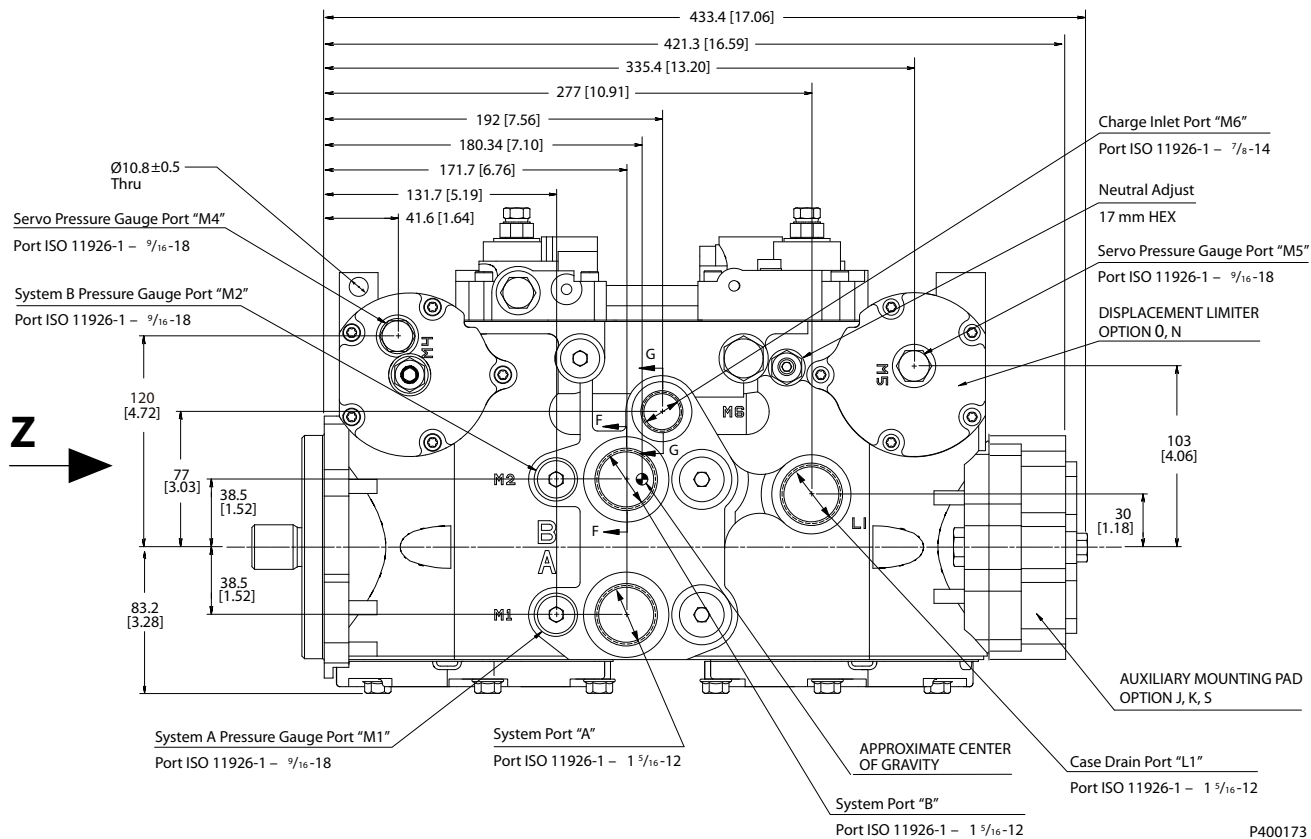

P400173

Installation Drawings

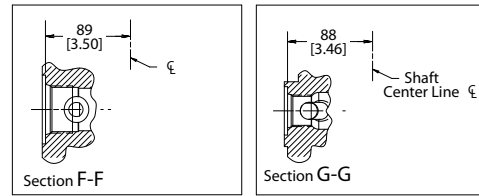
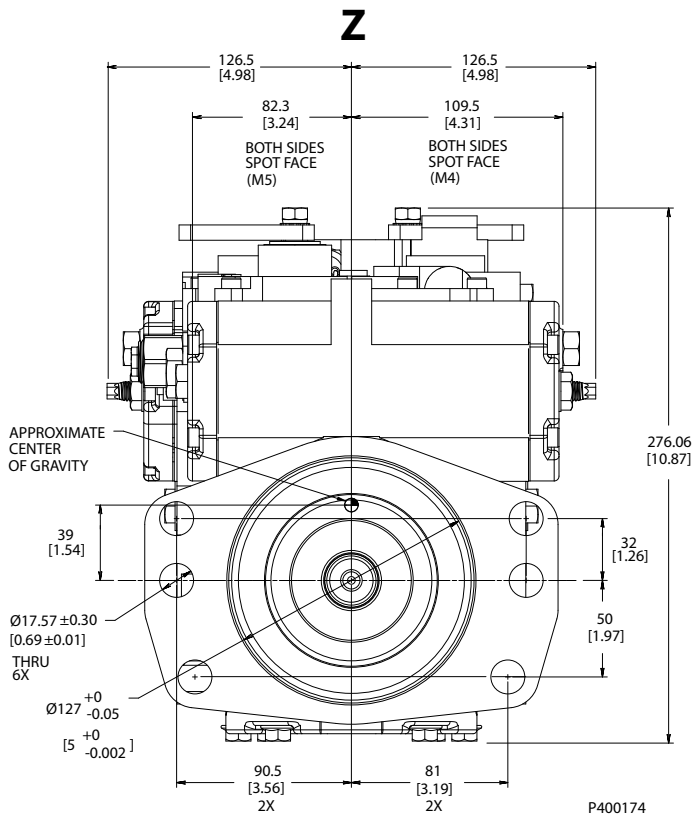

Adjustable displacement limiters

Shaft rotation	CW		CCW	
	1	2	1	2
Displacement limiter side	1	2	1	2
Limited flow through port	B, C	A, D	A, D	B, C

Determine rotation by viewing pump from the input shaft end. Contact your Danfoss representative for specific installation drawings.

Installation Drawings

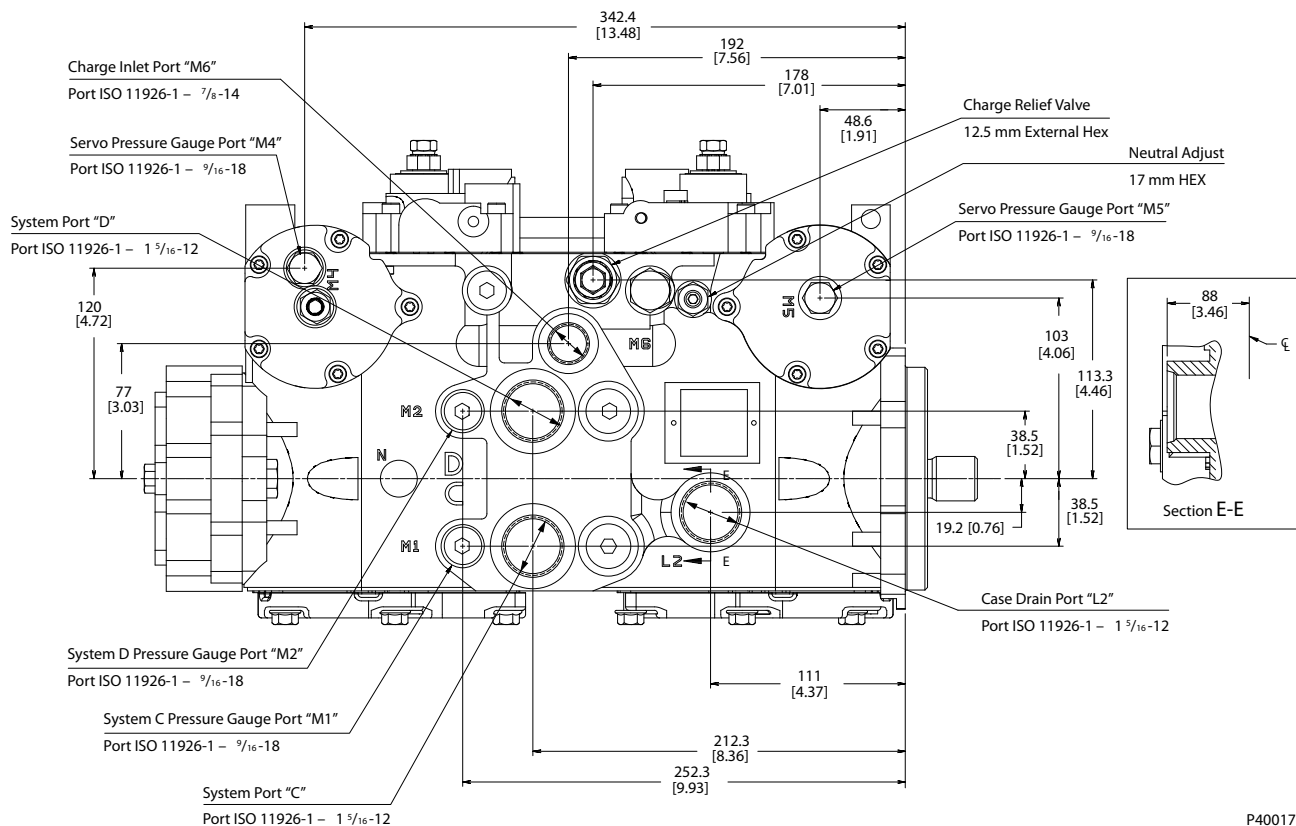
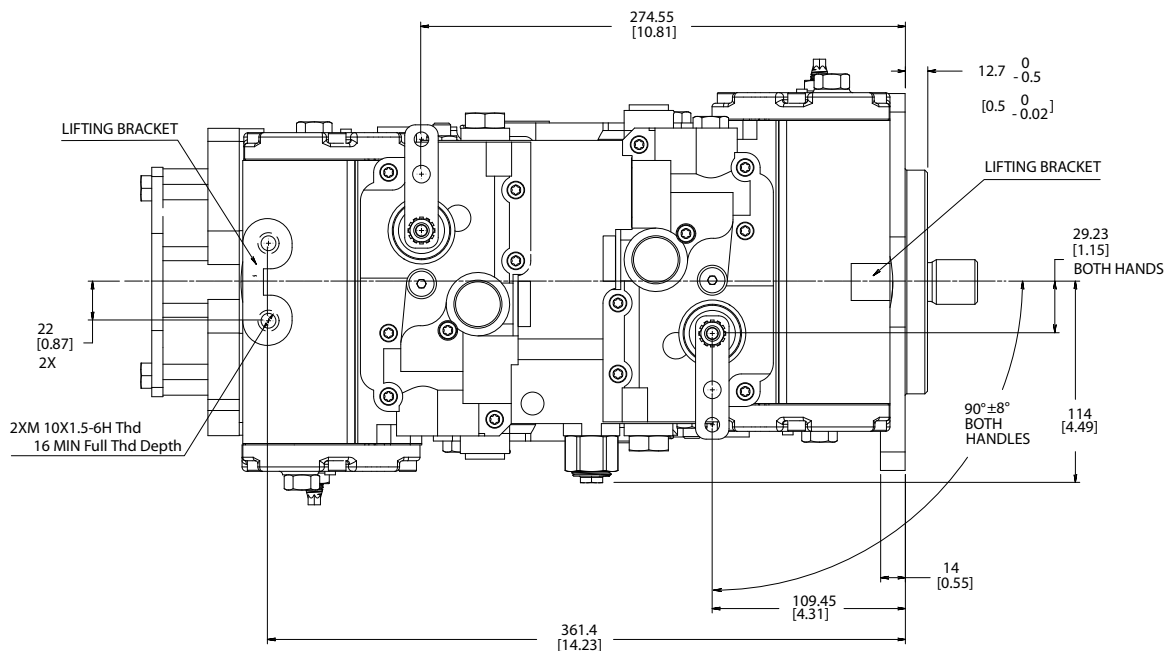

P400175

**Installation Drawings**

**Non-Feedback, Proportional Hydraulic (NFPH)**

**Port Description**

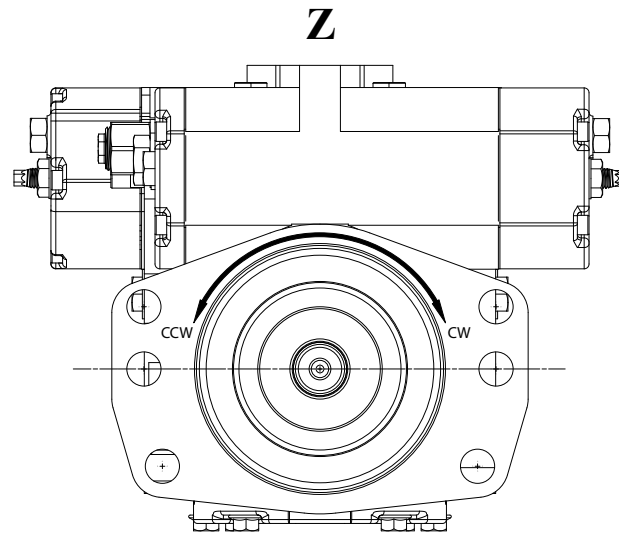
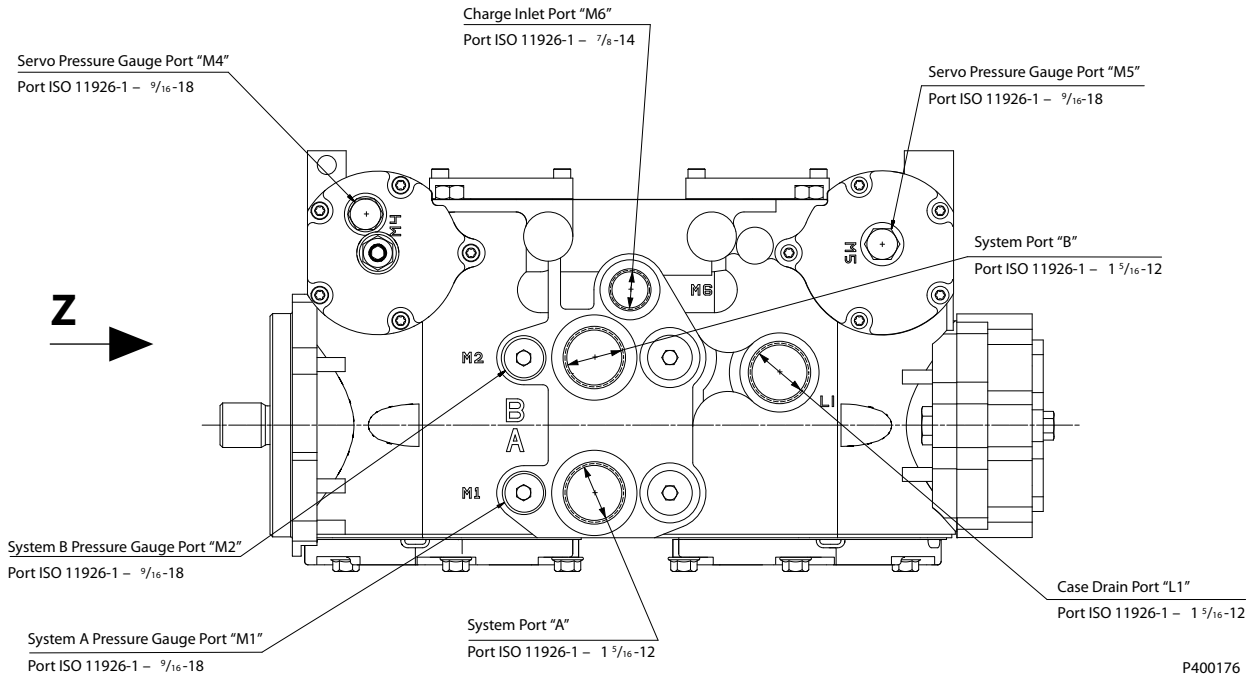

Port	Description	Sizes	Port	Description	Sizes
<b>A</b>	System port "A"	1 5/16 - 12	<b>M1</b>	System "C" pressure gauge port "M1"	9/16 - 18
<b>B</b>	System Port "B"	1 5/16 - 12	<b>M2</b>	System "D" pressure gauge port "M2"	9/16 - 18
<b>C</b>	System Port "C"	1 5/16 - 12	<b>M4 x2</b>	Servo pressure gauge port "M4"	9/16 - 18
<b>D</b>	System Port "D"	1 5/16 - 12	<b>M5 x2</b>	Servo pressure gauge port "M5"	9/16 - 18
<b>L1</b>	Case Drain Port "L1"	1 5/16 - 12	<b>M6 x2</b>	Charge Inlet port "M6"	7/8 - 14
<b>L2</b>	Case Drain Port "L2"	1 5/16 - 12	<b>X1</b>	Control Port "X1"	9/16

**Installation Drawings**

Port	Description	Sizes	Port	Description	Sizes
<b>M1</b>	System "A" pressure gauge port " <b>M1</b> "	9/16 - 18	<b>X2</b>	Control Port " <b>X2</b> "	9/16
<b>M2</b>	System "B" pressure gauge port " <b>M2</b> "	9/16 - 18			

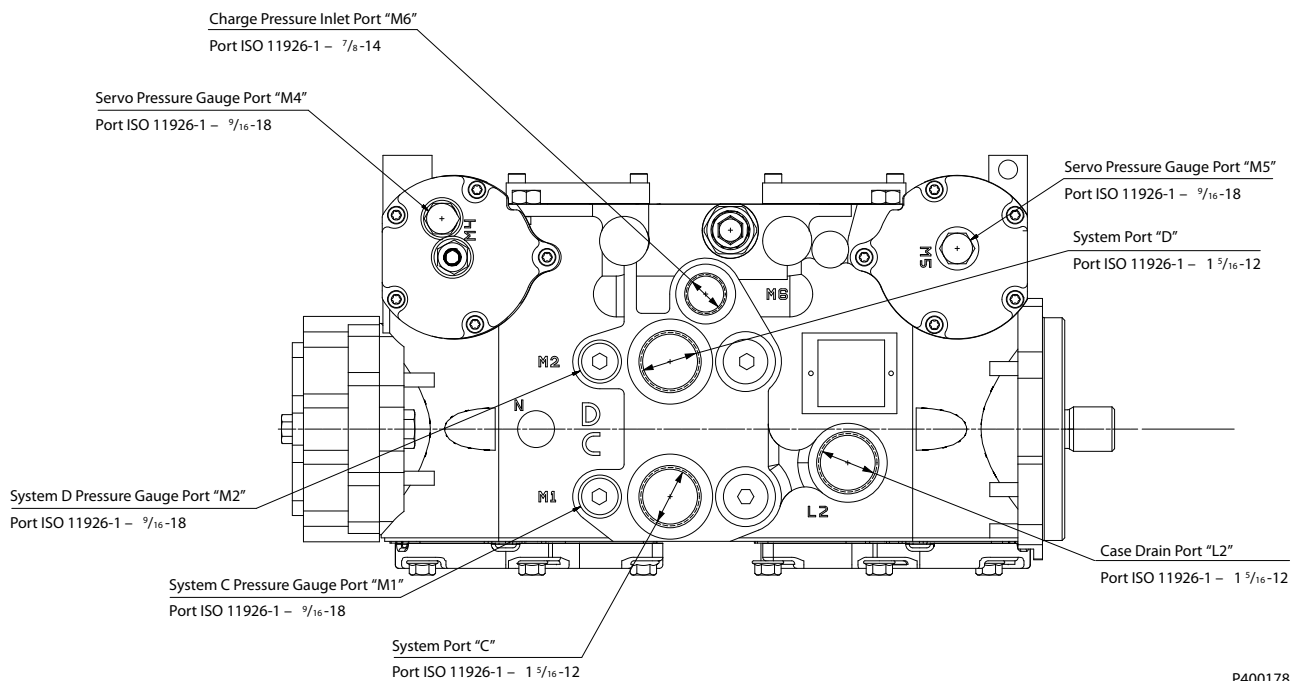
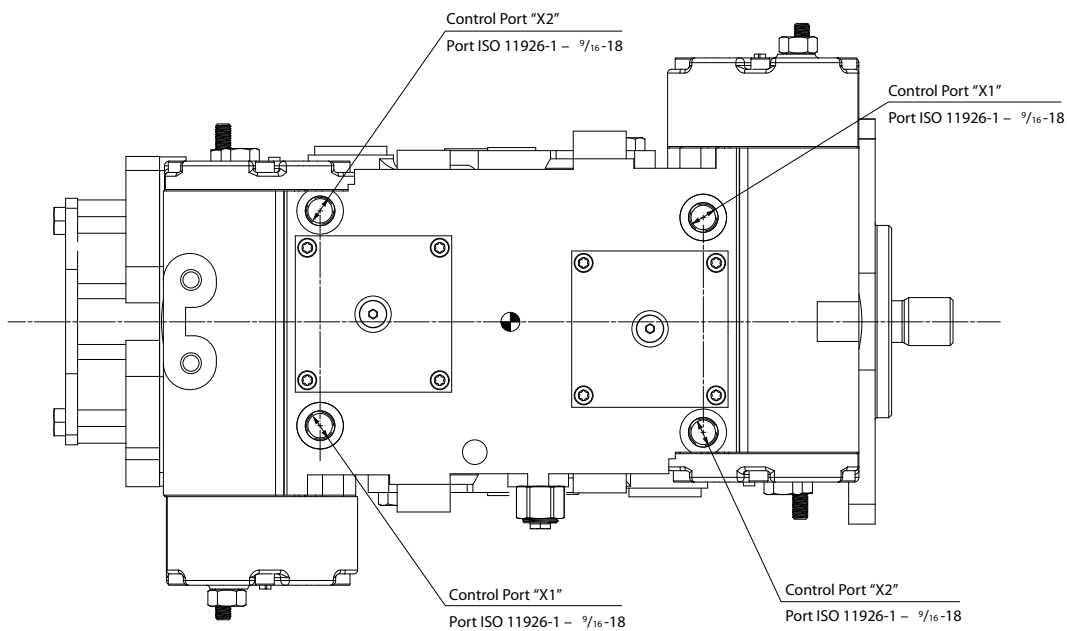

P400178

Installation Drawings

Dimensions

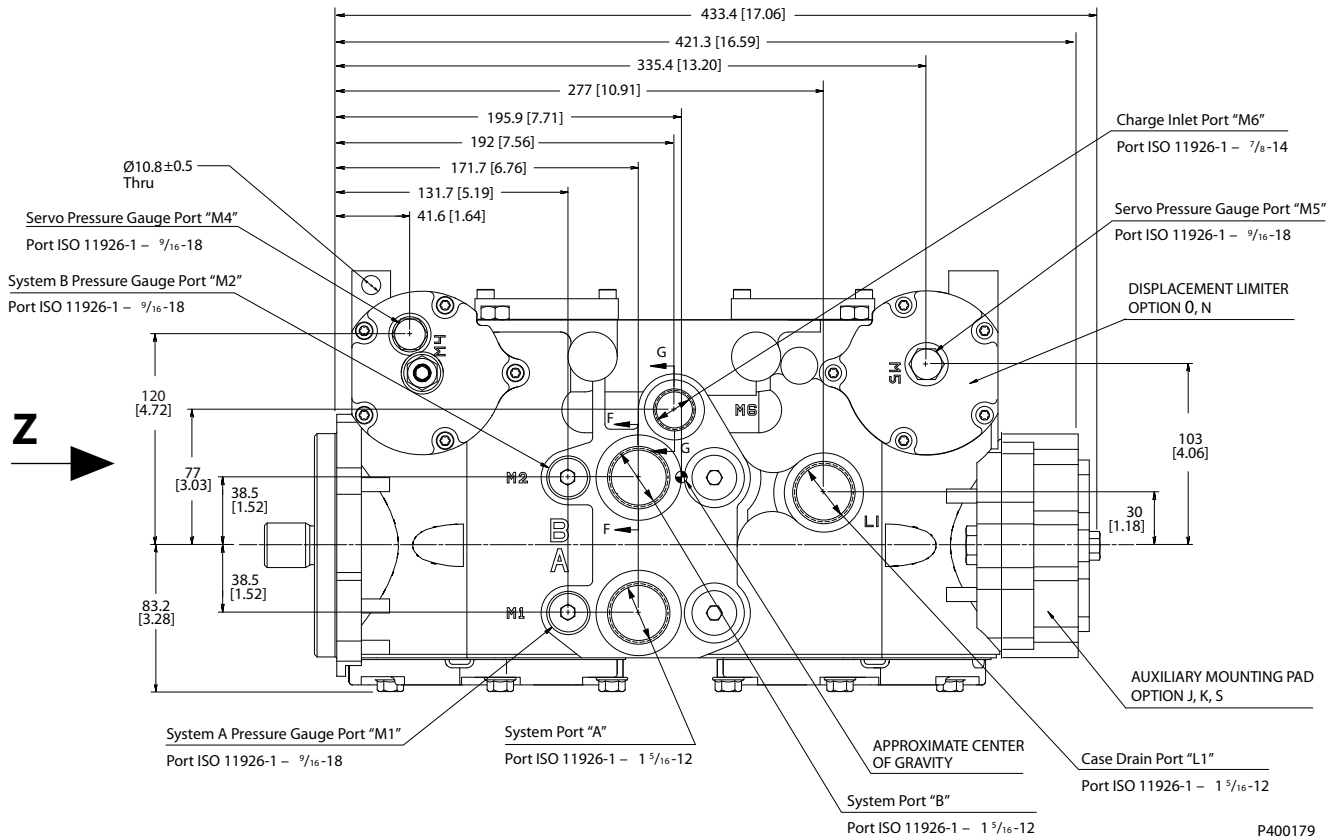



Installation Drawings

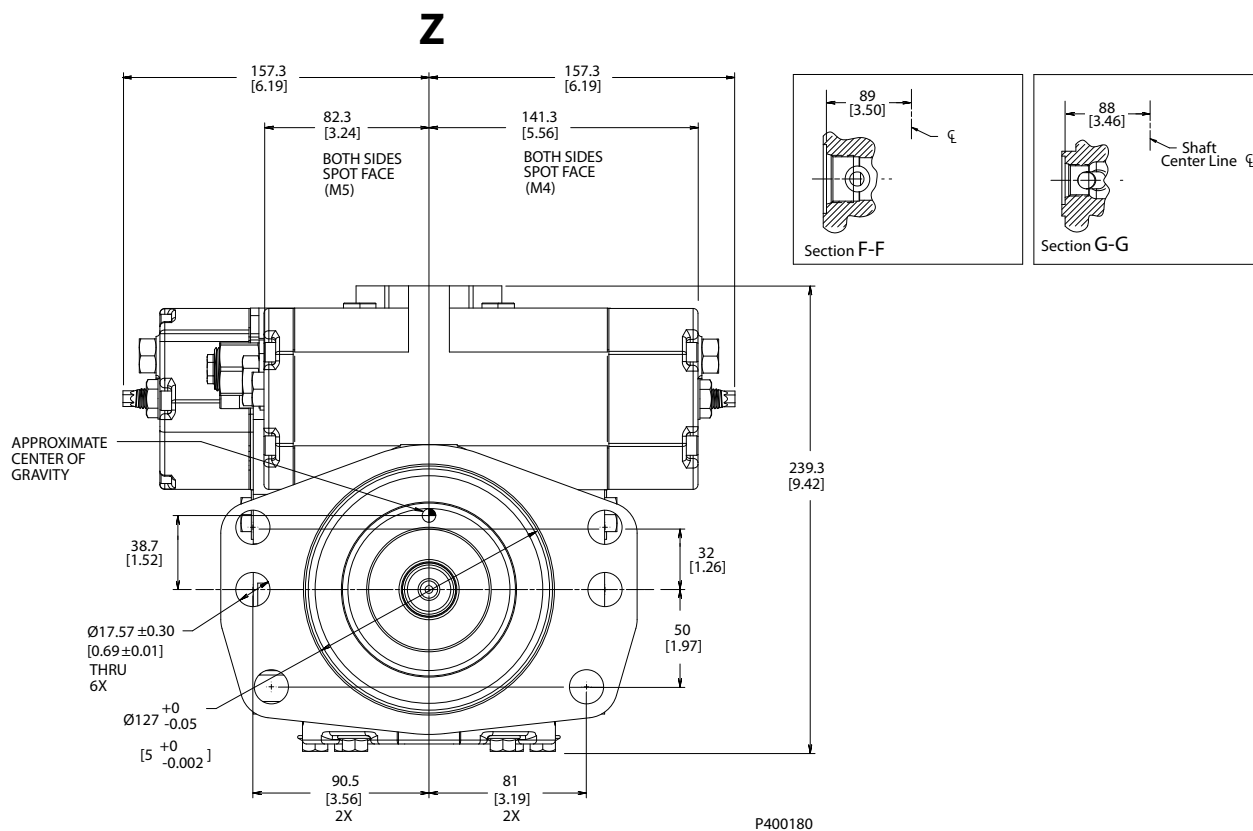

**Installation Drawings**

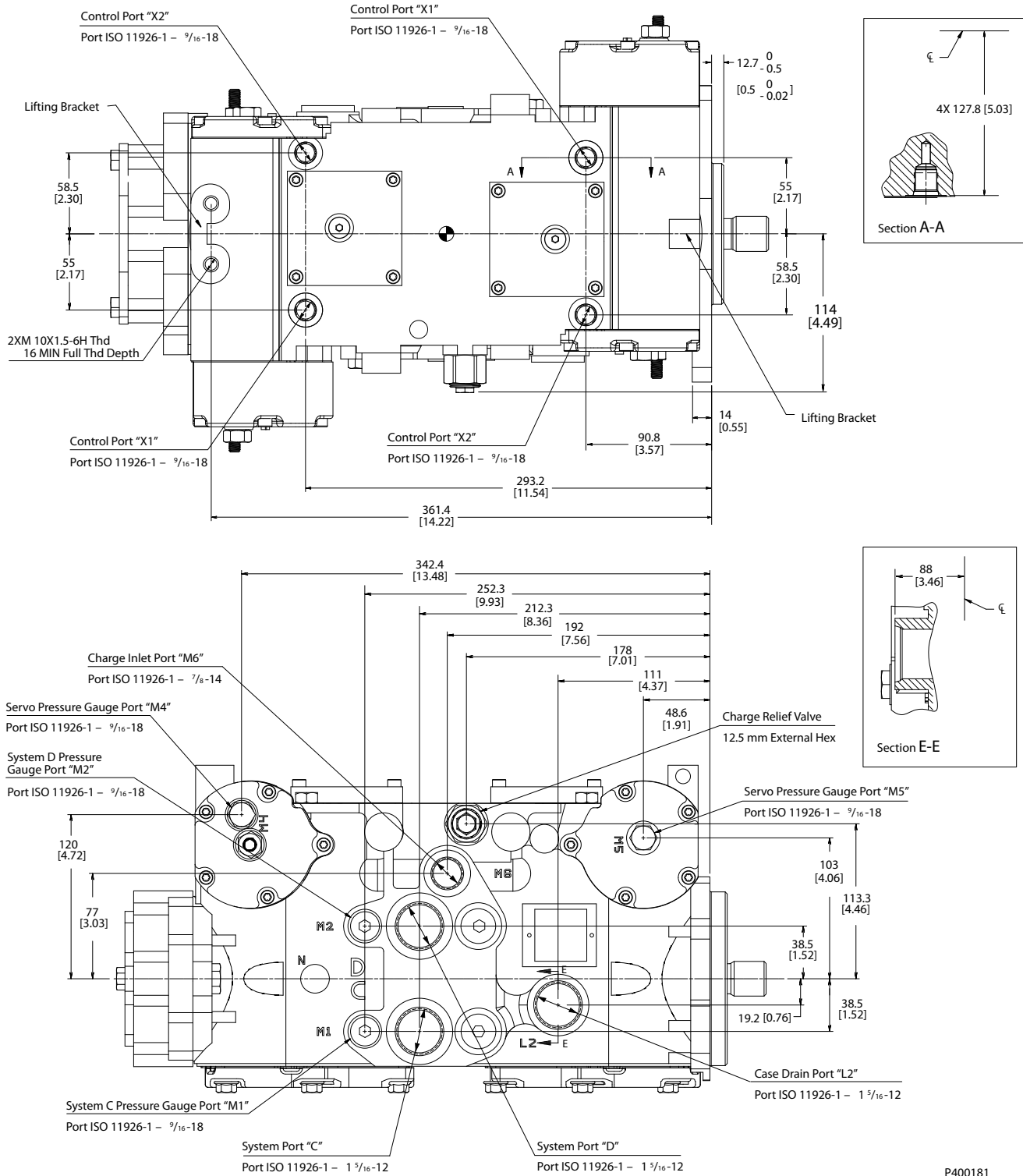

### Installation Drawings

#### Shaft Options

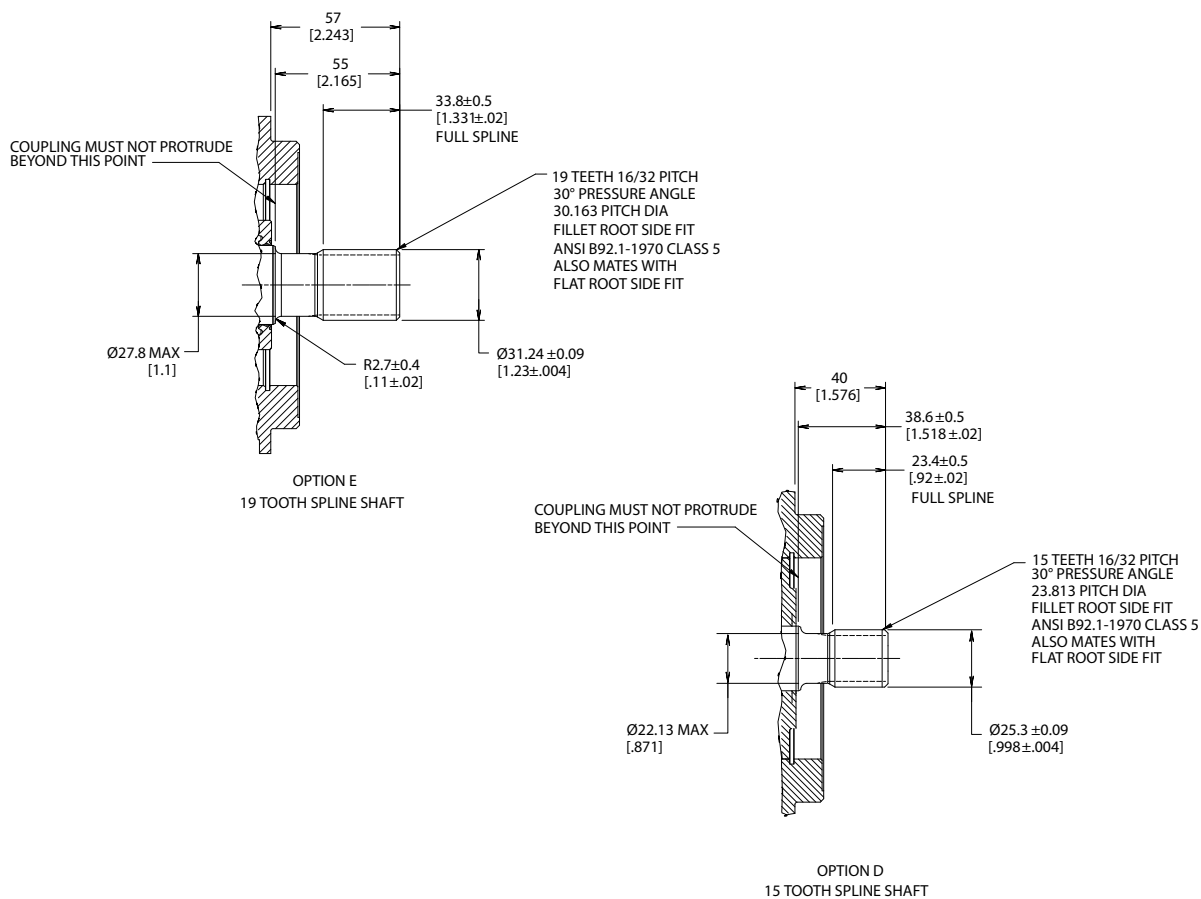

P400182

Installation Drawings

Displacement Limiter

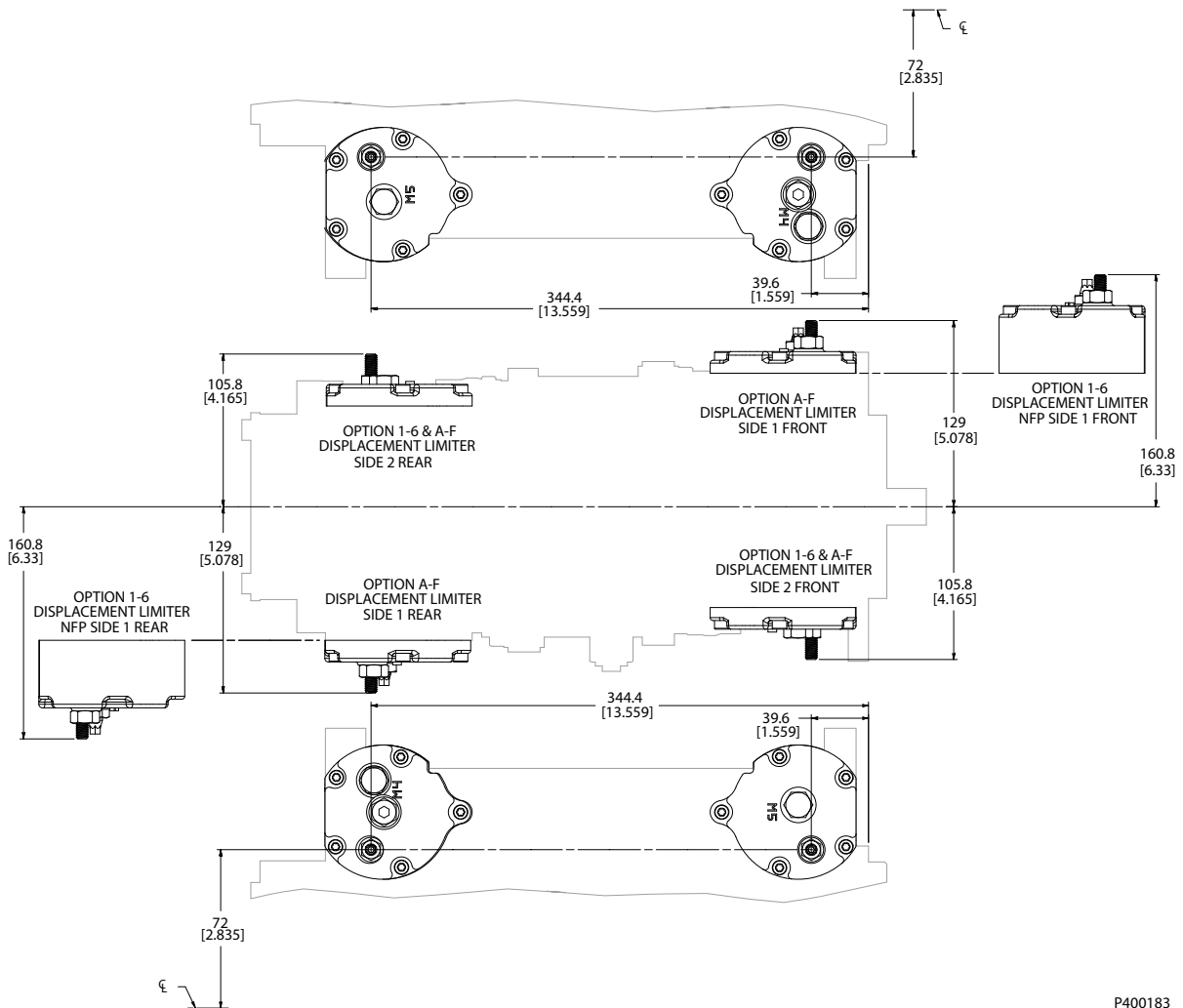

P400183

## Installation Drawings

### By-pass Valve

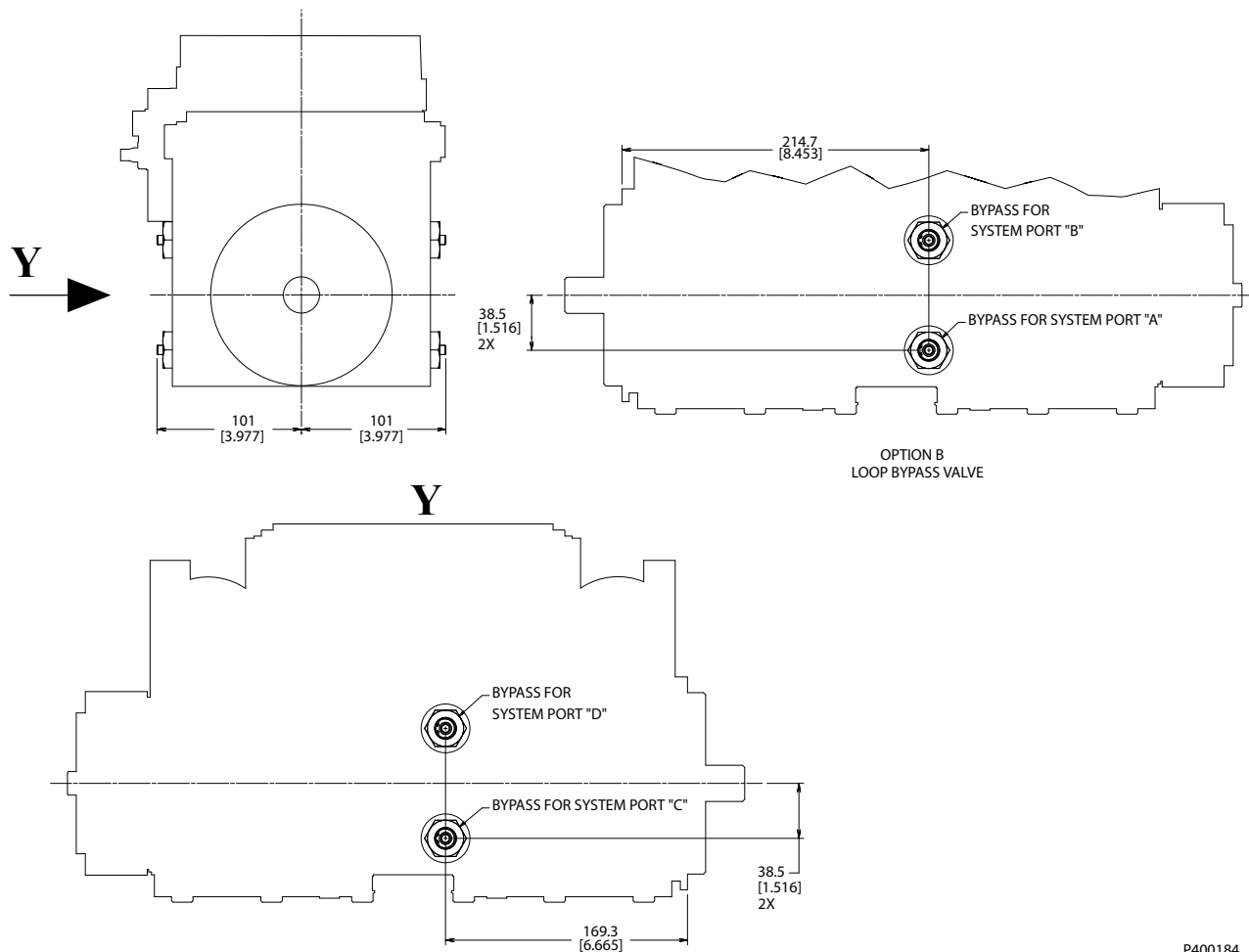

P400184

## Control Modules

### Manula Displacement Control (MDC) Options

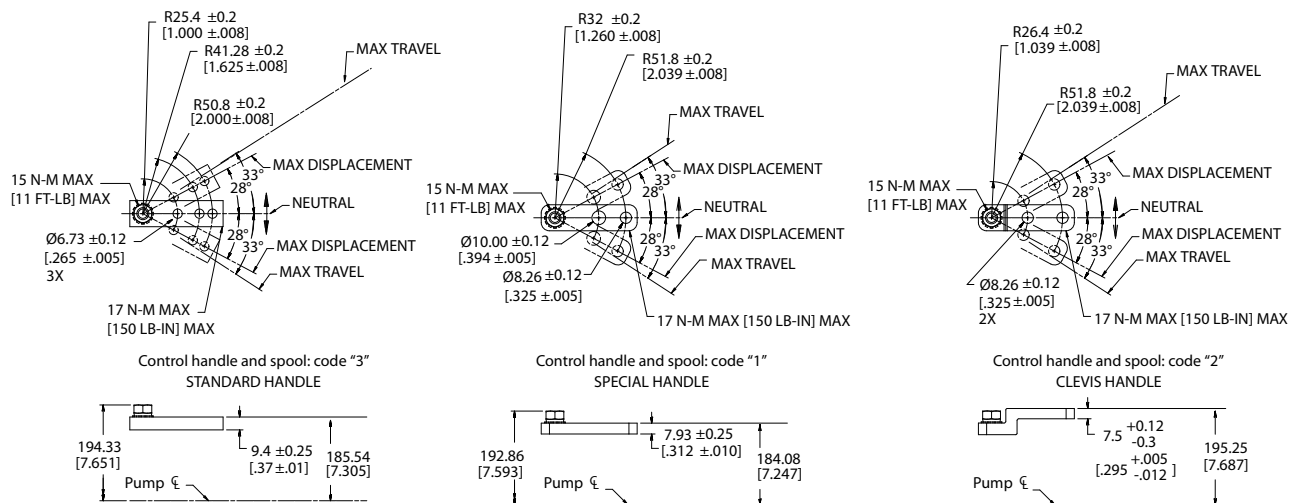

P400185

**Installation Drawings**

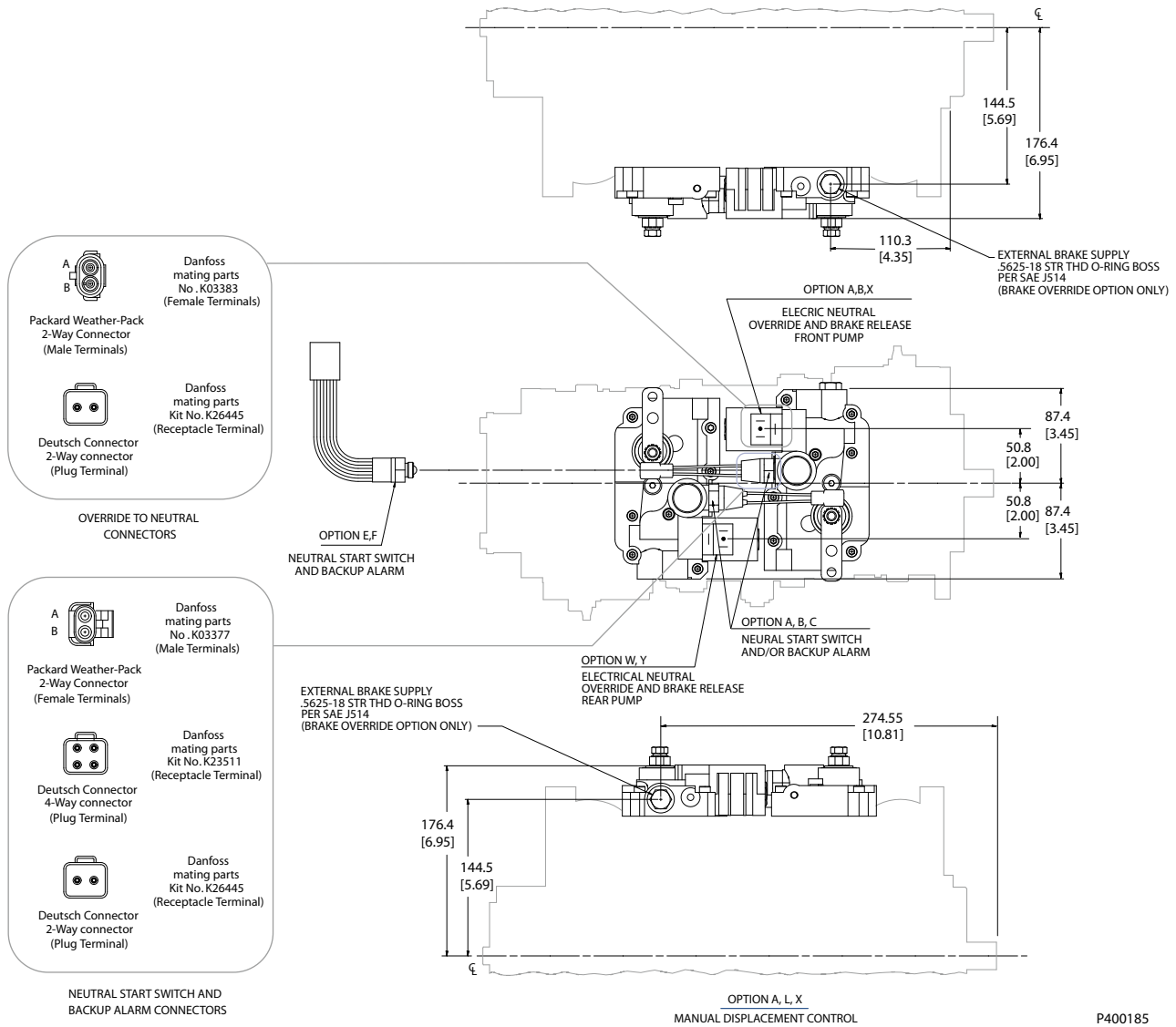

P400185

Installation Drawings

Auxiliary Mounting Pads

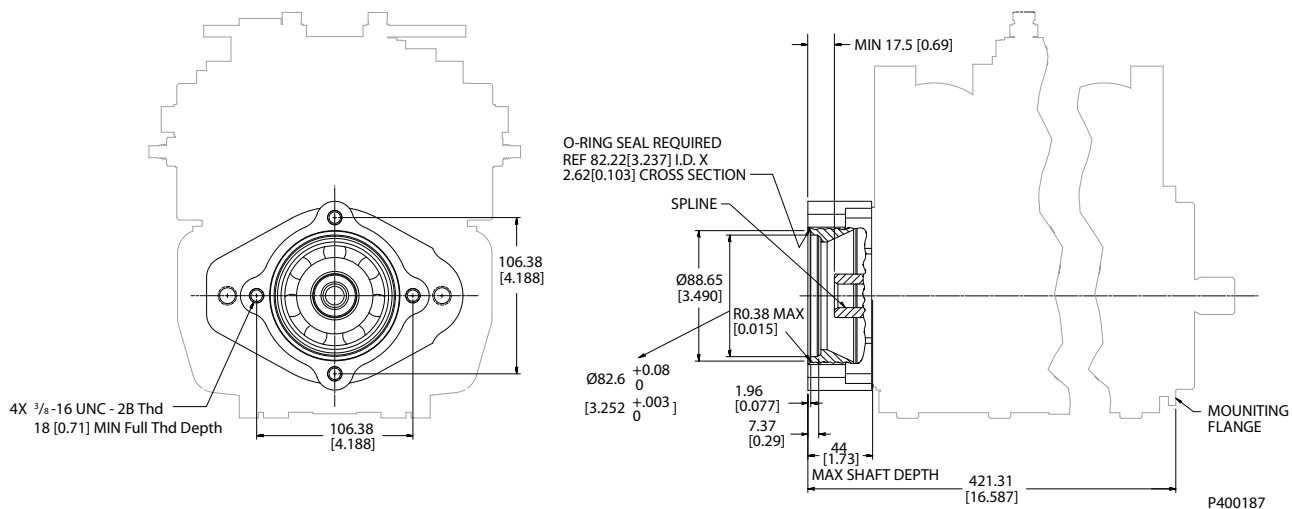

Auxiliary mounting flange and coupling options

Auxiliary mounting flange	Spline pitch diameter P	Number of teeth N
Option J	14.288 [0.563] 16/32	9 tooth
Option K	17.463 [0.688] 16/32	11 tooth
Option S	20.638 [0.813] 16/32	13 tooth

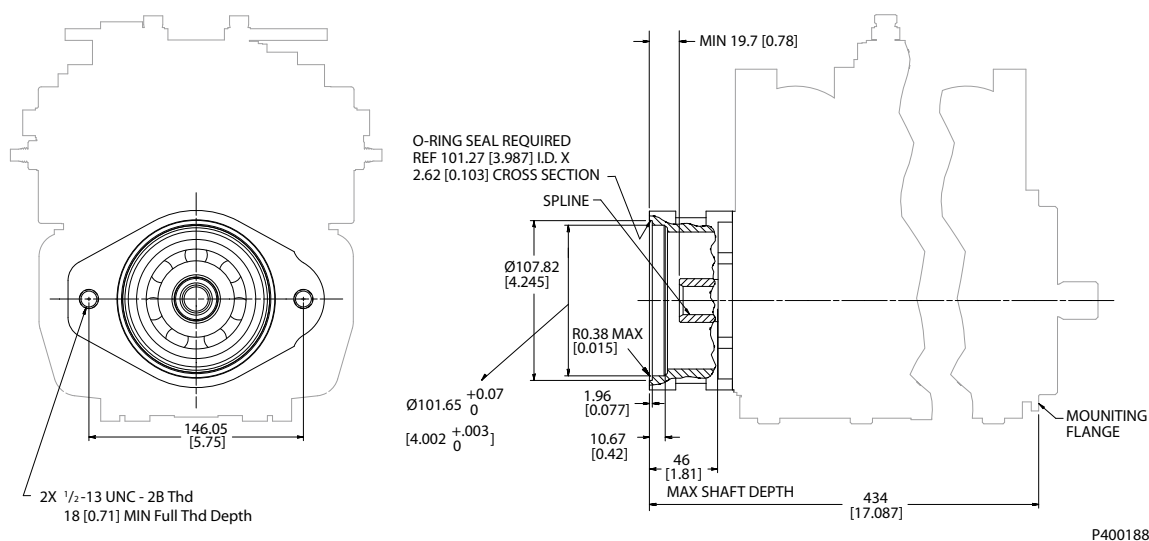

Auxiliary mounting flange and coupling options

Auxiliary mounting flange	Spline pitch diameter P	Number of teeth N
Option L	20.638 [0.813] 16/32	13 tooth

**Installation Drawings**

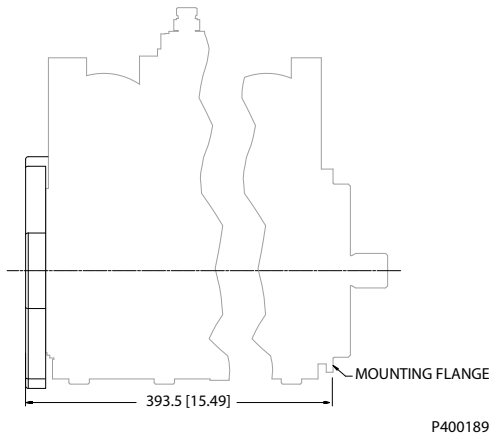

*Auxiliary mounting flange and coupling options*

Auxiliary mounting flange	Spline pitch diameter P	Number of teeth N
Option Q	-	-

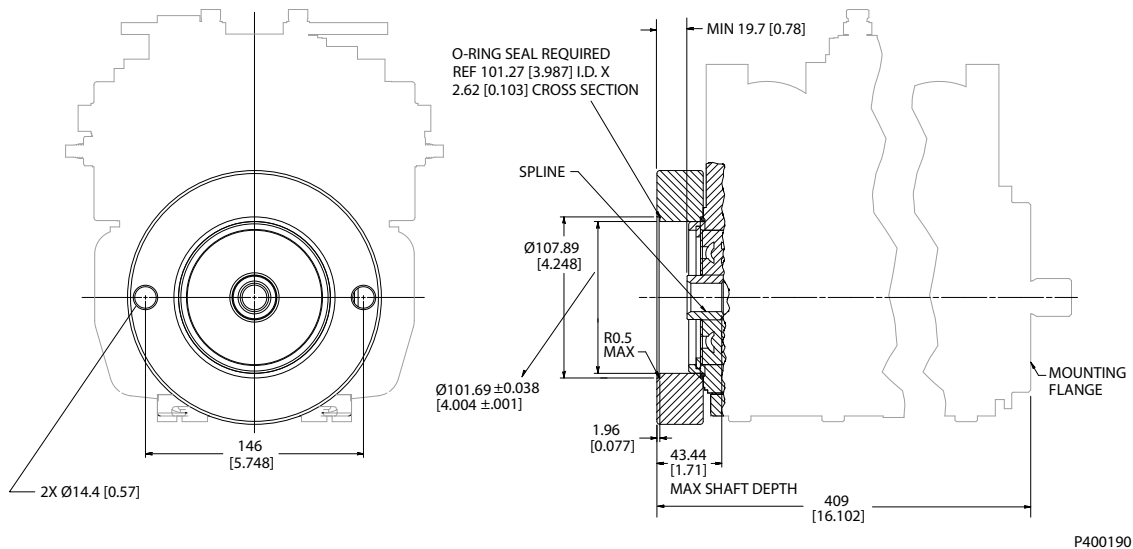

*Auxiliary mounting flange and coupling options*

Auxiliary mounting flange	Spline pitch diameter P	Number of teeth N
Option R	20.638 [0.813] 16/32	13 tooth



**Model Code**

**Model Code: A, Y, Z**

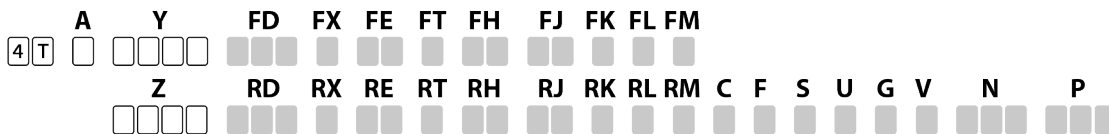

*Product Series*

Code	Description
-	4T axial piston pumps

*A - Rotation*

Code	Description
L	Pump, variable displacement, CCW rotation
R	Pump, variable displacement, CW rotation

*Y, Z - Displacement*

Code	cm <sup>3</sup> /rev [in <sup>3</sup> /rev]	Speed Sensing
41 BN	41cc/revolution (2.50 CU. IN.) x 2	none
51 DN	51cc/revolution (3.11 CU. IN.) x 2	none

**Model Code**

**Model Code: FD, FX, RD, RX**

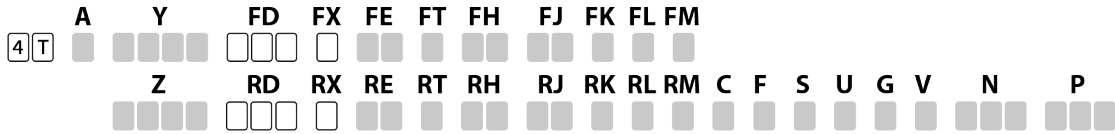

*FD, FX, RD, RX - Control Type*

Control Type	Control Description		Control Features
Manual Displacement	Neutral Start Switch	Override to Neutral	Control Handle and Spool
<b>X</b> = MDC, LIN, NAR DB, HF <b>A</b> = MDC, LIN, LF <b>L</b> = MDC, LIN, NAR DB, LF (Requires Engineering Approval)	BAS(only) with CW handle rotation: <b>A</b> = Weather BAS(only) with CCW handle rotation: <b>B</b> = Weather NSS(only) : <b>C</b> = DEUTSCH NSS+BAS with CW handle rotation: <b>E</b> = DEUTSCH NSS+BAS with CCW handle rotation: <b>F</b> = DEUTSCH <b>N</b> = none	Integral nor with brake release in front control: <b>B</b> = 12V, Deutsch <b>X</b> = 12V, Weather Stand Alone nor (front): <b>A</b> = 24V, DEUTSCH Integral nor with brake release in front control: <b>W</b> = 12V, Weather <b>Y</b> = 24V, Deutsch <b>N</b> = none	<b>1</b> = Special handle with high gain spool <b>2</b> = Clevis handle with high gain spool <b>3</b> = STD handle with high gain spool <b>N</b> = No handle

Control Type	Control Description		Control Features
Non-Feedback proportional	Style	Input	Other feature
<b>G</b> = NFP	<b>3</b> = Hydraulic	<b>N</b> = Not Available	<b>X</b> = Not Available

**Model Code**

**Model Code: FE, RE**

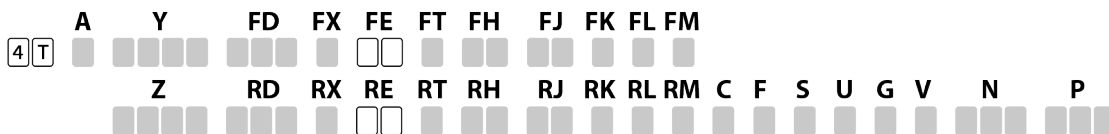

(● = Standard, ○ = Optional)

**FE, RE - Control Response Time**

Code	Description	41	51
<b>MDC</b>			
00=	Fast (No Orifice)	○	○
02=	Medium	○	○
03=	Slow	●	●

Code	Description	41	51
<b>NFPH CONTROLS</b>			
50=	No Orifice	●	●
52=	Medium, 1mm	○	○
53=	Slow, 0.8mm	○	○
55=	Fast, Special 1.3mm	○	○

**Model Code**

**Model Code: FT, RT, FH, RH, FJ, RJ, FK, RK**

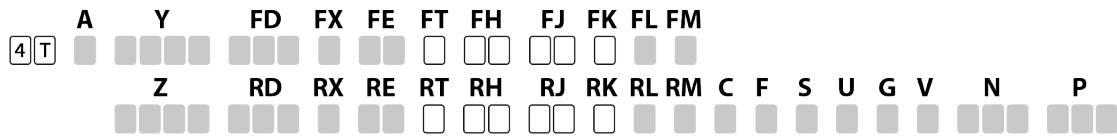

(● = Standard, ○ = Optional)

*FT, RT - Special Drive Features*

Code	Description	41	51
N	None	●	●
1	NFPH	●	●

*FH, RH - System Pressure Protection Port A and C*

Code	Description	41	51
NN	None (Check Valve Only)	●	●
21	210 bar (3045 psi)	○	○
25	250 bar (3625 psi)	○	○
28	280 bar (4060 psi)	○	○
30	300 bar (4350 psi)	○	○
32	325 bar (4715 psi)	○	○
34	345 bar (5000 psi)	○	○
36	360 bar (5220 psi)	○	-
38	385 bar (5585 psi)	○	-
41	415 bar (6020 psi)	○	-

*FJ, RJ - System Pressure Protection Port B and D*

Code	Description	41	51
NN	None (Check Valve Only)	●	●
21	210 bar (3045 psi)	○	○
25	250 bar (3625 psi)	○	○
28	280 bar (4060 psi)	○	○
30	300 bar (4350 psi)	○	○
32	325 bar (4715 psi)	○	○
34	345 bar (5000 psi)	○	○
36	360 bar (5220 psi)	○	-
38	385 bar (5585 psi)	○	-
41	415 bar (6020 psi)	○	-

*FK, RK - Loop Bypass Valve*

Code	Description	41	51
N	None	●	●
B	Bypass Valve	○	○

**Model Code**

**Model Code: FL, RL, FM, RM**

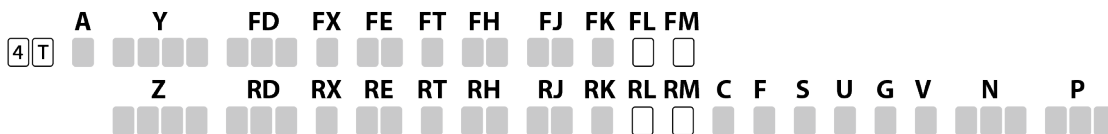

(● = Standard, ○ = Optional)

**FL, RL - Displacement Limiters Side 1**

Code	Description	41	51
<b>MDC</b>			
N	None	●	●
A	Adjustable limiters set to max. displacement	○	○
B	Adjustable limiters set to 96% of max. displacement	○	○
C	Adjustable limiters set to 92% of max. displacement	○	○
D	Adjustable limiters set to 88% of max. displacement	○	○
E	Adjustable limiters set to 84% of max. displacement	○	○
F	Adjustable limiters set to 80% of max. displacement	○	○

Code	Description	41	51
<b>NFPH Control</b>			
0	None	●	●
1	Adjustable limiters set to max. displacement	○	○
2	Adjustable limiters set to 96% of max. displacement	○	○
3	Adjustable limiters set to 92% of max. displacement	○	○
4	Adjustable limiters set to 88% of max. displacement	○	○
5	Adjustable limiters set to 84% of max. displacement	○	○
6	Adjustable limiters set to 80% of max. displacement	○	○

**FM, RM - Displacement limiters Side 2**

Code	Description	41	51
<b>MDC</b>			
N	None	●	●
A	Adjustable limiters set to max. displacement	○	○
B	Adjustable limiters set to 96% of max. displacement	○	○
C	Adjustable limiters set to 92% of max. displacement	○	○
D	Adjustable limiters set to 88% of max. displacement	○	○
E	Adjustable limiters set to 84% of max. displacement	○	○
F	Adjustable limiters set to 80% of max. displacement	○	○

Code	Description	41	51
<b>NFPH Control</b>			
0	None	●	●
1	Adjustable limiters set to max. displacement	○	○
2	Adjustable limiters set to 96% of max. displacement	○	○
3	Adjustable limiters set to 92% of max. displacement	○	○

**Model Code**

<b>Code</b>	<b>Description</b>	<b>41</b>	<b>51</b>
<b>4</b>	Adjustable limiters set to 88% of max. displacement	○	○
<b>5</b>	Adjustable limiters set to 84% of max. displacement	○	○
<b>6</b>	Adjustable limiters set to 80% of max. displacement	○	○

**Model Code**

**Model Code: C, F, S**

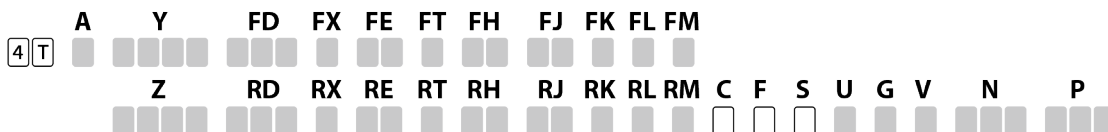

(● = Standard, ○ = Optional)

*C - Shaft*

Code	Description	41	51
D	15 teeth 16/32 pitch	○	○
E	19 teeth 16/32 pitch	●	●

*F - Housing*

Code	Description	41	51
3	MDC - Standard	●	●
5	NFPH - Standard	●	●

*S - Charge Pressure Relief Setting*

Code	Description	41	51
C	14 bar (203 psi)	○	○
D	16 bar (232 psi)	○	○
E	18 bar (261 psi)	○	○
F	20 bar (290 psi)	●	●
G	22 bar (319 psi)	○	○
H	24 bar (348 psi)	○	○
N	None	○	○
P	Defeated	○	○
R	14 bar (203 psi), Anti-stall	○	○
T	16 bar (232 psi), Anti-stall	○	○
V	18 bar (261 psi), Anti-stall	○	○
W	20 bar (290 psi), Anti-stall	○	○
X	22 bar (319 psi), Anti-stall	○	○
Z	24 bar (348 psi), Anti-stall	○	○

**Model Code**

**Model Code: U, G, V**

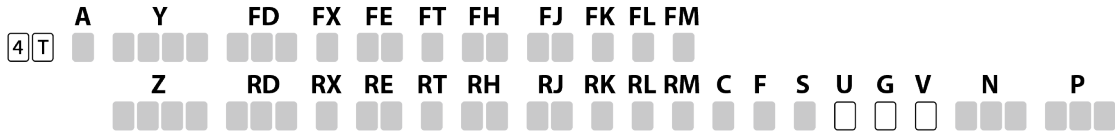

(● = Standard, ○ = Optional)

*U - Auxiliary Mounting Pad*

Code	Description	41	51
D	Rev B-Pad-Special, 90 and 270 deg gear pump orient, 11 tooth, ship cover	○	○
E	Rev B-Pad, 0 and 180 deg gear pump orient, 13 tooth, ship cover	○	○
J	SAE A 9T, All gear pump orientations, ship cover	○	○
K	SAE A 11T, All gear pump orientations, ship cover	●	●
L	SAE B 13T, 0 and 180 deg gear pump orientations, ship cover	●	●
Q	AUX Pad-none, 4T (U000Q)	●	●
S	AUX Pad-SAE A 13T, Ship cover, 4T (U000S)	○	○
R	SAE B, 13T, 0 and 180 deg gear pump orientations, ship cover	○	○
T	Rev B-Pad-Special, 90 and 270 deg gear pump orient, 13 tooth, ship cover	○	○

*G - Gear Pump*

Code	Description	41	51
N	None	●	●

*V - Gear Pump Orientation*

Code	Description	41	51
N	Not Applicable	●	●



**Model Code**

**Model Code: N, P**

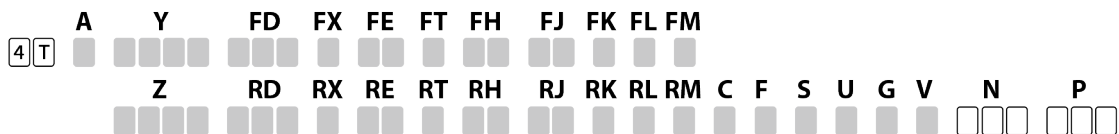

(● = Standard, ○ = Optional)

*N - Special Hardware*

Code	Description	41	51
NNR	None, CW rotation	●	●
NNL	None, CCW rotation	○	○

*P - Special Feature Description (Non-Hardware)*

Code	Tag Text Layout					Tag/Logo	
N - Black (Standard)	N	Line 1	Line 2	Line 3	Line 4	Line 5	N - Danfoss Logo
		Order code (Standard)	Order code	Order code	Model #	Model #	

**Products we offer:**

- Cartridge valves
- DCV directional control valves
- Electric converters
- Electric machines
- Electric motors
- Gear motors
- Gear pumps
- Hydraulic integrated circuits (HICs)
- Hydrostatic motors
- Hydrostatic pumps
- Orbital motors
- PLUS+1® controllers
- PLUS+1® displays
- PLUS+1® joysticks and pedals
- PLUS+1® operator interfaces
- PLUS+1® sensors
- PLUS+1® software
- PLUS+1® software services, support and training
- Position controls and sensors
- PVG proportional valves
- Steering components and systems
- Telematics

**Danfoss Power Solutions** is a global manufacturer and supplier of high-quality hydraulic and electric components. We specialize in providing state-of-the-art technology and solutions that excel in the harsh operating conditions of the mobile off-highway market as well as the marine sector. Building on our extensive applications expertise, we work closely with you to ensure exceptional performance for a broad range of applications. We help you and other customers around the world speed up system development, reduce costs and bring vehicles and vessels to market faster.

Danfoss Power Solutions – your strongest partner in mobile hydraulics and mobile electrification.

**Go to [www.danfoss.com](http://www.danfoss.com) for further product information.**

We offer you expert worldwide support for ensuring the best possible solutions for outstanding performance. And with an extensive network of Global Service Partners, we also provide you with comprehensive global service for all of our components.

Local address:

**Hydro-Gear**

[www.hydro-gear.com](http://www.hydro-gear.com)

**Daikin-Sauer-Danfoss**

[www.daikin-sauer-danfoss.com](http://www.daikin-sauer-danfoss.com)

**Danfoss  
Power Solutions (US) Company**  
2800 East 13th Street  
Ames, IA 50010, USA  
Phone: +1 515 239 6000

**Danfoss  
Power Solutions GmbH & Co. OHG**  
Krokamp 35  
D-24539 Neumünster, Germany  
Phone: +49 4321 871 0

**Danfoss  
Power Solutions ApS**  
Nordborgvej 81  
DK-6430 Nordborg, Denmark  
Phone: +45 7488 2222

**Danfoss  
Power Solutions Trading  
(Shanghai) Co., Ltd.**  
Building #22, No. 1000 Jin Hai Rd  
Jin Qiao, Pudong New District  
Shanghai, China 201206  
Phone: +86 21 2080 6201

Danfoss can accept no responsibility for possible errors in catalogues, brochures and other printed material. Danfoss reserves the right to alter its products without notice. This also applies to products already on order provided that such alterations can be made without subsequent changes being necessary in specifications already agreed. All trademarks in this material are property of the respective companies. Danfoss and the Danfoss logotype are trademarks of Danfoss A/S. All rights reserved.