

Data sheet

# Indirect servo-operated 2/2-way solenoid valves

## Type EV220W 10 - EV220W 50, NBR and EPDM versions



EV220W is a range of compact indirect servo-operated 2/2 way solenoid valves with connections from 3/8" to 2", especially designed for use within a limited space.

This range has been designed for use within various markets, such as, the Industrial and HVAC markets, which demand an easy and reliable valve that is easy to setup and use.

### Features and versions

- For water, oil, compressed air and similar neutral media
- NBR for air and oil
- EPDM for water and brine
- WRAS approved with EPDM sealing;
  - 0 – 90 °C NC version
  - 0 – 50 °C NO version
- DN 10 – 50
- Differential pressure: From 0.2 – 10 bar
- Media temperatures: From -30 – 100 °C
- Viscosity: Up to 50 cSt
- Ambient temperatures: From -40 – 50 °C
- Standard equipped with clip on coil for dry and humid environments
- Enclosure: IP65
- NC version, standard for 3/8" – 2" valve sizes
- NO version, standard for 3/8" – 2" valve sizes
- Complete coil voltage: 230 V AC, 24V AC, 24 V DC

Brass valve body, NC.  
NBR seal.  
Clip on coil and cable plug



- In accordance with:
  - Low Voltage Directive 2014/35/EU
  - EN60730-1
  - EN60730-2-8
 (Notified body by Semko)
  - Pressure Equipment Directive 2014/68/EU
  - RoHS Directive 2011/65/EU

Connection ISO228/1	Seal material	Orifice size	K <sub>v</sub> - value	Media temperature	Differential pressure min. to max.	Coil voltage/power consumption AS coil	Code no.
		[mm]	[m <sup>3</sup> /h]	[°C]	[bar]		
G 3/8	NBR	10	1.6	-10 – 60	0.2 – 10	230V 50/60Hz 8W	042U426132
						24V 50/60Hz 9.5W	042U426119
						24V DC 6.5W	042U426102
G 1/2		14	4	-10 – 60	0.3 – 10	230V 50/60Hz 8W	042U426432
						24V 50/60Hz 9.5W	042U426419
						24V DC 6.5W	042U426402
G 3/4		18	7	-10 – 60	0.3 – 10	230V 50/60Hz 8W	042U426532
						24V 50/60Hz 9.5W	042U426519
						24V DC 6.5W	042U426502
G 1		22	7	-10 – 60	0.3 – 10	230V 50/60Hz 8W	042U426632
	24V 50/60Hz 9.5W					042U426619	
	24V DC 6.5W					042U426602	
G 1 1/4	32	15	-10 – 60	0.3 – 10	230V 50/60Hz 8W	042U426732	
					24V 50/60Hz 9.5W	042U426719	
					24V DC 6.5W	042U426702	
G 1 1/2	40	18	-10 – 60	0.3 – 10	230V 50/60Hz 8W	042U426832	
					24V 50/60Hz 9.5W	042U426819	
					24V DC 6.5W	042U426802	
G 2	50	32	-10 – 60	0.3 – 10	230V 50/60Hz 8W	042U426932	
					24V 50/60Hz 9.5W	042U426919	
					24V DC 6.5W	042U426902	

<sup>1)</sup> It is recommended to use a filter in front of the valve.

<sup>2)</sup> In water applications, exercise the valves at least once every 24 hours, meaning change the state of the valve. The valve exercise will minimize the risk of the valve sticking due to calcium carbonate, zinc or iron oxide build-up.

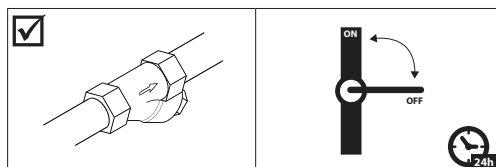

<sup>3)</sup> In heating applications it is recommended that the Water Oxygen content should not exceed 0.1mg / L in the temperature range 40 – 60 °C. Operating in such conditions may reduce valve lifetime.

Data sheet | Indirect servo-operated 2/2-way solenoid valves, Type EV220W 10 - EV220W 50

Brass valve body, NO.  
NBR seal.  
Clip on coil and cable plug

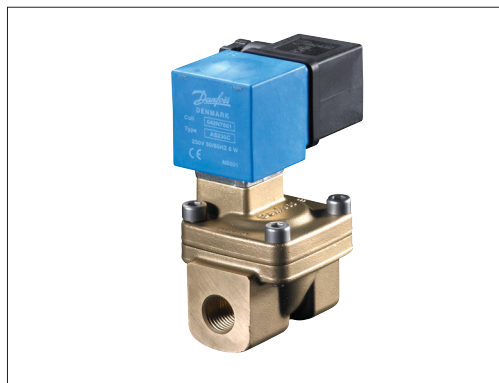

- In accordance with:
  - Low Voltage Directive 2014/35/EU
  - EN60730-1
  - EN60730-2-8
 (Notified body by Semko)
  - Pressure Equipment Directive 2014/68/EU
  - RoHS Directive 2011/65/EU

Connection ISO228/1	Seal material	Orifice size	K <sub>v</sub> - value	Media temperature	Differential pressure min. to max.	Coil voltage/power consumption AS coil	Code no.
		[mm]	[m <sup>3</sup> /h]	[°C]	[bar]		
G 3/8	NBR	10	1.6	-10 – 60	0.2 – 10	230V 50/60Hz 8W	042U436132
						24V 50/60Hz 9.5W	042U436119
						24V DC 6.5W	042U436102
G 1/2		14	4	-10 – 60	0.3 – 10	230V 50/60Hz 8W	042U436432
						24V 50/60Hz 9.5W	042U436419
						24V DC 6.5W	042U436402
G 3/4		18	7	-10 – 60	0.3 – 10	230V 50/60Hz 8W	042U436532
						24V 50/60Hz 9.5W	042U436519
						24V DC 6.5W	042U436502
G 1		22	7	-10 – 60	0.3 – 10	230V 50/60Hz 8W	042U436632
						24V 50/60Hz 9.5W	042U436619
						24V DC 6.5W	042U436602
G 1 1/4	32	15	-10 – 60	0.3 – 10	230V 50/60Hz 8W	042U436732	
					24V 50/60Hz 9.5W	042U436719	
					24V DC 6.5W	042U436702	
G 1 1/2	40	18	-10 – 60	0.3 – 10	230V 50/60Hz 8W	042U436832	
					24V 50/60Hz 9.5W	042U436819	
					24V DC 6.5W	042U436802	
G 2	50	32	-10 – 60	0.3 – 10	230V 50/60Hz 8W	042U436932	
					24V 50/60Hz 9.5W	042U436919	
					24V DC 6.5W	042U436902	

<sup>1)</sup> It is recommended to use a filter in front of the valve.

<sup>2)</sup> In water applications, exercise the valves at least once every 24 hours, meaning change the state of the valve. The valve exercise will minimize the risk of the valve sticking due to calcium carbonate, zinc or iron oxide build-up.

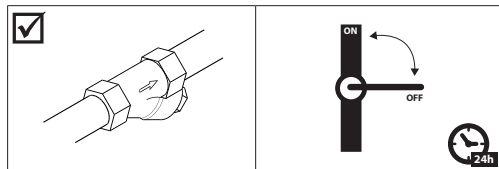

Data sheet | Indirect servo-operated 2/2-way solenoid valves, Type EV220W 10 - EV220W 50

Brass valve body, NC.  
EPDM seal.  
Clip on coil and cable plug



- WRAS ; see below, 0 - 90 °C
- In accordance with:
  - Low Voltage Directive 2014/35/EU
  - EN60730-1
  - EN60730-2-8
 (Notified body by Semko)
  - Pressure Equipment Directive 2014/68/EU
  - RoHS Directive 2011/65/EU

Conne- ction ISO228/1	Seal material	Orifice size	K <sub>v</sub> - value	Media temperature	Differential pressure min. to max.	Conformity	Coil voltage/ power consump- tion AS coil	Code no.
		[mm]	[m <sup>3</sup> /h]	[°C]	[bar]			
G 3/8	EPDM	10	1.6	-30 – 100	0.2 – 10		230V 50/60Hz 8W	042U471032
							24V 50/60Hz 9.5W	042U471019
							24V DC 6.5W	042U471002
G 1/2		14	4	-30 – 100	0.3 – 10		230V 50/60Hz 8W	042U471432
							24V 50/60Hz 9.5W	042U471419
							24V DC 6.5W	042U471402
G 3/4		18	7	-30 – 100	0.3 – 10		230V 50/60Hz 8W	042U471832
							24V 50/60Hz 9.5W	042U471819
							24V DC 6.5W	042U471802
G 1		22	7	-30 – 100	0.3 – 10		230V 50/60Hz 8W	042U472232
							24V 50/60Hz 9.5W	042U472219
							24V DC 6.5W	042U472202
G 1 1/4	32	15	-30 – 100	0.3 – 10		230V 50/60Hz 8W	042U473232	
						24V 50/60Hz 9.5W	042U473219	
						24V DC 6.5W	042U473202	
G 1 1/2	40	18	-30 – 100	0.3 – 10		230V 50/60Hz 8W	042U474032	
						24V 50/60Hz 9.5W	042U474019	
						24V DC 6.5W	042U474002	
G 2	50	32	-30 – 100	0.3 – 10	 Pending	230V 50/60Hz 8W	042U475032	
						24V 50/60Hz 9.5W	042U475019	
						24V DC 6.5W	042U475002	

<sup>1)</sup> WRAS approved in the temperature range 0 – 90 °C.

<sup>2)</sup> It is recommended to use a filter in front of the valve.

<sup>3)</sup> In water applications, exercise the valves at least once every 24 hours, meaning change the state of the valve.  
The valve exercise will minimize the risk of the valve sticking due to calcium carbonate, zinc or iron oxide build-up.

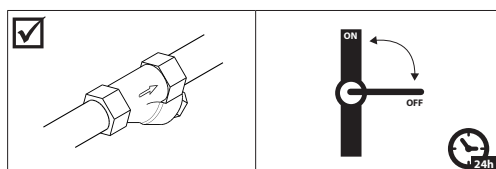

Data sheet | Indirect servo-operated 2/2-way solenoid valves, Type EV220W 10 - EV220W 50

Brass valve body, NO.  
EPDM seal.  
Clip on coil and cable plug



- WRAS ; see below, 0 - 50 °C
- In accordance with:
  - Low Voltage Directive 2014/35/EU
  - EN60730-1
  - EN60730-2-8
 (Notified body by Semko)
  - Pressure Equipment Directive 2014/68/EU
  - RoHS Directive 2011/65/EU

Conne- ction ISO228/1	Seal material	Orifice size	K <sub>v</sub> - value	Media temperature	Differential pressure min. to max.	Conformity	Coil voltage/ power consump- tion AS coil	Code no.
		[mm]	[m <sup>3</sup> /h]	[°C]	[bar]			
G 3/8	EPDM	10	1.6	-30 – 100	0.2 – 10		230V 50/60Hz 8W	042U413032
						Pending	24V 50/60Hz 9.5W	042U413019
							24V DC 6.5W	042U413002
G 1/2		14	4	-30 – 100	0.3 – 10		230V 50/60Hz 8W	042U413332
						Pending	24V 50/60Hz 9.5W	042U413319
							24V DC 6.5W	042U413302
G 3/4		18	7	-30 – 100	0.3 – 10		230V 50/60Hz 8W	042U413432
						Pending	24V 50/60Hz 9.5W	042U413419
							24V DC 6.5W	042U413402
G 1		22	7	-30 – 100	0.3 – 10		230V 50/60Hz 8W	042U413532
	Pending					24V 50/60Hz 9.5W	042U413519	
						24V DC 6.5W	042U413502	
G 1 1/4	32	15	-30 – 100	0.3 – 10		230V 50/60Hz 8W	042U413632	
					Pending	24V 50/60Hz 9.5W	042U413619	
						24V DC 6.5W	042U413602	
G 1 1/2	40	18	-30 – 100	0.3 – 10		230V 50/60Hz 8W	042U413732	
					Pending	24V 50/60Hz 9.5W	042U413719	
						24V DC 6.5W	042U413702	
G 2	50	32	-30 – 100	0.3 – 10		230V 50/60Hz 8W	042U413832	
					Pending	24V 50/60Hz 9.5W	042U413819	
						24V DC 6.5W	042U413802	

<sup>1)</sup> WRAS approved in temperature range 0 – 50 °C.

<sup>2)</sup> It is recommended to use a filter in front of the valve.

<sup>3)</sup> In water applications, exercise the valves at least once every 24 hours, meaning change the state of the valve.  
The valve exercise will minimize the risk of the valve sticking due to calcium carbonate, zinc or iron oxide build-up.

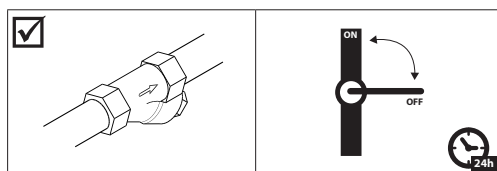

**Data sheet | Indirect servo-operated 2/2-way solenoid valves, Type EV220W 10 - EV220W 50**
**Technical data, NC and NO**

Type	EV220W 10	EV220W 14	EV220W 18	EV220W 22	EV220W 32	EV220W 40	EV220W 50
Time to open [ms] <sup>1)</sup>	50	100	200	200	2500	4000	5000
Time to close [ms] <sup>1)</sup>	300	400	500	500	4000	6000	10000
Capacity, K <sub>v</sub> [m <sup>3</sup> /h]	1.6	4	7	7	15	18	32

<sup>1)</sup> Times are indicative and apply to water. Exact times will depend on pressure conditions.

<b>Max working pressure (MWP)</b>	10 bar		
<b>Max test pressure</b>	EV220W 10-50	15	
<b>Medium viscosity</b>	Max. 50cSt		
<b>Materials</b>	Valve body	Brass	W. no. 2.0401
	Armature	Stainless steel	W. no. 1.4105 / AISI 430FR
	Armature stop	Stainless steel	W. no. 1.4105 / AISI 430FR
	Armature tube	Stainless steel	W. no. 1.4303 / AISI 305
	Spring	Stainless steel	W. no. 14310 / AISI 301
	O-ring	NBR / EPDM	
	Valve plate	NBR / EPDM	
Diaphragm	NBR / EPDM		

**Dimensions and weight:**

Type	Weight with AS coil [kg]	L [mm]	L <sub>1</sub> [mm]	B [mm]	B <sub>1</sub> [mm]	H <sub>1</sub> [mm]	H [mm]	
					Coil AS		NC	NO
EV220W 10	0.56	51	50	50	70	13	77	81
EV220W 14	0.62	58	50	58	70	13	78	82
EV220W 18	0.84	90	50	58	70	18	79	83
EV220W 22	1.12	90	50	58	70	22	84	84
EV220W 32	2.12	120	50	82	70	27	96	96
EV220W 40	3.32	130	50	95	70	32	106	106
EV220W 50	4.42	162	50	113	70	37	112	112

**Dimensions**

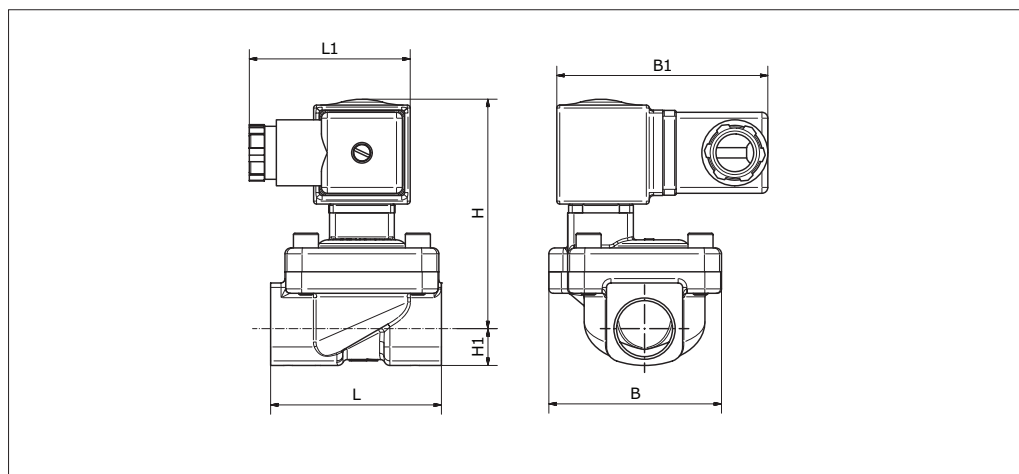

**Mounting angle**

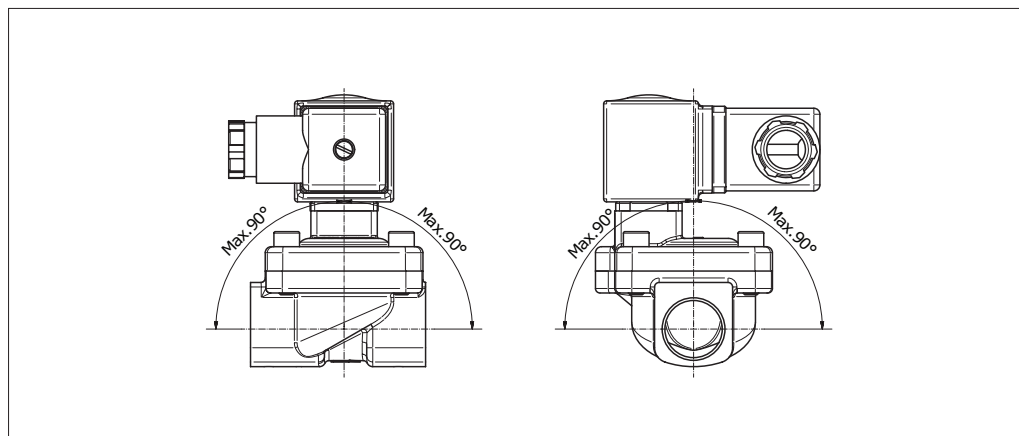

AS/AZ,  
Compact UL recognised,  
clip-on coils



- Enclosure:  
Up to IP65 / NEMA 4
- Used with EV220W
- In accordance with:
  - RoHS Directive 2011/65/EU
  - Low Voltage Directive 2014/35/EU
  - EN60730-1
  - EN60730-2-8
- UL recognized

Type	Ambient temperature	Supply voltage	Voltage variation	Frequency	Power consumption		Code no.
	[°C]				[V]	[Hz]	
AS024CS	-40 - 50	24	-10%, +6%	50	9.5	18	042N7608
		24	-10%, +6%	60	7.0	14	
AS230CS	-40 - 50	230	-10%, +6%	50	8.0	16	042N7601
		208 - 240	±6%	60	7.0	14	
AZ012DS	-40 - 50	12	-10%, +6%	DC	6.0	-	042N7616
AZ024DS	-40 - 50	24	-10%, +6%	DC	6.5	-	042N7617

Technical data

Design	In accordance with UL 429
Insulation of coil windings	Class H according to IEC 85
Connection	Spade connector in accordance with DIN 43650 form A
Enclosure, IEC 529	IP00 with DIN spade connector, IP65 with cable plug
Plug type	Cable plug (042N0156)

Dimensions and weight

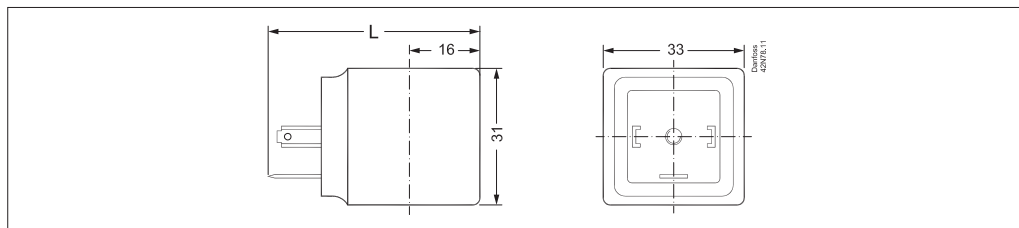

L without cable plug	L with cable plug	L with protective cap	Weight
[mm]	[mm]	[mm]	[kg]
48	72	64	0.10

Accessories:  
Cable plug

Type, Form A	Code no.
GDM 2011 (grey) cable plug according to DIN 43650-A PG11	042N0156

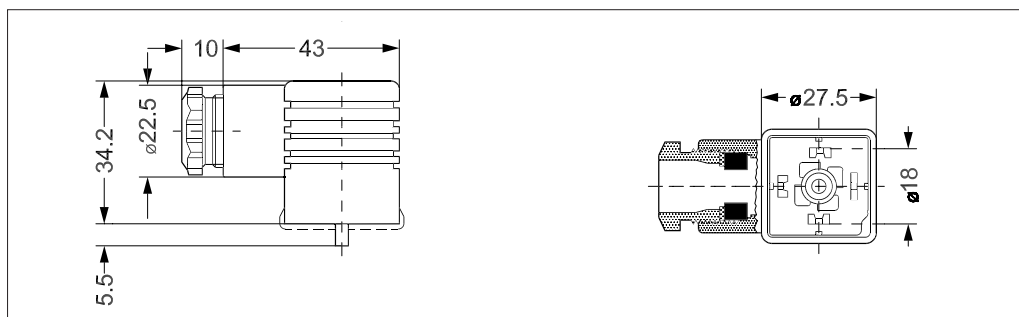



**Function, NC**

- 1. Coil
- 2. Armature spring
- 3. Armature
- 4. Pilot orifice
- 5. Diaphragm
- 6. Equalizing orifice
- 7. Main orifice

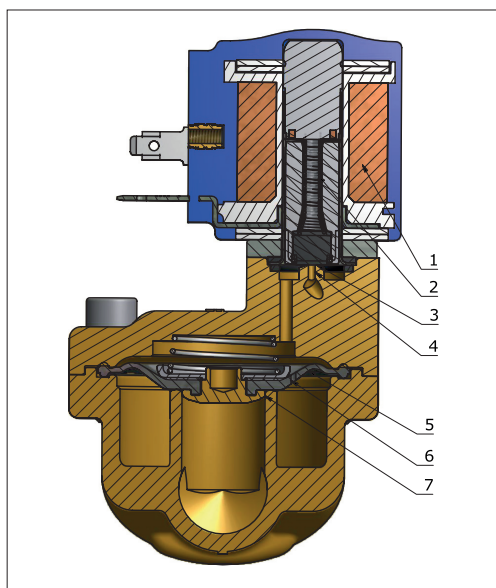

**Coil voltage disconnected**

When voltage is disconnected, the armature spring (2) presses the armature (3) down against the pilot orifice (4). Pressure builds up over the diaphragm (5) via the equalizing orifice (6). The diaphragm closes the main orifice (7) as soon as the pressure over the diaphragm equals the inlet pressure. The valve stays closed for as long as voltage remains disconnected.

**Coil voltage connected (open)**

When voltage is applied to the coil (1), the pilot orifice (4) is opened. Since the pilot orifice is larger than the equalizing orifice (6), pressure over the diaphragm (5) falls and the diaphragm is lifted clear of the main orifice (7). The valve stays open for as long as the required minimum differential pressure is present and voltage is applied to the coil.

**Function, NO**

- 1. Coil
- 2. Armature spring
- 3. Armature
- 4. Pilot orifice
- 5. Diaphragm
- 6. Equalizing orifice
- 7. Main orifice

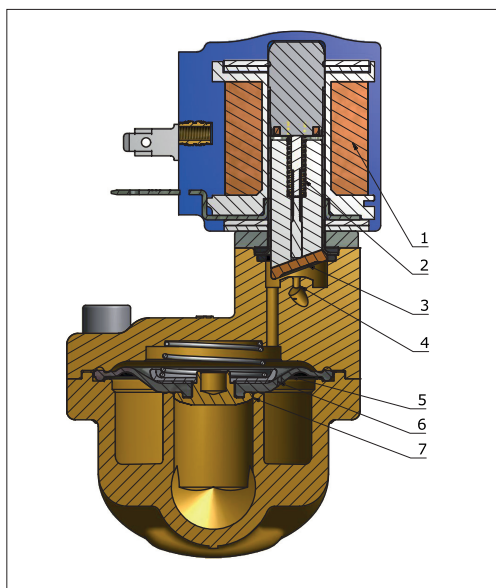

In principle the function involves the opposite valve positions to those above for applied and disconnected voltage respectively.

### Capacity diagram

Example for water:  
Capacity for EV220W at a differential  
pressure of 3 bar: Approx. 7 m<sup>3</sup>/h

