

ENGINEERING
TOMORROW



User Guide

Motor / Generator

EM-PMI540-T1500

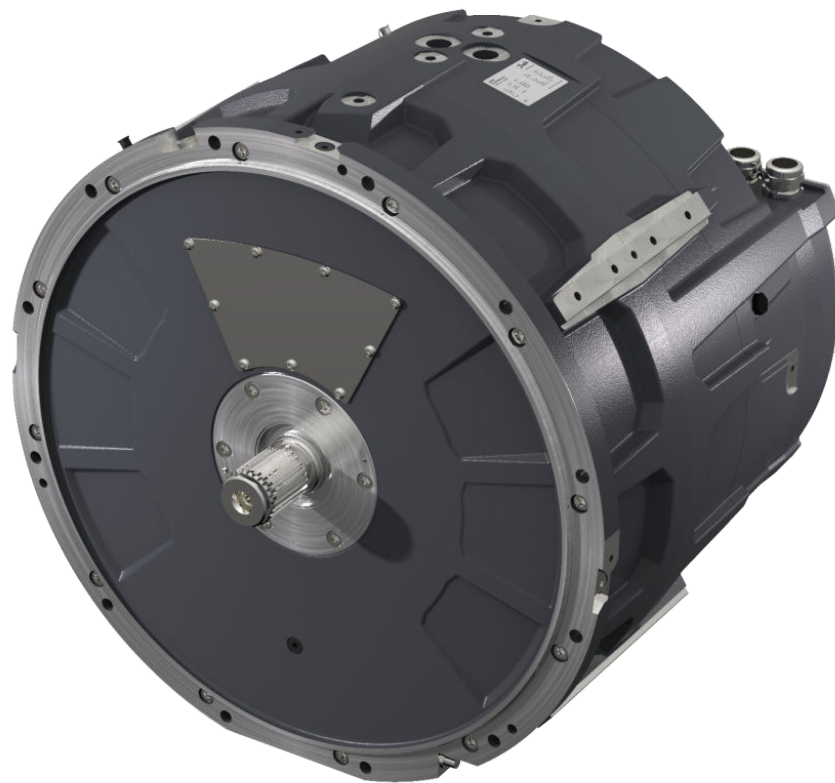

Revision history

Table of revisions

Date	Changed	Rev
May 2024	Sections updated: Shaft alignment and load, Storage, Condition monitoring during operation, Service parts	0204
March 2024	Sections updated: High voltage connection (graphics updated), Cable gland assembly and power line connection (table Cable gland alternatives updated). Section added: Measuring the insulation resistance	0203
April 2023	Minor modifications and improvements	0202

Contents

General information

Intended use of the user guide.....	5
Product naming convention	5
Conformity according to standards.....	7
Warranty.....	7
Terms and abbreviations.....	7
Responsibility of the manufacturer.....	8

Safety information

General safety statement.....	9
Safety message signal words.....	9
Safety symbols.....	9
Personal protective equipment.....	10
Security features.....	10
Electromagnetic compatibility (EMC).....	11

Product overview

Intended use of the electric machine.....	13
Used technology.....	14
System introduction.....	15
Connections and interfaces.....	16
Rating plate.....	18
Tightening torques.....	19

Design principles

System design.....	20
Cooling and temperature measurement	20
Insulation lifetime.....	20
Inverter.....	21
Mounting structure.....	22
Supporting structure requirements.....	22
Shaft alignment and load.....	23

Transportation and storage

Transportation.....	26
Receiving and unpacking.....	26
Lifting.....	26
Storage.....	28
Extended storage.....	29

Installation

Required tools.....	31
Insulation resistance test.....	31
Mechanical installation.....	33
Allowed mounting positions.....	33
Mounting the electric machine.....	35
Cooling connections.....	38
Electrical installation.....	39
Power connections.....	39
High voltage connection.....	39
Connection diagram.....	41
Cable gland assembly and power line connection.....	42
Low voltage connections.....	48
Grounding connections.....	52
Anti-condensation heater connections.....	55

Operation

Operation conditions.....	58
Condition monitoring during operation.....	58
Recommended lubricants.....	59
Recommended coolants.....	59
Emergency operation.....	59

Contents

Maintenance

Regular maintenance.....	61
Cleaning.....	62
Bearings and lubrication.....	63
Cooling system maintenance.....	66

Dismounting

Troubleshooting

Aftersales

Service policy.....	70
Service parts.....	70

Disposal

Storage, installation and maintenance checklists

General information

This user guide is the installation, operation and maintenance user guide for the EM-PMI540-T1500 electric machine.

Intended use of the user guide

This user guide contains instructions necessary to safely and properly handle, install, operate and maintain the electric machine. They should be brought to the attention of anyone who installs, operates or maintains the machine or associated equipment.

All of the safety warnings and instructions in this user guide must be followed to prevent injury to personnel or damage to property. Only qualified and authorized personnel, familiar with health and safety requirements and national legislation, shall be permitted to handle, install, operate and maintain the device.

This user guide must be kept for future reference during installation, operation and maintenance.

This user guide uses illustrations as examples only. Illustrations in this user guide may not necessarily reflect all system features.

Product naming convention

In this user guide, EM-PMI family permanent magnet motors and generators are referred to as the electric machine.

Frame model indicates dimensions and electrical characteristics of the electric machine. The following naming convention is used to refer to the electric machine frame model:

- EM-PMI540-T1500-XXXX+XX

The naming codes of the electric machine

Part of the name	Meaning
EM	Electric Machine
PMIXXX or PMEXXX	Permanent Magnet Internal and a number relative to the diameter of the electric machine, or Permanent Magnet External and a number relative to diameter of the electric machine
TXXXX	Average continuous torque of the motor range, relative to the length of the machine
XXXX	Rated rotation speed
+XX	Options. Standard options are indicated by a star (*).

The power input of the machine may require one or several three phase power systems. This is indicated by a power connection option marking, for example: DUAL or QUAD in the machine model code. One three phases power system can include one or three connection boxes in the machine. The most usual case is when an electric machine has a single connection box, but this is not shown in the machine model code.

- Example: EM-PMI540-T1500-1200-DUAL

The electric machine can include some of the options available. The options of the electric machine are shown also in the rating plate, following the frame model code. Note! Only options that differ from the standard delivery are indicated. For detailed information on the models, options and characteristics, see product-specific data sheet.

General information

EM-PMI540-T1500 options

Variant	Code	Description	Additional information
High voltage connections	-DUAL	Two galvanically isolated 3 phase systems	Two connection boxes each containing one 3 phase system with one M32 cable gland per phase
Low voltage connections	*	Low voltage connections done with connector	DEUTSCH HD34-24-47PE connector for LV connections
	+LVB1	Low voltage connections done with connection box and terminal strip	Connection box with 2 x M25 cable glands (reserve 2x plugged M16 threads available) and terminal block for LV connections
Connection extension	*	None	Two connection boxes each containing one 3 phase system with two M32 cable glands per phase
	+CE1	Double phase connections	Extended connection boxes with two M32 cable glands per phase
N-end attachment	*	None	
	+NE4	Male shaft, no flange	DIN5480 W55x2x26x8a, D-end axle length increases from 80 mm to 100 mm with +NE4 option
Foot mounting	*	None	
	+FM1	Foot	Foot mounting, shaft height 315 mm
Bearing insulation	*	Non-insulated bearings	Non-insulated bearings
	+BIN	Insulated bearing in N-end	Insulated bearing in N-end
	+BIA	Insulated bearing in both ends	Insulated bearing in both ends
Shaft grounding	*	None	No shaft grounding
	+SG1	D-end shaft grounding	In-built grounding ring
Rotation sensor (resolver)	*	None	No resolver
	+RES1	Resolver	Inbuilt non-contacting resolver, 8-pole pair
Winding temperature sensor	*	Temperature surveillance	3 x PT100 (two wire) in windings
	+TEMP4	Redundant temperature surveillance	6 x PT100 (two wire) in windings
	+TEMP5	Redundant temperature surveillance	12 x PT100 (two wire) in windings
Bearing temperature sensor	*	None	
	+BTMP1	PT100 in bearings	Plug-in connector
Anti-condensation heaters	*	None	
	+HEAT1	One anti-condensation heater	230 V _{AC} / 130 W
Marine classification	*	No marine classification	
	+CL1		ABS American Bureau of Shipping
	+CL2		BV Bureau Veritas
	+CL3		DNV
	+CL4		LR Lloyd's Register
	+CL5		RINA
	+CL6		CCS China Classification Society

General information

Conformity according to standards

The electric machine has been designed to be in conformity with the following directives and to meet the requirements specified in the following standards:

Applicable Directives and standards

Standard	Explanation
Low Voltage Directive 2006/95/EC (until 19.4.2016) and Low Voltage Directive 2014/35/EU (from 20.4.2016 onwards)	Electrical equipment means any equipment designed for use with a voltage rating of between 50 and 1000 V for alternating current. This electric machine is subject to the Low Voltage Directive 2006/95/EC or 2014/35/EC.
IEC 60034-1:2010	Rotating electrical machines - Part 1: Rating and performance
IEC 60034-5:2001/A1:2007	Rotating electrical machines - Part 5: Degrees of protection provided by the integral design of rotating electrical machines (IP code) - Classification
IEC 60034-6:1991	Rotating electrical machines - Part 6: Methods of cooling
IEC 60034-7:1992/A1:2001	Rotating electrical machines - Part 7: Classification of types of construction, mounting arrangements and connection box position (IM Code)
IEC 60034-8:2007/A1:2014	Rotating electrical machines - Part 8: Terminal markings and direction of rotation
IEC 60034-14:2004/A1:2008	Amendment 1 - Rotating electrical machines - Part 14: Mechanical vibration of certain machines with shaft heights 56 mm and higher - Measurement, evaluation and limits of vibration severity.

It should be noted, that the commissioning party is responsible for establishing the conformity of the end product with the Directive 2006/42/EC, when the EM-PMI electric machines are fitted into machinery.

Warranty

Danfoss offers warranty against defects in workmanship and materials for its products for a period of twelve (12) months from commissioning or eighteen months (18) from delivery (Incoterms-EXW), whichever occurs first.

In order for the warranty to be valid, the customer must follow the requirements of this and all related documents, especially those set out in the product installation and maintenance, as well as the applicable standards and regulations in force in each country.

Defects arising from the improper or negligent use, operation, and/or installation of the equipment, non-execution of regular preventive maintenance, as well as defects resulting from external factors or equipment and components not supplied/recommended by Danfoss, will not be covered by the warranty.

The warranty will not apply if the customer at its own discretion makes repairs and/or modifications to the equipment without prior written consent from Danfoss.

Terms and abbreviations

The symbols, terms and abbreviations in the Tables below are possibly used in this manual.

Symbols

Symbol	Variable	Unit
U	Rated voltage (phase-to-phase AC)	V_{rms}
I	Rated current (AC)	A_{rms}
P	Rated Power (S1)	kW
T	Rated torque (S1) at rated speed	Nm
T_{max}	Maximum torque	Nm

General information

Symbols (continued)

Symbol	Variable	Unit
n	Rated speed	rpm
$Max\ n$	Maximum speed	rpm
f	Rated supply frequency at nominal speed	Hz
PF	Power factor ($\cos\phi$)	
Q_c	Rated coolant liquid flow	l/min
T_c	Rated coolant liquid input temperature	°C
T_{amb}	Rated ambient temperature	°C
RES_COS	Cosine signal received from the resolver	deg
RES_SIN	Sinusoidal signal received from the machine resolver	deg
Ω (Ohm)	Resistance	Ω

Term / abbreviation

Term/ Abbreviation	Explanation
Resolver	Rotation meter in electric machines, used for measuring degrees of rotation
AC	Alternating current
DC	Direct current
GND	Ground in electrical connections
PMSM	Permanent Magnet Synchronous Machine
SRPM	Synchronous Reluctance assisted Permanent Magnet
S1	Duty type according to the IEC60034; Continuous running duty
S9	Duty type according to the IEC60034; Duty with non-periodic load and speed variations

Responsibility of the manufacturer

Danfoss is responsible for the safety, reliability and performance of the electric machine only if:

- Handling, mounting, installation, operation and maintenance are done by qualified and authorized personnel.
- The installation of the system complies with the requirements of the appropriate regulations.
- The electric machine is used in accordance with the instructions in this user guide.
- The electric machine is installed, maintained and serviced in accordance with the instructions in this user guide.

Safety information

General safety statement

- The electric machine is intended for use as a component for industrial and commercial installations. The end product containing the electric machine must conform with all related regulations.
- The use of the electric machine is prohibited in hazardous areas unless it is expressly designed for such use.
- The electric machine is intended for installation, use and maintenance by qualified personnel, familiar with health and safety requirements and national legislation. Ignoring these instructions may invalidate all applicable warranties.
- These instructions must be followed to make sure of safe and correct installation, operation and maintenance of the electric machine. They should be brought to the attention of anyone who installs, operates or maintains the electric machine or associated equipment.
- High voltage and rotating parts can cause serious or fatal injuries. For electric machine covered by this user guide, it is important to observe safety precautions to protect personnel from possible injury.

Safety message signal words

Safety message signal words indicate the severity of a potential hazard.

DANGER Indicates an imminently hazardous situation which, if not avoided, will result in death or serious injury.

WARNING Indicates a potentially hazardous situation which, if not avoided, could result in death or serious injury.

CAUTION Indicates a potentially hazardous situation which, if not avoided, may result in minor or moderate injury. CAUTION may also alert against unsafe practices.

NOTICE Indicates a potentially hazardous situation which, if not avoided, could result in property damage.

Safety symbols

The following safety and information related symbols appear in this user guide and on the electric machine.

	<p>Danger This symbol is identified by a yellow background, red octagonal band and a black STOP text. It indicates a hazardous situation that causes severe injury or death. Action indicated by this symbol may not be executed.</p>
	<p>General warning This symbol is identified by a yellow background, black triangular band, and a black exclamation point symbol. It indicates a general potentially hazardous situation.</p>
	<p>Electric shock warning The symbol is identified by a yellow background, black triangular band, and a black arrowhead symbol. It indicates dangerous electrical voltage that could cause an electric shock to a person.</p>
	<p>Burn warning The symbol is identified by a yellow background, black triangular band, and a black wavy lines symbol. It indicates a hot device that could cause burns to a person. The symbol also indicates that the device should be placed and installed so that contact with its potentially hot surface is not possible.</p>

Safety information

	<p>Magnet warning The symbol is identified by a yellow background, black triangular band, and a black magnet symbol. It indicates strong magnetic field that could cause harm to a person or property.</p>
	<p>Rotating shaft warning The symbol is identified by a yellow background, black triangular band, and a black rotating shaft symbol. It indicates strong rotating shaft that could cause harm to a person or property.</p>
	<p>General Information.</p>
	<p>Read the instructions in the user guide.</p>

Personal protective equipment

Personal protective equipment shall be used when necessary during handling, installation and maintenance of the electric machine to avoid injury.

	<p>Use eye protective equipment like safety goggles or mask when you work with the electric machine. Permanent damage to the eye could be caused if bearing grease, melted nitrile rubber (radial lip seal), glycol or other fluids splash.</p>
	<p>Use hearing protective equipment when you work on the electric machine. Hearing injuries can be caused by too loud noise (noise in excess of 85 dBA).</p>
	<p>Use head protective equipment like helmet when you lift the electric machine! Head injuries can be caused by object impact.</p>
	<p>Use cut resistant gloves when you handle and maintain the electric machine. There is a risk of cut injuries.</p>
	<p>Use protective footwear when you lift or move the electric machine! Foot injuries could be caused if lifting system or lifting brackets fail.</p>

Security features

The electric machine has at least one PT100 temperature sensor in the windings. The amount of the sensors depends on the options chosen. The temperature signal(s) can be read out from the

Safety information

measurement connector of the electric machine. You can connect the temperature signal to the temperature surveillance pin in the inverter (EC-C) and make sure that the inverter has the machine temperature protection feature activated.

The electric machine can be ordered with bearing temperature measurement. This option includes one PT100 temperature sensor at both D-end and N-end bearings. The signal can be read out using a separate connector at both ends.

The electric machine has leakage sensors (2pcs) at the lower part of the electric machine. This feature is useful in moist conditions to detect possible excessive water in contact with the electric machine. Separate connectors for both leakage signals exist.

Electromagnetic compatibility (EMC)

	<p>When interfacing other equipment, connect only equipment that are specified as part of the system and that are compatible.</p>
	<p>Magnetic and electromagnetic fields generated near the current-carrying conductors and permanent magnets in electric machines represent a health danger to persons with heart pacemakers, metal implants and hearing aids. Persons with a heart pacemaker, metal implants or hearing aids must consult a doctor before they enter the following areas:</p> <ul style="list-style-type: none"> • areas in which electric equipment and parts are operated • areas in which electric equipment with permanent magnets are stored, mounted, operated or repaired <p>If necessary, perform a special electromagnetic compatibility (EMC) test on the installation.</p>

EMC stands for Electromagnetic compatibility. It is the ability of electric equipment to operate without problems within an electromagnetic environment. Likewise, the equipment must not disturb or interfere with any other product or system within its locality. This is a legal requirement for all equipment taken into service within the European Economic Area (EEA).

Our products are designed with high standards of EMC in mind. Connect the power lines and groundings along the instructions in this user guide to achieve the required level of EMI protection.

It is the responsibility of the installer to make sure that the equipment or system into which the product is incorporated complies with the EMC legislation of the country of use. Within the European Union, equipment into which this product is incorporated must comply with the EMC Directive 2014/30/EU.

Product overview



For harsh conditions, like salty air in marine applications, it is recommended to check the surface treatment possibilities with the factory.

The electric machines have been developed especially for heavy duty, marine and transportation applications. They are more reliable, smaller, lighter and more efficient than conventional products on the market.

Typical applications of the electric machines are:

- Motor (electric propulsion) and generator for hybrid marine vessels or mobile work machines and bus parallel hybrid applications.
- Traction motor and generator for electrical or hybrid electrical mobile work machines or buses.

The electric machines feature Synchronous Reluctance assisted Permanent Magnet (SRPM) motor technology, having several advanced features:

- Extremely compact and robust structure.
- High efficiency throughout the operation range.
- Liquid cooling with water-glycol mixture.
- Low coolant flow required.
- High allowed coolant temperature.
- IP65 enclosure class to maximize reliability.
- Multiple mounting possibilities.
- Extended speed and torque capabilities compared to standard PM machines.
- Machine structure designed to be able to produce high starting torques (instant torque to non-moving wheel).
- Optimized speed range to meet most common gear ratios used in heavy mobile machinery.

Product overview

The electric machine

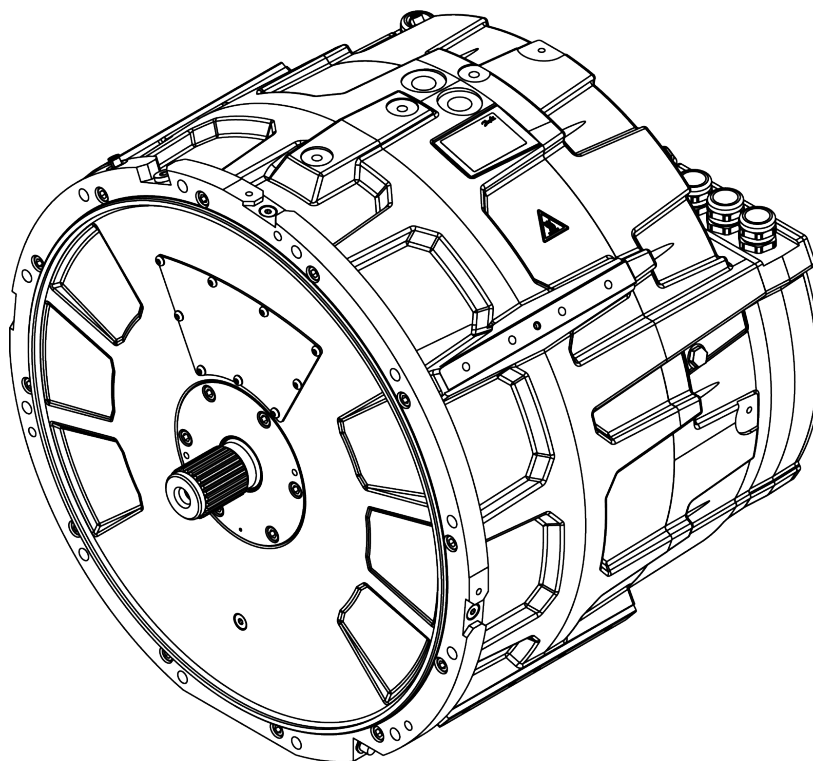

The electric machines have several frame models (sizes) to be the optimal solutions for several applications. They also have options for shaft type, attachment interface, bearings, connection box attachment, rotation sensors and temperature sensors.

Intended use of the electric machine

This electric machine is intended to be used as a motor or generator and as a part of a machinery, for example in:

- Power train of a marine vessel, transportation vehicle or a heavy duty work machine.
- Power generation equipment.

The electric machine is intended to be powered and controlled with an inverter or inverters capable of supplying three-phase alternating current and that is capable of controlling the electric machine. The electric machine is not suitable for direct online use.

In a power generation equipment the electric machines are intended to be powered by a prime mover, for example, an internal combustion engine and controlled by the above mentioned electric power inverter.

The electric machine is solely intended for professional use, and may be operated only by trained professionals. The maintenance of the electric machine may be done only by trained professionals.

Forbidden use of the electric machine

It is forbidden to use, handle and maintain the machine in following ways (including but not limited to):

- Using the electric machine for other purposes than defined in this user guide.
- Disregarding the obligation to comply with the user guide, safety signs and rating plate of the electric machine.
- Using the electric machine, making adjustments and maintenance without first reading this user guide.

Product overview

- Exceeding the designed limits during the electric machine operation.
- Using non-original service parts of wrong material causing corrosion problems and mechanical failures in time.
- Operating and performing maintenance for the electric machine without appropriate personal protective equipment.
- Using electric machine parts like frame, shaft end or terminal box for climbing or for support for other structures.
- Causing any kind of impact forces to the electric machine (for example hitting or hammering or dropping objects).
- Operating the electric machine with electric connections other than defined in the user guide and/or other documents.
- Operating the electric machine with insufficiently tightened connections or cable glands.
- Operating the electric machine with power cables routed against the instructions.
- Operating the electric machine without properly dimensioned and operating cooling system.
- Operating the electric machine without following the bearing lubrication instructions.
- Touching the connection terminal of the electric machine or doing maintenance or adjustment operations on the electric machine with the electricity connected.
- Accessing the connection box(es) if the shaft can be turned by an external prime mover.
- Lifting the electric machine from wrong lifting points and without correct lifting equipment.
- Lifting additional load with the machine.
- Storing the electric machine outdoors in wet or dusty conditions.
- Storing the electric machine without correct support to prevent rolling or falling of the machines.
- Using the electric machine in potentially explosive environment.
- Allowing dirt or liquid to enter into the electric machine or connection box.
- Using cables that cannot withstand the maximum currents of the electric machine.

Used technology

The electric machine is a Synchronous Reluctance assisted Permanent Magnet (SRPM) machine. This technology has several benefits compared to standard permanent magnet (PM) technology and traditional induction machine (IM) technology. The SRPM technology combines the benefits of PM and Synchronous Reluctance technology, having increased torque capability over wide speed range and ability to produce torque to higher speeds. The electric machine efficiency at lower speeds is also good.

The supply current to the machine stator windings create rotating magnetic field, which in turn rotates the rotor containing permanent magnets. In the synchronous permanent magnet machine, the rotation of the rotor (shaft) is synchronized with the frequency of the power supply current. The reluctance technology maximizes the pull-out torque of the machine.

The permanent magnets of the rotor are of salient-pole design, having embedded permanent magnets in the rotor structure. This structure makes the electric machine mechanically more stable and capable of higher speed operations. See Figure below illustrating the magnet topology of the electric machine. The Figure shows the principle only, and is not an exact illustration of the structure.

Product overview

Machine topology

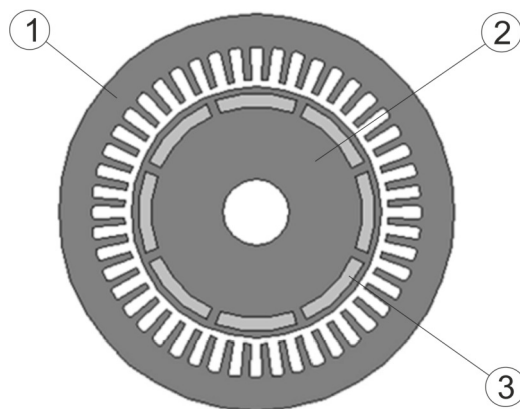

1	Electric machine stator and stator windings
2	Electric machine rotor
3	Permanent magnets in the rotor

System introduction

Danfoss provides electric drive trains for applications in heavy mobile work machines, marine vessels and buses. The drive trains include all essential components for converting from traditional to hybrid electric (HEV) or electric vehicle (EV) solutions. Danfoss technology saves fuel and lowers emission and noise levels.

Overview of the Danfoss drive train system

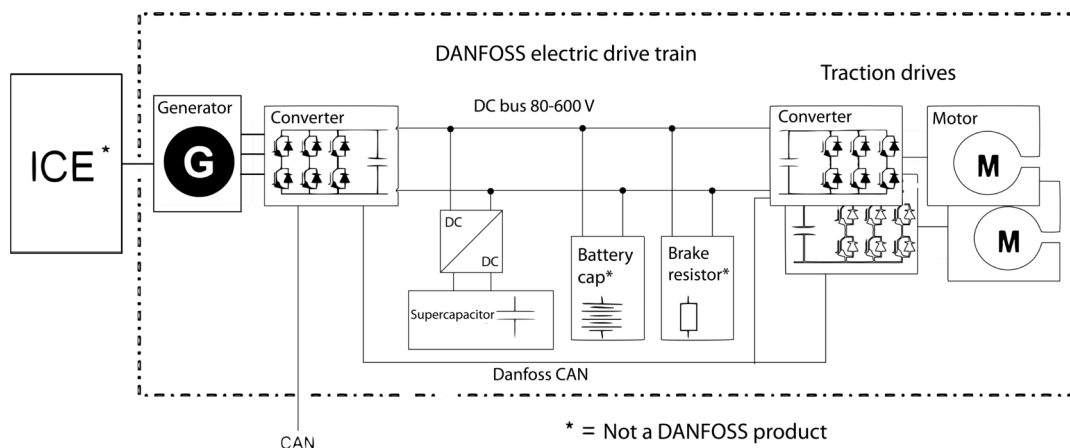

The electric machines are liquid cooled with water-glycol mixture. For more information, see Chapter [Cooling connections](#).

A low voltage measurement signal connector is attached to the electric machines. Different temperature and resolver signals can be read, depending on the machine options chosen. For more information about the connection, see Chapter [Low voltage connections](#).

Product overview

Overview of electric machine system

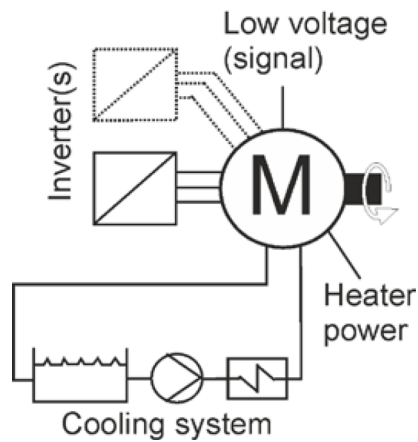

Connections and interfaces

The electric machines are connected mechanically and electrically as a part of a machinery or as a part of a power generation equipment.

Mechanical interfaces:

- Lifting points.
- Flange mounting (D-end).
- Mounting foot rails.
- Shaft connection.
- Cooling system connections (bores).
- Grease escape/fill connections; maintenance use only.
- Air ventilation plug.
- Vibration sensor connection points.

Electrical interfaces:

- Power connections through the connection box.
- Measurement connector (connection through the connection box).
- Anti-condensation heater connection (+HEAT1 option) (through the connection box).
- Bearing temperature connectors (+BTMP1 option).
- Leakage sensor connectors.

Product overview

Connections and interfaces

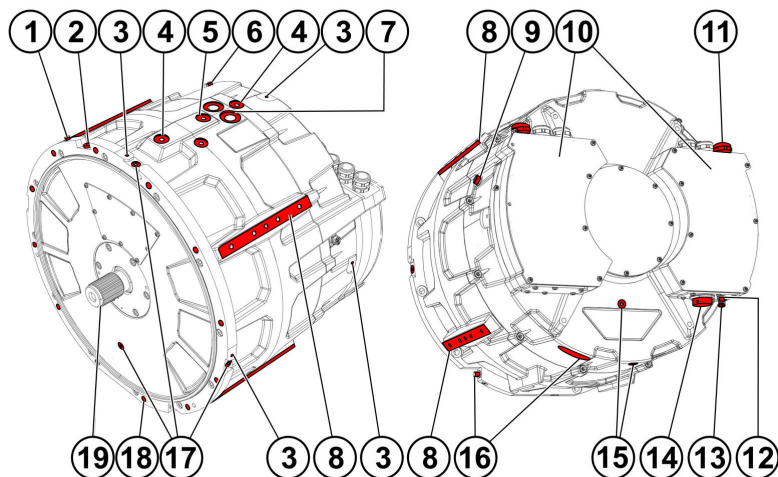

1	Grease fill connection (nipple); D-end.
2	Bearing temperature measurement connector, D-end (+BTMP1 option). Type: 4-pin M12 A coded male.
3	Vibration sensor connection points. Both in the D- and N- end, one on the top and two on the sides.
4	Lifting points. The two outmost needed for normal lifting.
5	Inner lifting point. Can be used for additional lifting lug/eye connection and as machine enclosure (power) grounding connection point when mounted.
6	Grease fill connection (nipple); N-end.
7	Cooling system connections (bores).
8	Mounting foot rails. Four rails in 90° circular pattern around the frame.
9	Air ventilation plug.
10	Connection boxes (two boxes with -DUAL option).
11	Power connection; cable gland (six glands with -DUAL option).
12	Bearing temperature measurement connector, N-end (+BTMP1 option). Connected through the connection box. Type: 4-pin M12 A coded male.
13	Cable gland for anti condensation heater connection cables. Anti connection heater connector inside the connection box.
14	Low voltage connector (measurement connector), low voltage grounding through the connector metal body.
15	Grease escape connections, N-end. One axial and one radial plug (downwards) in the N-end.
16	Leakage measurement connectors. One leakage measurement connector in both ends.
17	Grease escape connections, D-end. One axial plug and four radial plugs in 90° angles around the flange in the D-end.
18	D-end flange mounting (12 connection bores around the flange).
19	Shaft connection.

Product overview

Rating plate

Each electric machine has a rating plate which can be found on the machine frame. The rating plate contains machine rating and identification. The rating values in the Figure below are not correct for this machine. See the rating plate on the machine and data sheets for the correct values.

Rating plate

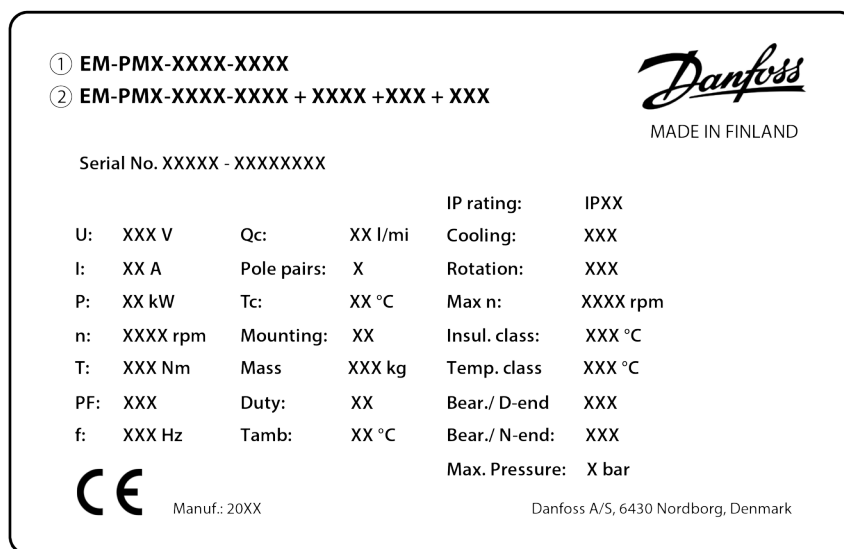

Rating plate fields

Field	Explanation	Unit
1	Electric machine product family: EM-PMI or EM-PME	
2	Electric machine type code and options	
Serial No.	Serial number	
U	Rated voltage (phase-to-phase AC)	V _{rms}
I	Rated current (AC)	I _{rms}
P	Rated power (S9) according to IEC60034-1	kW
n	Rated speed	rpm
T	Rated torque (S9) at rated speed	Nm
PF	Power factor	
f	Rated supply frequency at nominal speed	Hz
Q _c	Rated coolant liquid flow	l/min
Pole pairs	Number of magnetic pole pairs of the machine	
T _c	Rated coolant liquid input temperature	°C
Mounting	Allowed mounting position according to IEC60034-7	
Mass	Mass of the electric machine	kg
Duty	Defined rotating electric machine duty cycles by IEC60034-1 standard	
T _{amb}	Rated ambient temperature	°C
IP rating	Enclosure class according to IEC60034-5	
Cooling	Cooling method according to IEC60034-6	
Rotation	Direction of rotor rotation with default phase order. Observed facing the D-end.	

Product overview

Rating plate fields (continued)

Max n	Maximum rotation speed	rpm
Insul. class	Temperature rating (class) of insulation of the electric machine according to IEC60034-1	
Temp. class	Temperature rating (class) of individual insulation materials of the insulation according to IEC60034-1	
Bear. / D-end	Bearing type (types) in the D-end of the electric machine	
Bear. / N-end	Bearing type in the N-end of the electric machine	
Max. pressure	Cooling liquid max pressure	
CE	CE marking	

Tightening torques

	Tightening torque tolerance is +/- 5% of the specified tightening torque, unless otherwise stated.
	Use threadlocking adhesive for RST, that is, stainless steel bolts to avoid breakage.
	Do not install dry screws or other fastening equipment. Add suitable lubrication, for example Wuerth HSP 1400, to prevent excess friction.

Connection	Tightening torque
Mounting bolts for D-end attachment, M12 min. grade 8.8, DIN 912	80 Nm
Connection box mounting screws	7 Nm
Connection box cover plate screws	4 Nm
Cable lug	15 Nm
Additional attachment points (M10 grade 8.8.)	47 Nm

Tightening torques to use unless otherwise noted

	8.8	10.9	12.9
Thread	Nm	Nm	Nm
M5	7	10	11
M6	11	17	19
M8	27	40	47
M10	54	79	93
M12	93	137	160
M14	148	218	255
M16	230	338	395

Design principles

This Chapter describes design principles that must be taken into account when designing the system using the electric machine.

System design

Cooling and temperature measurement

	<p>Do not operate the electric machine without correctly dimensioned and operating cooling system.</p>
	<p>Mount the electric machine in correct position, see Chapter Allowed mounting position.</p>
	<p>When you connect the cooling system make sure that the cooling medium flows freely in and out from the electric machine with the cooling medium flow equal or higher than rated.</p>
	<p>The cooling medium temperature at the inlet of the electric machine must be lower or equal to the rated temperature.</p>

See more detailed information about coolant connection bore specifications, required coolant liquid flow and other specifications in the product data sheet. Rated values can be found from the electric machine rating plate.

The electric machine has at least one PT100 temperature sensor in the windings. The amount of the sensors depend on the options chosen. The temperature signal(s) can be read out from the measurement connector of the machine.

You can connect one temperature signal to the temperature surveillance pin in the inverter (EC-C1200) and make sure that the inverter has the machine temperature protection feature activated.

The maximum allowed winding temperature of the electric machine is shown in the rating plate and in the data sheet.

The PT100 temperature sensor characteristics are: resistance 100 Ω at 0°C temperature, and the resistance increases 0.385 Ω per each 1°C increase of temperature.

Insulation lifetime

	<p>Heat cycles, environment, moisture, vibrations and similar variables have an effect on the lifetime expectancy of the insulation of the electric machine. The value of the insulation lifetime expectancy is a calculated value and it is not tested in practice.</p>
--	---

The insulation of the electric machine has the following lifetime expectancy.

Design principles

Insulation class	Lifetime expectancy
F (150°C)	20 000 h
H (175°C)	20 000 h 100 000 h if driven with maximum winding temperature of 150°C

Inverter

The electric machine is intended to be powered and controlled with an inverter capable of supplying three-phase alternating current and that is capable of controlling the electric machine. The electric machine is not suitable for direct online use.

If the electric machine is driven with an inverter from a supplier other than Danfoss Editron, the electric machine performance may differ from rated values. The optimum performance of the electric machine is obtained with Danfoss Editron inverters. These inverters are:

- Compact and light.
- Liquid cooled.
- Tolerant to high mechanical vibration (10 G) and shock (50 G).
- Efficient, efficiency > 98 %.
- Reliable, no moving components.



Do not exceed the maximum rotation speed of the electric machine.

EC-C1200



Design principles

Schematic of the inverter powerstage

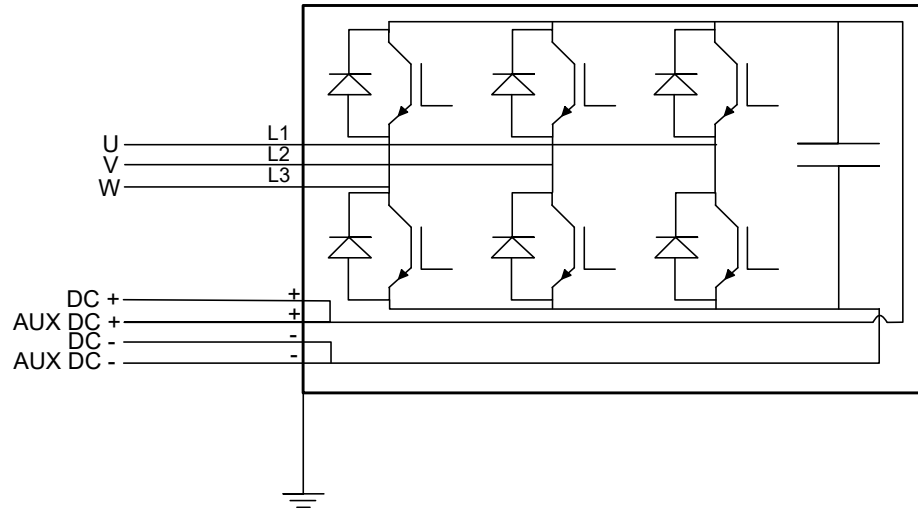

The main machine power driving parameters are shown in the machine rating plate. For more information, contact Danfoss representative.

You can connect one of the temperature signals (from the low voltage connector) to the temperature surveillance pin in the inverter and make sure that the inverter has the machine temperature protection feature activated.

Mounting structure

Supporting structure requirements



Do not install the electric machine near or in direct contact with easily flammable materials. The surface of the electric machine can be hot.

The mating housing arrangement of the electric machine must be secure and sufficiently rigid to prevent vibrations and mechanical failures. Necessary actions should be taken to avoid corrosion on the mating housing arrangement.

The supporting structure for the electric machine must be such that the electric machine can be mounted using its allowed mounting positions, see Chapter [Allowed mounting positions](#).

The mounting space must be adequate for the electric machine mounting and possible auxiliary components. See the length and the diameter data of the electric machine from the product drawing. Main dimensions of the electric machine are shown in the Figure below (the illustration may differ from the actual electric machine).

The electric machine has a SAE 1/2 D-end flange (IM 3001). A SAE 1/2 flywheel housing is required as mating flange. The connection boxes are connected to N-end.

Design principles

Main dimensions of the electric machine

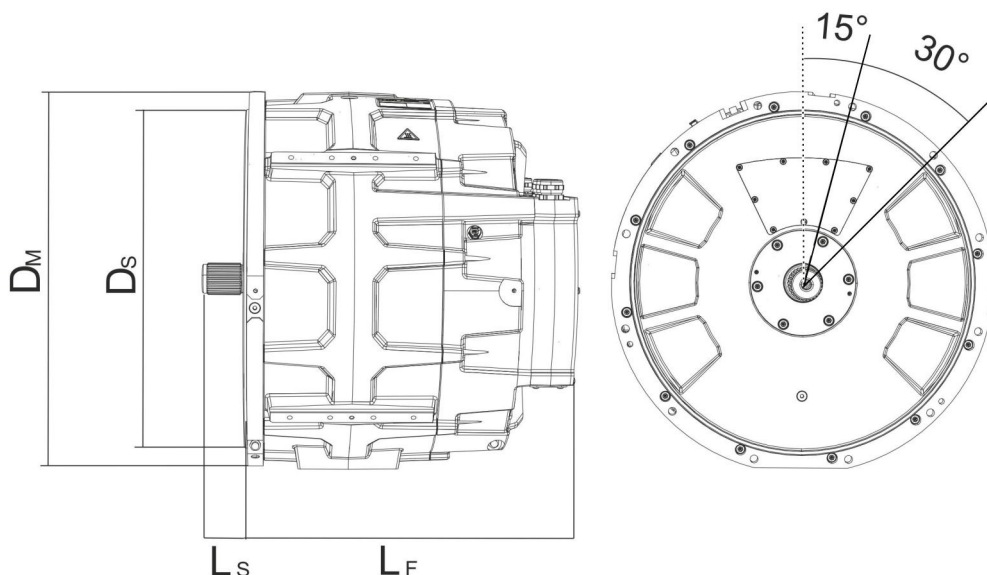

Symbol	Explanation
L_F	Length of the electric machine frame (including the connection box(es)).
L_S	Length of the shaft (from the end of the shaft to the electric machine D-end mounting shoulder).
D_M	Diameter of the flange mounting bore circle.
D_S	Diameter of the mounting shoulder.

For all dimensions of the electric machine, see the product drawings.

Shaft alignment and load

	<p>Improper alignment (misalignment) may result in bearing overloads, premature bearing failures, vibrations and shaft failures. Use of flexible coupling is recommended. Flexible coupling does not compensate for excessive misalignment, so proper alignment must be ensured regardless of the coupling type used.</p>
--	--

The type of the electric machine shaft is DIN 5480 W55x2x26x8a. The flange type is SAE 1/2 Transmission housing.

Alignment between the shaft and mating structure must be accurate. Flexible coupling does not compensate for excessive misalignment.

The misalignment can be parallel or angular misalignment, or combination of those. With parallel misalignment, the center lines of both shafts are parallel but they are offset. With angular misalignment, the shafts are at an angle to each other. Figures below illustrate the parallel and angular misalignment.

Design principles

Parallel alignment of the shaft and mating structure

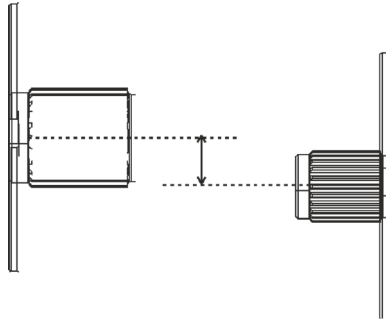

Maximum parallel misalignment values

	Non-flexible coupling *	Flexible coupling *
rpm	mm	mm
0-1000	0.07	0.13
1000-2000	0.05	0.10
2000-3000	0.03	0.07
3000-4000	0.02	0.05
4000-6000	< 0.02	0.03

* The values given might differ between coupling types.

Angular alignment of the shaft and mating structure

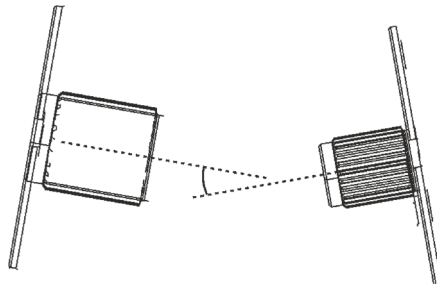

Maximum angular misalignment values

	Non-flexible coupling *	Flexible coupling *
rpm	mm / 100 mm	mm / 100 mm
0-1000	0.06	0.10
1000-2000	0.05	0.08
2000-3000	0.04	0.07
3000-4000	0.03	0.06
4000-6000	< 0.03	0.05

* The values given might differ between coupling types.



The maximum external force directed to the shaft axially and radially may not exceed machine specific values. For more information, see document DOC-000454. Calculate the relevant values with the help of the document. Contact Danfoss service at <https://danfosseditron.zendesk.com/hc/en-gb> or send email to editron.service@danfoss.com to obtain the document.

Design principles

External shaft forces of the electric machine

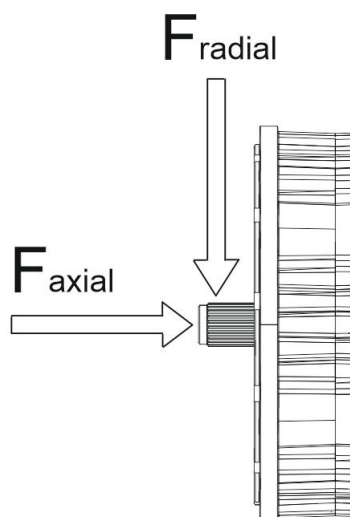

Transportation and storage

Transportation

	<p>Heavy equipment. Handle with care during transportation.</p>
--	--

Electric machine is shipped in first class condition. It has been inspected and packed correctly to prevent damage from ordinary handling during shipment. During transportation, shocks, falls and humidity should be avoided. Protect the cooling holes for transportation.

The weight of the electric machine can be found on the machine rating plate, and in the product data sheet.

Receiving and unpacking

	<p>Do not touch the electric machine during the insulation resistance check. Discharge the electric machine afterwards.</p>
	<p>Do not touch the electrical terminals when the rotor is rotated. The electrical terminals have dangerous voltage during rotation. Contact Danfoss representative if the rotor can not be rotated.</p>
	<p>Remove the transportation supports of the electric machine.</p>







Check upon arrival and unpacking

- The electric machine and the package must be inspected immediately upon arrival. Make sure that the rating plate data in the cover letter complies with the purchase order. Any external damage (in shaft-ends, flanges, electrical interfaces and paint) must be photographed and reported immediately.
- It is recommended to measure the insulation resistance of the electric machine upon arrival, or before installing the electric machine. Reference value of 150 MΩ shall be exceeded in room temperature, otherwise contact Danfoss representative. Refer to Chapter [Insulation resistance test](#) on page 31.
- Remove any shaft locks and rotate the shaft. It is normal for the rotation of the shaft to be difficult.

Lifting

	<p>Use correct, adequately dimensioned lifting devices and inspect them before lifting.</p>
	<p>Do not lift from the shaft of the electric machine!</p>

Transportation and storage

	Do not apply any excess weight on the electric machine when lifting.
	Use correct lifting slings. Use correct position and angle of lifting.
	See the electric machine rating plate for weight information.
	Lift the electric machine using the correct lifting lugs/eyes only.
	Do not go under a lifted load.
	Lifting slings cannot touch the electric machine during the lifting.

Transportation and storage

Lifting lugs/eyes/points for lifting slings and lifting position of the electric machine

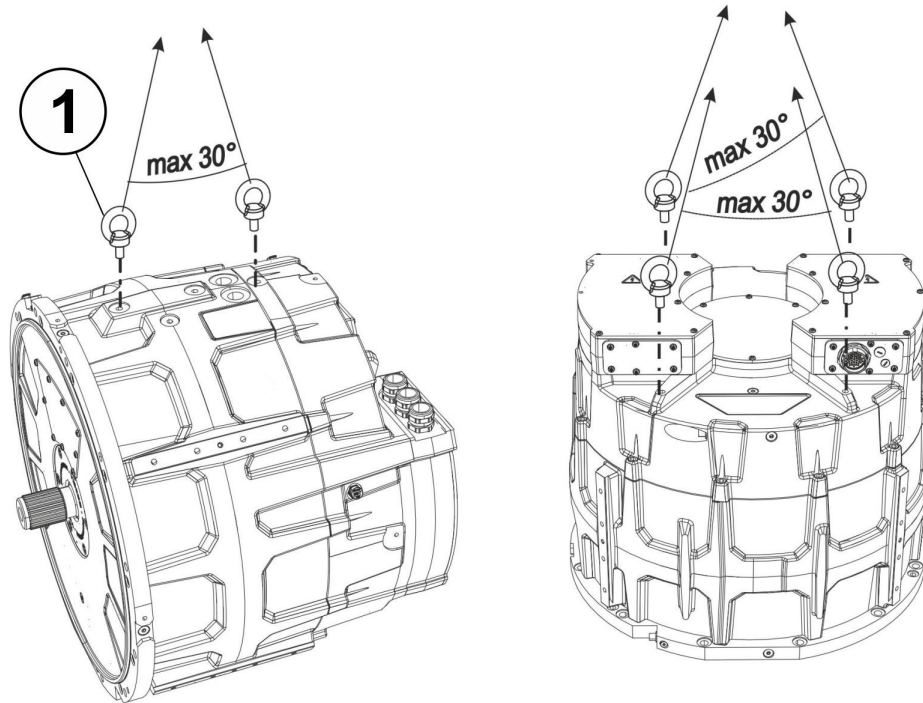

1	Lifting eye type of ANSI B18.15.1M M12x19 is recommended in M12 bores for horizontal and vertical lifting. Not included in the delivery. Use the outmost lifting positions in horizontal lifting.
---	---

Horizontal lifting

Install 2 pieces of lifting eyes to the lifting bores in the electric machine frame. The lifting eyes should be mounted with their full threaded length.

Vertical lifting

Install 4 pieces of lifting eyes to the lifting bores in the N-end bearing shield (non-shaft end). Lifting eye should be mounted with its full threaded length.

Storage

	Do not touch the electrical terminals when the shaft is rotated. The electrical terminals have dangerous voltage during rotation.
	Keep the electric machine on a correct base. Support the electric machine to prevent accidental turning and falling.

Transportation and storage

- Always store the electric machine indoors. Storage temperature must be above -20°C and relative humidity less than 60 %.
- The storage should be dry, dust free and vibration free.
- Treat the unprotected electric machine surfaces such as the shaft-end and flanges against corrosion. Seal the cable exit holes and cooling bores for storage.
- The electric machine must not be subject to any external vibrations during storage to avoid damage to the bearings.
- To avoid water condensing in the electric machine, use anti-condensation heater(s), if fitted, or direct winding heating to keep the machine temperature above dew point.
- Rotate the shaft of the electric machine by hand monthly at least ten revolutions to prevent grease migration. If necessary use a tool such as a spanner. Do not damage the shaft in any case.

Extended storage

Electric machines equipped with relubricable bearings: apply grease before and after long term storage.





It is recommended to inspect the electric machine in storage at periodic intervals. Use attached storage checklist.

Rotate the shaft of the electric machine once a month.

Keep the electric machine in its installation position while in storage. For example, vertically installed electric machines should be stored in vertical position.

Installation

The following safety and information related symbols appear in this user guide and on the electric machine.

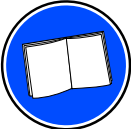
	<p>Risk of electric shock when the connection box is open. When you work with power connections make sure that electricity is disconnected and rotor rotation is prevented.</p>
	<p>Magnetic and electromagnetic fields generated near the current-carrying conductors and permanent magnets in electric machines represent a health danger to persons with heart pacemakers, metal implants and hearing aids. Persons with a heart pacemaker, metal implants or hearing aids must consult a doctor before they enter the following areas:</p> <ul style="list-style-type: none"> • Areas in which electric equipment and parts are operated. • Areas in which electric equipment with permanent magnets are stored, mounted, operated or repaired.
	<p>Risk of electric shock when working with the electric machine. Use isolated electric tools.</p>
	<p>Only trained and qualified personnel familiar with the relevant safety requirements can work with the electric machine.</p>
	<p>Use correct personal protective equipment when you are near the electric machine.</p>
	<p>Read the instructions in this user guide before you install the electric machine.</p>

Installation

Required tools

Following tools are required to install the electric machine:

- Grease pump.
- Ratchet torque wrench.
- Hex head wrench kit with different metric sizes.
- Socket wrench kit with different metric sizes.
- Cable gland tightening tool. Size according to cable glands.
- Cable skinning knife.
- Crimping tool for cable lugs. Consult cable lug manufacturer for correct size and crimping.
- Lifting slings with sufficient rated capacity.
- Lifting eyes. Size according to machine type. See Chapter [Lifting](#) on page 26.

Insulation resistance test

	Before performing the insulation resistance measurement, disconnect all cables and connectors from the electric machine under test.
	Do not touch the electric machine during the insulation resistance check. Discharge the electric machine afterwards.
	Measure the insulation resistance of the electric machine before and after the installation of the electric machine.

Measure the insulation resistance of the electric machine before and after the installation of the electric machine. Because of the structure of the electric machine, it is possible that the stator is damaged during the installation.

Reference value of 150 MΩ has to be exceeded at reference ambient temperature 25°C (measured with 500 V_{DC} / 1 min insulation resistance test). Contact Danfoss Editron service if the reference value is not exceeded.

Measuring the insulation resistance

	Insulation resistance testers generate lethal voltages. Only qualified personnel should perform insulation resistance measurements.
--	--

The insulation resistance is measured between motor terminals and the frame. When measuring the windings, the auxiliary circuits and other windings are grounded. When measuring the auxiliary circuits, all windings are grounded.

Dual winding motors - Winding 1

Test voltage	Test duration	Pass criteria
500 V _{DC}	60 s	> 150 MΩ

Measurement procedure:

Installation

1. Connect winding 2 phases to the motor frame.
2. Connect all pins of the LV connector, bearing temperature sensors and heaters to the motor frame.
3. Connect the measurement devices ground cable to the motor frame.
4. Connect the measurement probe to the winding 1 phases.

Dual winding motors - Winding 2

Test voltage	Test duration	Pass criteria
500 V _{DC}	60 s	> 150 M Ω

Measurement procedure:

1. Connect winding 1 phases to the motor frame.
2. Connect all pins of the LV connector, bearing temperature sensors and heaters to the motor frame.
3. Connect the measurement devices ground cable to the motor frame.
4. Connect the measurement probe to the winding 2 phases.

Installation

Dual winding motors

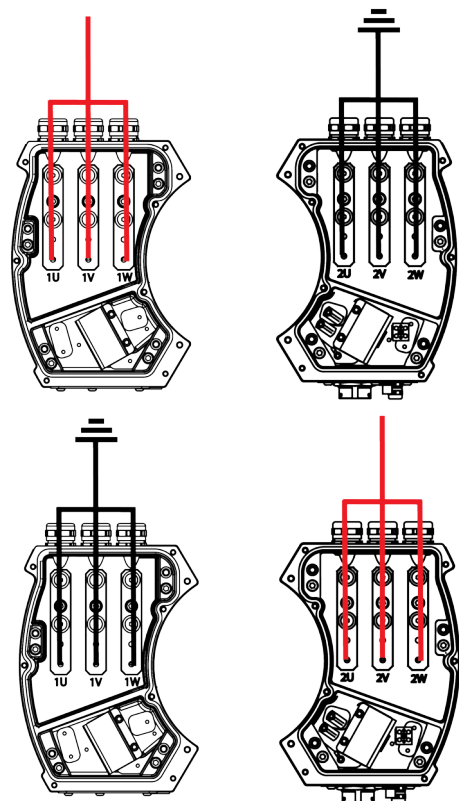
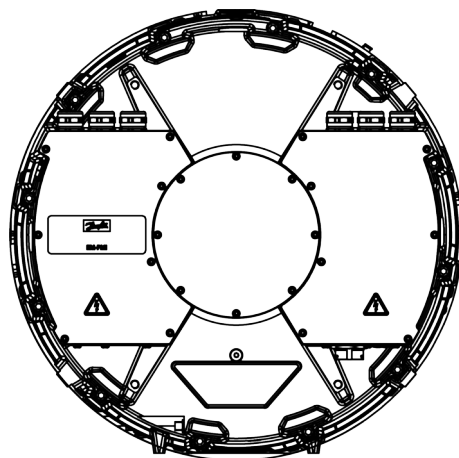

Mechanical installation

Allowed mounting positions



If the application is a moving work machine or similar, it is allowed to deviate from the allowed mounting position for the duration of 30% of the work cycle. This applies to electric machines with grease lubricated bearings.

Installation



It is in some cases possible to make an exception from the limitations of the mounting positions. Document *Allowed bearing loads for EM-PMI machines DOC-000454* gives more information about this. Contact Danfoss to obtain the document.

The electric machine can be installed horizontally or vertically. See Figures below for the allowed installation angles in each case.

Nominal allowed horizontal mounting position of the electric machine

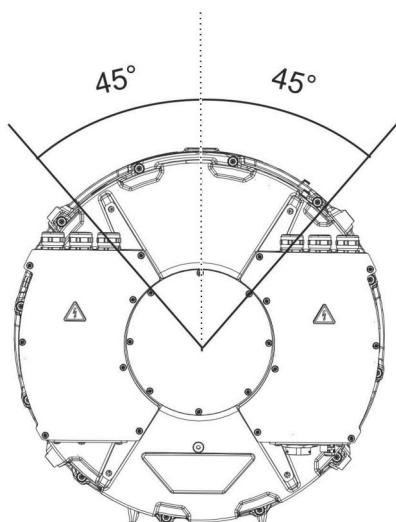

Line type	Meaning
	Allowed machine tilt angle for continuous operation. (viewed from the shaft end)
	Allowed momentary machine tilt angle, for the maximum duration of 30 % of the work cycle. (viewed from the shaft end)

Allowed machine tilt angle during operation

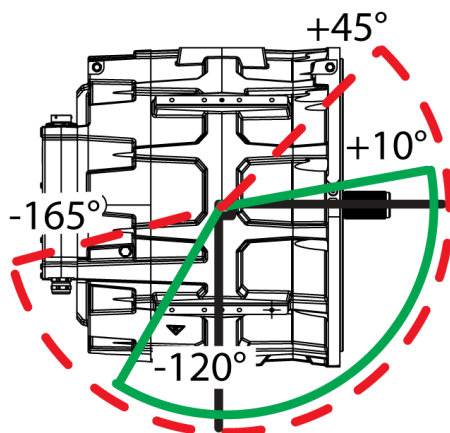

Installation

Mounting the electric machine

	<p>Do not exceed the maximum axial and radial forces calculated for the shaft. Document Allowed bearing loads for EM-PMI machines DOC-000454 gives more information about this. Contact Danfoss to obtain the document.</p>
	<p>Do not use the N-end of the electric machine for mounting the electric machine.</p>
	<p>Use the mounting foot rails only for additional support if needed.</p>
	<p>Refer to Chapter Allowed mounting positions for the correct mounting positions of the electric machine.</p>

Mount the electric machine on a correct supporting structure as discussed in Chapter [Supporting structure requirements](#).

Horizontal assembly

1. Lift the electric machine to the correct mounting position. See Chapter [Lifting](#) for details.
2. The electric machine is mounted from its D-end flange (SAE1/2 transmission housing flange). SAE1/2 flywheel housing is required as a mating flange. If additional support is needed, use the mounting foot rails on the side of the electric machine (4 pieces). For these mounting rails, use bolts of minimum strength M10 8.8. and minimum 20 mm thread engagement.
3. Align the electric machine with the mating housing alignment. See Chapter [Shaft alignment and load](#).
4. Connect the shaft of the electric machine. Make sure to use full spline engagement. Lubricate the spline.

	<p>Before connecting to the shaft of the electric machine, clean the protection wax on the shaft splines carefully to avoid potential reaction with the spline lubricant.</p>
	<p>A recommended spline lubricant is a 50/50 compound of a high temperature grease and a molybdenum disulphide powder. When applied initially and re-applied at proper intervals, it will help prevent fretting corrosion and premature wear. This lubricant is not soluble in oil and should be used accordingly. Further products which may be recommended are Molycote, Metaflux, Never Seeze, Optimol and similar.</p>

5. Attach the mounting bolts. For steel housing the minimum length of the bolt is 40 mm and for aluminum housing 45 mm. Refer to Chapter [Tightening torques](#) on page 19 for the correct tightening torques.

	<p>Use tightening torque of 69 Nm for D-end bolts. The N-end of the electric machine is not intended to be used for mounting.</p>
--	--

Installation

Mechanical mounting connections of the electric machine (horizontal mounting)

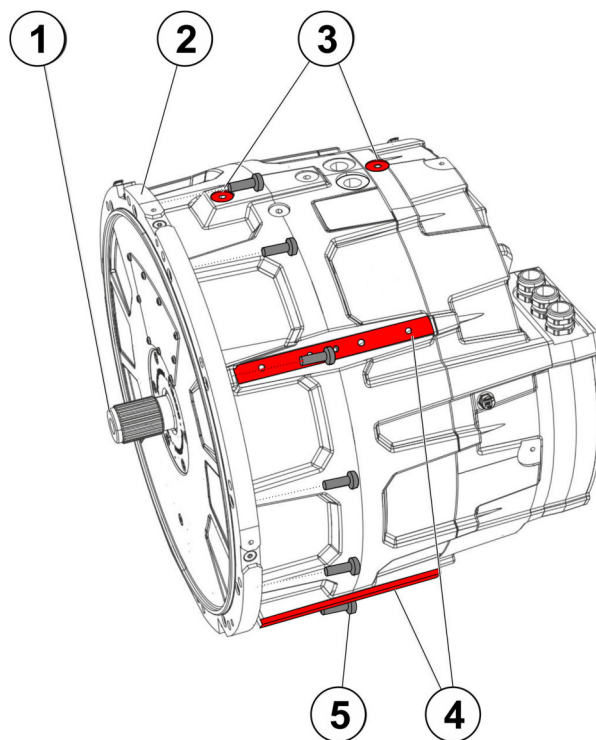

1	Shaft of the electric machine; spline structure of the shaft (DIN 5480 W55x2x30x26x8a).
2	D-end flange (SAE1/2) and bolt bores for mounting the electric machine (12 pieces).
3	Bores for the lifting eyes.
4	Mounting foot rails (see <i>Main dimension drawing</i>).
5	Mounting bolts (12 pcs of DIN 912 M12 socket head). Not included in the delivery.

Vertical assembly

In vertical assembly, follow the Steps given in the previous Section *Horizontal assembly*.

Installation

Mechanical mounting connections of the electric machine (vertical mounting)

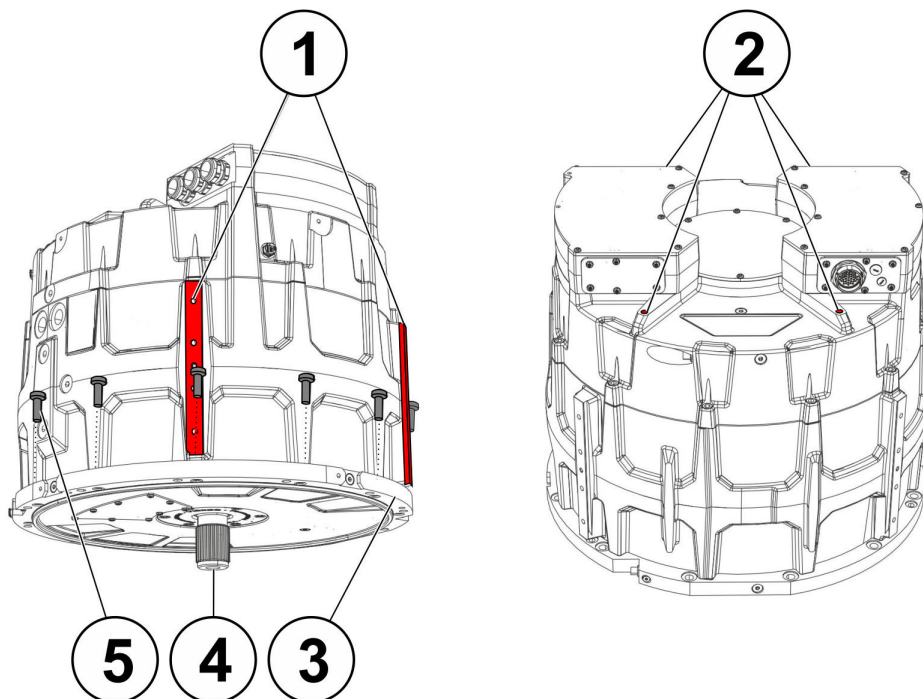

1	Mounting foot rails (4 rails in 90° circular pattern around the frame).
2	Bores for the lifting eyes, N-end.
3	D-end flange (SAE1/2) and bolt bores for mounting the machine (12 pieces).
4	Shaft of the electric machine; spline structure of the shaft (DIN 5480 W55x2x30x26x8a).
5	Mounting bolts (12 pcs of DIN 912 M12 socket head). Not included in the delivery.

Foot mounting option

The electric machine can be equipped with foot mounting option (+FM1). For the installation of the electric machine, use 8 pieces of mounting bolts (M16 EN-ISO 4014 / 4017 M16 10.9 bolts and washers) that are tightened to 280 Nm. See the Figure below.

Installation

Foot mounting, optional

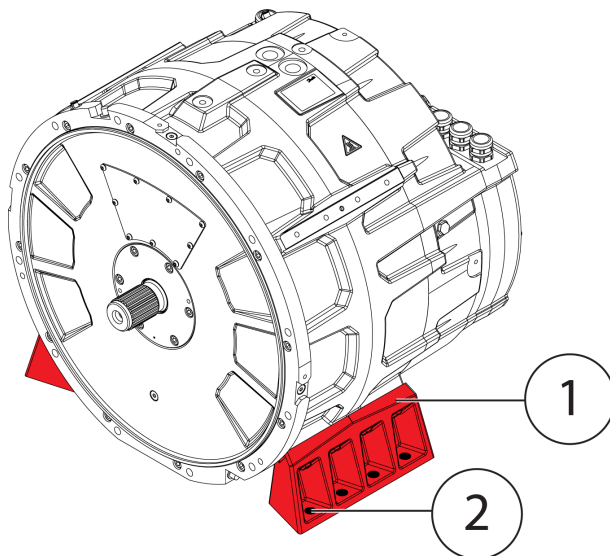

1	Foot mounting
2	Foot mounting attachment holes

Cooling connections

	Make sure that cooling liquid runs freely into and out from the electric machine.
	To prevent damage to the cooling connectors, refer to the documentation of the manufacturer for the correct tightening torque of the cooling liquid nipples.
	When selecting cooling liquid nipples, choose nipples that can resist galvanic corrosion.

Connect the electric machine properly to the cooling circuit. Make sure that the coolant flow is equal or higher than rated and the coolant temperature at the inlet of the machine cooling is lower or equal to the rated temperature. For more information, see Chapter [Recommended coolants](#) and product data sheet. Rated values can be found in the electric machine rating plate.

Aluminum frame water-cooled construction is only to be used with a closed fresh water circulation with corrosive inhibitor described in the data sheet. The water cooling circuit connection is described in the data sheet. Use only suitable and high-class connection parts and seals to connect the electric machine to the water circuit. Check for possible leaks after the piping and joints have been connected.

It is recommended to use coolant connector equipped with o-ring seal or to use sealing washer (for example Usit or Bonded seals) in the connection. In addition, it is recommended to use thread sealant (Loctite 577 or similar) at the coolant connections to prevent loosening. Loosening can be caused by vibration or temperature variations.

Installation





The electric machines are equipped with at least three PT100 temperature sensors in the windings. The amount of the sensors depend on the options chosen. The temperature signal(s) can be read out from the measurement connector of the machine.

You can connect the temperature signal to the temperature monitoring pin in the inverter (EC-C) and make sure that the inverter has the electric machine temperature protection feature activated.

Electrical installation

Power connections

High voltage connection

	<p>Risk of electric shock when connection box is open. When you work with power connections make sure that electricity is disconnected and shaft rotation is prevented.</p>
	<p>When installing the connection box lid, make sure there are no foreign particles between the connection box lid and the insulation and that all connection box fasteners are in place. Missing or loose screws can compromise the insulation.</p>
	<p>Make sure the power cables exit straight from the terminals and do not rub against the sharp cable through-holes or other sharp edges which could wear out the cable insulation over time.</p>
	<p>Do not place any excess weight on the connection box lid(s).</p>

The high voltage cables of the electric machine are connected to the connection box(es) of the electric machine. The figure below shows the components of the high voltage connection box assembly.

You are allowed to open only the nuts and bolts that are specified here. Only Danfoss professionals are allowed to open other nuts and bolts in the terminal box.

Installing the power cables:

1. Remove the cover of the terminal box.
2. Install the power cables.
 - a. Remove the cable lug attachment nut/bolt and washers.
 - b. Place the cable lug against the busbar.
 - c. Place flat washer on top of the cable lug and spring washer on top of the flat washer.
 - d. Screw on the nut/bolt and tighten. Refer to Section [Tightening torques](#) on page 19 for the correct torque.
3. Install the cover of the terminal box back.

For more information on how to install the power cables, see especially Steps 8-13 in [Cable gland assembly and power line connection](#) on page 42.

Installation

High voltage connection assembly structure

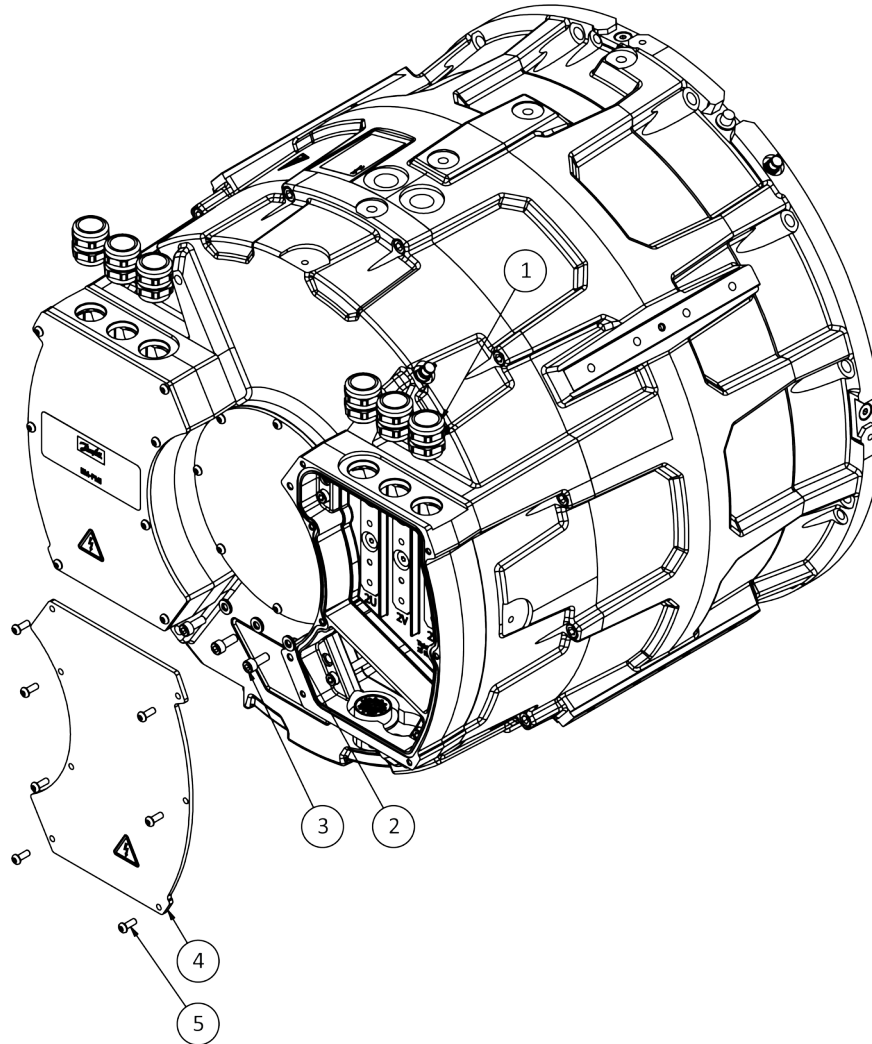

Part number	Qty	Description	Type
1	6	Cable gland	M32 x 1.5, BG 232MSTRI Pflitsch
2	12	Spring disc	D8, DIN 2093, 8.2 x 16 x 0.9
3	14	Bolt, socket head	M8 x 20 DIN 912 (ISO 4762) zinked
4	1+1	Plate	T=5
5	31	Bolt, socket head	M6 x 16, ISO 7380, A4

The Figure below illustrates the connection box from the inside. The power connections are located in the upper part of the connection box. The lower part incorporates the low voltage signal cabling (winding temperature, bearing temperature and resolver) from the low voltage connectors as well as the anti-condensation heater connector. For further information, see Chapters [Low voltage connections](#) on page 48 and [Anti-condensation heater connections](#) on page 55.

Installation

Inside view of the machine connection box and connection points for HV cable lugs

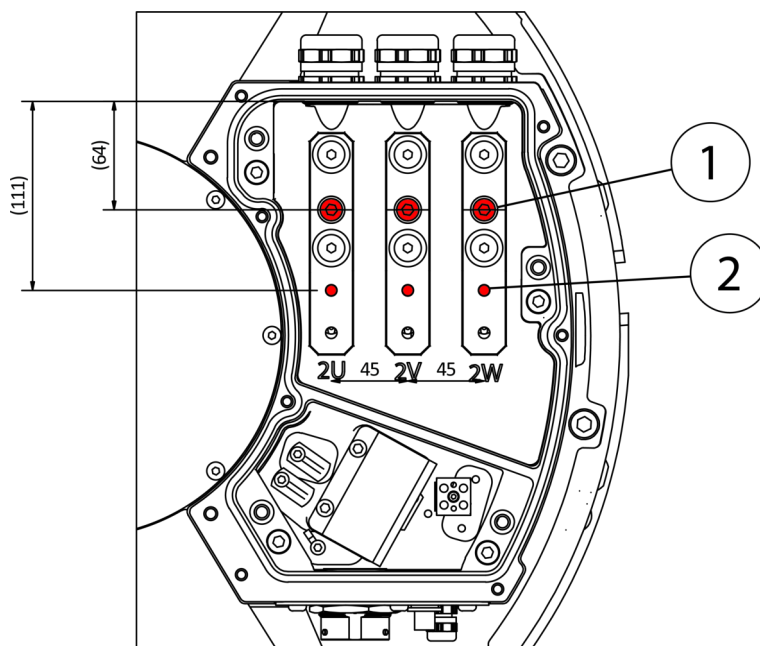

1	M8 bolts for cable lugs
2	Alternative position for cable lugs

The connection box(es) of the electric machine are in fixed position and cannot be rotated or changed with each other.

Leave the connection box cover plate open for further electrical assembly as instructed in Chapter [Cable gland assembly and power line connection](#) on page 42.

Connection diagram

The electric machines are intended to be powered and controlled by three-phase alternating current, supplied by an inverter or inverters. The electric machine is not suitable for direct online use.

The amount of inverters depends on the electric machine and converter current ratings. See also the relevant wiring diagrams.

For an electric machine with option DUAL (two connection boxes each containing one three-phase system), the electrical connection principles from the inverters are shown in the Figure below.

Installation

Connection diagram for DUAL option

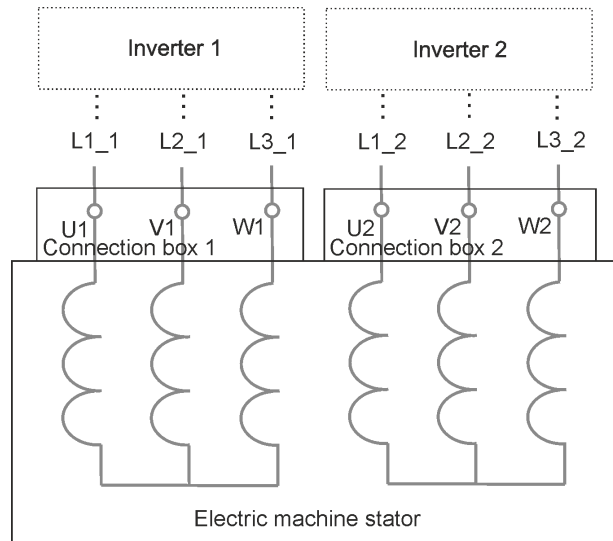

Cable gland assembly and power line connection

	<p>If you are not using the recommended cable lugs, select cable lugs that leave 10 mm gap between each and every cable lug on the same connection plate.</p>
	<p>The pictures are schematic, and the actual components can look different.</p>

This Chapter describes how to assemble screened power cables to the electric machine. See the cable glands recommendations from the Table below. Cable gland assembly instruction can also be found from PFLITSCH gland catalog available from <http://www.pflitsch.de>.

Use correct type of gland for different cable diameters. These are shown in the Table below.

Cable gland alternatives

Cable gland	Cable cross sectional area (*)	Thread	Max. cable Ø	Max. shield Ø
Pflitsch bg 225ms tri	35 mm ² 50 mm ² 70 mm ²	M25 x 1.5, 7.5 mm	20 mm	16 mm
Pflitsch bg 232ms tri	70 mm ² 95 mm ² 120 mm ²	M32 x 1.5, 8.0 mm	25 mm	20 mm

(* Applicable with the recommended cable type (HUBER+SUHNER Radox Elastomer S)

Blueglobe cable gland tightening torques

Metric thread	Nominal torque
M10 x 1.0	3.0 Nm
M12 x 1.5	5.0 Nm
M16 x 1.5	8.0 Nm

Installation

Blueglobe cable gland tightening torques (continued)

Metric thread	Nominal torque
M20 x 1.5	10.0 Nm
M25 x 1.5	15.0 Nm
M32 x 1.5	15.0 Nm
M40 x 1.5	20.0 Nm
M50 x 1.5	30.0 Nm
M63 x 1.5	35.0 Nm
M75 x 1.5	80.0 Nm
M85 x 2.0	100.0 Nm

1. Remove the small hexagonal piece from the BlueGlobe-sealing insert as shown in Figure below.

BlueGlobe-sealing

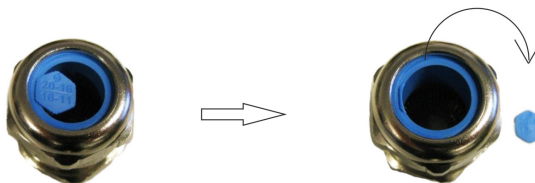

2. Cut the cable sheath at the distance A from the end of the cable, see Figure below. Pull the cut part of the sheath partly (length B is from 10 to 15 mm) off the cable as shown in the Figure. The distance A depends of the length of the cable lug used. Measure with the cable lug that is used and cut to suitable length.

	<p>Do not remove the cable sheath completely at this point and do not cut the braid screen of the cable!</p>
--	---

Cut length of the cable sheath

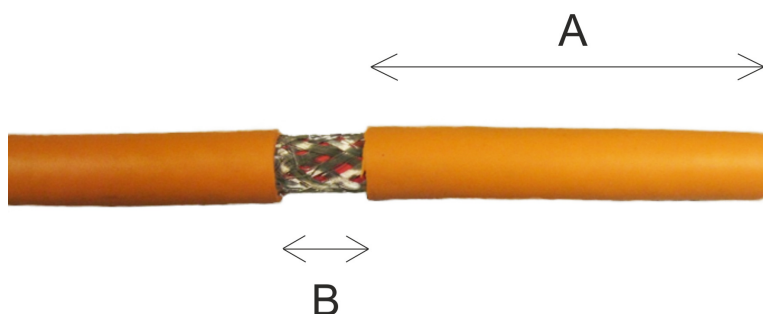

3. Wrap two layers of copper tape on the cable so that the distance B is covered. Use 3M™ Copper Foil Tape 1181 or similar. Contrary to the image below and depending on the cable and the cable gland size, you can leave the length A sheath in place for the next step to help the placement of the cable gland and remove the sheath only after the next step.

Installation

Cover the cable with copper tape

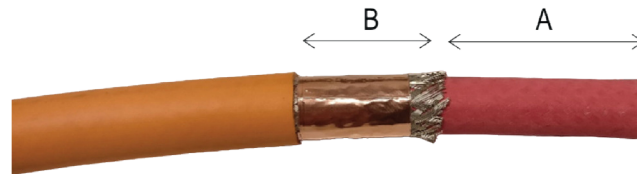

4. Insert the cable to the cable gland with slight turning motion. This helps the cable to go through the spring inside the cable gland. Push the cable gland against the sheath of the cable as shown in Figure below.

Cable to the gland assembly



5. After the cable gland is in place remove the length A piece of the sheath and cut the braid screen (cover) from 10 mm (distance C) from the gland bottom as shown in Figure below.

	<p>Make sure that the cable gland spring is against the cable sheath (that is protected with copper tape) before cutting the braid screen.</p>
--	---

Installation

Cut the braid screen

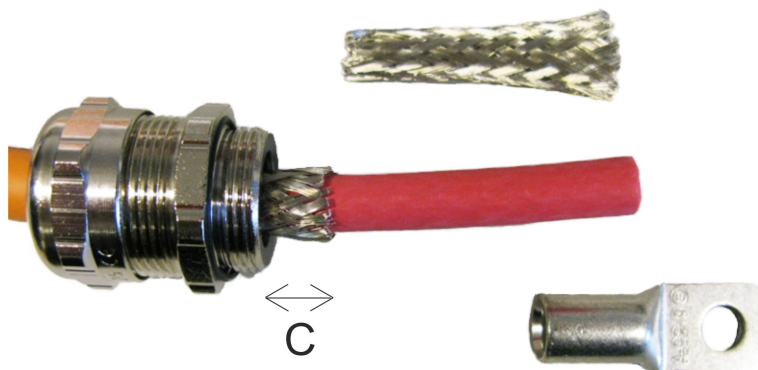

6. Cut a piece of length D of the inner sheath shown below in the Figure *Cutting the inner sheath*. The length D must equal to the length of the cable lug body.

Cutting the inner sheath

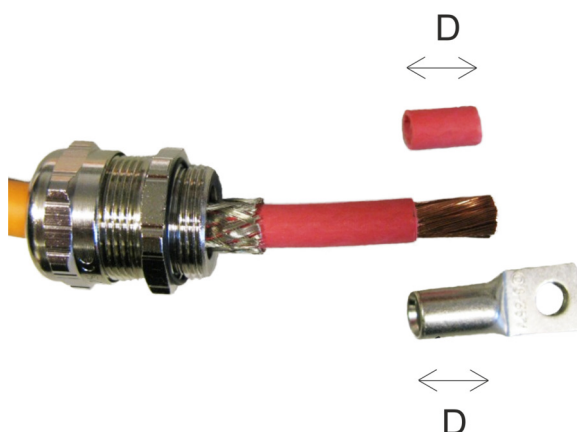

7. a) Make sure that the conducting strands of the cable are completely free of silicone and other impurities. Insert cable conductors fully into cable lug. Make sure that the cable lug is not too loose and that all conductors fit inside the lug. If not, check from the part list that you are using the correct cable lugs.
- b) Always use the crimping tool of the cable lug manufacturer. Before crimping, check the cable lug size from the lug (e.g. 35-8 is 35 mm²) and select the same size dies for the crimping tool. Use hexagonal dies.
- c) Crimp the cable lug at least twice in different places starting as near to the flat part of the lug as possible and towards the barrel part of the lug. Make sure that the cable does not slip out from the lug while crimping.
- d) Remove any excess compound emerging from the sides of the cable lugs after the crimping. Verify that the cable lug is evenly compressed with clear hexagonal crimps and that no conductors are broken. See Figure below.

Installation

Connecting cable lug



8. Cut piece of shrink tube and shrink it over the cable lug and braid screen as shown in Figure below. This is done to keep the braid screen in place and for extra insulation.

	<p>The shrink tube must be specified for operating temperature range from -40°C to 150°C. Self gluing shrink tube is recommended.</p>
--	--

Shrink tube



9. Insert the cable through the corresponding hole in the connection box and connect the cable lug to the connection point. Use spring washer between the cable lug and the connection screw or nut. Example of the connection is shown in Figure below. Do not tighten the connection at this point to ensure fitting of the cable gland.

	<p>Make sure that there is at least 10 mm air gap between the cable lug and other metallic structures including the braid of the cable. If the air gap is smaller, use extra insulation shrink tube to cover the lug.</p>
---	--

Installation

Cable lug connection to the connection box (example only, the connection box may look different)

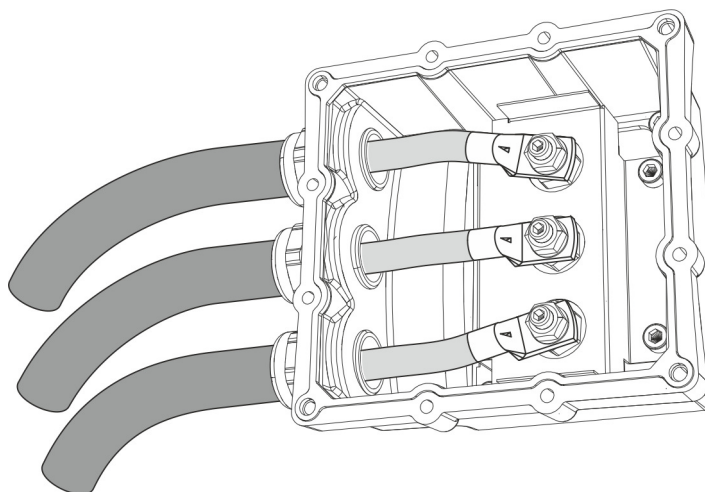

10. Screw the cable gland to the connection box as shown in the Figure above.



Tighten the cable gland from the cable gland body to enclosure. Refer to [Tightening torques](#) on page 19 for the correct torque. Then tighten the cap of the cable gland according to the instructions provided by cable gland manufacturer (recommendation Pflitsch).

11. Tighten the cable lug. Refer to [Tightening torques](#) on page 19 for the correct torque.
12. Repeat the procedure to the other cables and connection box (if the machine includes DUAL or TRI option).
13. Check that the phase connections order in the connection box is correct, that is, the corresponding phases between the inverter and the machine are connected (U, V, W correspond to the L1, L2, L3 phases).
14. Close the connection box. Tighten the connection box cover screws. See Chapter [Tightening torques](#). Use thread locking compound that makes it possible to remove the screws. (For example Loctite 221).

If you must connect the anti-condensation heater, you can leave the connection box open. See Chapter [Anti-condensation heater connections](#) on page 55.

15. Check the power cable shield grounding, see Chapter [Grounding connections](#).

Installation

Cable lug and cable gland assembly cross section

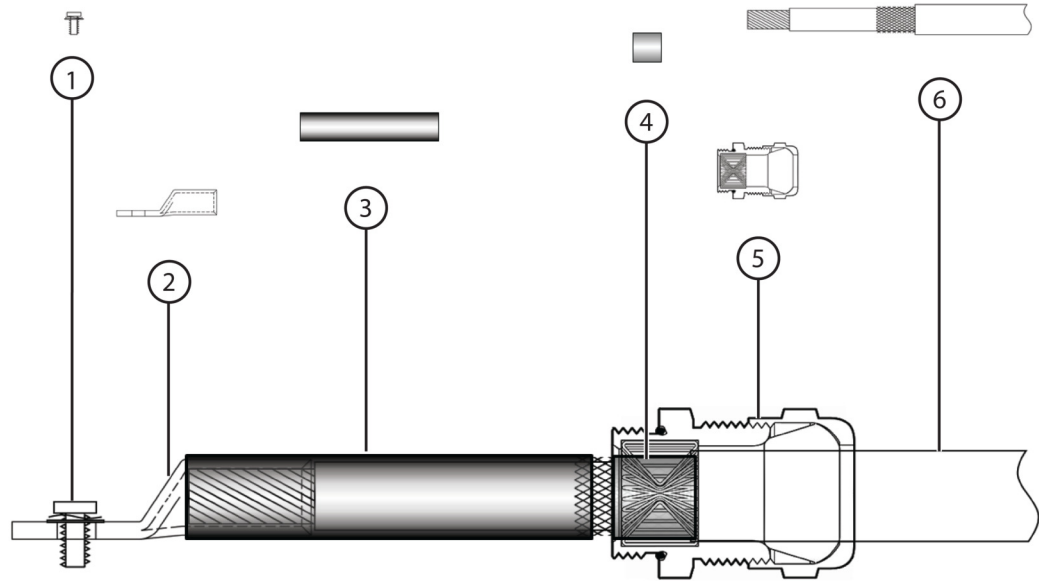

1	Cable lug bolt
2	Cable lug
3	Shrink wrap
4	Copper tape
5	Cable gland
6	Cable

Low voltage connections



IP67 level protection is reached only when connector mating part is installed and all unused pin holes are plugged in the connector mating part with the following plugs, depending on the hole size:

- DEUTSCH 0413-003-1605 (size 16)
- DEUTSCH 0413-204-2005 (size 20)

For further information, contact the connector manufacturer TE connectivity directly.

The electric machine has a connector or a connection box which is used to read out in-built temperature and rotation sensor (resolver) data from the electric machine. The temperature data comes from PT100 sensors in the stator windings and in some cases in the bearings. The rating plate has the information about the options of the electric machine: different options add sensors, and some electric machines do not have all the sensors. For more information about the options, refer to Chapter [Product naming convention](#) on page 5.

See more information and instructions about DEUTSCH connectors at <https://www.deutschconnector.com/>.

Recommended cable types for low voltage connections

Application	Cable type
Resolver cabling	Shielded cable (twisted pair)
Temperature measurement (PT100)	Shielded cable (twisted pair)

Installation

Location of the low voltage connectors in the connection box (N-end)

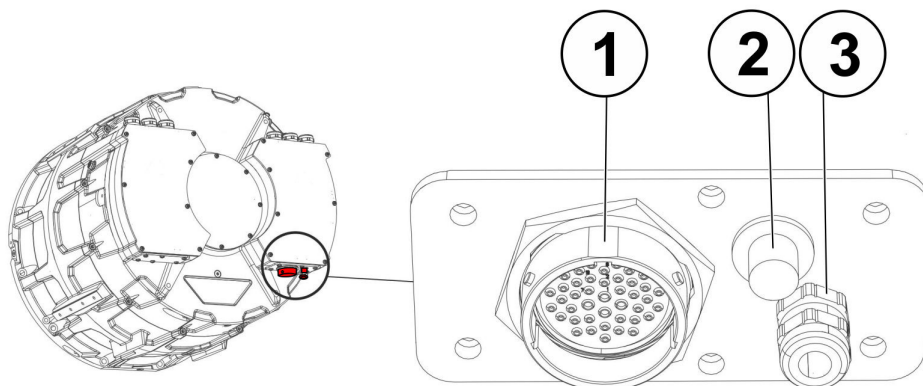

1	Low voltage (measurement signal) connector including winding temperature sensors (PT100) and resolver connections
2	Bearing temperature measurement sensor (PT100) connector in the N-end of the electric machine
3	Inlet (cable gland) for anti-condensation heater cable (see Chapter Anti-condensation heater connections on page 55)

Low voltage connector details

	<p>Deutsch HD34-24-47PE connector has two kinds of mating pins: 1 mm and 1.5 mm in diameter.</p>
--	---

Pin configuration of the Deutsch HD34-24-47PE connector

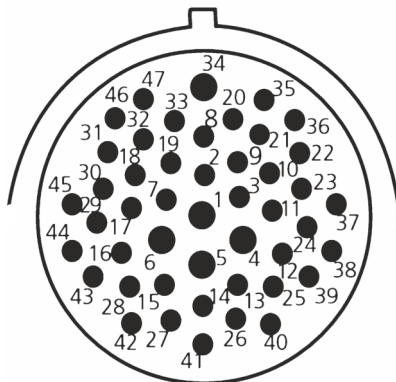

Pin configuration of the Deutsch HD34-24-47PE connector

Measurement	Description	PIN
Temperature 1	Temperature 1, PT100 (P), windings	47
	Temperature 1, PT100 (N), windings	46

Installation

Pin configuration of the Deutsch HD34-24-47PE connector (continued)

Measurement	Description	PIN
Temperature 2	Temperature 2, PT100 (P), windings	33
	Temperature 2, PT100 (N), windings	32
Temperature 3	Temperature 3, PT100 (P), windings	45
	Temperature 3, PT100 (N), windings	31
Temperature 4	Temperature 4, PT100 (P), windings, option TEMP4 + TEMP5	30
	Temperature 4, PT100 (N), windings, option TEMP4 + TEMP5	29
Temperature 5	Temperature 5, PT100 (P), windings, option TEMP4 + TEMP5	44
	Temperature 5, PT100 (N), windings, option TEMP4 + TEMP5	43
Temperature 6	Temperature 6, PT100 (P), windings, option TEMP4 + TEMP5	28
	Temperature 6, PT100 (N), windings, option TEMP4 + TEMP5	16
Temperature 7	Temperature 7, PT100 (P), windings, option TEMP5	42
	Temperature 7, PT100 (N), windings, option TEMP5	27
Temperature 8	Temperature 8, PT100 (P), windings, option TEMP5	15
	Temperature 8, PT100 (N), windings, option TEMP5	14
Temperature 9	Temperature 9, PT100 (P), windings, option TEMP5	40
	Temperature 9, PT100 (N), windings, option TEMP5	26
Temperature 10	Temperature 10, PT100 (P), windings, option TEMP5	41
	Temperature 10, PT100 (N), windings, option TEMP5	13
Temperature 11	Temperature 11, PT100 (P), windings, option TEMP5	39
	Temperature 11, PT100 (N), windings, option TEMP5	38
Temperature 12	Temperature 12, PT100 (P), windings, option TEMP5	25
	Temperature 12, PT100 (N), windings, option TEMP5	12
Resolver COS_N	Resolver, RES_COS_N, inbuilt non-contacting	35
Resolver COS_P	Resolver, RES_COS_P, inbuilt non-contacting	20
Resolver SIN_N	Resolver, RES_SIN_N, inbuilt non-contacting	36
Resolver SIN_P	Resolver, RES_SIN_P, inbuilt non-contacting	21
Resolver EXCN	Resolver, EXCN, inbuilt non-contacting	22
Resolver EXCP	Resolver, EXCP, inbuilt non-contacting	10
Resolver shield	Resolver, SHIELD/GROUND, inbuilt non-contacting	34

Bearing temperature measurement connector (optional), both ends of electric machine

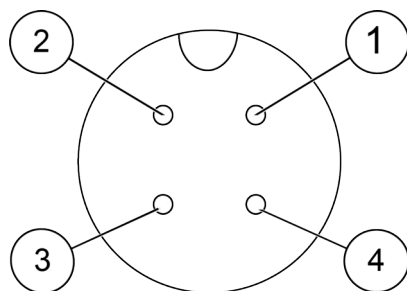

1	PT100 pin
2	PT100 pin

Installation

3	PT100 ground pin
4	PT100 ground pin

Low voltage connection box details

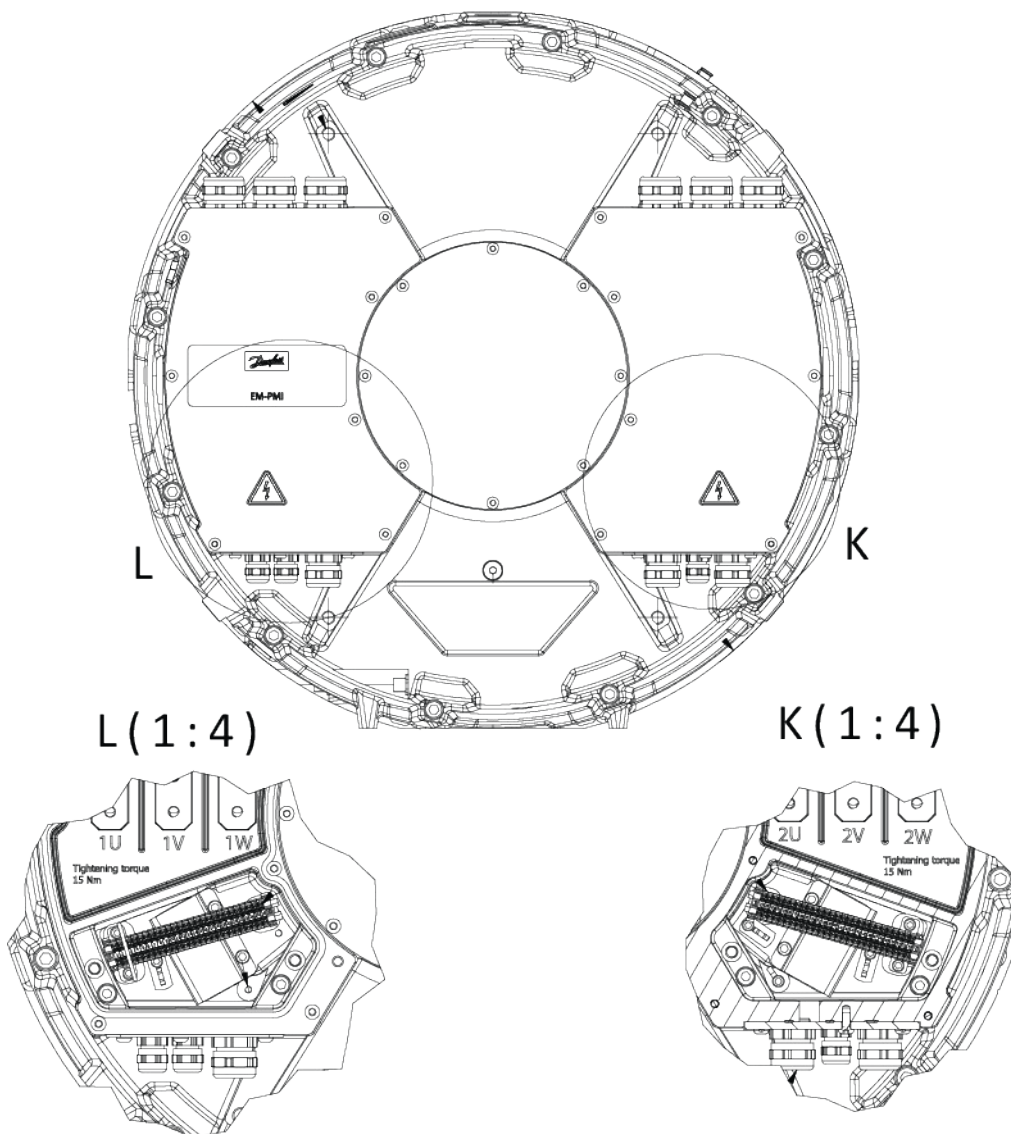

Pin configuration of LV connections (+LVB1 option)

PIN	Description
1	Heater, phase, 230 V _{AC}
2	Heater, neutral
↓	Heater, ground / protective earth, M5 screw inside connection box
3	Reserve
4	Reserve
5	Temperature 1, PT100 (P), windings
6	Temperature 1, PT100 (N), windings

Installation

Pin configuration of LV connections (+LVB1 option) (continued)

PIN	Description
7	Temperature 2, PT100 (P), windings
8	Temperature 2, PT100 (N), windings
9	Temperature 3, PT100 (P), windings
10	Temperature 3, PT100 (N), windings
11	Temperature 4, PT100 (P), windings (+TEMP4 option)
12	Temperature 4, PT100 (N), windings (+TEMP4 option)
13	Temperature 5, PT100 (P), windings (+TEMP4 option)
14	Temperature 5, PT100 (N), windings (+TEMP4 option)
15	Temperature 6, PT100 (P), windings (+TEMP4 option)
16	Temperature 6, PT100 (N), windings (+TEMP4 option)
17	Temperature 7, PT100 (P), windings (+TEMP5 option)
18	Temperature 7, PT100 (N), windings (+TEMP5 option)
19	Temperature 8, PT100 (P), windings (+TEMP5 option)
20	Temperature 8, PT100 (N), windings (+TEMP5 option)
21	Temperature 9, PT100 (P), windings (+TEMP5 option)
22	Temperature 9, PT100 (N), windings (+TEMP5 option)
23	Temperature 10, PT100 (P), windings (+TEMP5 option)
24	Temperature 10, PT100 (N), windings (+TEMP5 option)
25	Temperature 11, PT100 (P), windings (+TEMP5 option)
26	Temperature 11, PT100 (N), windings (+TEMP5 option)
27	Temperature 12, PT100 (P), windings (+TEMP5 option)
28	Temperature 12, PT100 (N), windings (+TEMP5 option)
29	Resolver, RES_COS_P, in-built non-contacting (+RES1 option)
30	Resolver, RES_COS_N, in-built non-contacting (+RES1 option)
31	Resolver, RES_SIN_P, in-built non-contacting (+RES1 option)
32	Resolver, RES_SIN_N, in-built non-contacting (+RES1 option)
33	Resolver, EXCP, in-built non-contacting (+RES1 option)
34	Resolver, EXCN, in-built non-contacting (+RES1 option)
35	Resolver, SHIELD/GROUND, in-built non-contacting (+RES1 option)
36	Temperature, PT100 (P), bearings N-end (+BTMP1 option)
37	Temperature, PT100 (N), bearings N-end (+BTMP1 option)
38	Reserve
39	Reserve
NA	D-end bearing temperature sensor with separate connector (+BTMP1 option)

Grounding connections

	<p>Ground the electric machine from its frame to make sure it functions correctly and safely.</p>
--	--

Installation

	<p>Ground the cable shields of the power cables to make sure the electric machine functions correctly and safely.</p>
	<p>Ground the cable shields of the instrumentation cables to make sure the electric machine functions correctly and safely.</p>
	<p>It is recommended to perform a ground bond test after installing the electric machine to make sure the electric machine is correctly grounded.</p>
	<p>The grounding points on the frame of the electric machine are for safety grounding, and signal cables and power cable shields have their own grounding points.</p>

The machine enclosure grounding point, safety grounding

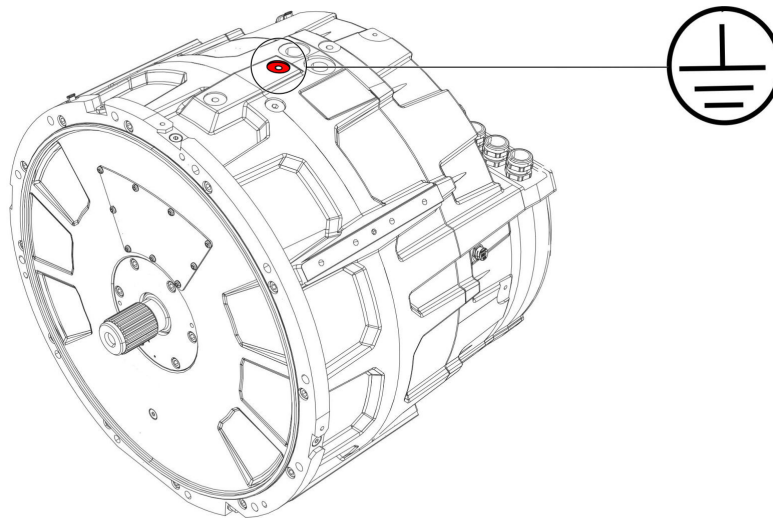

Installation

Low voltage cable grounding points

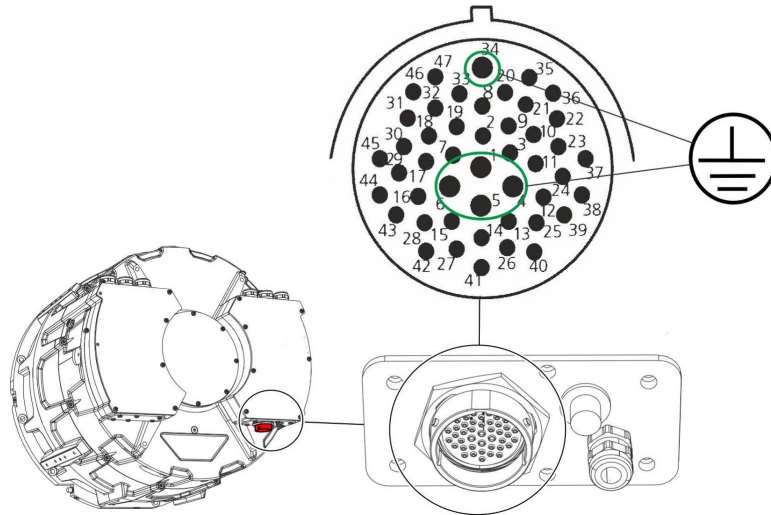

Power cable grounding through the cable gland

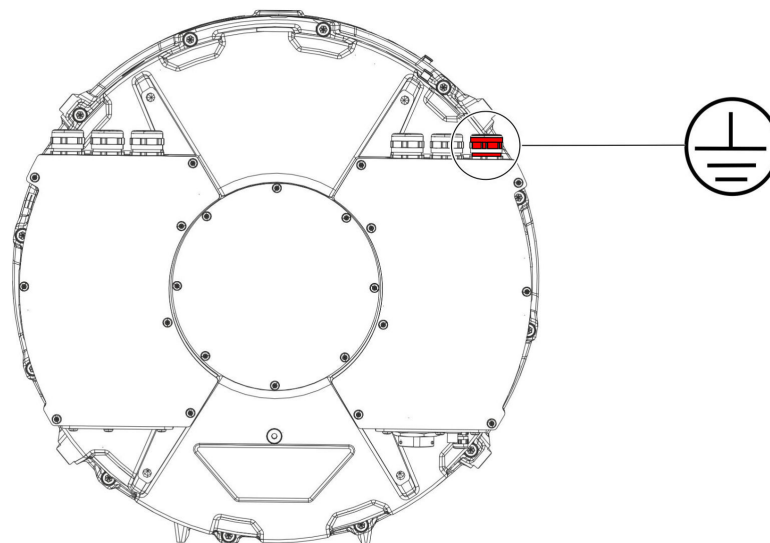

Testing the power cable shield grounding (earthing)

The power cable shields are grounded (earthed) through the cable glands to the connection box and further to the electric machine enclosure. After the cable gland assembly and power cable installations, and any time when needed, make sure that the grounding (earthing) connections are correct.

Installation

1. Connect one terminal of the measurement device to the cable shield of one power cable (in the inverter end of the cable)
2. Connect the other terminal of the measurement device to the cable shield of an other power cable. You can also use the machine enclosure grounding point for the measurement.
3. Measure the resistance between the two cable shields or between the cable shield and the enclosure grounding point.
4. Change the measurement device terminal(s) to the shield of different power cable and repeat the measurement until all cables have been measured.

Testing the low voltage (measurement signal) cable shield grounding (earthing)

The low voltage (measurement signal) cable shield connects to the ground through the connector grounding/earthing pins. After cable installation, and any time when needed, make sure that the grounding (earthing) connection is valid.

1. Connect one terminal of the measurement device to the low voltage cable shield (in the non-machine end of the cable).
2. Connect the other terminal of the measurement device to the machine enclosure grounding point.
3. Measure the resistance between the cable shield and the enclosure grounding point.

Anti-condensation heater connections



Do not run the electric machine when an anti-condensation heater is in use.

Water condensing inside the electric machine enclosure can result in failure or corrosion of the electric machine. This often happens in cooler temperatures or higher humidity areas typically in marine environment, when the machine is not running.

The electric machine can be equipped with anti-condensation heater to avoid condensation issues. The anti-condensation heater (+HEAT1) or heaters (+HEAT2) are factory assembled. The installed heater may not be used when the electric machine mains are switched on or when the electric machine is running.

The installed anti-condensation heater must be supplied with 230 Vac power. The heater connector is inside the connection box, in the lower part if it. The anti-condensation heater cable has an inlet (cable gland) next to the low voltage signal connector. See Figure below.

Installation

Anti-condensation heater connector

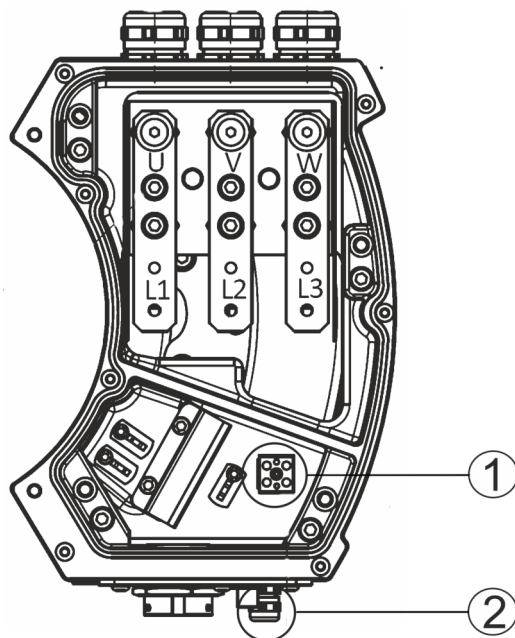

1	Anti-condensation heater connector (inside the connection box)
2	Inlet and cable gland for the anti-condensation heater cable

After the installation of the electric machine, and any time when needed, the resistance of the warming element can be measured. Connect the measurement device between the heater terminals. The resistance should be around 1 k Ω . Measuring no value, or zero value, indicates a possible failure in the heater element.

If the electric machine has an anti-condensation heater and failure is suspected, contact Danfoss representative.

Operation

	<p>Only trained and qualified personnel familiar with the relevant safety requirements are allowed to operate the electric machine.</p>
	<p>Do not use the electric machine without properly dimensioned and operating cooling system. Maximum operation temperature, current and rotational speed of the electric machine must not be exceeded to avoid permanent damage.</p>
	<p>The surface of the electric machine might be hot. Do not touch the electric machine during operation.</p>
	<p>Entanglement hazard! Do not touch the electric machine during operation.</p>
	<p>Use the anti-condensation heater, if fitted, when the electric machine is not in use. This prevents condensation and possible damage to the electric machine.</p>
	<p>Use sufficient personal protective equipment when you are near the electric machine.</p>
	<p>Read the instructions in this user guide before you install the electric machine.</p>

Operation

Operation conditions

The electric machine should be used for its intended purpose only and within limits specified by the manufacturer, concerning:

- Loading.
- Cooling.
- Speed range.
- Service interval.
- Ambient condition such as temperature and moisture.

The electric machine is designed for the following conditions:

- Ambient temperature limits: -40°C ...+65°C.
- Maximum altitude 1000 m above sea level.
- Coolant liquid must be water-glycol mixture with maximum of 50 % glycol content. See Chapter [Recommended coolants](#).
- For the maximum coolant liquid temperature at the inlet of the coolant circuit, see the product data sheet.

If electric machine operation limits are exceeded, please contact Danfoss representative.

Condition monitoring during operation

	<p>Supervise the electric machine during operation to make sure that the electric machine operates correctly and has a designed lifetime.</p>
	<p>If you notice any deviations from the normal operation, for example elevated temperatures, noise or vibration, stop the electric machine. Find the reason for the deviation and repair the electric machine. Refer to Chapter Troubleshooting on page 68.</p>
	<p>Electrical safety of the system and the end application has to be guaranteed using appropriate methods, like external insulation resistance or residual current monitoring, depending on the application.</p>
	<p>Maximum temperature of the bearings of the electric machine is: 120°C.</p>
	<p>The maximum allowed winding temperature of the electric machine is shown on the rating plate and in the data sheet.</p>

Operation

Recommended lubricants

	<p>Do not mix different types of lubricants!</p>
--	---

Grease relubricable bearings need regular greasing. For further information, see Chapter [Bearings and lubrication](#) on page 63.

The recommended grease type for the machine bearings is SKF LGHP-2 or equivalent. LGHP-2 is high performance, high temperature bearing grease. For further information, see <http://www.skf.com/>.

Recommended coolants

	<p>Ethylene glycol is a toxic compound. Avoid exposure to the coolant.</p>
	<p>Copper ions concentration of more than approx. 0.06 ppm causes <i>copper induced pitting corrosion</i>. Do not use copper components in the cooling system.</p>
	<p>Hard piping made of metal is recommended for the coolant instead of soft piping as rubber hoses.</p>
	<p>Use correct personal protective equipment when you handle the coolant.</p>

The electric machines are designed to work properly with water based coolant. Plain water with appropriate corrosive inhibitor is acceptable, for example 50 % water- 50 % glycol coolant.

Glycol coolant options:

- Ethylene glycol based Glysantin® G48® (includes also corrosion inhibitors).
- Propylene glycol based coolants, like Splash® RV&Marine antifreeze.

Emergency operation

The electric machine should be operated within the operation limits and in the conditions specified by the manufacturer. However, it can be used with some limitations in the following fault/emergency situations.

Cooling of the electric machine fails

Cooling system failure can be caused by dregs (sediment) accumulating in the cooling system tubes. Try opening the possible blockage by changing the coolant flow direction. See also Chapter [Cooling system maintenance](#).

Operation

If the cooling of the electric machine fails, limited operation is still possible with no coolant flow. The operation speed must be limited to half (1/2) of the rated speed and maximum 20 % of the nominal torque may be used. In such case, the electric machine may be operated for maximum one hour. Repair the cooling system as soon as possible. For further information, contact Danfoss representative.

The temperature measurement of the electric machine fails

The operation temperature of the electric machine is measured by PT100 temperature sensors in the electric machine windings. The temperature signals can be read out from the measurement connector of the electric machine, and connect to the temperature surveillance pin in the inverter for example. In case of a temperature measurement sensor failure in the electric machine, an additional PT100 sensor can be mounted close to the end of the windings at the low voltage (measurement signal) cable opening inside the connection box.

1. Remove the connection box cover.
2. Mount (glue) an additional PT100 temperature sensor close to the end of the windings at the opening where the signal cables are routed inside the electric machine enclosure (inside the connection box lower part). Use resin/glue specified for correct temperatures (Temp.class in the rating plate, class F / 155°C).
3. Connect the PT100 sensor to the low voltage connector (replace the failed sensor connection by the new connection).
4. Remount the connector box cover.

When reading the temperature (resistance) values from the additional sensor, add +15°C to the measured value. This gives more correct estimation of the inner temperature of the electric machine. In case of the temperature measurement failure and using additional temperature sensor, replace the electric machine as soon as possible, but no later than in two months.

Danfoss service contact information

Contact Danfoss service at <https://danfosseditron.zendesk.com/hc/en-gb> or send email to editron.service@danfoss.com.

Maintenance

This Chapter contains necessary information for the qualified and trained personnel to carry out regular maintenance work.

	<p>Do not disassemble the electric machine. Only procedures described in this user guide may be done.</p>
	<p>Only trained and qualified personnel familiar with the relevant safety requirements are allowed to do maintenance to the electric machine.</p>
	<p>Risk of electric shock when the connection box is open. Voltage may be connected to the anti-condensation heater.</p>
	<p>Use correct personal protective equipment when you are near the electric machine.</p>
	<p>Read the instructions in the user guide before you start to work with the electric machine. To make sure that the operation of the electric machine is safe and reliable, obey the maintenance instructions.</p>

Regular maintenance

	<p>Inspect the electric machine at regular intervals.</p>
--	--

Maintenance



Do not attempt to tighten bolts or screws that are not discussed in this user guide and that are not needed for normal installation and maintenance procedures. The sealing of the bolts and screws can break.

Correct supervision and maintenance of the electric machine makes sure that the electric machine has reliable operation and designed lifetime.

Maintenance schedule

Object		Check/Task	Weekly	Monthly	Yearly
General construction	Operation	Noise, vibration. If clearly increased, contact Danfoss.	X		
	Mounting	Bolt tightness. Tighten to proper value if necessary. Applies to bolts and screws that are discussed in this user guide. See Chapter Tightening torques .			X
	Bearings	Detect any unusual noise or vibration. If exists, contact Danfoss.			X
	Enclosure and connected parts	Check cleanliness. Clean if necessary. See Chapter Cleaning .		X	
	Shaft seals	Check the wear. Replace if necessary.			X
Electrical system	Cables	Wearing of the cables. Replace if necessary.		X	
	Electrical connections	Check connections. Make sure that tightening torque is correct for the cable glands. See Chapter Tightening torques .			X
	Groundings (earthings)	Check groundings (earthings). Make sure that the connection resistance is correct. Re-connect if necessary.			X
	Anti-condensation heater	Check anti-condensation heater connections and resistance, if the option is installed. If needed, contact Danfoss.			X
Cooling system	Operation	Functioning. Cooling system functions as specified.	X		
	Tubing and connection tightness	No visible leakage. If leaking, tighten the connections, or replace parts.		X	
	Ventilation plug	Cleanliness. Clean if necessary. See Chapter Cleaning .		X	
	Coolant flow	Coolant flow direction. It is recommended to change the coolant flow direction by changing the connections or flow direction from the pump. See Chapter Cooling system maintenance .			X
	Coolant quality	Coolant as specified. Correct glycol used, and water/glycol mixture correct. Refill if necessary. See Chapter Cooling system maintenance .			X
Lubrication	Relubrication (grease lubricated bearings)	Relubricate depending on the use (see Chapter Bearings and lubrication). Maximum relubrication interval is six months.		X	

Cleaning



Never open or remove the watertight ventilation plugs. Clean them only from the outside.



Risk of electric shock if the electric machine is cleaned against instructions allowing water to go in to the electric machine.

Keep the electric machine clean. For cleaning, use non-abrasive and non-corrosive cleaning products.

Maintenance

Make sure that the detergent may be used for aluminum.

When pressure washing the electric machine, make sure that the water spray does not directly hit the gaskets.

Ventilation plugs

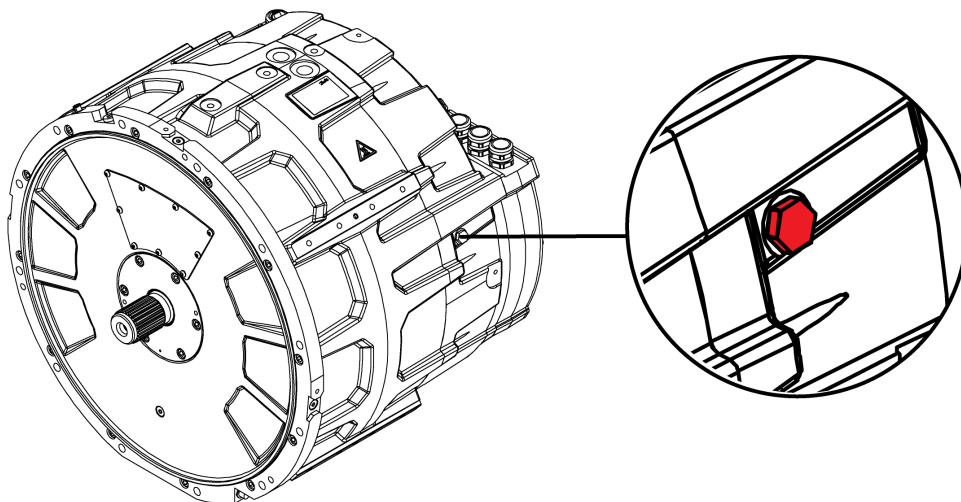

Bearings and lubrication

Grease relubricable bearings





	<p>The grease relubricable bearings need regular greasing. Follow the relubrication interval and instructions described in this Chapter.</p>
	<p>Lubricants can cause skin irritation and eye inflammation. Follow all safety precautions specified by the manufacturer of the lubricant.</p>
	<p>Make sure that the automatic greasing and the oil lubrication function correctly after you start the electric machine.</p>
	<p>The bearing type of the electric machine can be found on the rating plate of the electric machine.</p>

Maintenance

	<p>It is recommended to have a piping for the grease exiting the electric machine. The grease exit hole is often in an inconvenient location when the electric machine is installed.</p>
---	---

The bearing type for the electric machine is 6214/C3 (non-insulated bearings) or 6214/C3 HC5 (insulated bearing). See the recommended lubricant in Chapter [Recommended lubricants](#) on page 59.

Bearing relubrication

	<p>Beware of rotating parts. Do not touch the electric machine during operation.</p>
	<p>The surface of the electric machine can be hot. Use correct protective equipment (heat resistant gloves) when you handle the electric machine.</p>
	<p>The information of bearing lifetime and bearing grease lifetime are estimations only to provide a magnitude of them. The bearing lifetime and bearing grease lifetime in customer application may vary. Danfoss is not responsible for the actual bearing lifetime in use. For further information, contact Danfoss representative.</p>
	<p>The maximum relubrication interval in operation is six months. The amount of grease per relubrication is 20 g.</p>

The relubrication interval depends on the used rotation speed and bearing temperature, and is presented in the Figure below. The different curves represent different bearing temperatures. The higher the temperature is and the higher the rotation speed is, the lower the relubrication interval is.

Maintenance

Relubrication interval of the machine compared to rotation speed and bearing temperature

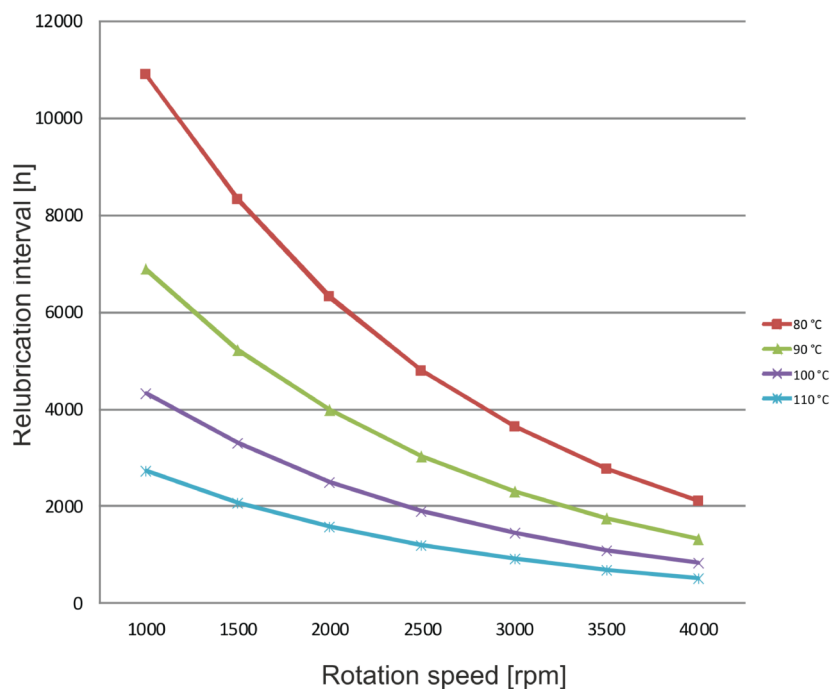

Relubrication interval of the machine compared to rotation speed and bearing temperature, vertical installation

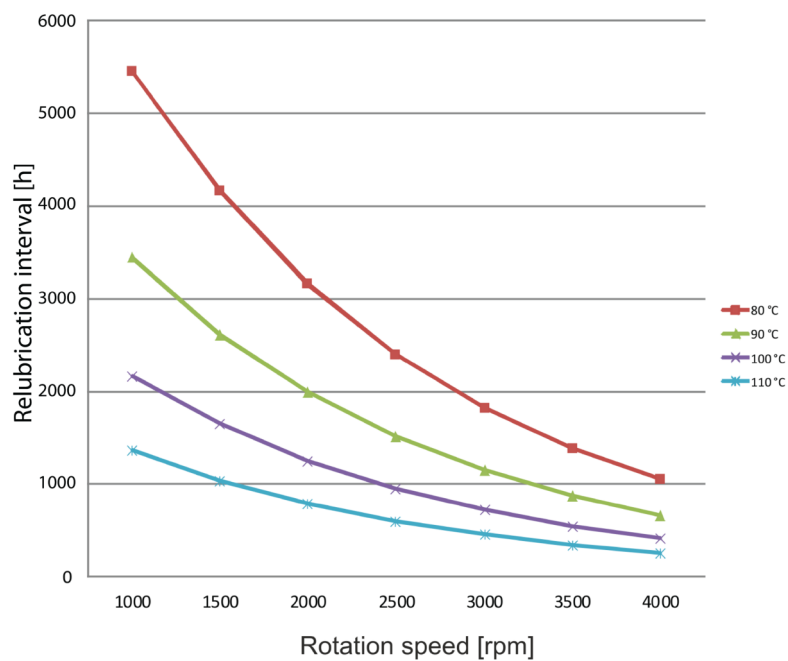

For more information about the location of grease nipples and grease escape holes, see Chapter [Connections and interfaces](#) on page 16.

Maintenance

Bearing relubrication:



It is normal if no grease exits the electric machine. This is because the cavities inside the electric machine can hold a lot of grease.

1. Make sure that the electric machine has reached its operating temperature.
2. Remove the plugs from the grease escape hole(s).
3. Open the grease nipple plug(s).
4. Use grease piston to enter specific amount of grease into the grease nipple.
5. After re-greasing, the electric machine must be restarted with a short idle time of 10 minutes at 10...15% of the rated speed, so that the grease is transferred and settled to the rolling surfaces of the bearing.
6. Install the plug(s) on the grease nipple(s) and on the grease escape hole(s).

Cooling system maintenance

It is recommended to change the direction of the coolant liquid flow yearly. This is done by changing the order of the coolant connections, or changing the coolant pump direction. The reason for changing the coolant flow direction is to prevent possible dregs (sediment) accumulating to the cooling system.

The quality of the coolant must be checked yearly. The mixture of coolant fluid must be according to specification. See Chapter [Recommended coolants](#).

Dismounting

	Make sure that the mating structure is not damaged. Do not pluck any bores or use at headed bolts or rods for pushing the electric machine out of the mating structure.
---	--

For dismounting the electric machine, follow the Steps below.

1. Prepare the electric machine for lifting, for more information refer to Chapter [Lifting](#) on page 26. Support the electric machine with lifting slings when dismounting.
2. Loosen the mounting bolts. For more information refer to Chapter [Mounting the electric machine](#) on page 35.
3. If force is required, use the bores in D-end flange to push the electric machine out from the mating structure, or use some other method that does not damage the electric machine.
4. Lift the electric machine off. Support the electric machine when lifting.

Troubleshooting

Some difficulties may occur while operating the electric machine. Possible causes and actions are given in the Table below. If the situation occurs, it should be corrected as soon as possible. These instructions do not cover all details or variations in the equipment nor provide information for every possible condition to be met in connection with installation, operation or maintenance.

For more information, contact Danfoss service at <https://danfosseditron.zendesk.com/hc/en-gb> or send email to editron.service@danfoss.com.

Troubleshooting chart

Symptom	Possible cause	Action
Excessive vibration, noise	Imbalance at the connected electric machine or the powertrain components.	Check the balance and installation of the drivetrain components.
	Misalignment between the electric machine and the used device.	Check the shaft connections and couplings. Ensure that the alignment is within the specifications listed in Chapter Shaft alignment and load on page 23.
	Attachment bolts are loose.	Replace and tighten the bolts.
	Clearance at the spline connection.	Check the spline connection.
	Imbalance at the electric machine.	Contact local Danfoss representative.
	Particles inside the electric machine.	
	Bearing damage.	
	Inadequate lubrication (grease lubricated bearings).	Apply bearing lubricant/grease. See Chapter Bearings and lubrication . Contact local Danfoss representative for further information.
Bearing temperature rise	Inadequate lubrication (grease lubricated bearings).	Apply bearing lubricant/grease. See Chapter Bearings and lubrication .
	Too much grease in the bearing housing (grease lubricated bearings).	Open grease escape valve and let the electric machine run for 10 min. Clean the grease escape channel from solidified grease using brush if necessary.
	Incorrect bearing grease.	Check that the used grease is of correct type.
	Overloaded bearing.	Check that the system is not causing excess force or vibration to the machine bearings. Check the alignment of the machine shaft, see Chapter Shaft alignment and load on page 23.
	Bearing damage.	Contact local Danfoss representative for further information.
	Incorrect mounting option	Check motor mounting orientation and confirm that the motor has the correct option (vertical or horizontal mounting).
Electric machine overheating	Overload.	Reduce load. Check the machine rating plate and ensure that inverter limits are set accordingly.
	Cooling system failure.	Check the cooling system integrity, flow and fluid temperature. Change the cooling flow direction to flush the cooling system from sediment that has possibly accumulated. See also Chapter Emergency operation .
	Leakage in the cooling system.	Check the cooling system circuit and tighten the leaking connections.
	Rigid particle inside the machine cooling channel.	Try pulsating coolant to open the channels. Contact local Danfoss representative.
	Wrong machine parameters in the inverter.	Check and correct the machine parameters in the inverter.
	Damaged winding.	Measure the insulation resistance. Measure the winding resistance with a high-precision DC resistance meter and compare to manufacturer specifications. Replace the electric machine if necessary.
	Inverter switching frequency too low.	If other than a Danfoss Editron inverter is used, ensure that the switching frequency is at least equal to the required minimum switching frequency of the motor. See corresponding product data sheet.

Troubleshooting

Troubleshooting chart (continued)

Symptom	Possible cause	Action
Connection box and / or motor cables overheating	Cable lug bolts loose.	Check torque of cable lug bolts. See also Chapter Power connections on page 39.
	Cable diameter too small.	Replace power cables with appropriate cable type.
	Cable lug crimps insufficient or incorrect.	Replace cable lugs. Use recommended cable lugs and crimping tools.
	Contamination or insulating substance between cable lug and bus bar.	Check that the contact surfaces of the bus bars and cable lugs are clean and undamaged. Ensure there is no grease, thread locking compound, dirt or other foreign substances between the bus bar and cable lug.
Significant lubricant leak	Worn radial lip seal.	Contact local Danfoss representative.
	Block at the grease outlet channel.	Clean the grease escape channel from solidified grease using brush if necessary.
Electric machine does not work properly or the performance is poor	Wrong electric machine parameters in the inverter.	Check and correct the electric machine parameters from the inverter. See inverter user manual and other relevant documentation.
	Demagnetization of magnets due to overheating.	Check that the back-EMF of the motor is within specifications. Contact local Danfoss representative. Replace the electric machine if necessary.
	Bearing fault.	Check the bearing temperature, lubrication and conditions. Contact local Danfoss representative for further information.
	Insulation or winding fault.	Measure the insulation resistance, refer to the manufacturer limits. See Chapter Insulation resistance test . Measure the winding resistance with a high-precision DC resistance meter and compare to manufacturer specifications. Replace the electric machine if necessary.
Moisture and / or corrosion inside the connection box or motor	Cable glands installed incorrectly.	Check tightening torque and sealing of the cable glands.
	Power cables installed incorrectly.	Check cable installation and sealing with cable glands.
	Connection box cover bolts are too loose, too tight, or cover seal is damaged.	Check the integrity of the seal on the connection box cover. Tighten the cover bolts to the specified torque.
	Low voltage connector damaged or not connected.	Contact local Danfoss representative.
	Breather cap blocked.	Check that the breather cap of the electric machine is not submerged in liquid, painted, or covered by any object
Anti-condensation heater failure	The heater element is faulty.	Measure the resistance of the heater element. See Chapter Anti-condensation heater connections on page 55. If the heater is faulty, contact local Danfoss representative.
Temperature measurement failure	The PT100 sensor is faulty.	Measure the resistance of the PT100 sensor, see Chapter Low voltage connections . If the sensor is faulty, read out the signal from another sensor. Contact local Danfoss representative. See also Chapter Emergency operation .
Resolver sensor failure	Resolver wiring is faulty.	Check the wiring of the resolver and make sure that a shielded and twisted pair cable is used with the correct pairing of the signals.
	Resolver sensor is damaged.	Contact local Danfoss representative.

Aftersales

Service policy

Maintenance and service of the electric machine is limited to the procedures described in this user guide.

If the electric machine has service parts available, you can find them in Chapter [Service parts](#) on page 70.

For further information, go to <https://danfosseditron.zendesk.com/hc/en-gb> or send email to editron.service@danfoss.com.

Service parts

The recommended service parts are listed in this Section. Quantity describes the number of components in a single electric machine. Maintenance procedures not described in this user guide require special tools and instructions. Contact Danfoss for more information and purchasing.

EM-PMI540-T1500/T2000 Bearing kit (Non-insulated)

Quantity (pcs)	Part	Type	Order number
	EM-PMI540-T1500/T2000-BEARING-KIT-NON-INSULATED		11279444
2	Washer. Locking	SKF MB14	
2	Nut. Lock	SKF KM14	
2	Bearing. Deep groove ball (non-insulated)	SKF 6214 C3	
1	Spring. Wave	LESJOFORS 4833	
2	Seal. O-ring	124,5 x 3 NBR 70	
1	Seal. Radial lip (D-end)	55 x 85 x 8 TRELLEBORG, TRAD00550-4V012	
1	Seal. Radial lip (N-end)	TRELLEBORG FORSHEDA TWVA00650-VDT50	
1	Seal. Radial lip, N-end (+NE4)	60 x 80 x 8 FKM, TRELLEBORG, TREB00600-VCBV	
6	Bolt. Socket head	M10 x 40 DIN 912 A4	
6	Washer. Sealing	U 10,7 x 17 x 1,5 Zinked	
6	Bolt. Socket head	M8 x 50 DIN 912 Zinked	
1	Seal. O-ring (D-end bearing shield)	180 x 4, NBR70	
1	Seal. O-ring (N-end bearing shield)	205 x 3, NBR70	
1	Seal. Gasket (N-end cover plate)		

Aftersales

EM-PMI540-T1500/T2000 Bearing kit (+BIN)

Quantity (pcs)	Part	Type	Order number
EM-PMI540-T1500/T2000-BEARING-KIT-BIN			11279447
2	Washer. Locking	SKF MB14	
2	Nut. Lock	SKF KM14	
1	Bearing. Deep groove ball (insulated)	SKF 6214 HC5C3 (hybrid bearing)	
1	Spring. Wave	LESJOFORS 4833	
2	Seal. O-ring	124,5 x 3 NBR 70	
1	Bearing. Deep groove ball (non-insulated)	SKF 6214 C3	
1	Seal. Radial lip (D-end)	55 x 85 x 8, TRELLEBORG, TRAD00550-4V012	
1	Seal. Radial lip (N-end)	TRELLEBORG FORSHEDA TWVA00650-VDT50	
1	Seal. Radial lip, N-end (+NE4)	60 x 80 x 8 FKM, TRELLEBORG, TREB00600-VCBV	
6	Bolt. Socket head	M10 x 40 DIN 912 A4	
6	Washer. Sealing	U 10,7 x 17 x 1,5 Zinked	
6	Bolt. Socket head	M8 x 50 DIN 912 Zinked	
1	Seal. O-ring (D-end bearing shield)	180 x 4, NBR70	
1	Seal. O-ring (N-end bearing shield)	205 x 3, NBR70	
1	Seal. Gasket (N-end cover plate)		

Aftersales

EM-PMI540-T1500/T2000 Bearing kit (+BIA)

Quantity (pcs)	Part	Type	Order number
EM-PMI540-T1500/T2000-BEARING-KIT-BIA			11279448
2	Washer. Locking	SKF MB14	
2	Nut. Lock	SKF KM14	
1	Bearing. Deep groove ball (insulated)	SKF 6214 HC5C3 (hybrid bearing)	
1	Spring. Wave	LESJOFORS 4833	
2	Seal. O-ring	124,5 x 3 NBR 70	
1	Bearing. Deep groove ball (insulated)	SKF 6214 HC5C3 (hybrid bearing)	
1	Seal. Radial lip (D-end)	55 x 85 x 8, TRELLEBORG, TRAD00550-4V012	
1	Seal. Radial lip (N-end)	TRELLEBORG FORSHEDA TWVA00650-VDT50	
1	Seal. Radial lip, N-end (+NE4)	60 x 80 x 8 FKM, TRELLEBORG, TREB00600-VCBV	
6	Bolt. Socket head	M10 x 40 DIN 912 A4	
6	Washer. Sealing	U 10,7 x 17 x 1,5 Zinked	
6	Bolt. Socket head	M8 x 50 DIN 912 Zinked	
1	Seal. O-ring (D-end bearing shield)	180 x 4, NBR70	
1	Seal. O-ring (N-end bearing shield)	205 x 3, NBR70	
1	Seal. Gasket (N-end cover plate)		

EM-PMI540-T1500/T2000 Grease channel kit

Quantity (pcs)	Part	Type	Order number
EM-PMI540-T1500/T2000-GREASE-CHANNEL-KIT			11279450
2	Grease nipple (D-/N-end)	DIN 71412, M12 x 1.5, straight	
2	Cover. Grease nipple	TECALEMIT 351010022	
2	Plug for Grease escape hole	M12 x 1.5 24-HFM-12	
1	Plug. Ventilation	Amphenol art. no. VENT-MS1NMS-O8001	

EM-PMI540-T1500/T2000 Connection box cover kit

Quantity (pcs)	Part	Type	Order number
EM-PMI540-T1500/T2000-CONNECTION-BOX-COVER-KIT			11279451
1	Connection box cover plate. Right side (includes extruded gasket)		
1	Connection box cover plate. Left side (includes extruded gasket)		
14	Bolt. Socket head	M6 x 16 ISO 7380 Zinked	

Aftersales

EM-PMI540-T1500/T2000/T3000/T4000 Cable gland kit

Quantity (pcs)	Part	Type	Order number
	EM-PMI540-T1500/T2000/T3000/T4000-CABLE-GLAND-KIT		11279443
3	Cable glands	M32 x 1,5 BG232MSTRI PFLITSCH	

Disposal

Dispose of the electric machine and any of its parts by appropriate means in accordance with local laws and regulations.

Storage, installation and maintenance checklists

Electric machine installation checklist

Date:

Electric machine and customer information

Customer:	Electric machine type (from the rating plate):
Customer reference:	Electric machine serial number:
Service reference:	Date installed:

N.A = Procedure not applicable PASS = Procedure passed FAIL = Procedure failed

Installation checklist

	Approval	N.A	PASS	FAIL
General				
Electric machine type is correct		<input type="checkbox"/>	<input type="checkbox"/>	<input type="checkbox"/>
Electric machine is undamaged		<input type="checkbox"/>	<input type="checkbox"/>	<input type="checkbox"/>
Insulation resistance check For more information, see Insulation resistance test on page 31.	Reference value of 150 MΩ must be exceeded at reference ambient temperature 25°C (measured with 500 V _{DC} / 1 min insulation resistance test).	<input type="checkbox"/>	<input type="checkbox"/>	<input type="checkbox"/>
Environmental conditions as specified (see data sheet)		<input type="checkbox"/>	<input type="checkbox"/>	<input type="checkbox"/>
Mechanical installation				
Supporting structure as required		<input type="checkbox"/>	<input type="checkbox"/>	<input type="checkbox"/>
Shaft alignment as specified (see chapter Shaft alignment and load).		<input type="checkbox"/>	<input type="checkbox"/>	<input type="checkbox"/>
Cooling circuit connected and coolant flowing		<input type="checkbox"/>	<input type="checkbox"/>	<input type="checkbox"/>
Used coolant:				
Power connections				
Cable gland assembly as specified (cable gland to cables) with correct cable diameter		<input type="checkbox"/>	<input type="checkbox"/>	<input type="checkbox"/>
Cable lug air cap (to metallic structures)	≥10 mm	<input type="checkbox"/>	<input type="checkbox"/>	<input type="checkbox"/>
Cable lug tightening torque (to the bus bar)	15 Nm	<input type="checkbox"/>	<input type="checkbox"/>	<input type="checkbox"/>
Connection box cover bolts tightening torque	4 Nm	<input type="checkbox"/>	<input type="checkbox"/>	<input type="checkbox"/>
Grounding				
Electric machine enclosure grounding connected		<input type="checkbox"/>	<input type="checkbox"/>	<input type="checkbox"/>
Low voltage cable shield grounding connected		<input type="checkbox"/>	<input type="checkbox"/>	<input type="checkbox"/>
Power cable shield connection resistances to ground (electric machine enclosure) measured and valid		<input type="checkbox"/>	<input type="checkbox"/>	<input type="checkbox"/>

Storage, installation and maintenance checklists

Installation checklist (continued)

	Approval	N.A	PASS	FAIL
Low voltage cable shield grounding resistances measured and valid		<input type="checkbox"/>	<input type="checkbox"/>	<input type="checkbox"/>
Notes: <ul style="list-style-type: none"> • • • • • • • • • • • • • • Date: Signature:				

Do not try to tighten bolts or screws that are not discussed in the product manual and that are not needed for the normal installation procedures. Sealing of the screws may break.

Electric machine weekly maintenance checklist

Date:

Electric machine and customer information

Customer:	Electric machine type (from the rating plate):
Customer reference:	Electric machine serial number:
Service reference:	Date installed:

N.A = Procedure not applicable PASS = Procedure passed FAIL = Procedure failed

Electric machine weekly maintenance checklist

	N.A	PASS	FAIL
General construction			
Noise or vibration during operation in general	<input type="checkbox"/>	<input type="checkbox"/>	<input type="checkbox"/>
Cooling system			

Storage, installation and maintenance checklists

Electric machine weekly maintenance checklist (continued)

	N.A	PASS	FAIL
Functioning of the cooling system in general	<input type="checkbox"/>	<input type="checkbox"/>	<input type="checkbox"/>
Notes: <ul style="list-style-type: none"> • • • • • • • • • • • • 			

Electric machine monthly maintenance checklist

Date:

Electric machine and customer information

Customer:	Electric machine type (from the rating plate):
Customer reference:	Electric machine serial number:
Service reference:	Date installed:

N.A = Procedure not applicable PASS = Procedure passed FAIL = Procedure failed

Electric machine monthly maintenance checklist

	N.A	PASS	FAIL
General construction			
Noise or vibration during operation in general	<input type="checkbox"/>	<input type="checkbox"/>	<input type="checkbox"/>
Cleanliness of the enclosure and connected parts	<input type="checkbox"/>	<input type="checkbox"/>	<input type="checkbox"/>
Electrical system			
Weariness of the cables	<input type="checkbox"/>	<input type="checkbox"/>	<input type="checkbox"/>
Insulation monitoring	Continuous insulation monitoring. (It is recommended to use continuous insulation monitoring for the whole system where electric machine is used.)		
Encoder mounting	<input type="checkbox"/>	<input type="checkbox"/>	<input type="checkbox"/>
Cooling system			
Functioning of the cooling system in general	<input type="checkbox"/>	<input type="checkbox"/>	<input type="checkbox"/>
Tightness of the ventilation plug	<input type="checkbox"/>	<input type="checkbox"/>	<input type="checkbox"/>

Storage, installation and maintenance checklists

Electric machine monthly maintenance checklist (continued)

	N.A	PASS	FAIL
Cleanliness of the ventilation plug	<input type="checkbox"/>	<input type="checkbox"/>	<input type="checkbox"/>
Notes: <ul style="list-style-type: none"> • • • • • • • • • • • • • • 			

Electric machine yearly maintenance checklist

Date:

Electric machine and customer information

Customer:	Electric machine type (from the rating plate):
Customer reference:	Electric machine serial number:
Service reference:	Date installed:

N.A = Procedure not applicable PASS = Procedure passed FAIL = Procedure failed

Electric machine yearly maintenance checklist

	Acceptance	N.A	PASS	FAIL
General construction				
Noise or vibration during operation in general		<input type="checkbox"/>	<input type="checkbox"/>	<input type="checkbox"/>
Mounting bolt tightness				
Cleanliness of the enclosure and connected parts		<input type="checkbox"/>	<input type="checkbox"/>	<input type="checkbox"/>
Electrical system				
Weariness of the cables		<input type="checkbox"/>	<input type="checkbox"/>	<input type="checkbox"/>
Electrical connections in general		<input type="checkbox"/>	<input type="checkbox"/>	<input type="checkbox"/>
Cable lug tightening torque (to the bus bar)	15 Nm	<input type="checkbox"/>	<input type="checkbox"/>	<input type="checkbox"/>
Connection box cover bolts tightening torque	4 Nm	<input type="checkbox"/>	<input type="checkbox"/>	<input type="checkbox"/>
Cooling system				
Coolant flow direction changed and connection checked		<input type="checkbox"/>	<input type="checkbox"/>	<input type="checkbox"/>
Coolant quality as specified		<input type="checkbox"/>	<input type="checkbox"/>	<input type="checkbox"/>
Used coolant:				
Functioning of the cooling system in general		<input type="checkbox"/>	<input type="checkbox"/>	<input type="checkbox"/>
Tightness of the tubing and connections (no leakages)		<input type="checkbox"/>	<input type="checkbox"/>	<input type="checkbox"/>

Storage, installation and maintenance checklists

Electric machine yearly maintenance checklist (continued)

	Acceptance	N.A	PASS	FAIL
Cleanliness of the ventilation plug	<input type="checkbox"/>	<input type="checkbox"/>	<input type="checkbox"/>	<input type="checkbox"/>
Grounding				
Power cable shield connection resistances to ground (electric machine enclosure) checked	<input type="checkbox"/>	<input type="checkbox"/>	<input type="checkbox"/>	<input type="checkbox"/>
Low voltage cable shield grounding resistances checked	<input type="checkbox"/>	<input type="checkbox"/>	<input type="checkbox"/>	<input type="checkbox"/>
Connection to grounding points checked	<input type="checkbox"/>	<input type="checkbox"/>	<input type="checkbox"/>	<input type="checkbox"/>
Notes: <ul style="list-style-type: none"> • • • • • • • • • • • • • • • 				

Do not try to tighten bolts or screws that are not discussed in the product manual and that are not needed for the normal installation procedures. Sealing of the screws may break.

For cleaning instructions, refer to Chapter [Cleaning](#) on page 62.

Used service parts

Part description	Part type	Quantity	Item (order) number
–			
–			
–			
–			
–			
Notes: <ul style="list-style-type: none"> • • • • • • • • • • • • • • • 			
Date: Signature:			

Electric machine storage checklist

Date:

Storage, installation and maintenance checklists

Electric machine and customer information

Customer:	Electric machine type (from the rating plate):
Customer reference:	Electric machine serial number:
Service reference:	Date installed:

This storage checklist is used when storing the electric machine. Regular inspection is required. See specifications for storage in this User Guide or in the Data Sheet.

Fill in the date of each inspection to the Table below.

Storage checklist

Procedure	Date	Date	Date	Date	Date
Storage base as specified (vibration free)					
Storage temperature and humidity as specified					
Electric machine type and serial number is correct					
Electric machine supported correctly					
Corrosion protection of non-painted surfaces (for example shaft-end and grounding points)					
Insulation resistance (test insulation resistance every three months in storage)					
Shaft rotated as specified (10 rotations monthly)					

Products we offer:

- Cartridge valves
- DCV directional control valves
- Electric converters
- Electric machines
- Electric motors
- Gear motors
- Gear pumps
- Hydraulic integrated circuits (HICs)
- Hydrostatic motors
- Hydrostatic pumps
- Orbital motors
- PLUS+1® controllers
- PLUS+1® displays
- PLUS+1® joysticks and pedals
- PLUS+1® operator interfaces
- PLUS+1® sensors
- PLUS+1® software
- PLUS+1® software services, support and training
- Position controls and sensors
- PVG proportional valves
- Steering components and systems
- Telematics

Danfoss Power Solutions is a global manufacturer and supplier of high-quality hydraulic and electric components. We specialize in providing state-of-the-art technology and solutions that excel in the harsh operating conditions of the mobile off-highway market as well as the marine sector. Building on our extensive applications expertise, we work closely with you to ensure exceptional performance for a broad range of applications. We help you and other customers around the world speed up system development, reduce costs and bring vehicles and vessels to market faster.

Danfoss Power Solutions – your strongest partner in mobile hydraulics and mobile electrification.

Go to www.danfoss.com for further product information.

We offer you expert worldwide support for ensuring the best possible solutions for outstanding performance. And with an extensive network of Global Service Partners, we also provide you with comprehensive global service for all of our components.

Local address:

Hydro-Gear

www.hydro-gear.com

Daikin-Sauer-Danfoss

www.daikin-sauer-danfoss.com

**Danfoss
Power Solutions (US) Company**
2800 East 13th Street
Ames, IA 50010, USA
Phone: +1 515 239 6000

**Danfoss
Power Solutions GmbH & Co. OHG**
Krokamp 35
D-24539 Neumünster, Germany
Phone: +49 4321 871 0

**Danfoss
Power Solutions ApS**
Nordborgvej 81
DK-6430 Nordborg, Denmark
Phone: +45 7488 2222

**Danfoss
Power Solutions Trading
(Shanghai) Co., Ltd.**
Building #22, No. 1000 Jin Hai Rd
Jin Qiao, Pudong New District
Shanghai, China 201206
Phone: +86 21 2080 6201

Danfoss can accept no responsibility for possible errors in catalogues, brochures and other printed material. Danfoss reserves the right to alter its products without notice. This also applies to products already on order provided that such alterations can be made without subsequent changes being necessary in specifications already agreed. All trademarks in this material are property of the respective companies. Danfoss and the Danfoss logotype are trademarks of Danfoss A/S. All rights reserved.