



130R1294

VLT® AutomationDrive FC 360

90–315 kW, Enclosure Sizes J8–J9

1 Introduction

This operating guide provides necessary information for qualified personnel to install and commission the AC drive. Read and follow the instructions to use the drive safely and professionally.

Do not dispose of equipment containing electrical components together with domestic waste. Collect it separately in accordance with local and currently valid legislation.

2 Safety

Pay particular attention to the safety instructions and general warnings to avoid the risk of death, serious injury, and equipment or property damage.

⚠ WARNING ⚠

HIGH VOLTAGE

AC drives contain high voltage when connected to AC mains input.

UNINTENDED START

The motor may start from control panel, I/O inputs, or fieldbus at any time, when the drive is connected to the AC mains.

DISCHARGE TIME

The drive contains DC-link capacitors, which can remain charged even when the drive is not powered. High voltage can be present even when the warning indicator lights are off.

- Stop the motor, and disconnect AC mains, permanent magnet type motors.
- Wait for the capacitors to discharge fully and measure it before performing any service or repair work.
- The minimum waiting time is 20 minutes.

LEAKAGE CURRENT

Leakage currents of the drive exceed 3.5 mA. Make sure that the minimum size of the ground conductor complies with the local safety regulations for high touch current equipment.

3 Installation

3.1 Mechanical Dimensions

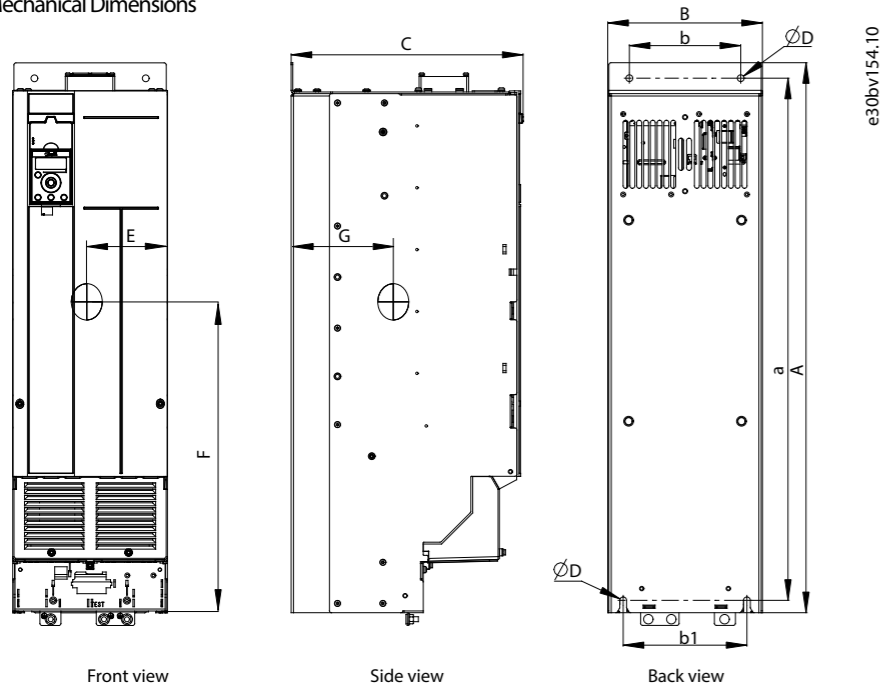

Illustration 1: Mechanical Dimensions, Enclosure Sizes J8–J9

Table 1: Power Ratings, Dimensions, and Weights for Enclosure Sizes J8–J9

Enclosure size (IP20)	Power [kW (hp)]	Height [mm (in)]			Width [mm (in)]		
		A	A ⁽¹⁾	a	B	b	b1
J8	110–160 (150–250)	889 (35.0)	909 (35.8)	844 (33.2)	250 (9.8)	180 (7.1)	200 (7.9)
J9	200–315 (300–450)	1096 (43.1)	1122 (44.2)	1051 (41.4)	350 (13.8)	280 (11.0)	271 (10.7)
Enclosure size (IP20)	Depth [mm (in)]	Mounting hole [mm (in)]	Center of gravity [mm (in)]			Maximum weight [kg (lb)]	
			C	D	E		F
J8	375 (14.8)	11 (0.4)	128 (5.0)	495 (19.5)	148 (5.8)	98 (216)	
J9	375 (14.8)	11 (0.4)	176 (6.9)	611 (24.1)	148 (5.8)	164 (362)	

Note: (1) Including decoupling plate.

3.2 Removing the Front Cover

Procedure:

- Step 1: Loosen and remove the 2 screws on the front cover.
- Step 2: Disconnect the front cover from the hooks.

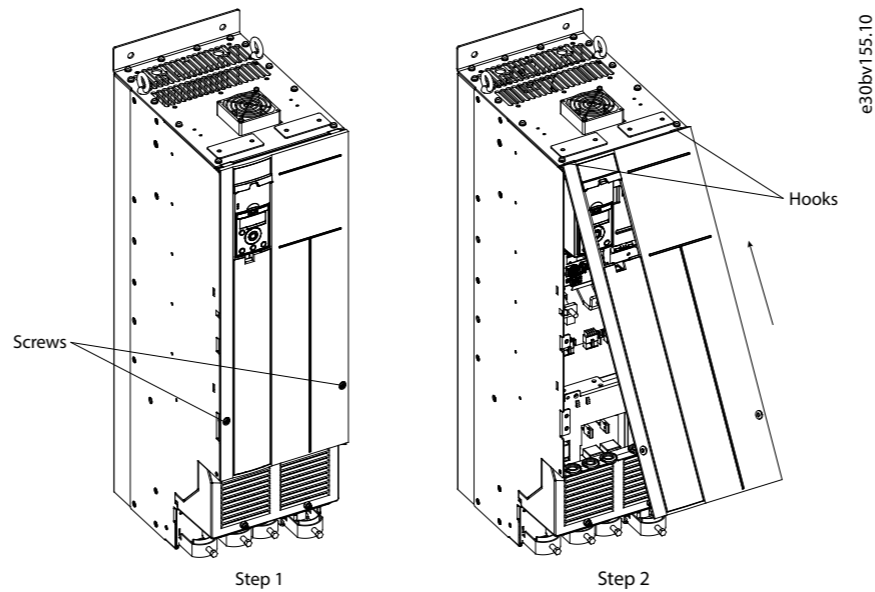

Illustration 2: Removing the Front Cover

3.3 Connecting to Mains, Motor, Control Terminals, and Relays

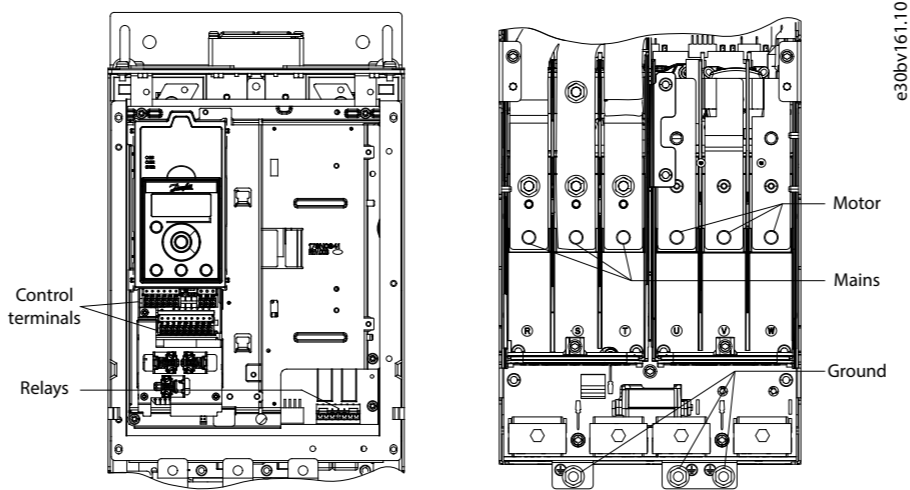

Illustration 3: Connecting to Mains, Motor, Control Terminals, and Relays

3.4 Control Terminals

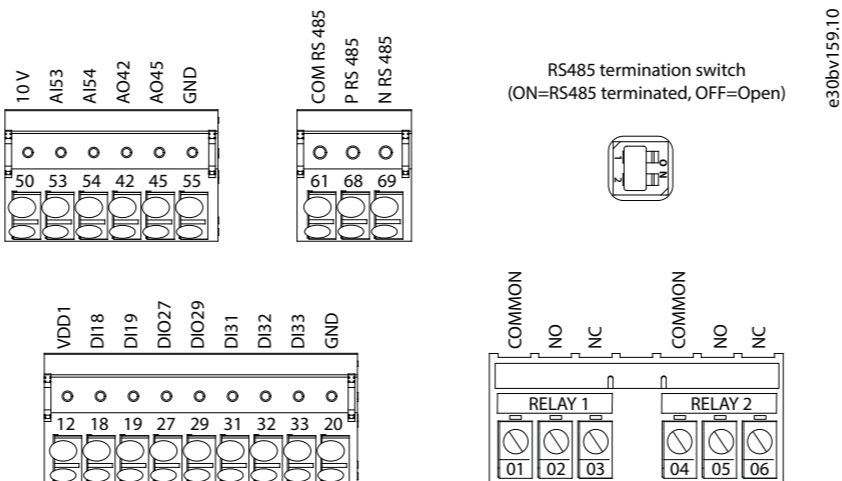

Illustration 4: Control Terminals

4 Specifications

Table 2: Electrical Data for Normal Overload, Mains Supply 3x380–480 V AC

Drive	Q110	Q132	Q160	Q200	Q250	Q315
Enclosure size	J8	J8	J8	J9	J9	J9
Normal overload=110% current during 60 s						
Typical shaft output at 400 V [kW]	110	132	160	200	250	315
Typical shaft output at 460 V [hp]	150	200	250	300	350	450
Output current (3-phase)						
Continuous (at 400 V) [A]	212	260	315	395	480	588
Intermittent (60 s overload) (at 400 V) [A]	233	286	347	435	528	647
Continuous (at 460 V) [A]	190	240	302	361	443	535
Intermittent (60 s overload) (at 460 V) [A]	209	264	332	397	487	589
Continuous kVA (at 400 V) [kVA]	147	180	218	274	333	407
Continuous kVA (at 460 V) [kVA]	151	191	241	288	353	426
Maximum input current						
Continuous (at 400 V) [A]	204	251	304	381	463	567
Continuous (at 460 V) [A]	183	231	291	348	427	516
Maximum number and size of cables per phase						
Mains and motor [mm ² (AWG)]	2x95 (2x3/0)			2x185 (2x350 mcm)		
Maximum external mains fuses [A]	315	350	400	550	630	800
Estimated power loss at 400 V [W]	2559	2954	3770	4116	5137	6674
Estimated power loss at 460 V [W]	2261	2724	3628	3569	4566	5714
Efficiency [%]	98					
Output frequency [Hz]	0–590					
Heat sink overtemperature trip [°C (°F)]	110 (230)					
Control card overtemperature trip [°C (°F)]	75 (167)			80 (176)		

Table 3: Electrical Data for High Overload, Mains Supply 3x380–480 V AC

Drive	H90K	H110	H132	H160	H200	H250
Enclosure size	J8	J8	J8	J9	J9	J9
High overload=150% current during 60 s						
Typical shaft output at 400 V [kW]	90	110	132	160	200	250
Typical shaft output at 460 V [hp]	125	150	200	250	300	350
Output current (3-phase)						
Continuous (at 400 V) [A]	177	212	260	315	395	480
Intermittent (60 s overload) (at 400 V) [A]	266	318	390	473	593	720
Continuous (at 460 V) [A]	160	190	240	302	361	443
Intermittent (60 s overload) (at 460 V) [A]	240	285	360	453	542	665
Continuous kVA (at 400 V) [kVA]	123	147	180	218	274	333
Continuous kVA (at 460 V) [kVA]	127	151	191	241	288	353
Maximum input current						
Continuous (at 400 V) [A]	171	204	251	304	381	463
Continuous (at 460 V) [A]	154	183	231	291	348	427
Maximum number and size of cables per phase						
Mains and motor [mm ² (AWG)]	2x95 (2x3/0)			2x185 (2x350 mcm)		
Maximum external mains fuses [A]	315	350	400	550	630	800
Estimated power loss at 400 V [W]	2031	2289	2923	3093	4039	5004
Estimated power loss at 460 V [W]	1828	2051	2089	2872	3575	4458
Efficiency [%]	98					
Output frequency [Hz]	0–590					
Heat sink overtemperature trip [°C (°F)]	110 (230)					
Control card overtemperature trip [°C (°F)]	75 (167)			80 (176)		

5 Ambient Conditions

J8–J9 enclosure size	IP20/Chassis
Vibration test (standard)	0.7 g
Relative humidity	5%–95% (IEC 721-3-3; Class 3K3 (non-condensing) during operation)
Aggressive environment (IEC 60068-2-43) H ₂ S test	Class Kd
Aggressive gases (IEC 60721-3-3)	Class 3C3
Test method according to IEC 60068-2-43	H ₂ S (10 days)

Ambient temperature (at SFAVM switching mode) - with derating - with full output power of typical EFF2 motors (up to 90% output current) - at full continuous FC output current	Maximum 55 °C (131 °F) Maximum 50 °C (122 °F) Maximum 45 °C (113 °F)
Minimum ambient temperature during full-scale operation	-15 °C (5 °F)
Minimum ambient temperature at reduced speed performance	-20 °C (-4 °F)
Temperature during storage/transport	-25 to +65/70 °C (-13 to +149/158 °F)
Maximum altitude above sea level without derating	1000 m (3281 ft)
Maximum altitude above sea level with derating	3000 m (9842 ft)
Energy efficiency class	IE2

6 Mounting Clearance

Enclosure size	Minimum mounting clearance [Maximum temperature 50 °C (122 °F)]
J8 and J9	Above and below: 225 mm (9 in)

7 EMC Compatibility and Motor Cable Length

EMC standard, Emission/Immunity	Category C3/EN/IEC 61800-3
Maximum motor cable length, shielded	Category C3/ 150 m (492 ft)
Maximum motor cable length, unshielded	300 m (984 ft)
Maximum cross-section to control terminals, rigid wire	1.5 mm ² /16 AWG (2x0.75 mm ²)
Maximum cross-section to control terminals, flexible cable	1 mm ² /18 AWG
Maximum cross-section to control terminals, cable with enclosed core	0.5 mm ² /20 AWG
Minimum cross-section to control terminals	0.25 mm ² /23 AWG

8 Programming

8.1 Local Control Panel (LCP)

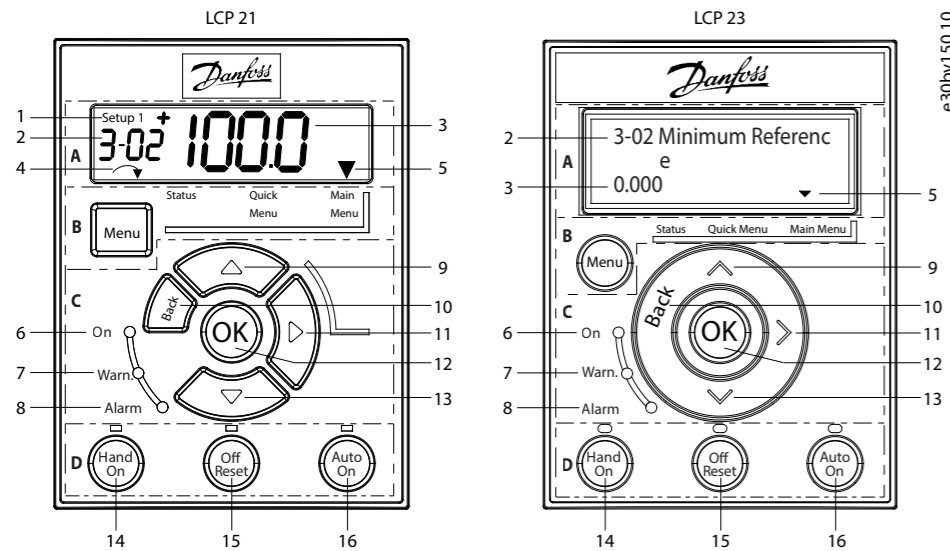

Illustration 5: Local Control Panel (LCP 21 and LCP 23)

Functional Section A: Display

Table 4: Display Function

Number	Function
1	The setup number shows the active setup and the edit setup. • For LCP 21: The setup number shows the active setup and the edit setup. If the same setup acts as both active and edit setup, only that setup number is shown (factory setting). • For LCP 23, the setup number shows on the upper right corner in the status mode. For example, "1(2)" means the active setup is "1" and the editing setup is "2".
2	• LCP 21 shows only parameter number. • LCP 23 shows both parameter number and name.
3	Parameter value.
4	Motor direction indicated by a small arrow pointing either clockwise or counterclockwise. For LCP 23, it only shows in status mode on the upper right corner of the screen.
5	The triangle indicates if the LCP is in Status, Quick Menu, or Main Menu.

Functional Section B: Menu Key

Press [Menu] to select among Status, Quick Menu, or Main Menu.

Functional Section C: Indicator Lights (LEDs) and Navigation Keys

Table 5: Indicator Lights (LEDs)

Number	Indicator	Light	Function
6	On	Green	Turns on when the drive receives power from the mains voltage, a DC bus terminal, or a 24 V external supply.
7	Warn.	Yellow	Turns on when warning conditions are met. Text is shown in the display area identifying the warning.
8	Alarm	Red	Flashes when a fault condition occurs. Text is shown in the display area identifying the alarm.

Table 6: Navigation Keys

Number	Key	Function
9/13	Up/Down	(1) Switches among parameter groups, parameters, and within parameters. (2) Increases or decreases parameter values. (3) Sets local reference.
10	[Back]	Moves to the previous step or layer in the navigation structure.
11	Right	Moves from left to right within the parameter value to change each digit individually.
12	[OK]	Selects a parameter and accepts changes to parameter settings.

Functional Section D: Operation Keys and Indicator Lights (LEDs)

Table 7: Operation Keys and Indicator Lights (LEDs)

Number	Key	Function
14	[Hand On]	(1) Starts the drive in local control. (2) An external stop signal via control input or serial communication overrides the local hand on command.
15	[Off/Reset]	(1) Stops the motor but does not remove power to the drive. (2) Resets the drive manually after a fault has been cleared. (3) In alarm mode, the alarm is reset when the alarm condition is removed.
16	[Auto On]	Puts the system in remote operational mode, in which the drive only respond to an external start command via control terminals or bus communication.

NOTICE

[2] Coast inverse is the default option for parameter 5-12 Terminal 27 Digital Input. If there is no 24 V supply to terminal 27, [Hand On] does not start the motor. Connect terminal 12 to terminal 27.

8.2 Automatic Motor Adaptation (AMA)

- Via running AMA in VVC+ mode, the drive builds a mathematical model of the motor to optimize compatibility between drive and motor, and thus enhances the motor control performance.
- Some motors may be unable to run the complete version of the test. In that case, select [2] Enable Reduced AMA in parameter 1-29 Automatic Motor Adaptation (AMA).
- For best results, run the following procedure on a cold motor.

Procedure:

1. Set motor data in parameter group 1-** Load and Motor according to the motor nameplate.
2. Connect terminal 27 to terminal 12 (24 V voltage) or choose [0] No operation in parameter 5-12 Terminal 27 Digital Input.
3. Set [1] Enable Complete AMA or [2] Enable Reduced AMA for parameter 1-29 Automatic Motor Adaptation (AMA).
4. Press the [Hand On] key, the test runs automatically and the main display indicates when it is completed.

9 Troubleshooting

Table 8: Warning and Alarm Code List

Number	Description	Warning	Alarm	Trip lock	Cause
2	Live zero error	X	X	-	Signal on terminal 53 or 54 is less than 50% of the values set in parameter 6-10 Terminal 53 Low Voltage, parameter 6-12 Terminal 53 Low Current, parameter 6-20 Terminal 54 Low Voltage, and parameter 6-22 Terminal 54 Low Current.
3	No motor	X	-	-	No motor has been connected to the output of the drive, or 1 motor phase is missing.
4	Mains phase loss ⁽¹⁾	X	X	X	Missing phase on the supply side, or the voltage imbalance is too high. Check the supply voltage.
7	DC overvoltage ⁽¹⁾	X	X	-	DC-link voltage exceeds the limit.
8	DC undervoltage ⁽¹⁾	X	X	-	DC-link voltage drops below the voltage warning low limit.
9	Inverter overloaded	X	X	-	More than 100% load for too long.
10	Motor ETR overtemperature	X	X	-	Motor is too hot due to more than 100% load for too long.
11	Motor thermistor overtemperature	X	X	-	Thermistor or thermistor connection is disconnected, or the motor is too hot.
12	Torque limit	X	X	-	Torque exceeds value set in either parameter 4-16 Torque Limit Motor Mode or parameter 4-17 Torque Limit Generator Mode.
13	Overcurrent	X	X	X	Inverter peak current limit is exceeded. For J1-J6 units, if this alarm occurs on power-up, check whether power cables are mistakenly connected to the motor terminals.
14	Ground fault	-	X	X	Discharge from output phases to ground.
16	Short circuit	-	X	X	Short circuit in motor or on motor terminals. For J7 units, if this alarm occurs on power-up, check whether power cables are mistakenly connected to the motor terminals.
17	Control word timeout	X	X	-	No communication to the drive.
18	Start failed	-	X	-	-
25	Brake resistor short-circuited	-	X	X	Brake resistor is short-circuited, thus the brake function is disconnected.
26	Brake overload	X	X	-	The power transmitted to the brake resistor over the last 120 s exceeds the limit. Possible corrections: Decrease brake energy via lower speed or longer ramp time.
27	Brake IGBT/Brake chopper short-circuited	-	X	X	Brake transistor is short-circuited, thus brake function is disconnected.
28	Brake check	-	X	-	Brake resistor is not connected/working.
30	U phase loss	-	X	X	Motor phase U is missing. Check the phase.
31	V phase loss	-	X	X	Motor phase V is missing. Check the phase.
32	W phase loss	-	X	X	Motor phase W is missing. Check the phase.
34	Fieldbus fault	X	X	-	PROFIBUS communication issues have occurred.

Number	Description	Warning	Alarm	Trip lock	Cause
35	Option fault	-	X	-	Fieldbus or option B detects internal faults.
36	Mains failure	X	X	-	This warning/alarm is only active if the supply voltage to the drive is lost and parameter 14-10 Mains Failure is NOT set to [0] No Function.
38	Internal fault	-	X	X	Contact the local supplier.
40	Overload T27	X	-	-	Check the load connected to terminal 27 or remove short-circuit connection.
41	Overload T29	X	-	-	Check the load connected to terminal 29 or remove short-circuit connection.
46	Gate drive voltage fault	-	X	X	-
47	24 V supply low	X	X	X	24 V DC may be overloaded.
50	AMA calibration	-	X	-	-
51	AMA check U _{nom} and I _{nom}	-	X	-	Wrong setting for motor voltage and/or motor current.
52	AMA low I _{nom}	-	X	-	Motor current is too low. Check the settings.
53	AMA big motor	-	X	-	The power size of the motor is too large for the AMA to operate.
54	AMA small motor	-	X	-	The power size of the motor is too small for the AMA to operate.
55	AMA parameter range	-	X	-	The parameter values of the motor are outside of the acceptable range. AMA does not run.
56	AMA interrupt	-	X	-	The AMA is interrupted.
57	AMA timeout	-	X	-	-
58	AMA internal	-	X	-	Contact the local supplier.
59	Current limit	X	X	-	The drive is overloaded.
60	External Interlock	-	X	-	-
61	Encoder loss	X	X	-	-
63	Mechanical brake low	-	X	-	Actual motor current has not exceeded release brake current within start delay time window.
65	Control card temp	X	X	X	The cutout temperature of the control card is 80 °C (176 °F).
67	Option module configuration has changed	-	X	-	One or more options have either been added or removed since the last power-down.
69	Power card temp	X	X	X	-
70	Illegal FC config	-	X	X	-
80	Drive initialized to default value	-	X	-	All parameter settings are initialized to default settings.
87	Auto DC brake	X	-	-	Occurs in IT mains when the drive coasts and the DC voltage is higher than 830 V. Energy on DC-link is consumed by the motor. This function can be enabled/disabled in parameter 0-07 Auto DC Braking.
88	Option detection	-	X	-	A change in the option layout is detected. Parameter 14-89 Option Detection is set to [0] Frozen configuration and the option layout has been changed. • To apply the change, enable option layout changes in parameter 14-89 Option Detection. • Alternatively, restore the correct option configuration.
90	Feedback monitor	X	X	-	A feedback fault is detected by option B.
95	Broken belt	X	X	-	-
99	Locked rotor	-	X	-	-
101	Flow/pressure information missing	-	X	X	-
120	Position control fault	-	X	-	-
124	Tension limit	-	X	-	-
126	Motor rotating	-	X	-	-
127	Back EMF too high	X	-	-	Try to start PM motor which is rotating in an abnormal high speed.
250	New spare part	-	X	X	-
251	New type code	-	X	X	-

Note:

- (1) These faults may be caused by mains distortions. Installing a Danfoss line filter may rectify this problem.
- (2) An (X) marked in the above table indicates that the warning or alarm has occurred. A warning precedes an alarm.

10 Accessories and Spare Parts

Accessories and spare parts		Code number	Accessories and spare parts		Code number
(1)	VLT® PROFIBUS DP MCA 101	134B6778	(6)	VLT® graphical control panel LCP 23	132B0801
(2)	VLT® PROFINET MCA 120	134B6779	(7)	VLT® numeric control panel LCP 21	132B0254
(3)	VLT® encoder input MCB 102	132B0282	(8)	Remote mounting kit for LCP with cable, 3 m	132B0102
(4)	VLT® resolver input MCB 103	132B0283	(9)	LCP remote mounting cable, 3 m	132B0132
(5)	VLT® 24 V DC supply MCB 107	130B1208	(10)	Control card for FC 360 J8-J9	132G0279

Note: (1) - (9) are accessories, and (10) is spare part. For more spare parts, contact Danfoss.

11 Technical Documentation

Scan the QR code to access more technical documents for the drive. Or, after scanning the QR code, click **Global English** on the website to select your local region's website, search **FC 360** to find the documents with your own languages.



Danfoss A/S
Ulsnaes 1
DK-6300 Graasten
drives.danfoss.com

Danfoss can accept no responsibility for possible errors in catalogs, brochures, and other printed material. Danfoss reserves the right to alter its products without notice. This also applies to products already on order provided that such alterations can be made without consequential changes being necessary in specifications already agreed. All trademarks in this material are property of the respective companies. Danfoss and the Danfoss logotype are trademarks of Danfoss A/S. All rights reserved.