

Operating Guide

AME 13 SU/SD-1

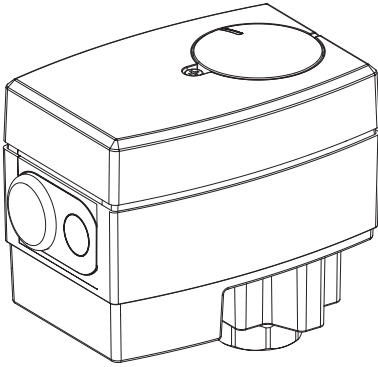

Stem Travel	5,5 mm
Travel Speed	11,7 (14) s/mm

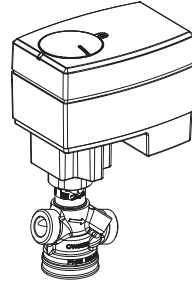

AME 13 SD-1 +
AB-QM

Washer	003Z0257
--------	----------

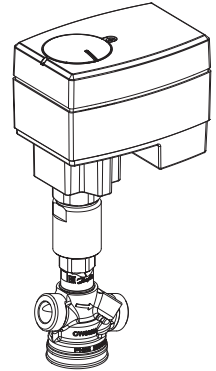

AME 13 SU-1 +
AB-QM

Adapter	003Z3960
---------	----------

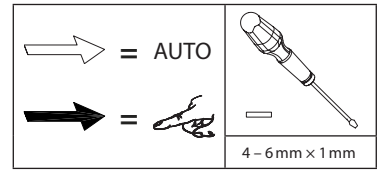

1

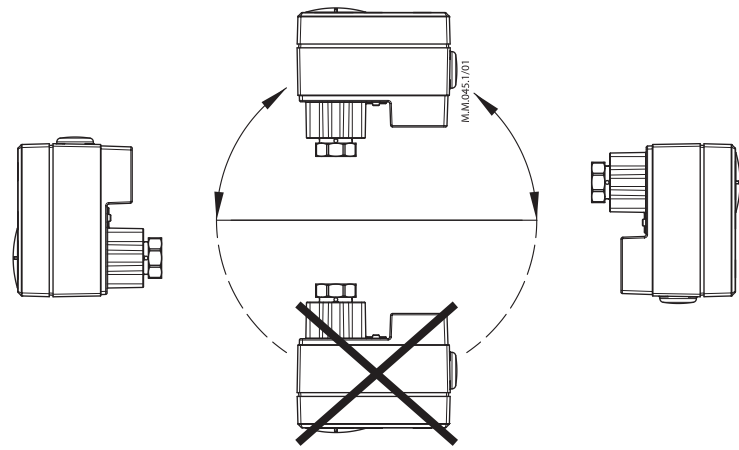

2



Do not use as ON/Off actuator.

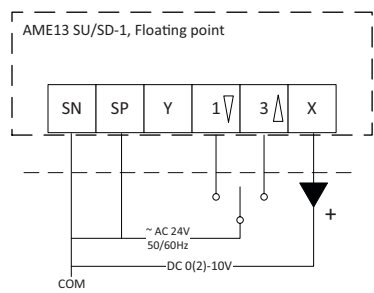
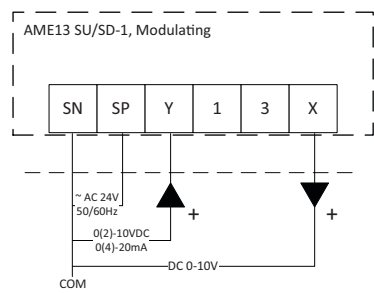

AME 13 SU/SD-1

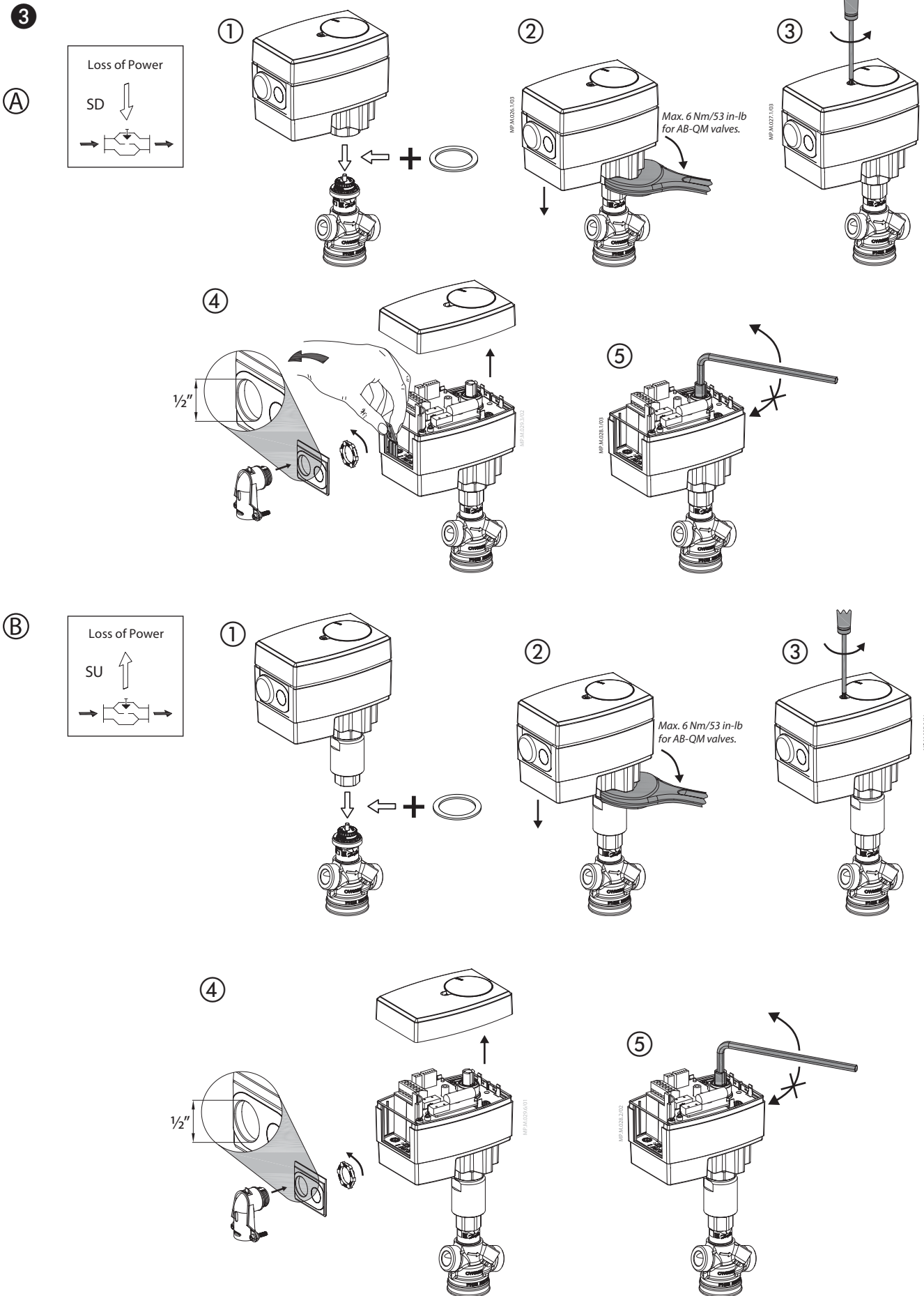

AME 13 SU/SD-1

4

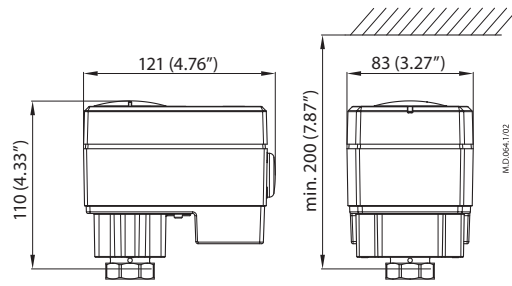

5

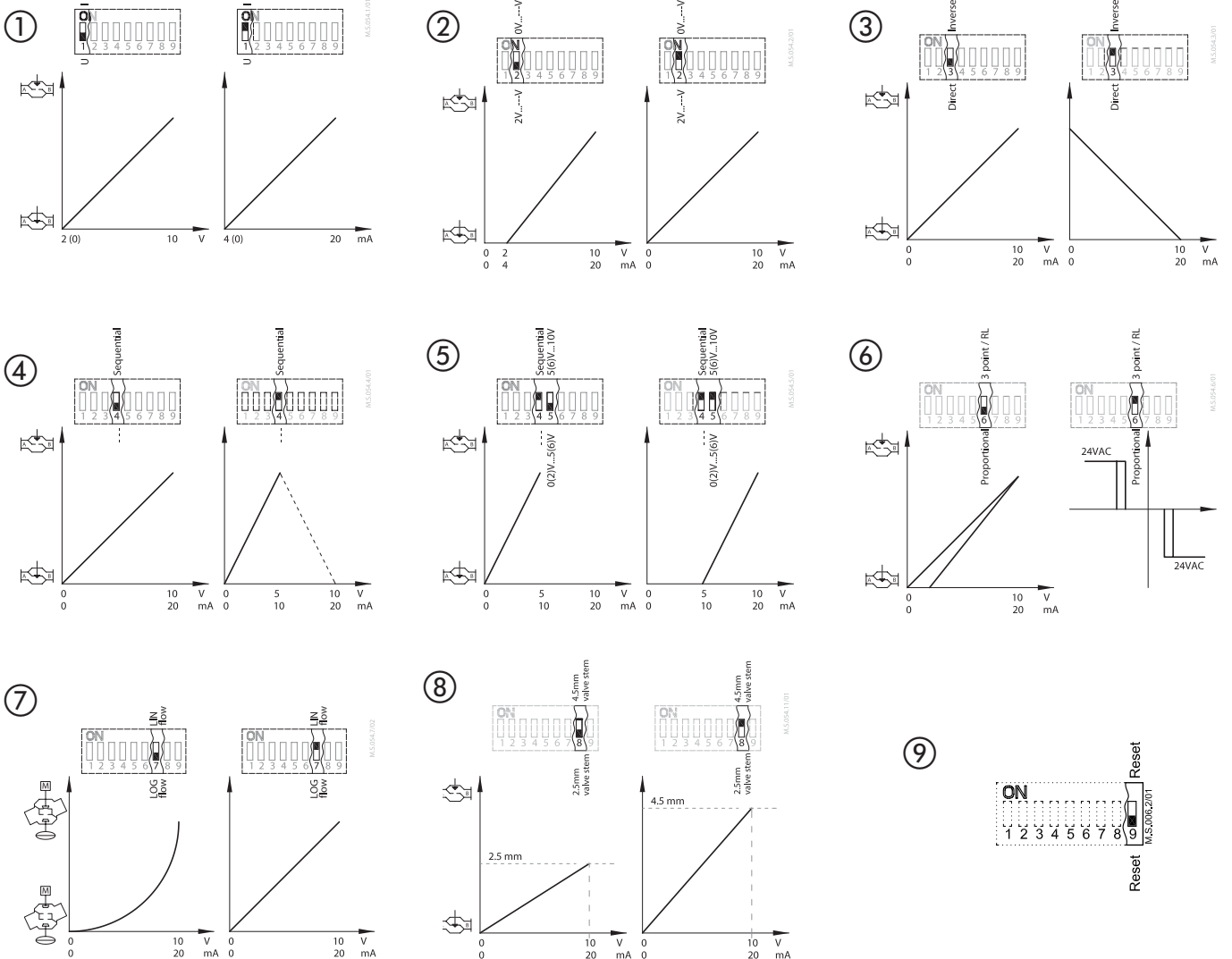
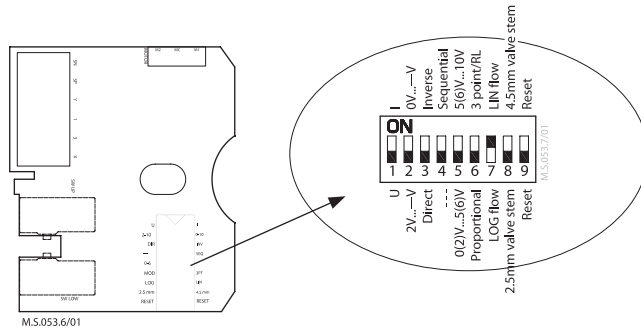

AME 13 SU/SD-1

ENGLISH

Safety Note



To avoid personal injury and damage to the device or other property, it is necessary to read and follow these instructions carefully.

Assembly, start-up, and maintenance work must be performed by qualified and authorized personnel.

Comply with the instructions of the system manufacturer or system operator.



Do not remove the cover before the power supply is fully switched off.

Mounting Position ①

The actuator should be mounted with the valve stem in either a horizontal position or pointing upwards.

Wiring ②



AC 24 V
Connect via Class 2 (North America) or Safety Extra-Low Voltage (SELV) (Europe). Failure to comply can lead to equipment damage or personal injury.



Switch off power before wiring the actuator!

1. Make all wiring connections in accordance with local, national, or regional regulations.
2. For applications requiring conduit, a field supplied 1/2" trade size electrician's fitting and lock nut can be mounted in the actuator enclosure. Use flexible metallic tubing or its equivalent with the field supplied fitting.
3. Insert wiring material through the removable plug or conduit fitting, and connect to the terminal block using the applicable wiring diagram ②.

Installation ③

1. Depending on the version of actuator (SU/SD) prior to installation an included washer and adapter is required to be installed: SD, Washer (**003Z0257**)
The washer is placed on the valve neck prior to the installation of the actuator.
SU, Adapter (**003Z3960**) and washer (**003Z0257**)
Hand tighten the adapter to the neck of the valve. The actuator will be installed to the adapter.
2. The actuator should be in the full up position ① (factory setting). If it is not, refer to the manual override instructions ③④.
3. The actuator is fixed to the valve body or adapter by means of a union nut which requires an adjustable wrench to assist in tightening the actuator to the valve.

Danfoss A/S

Climate Solutions • danfoss.com • +45 7488 2222

DIP switch settings ⑤

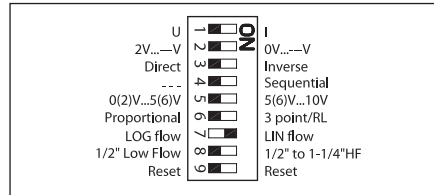

Factory settings:

ALL switches are on OFF position!
(except SW7 which is in ON position)!

NOTE:

All combinations of DIP switches are allowed.
All functions that are selected are added consecutively. There is only one logic override of functionalities i.e. the switch No.6 Proportional /3 point, which sets actuator to ignore control signal and works as a "simple" 3-point actuator.

SW 1: VDC / mA - Input signal type selector ①

If set to OFF position, voltage input is selected. If set to ON position, current input is selected.

SW 2: 0/2 - Input signal range selector ②

If set to OFF position, the input signal is in the range from 2-10 V (voltage input) or from 4-20 mA (current input). If set to ON position, the input signal is in the range from 0-10 V (voltage input) or from 0-20 mA (current input).

SW3: D/I - Direct or inverse acting selector ③

If set to OFF position, the actuator is direct acting (stem retracts as voltage increases). If the actuator is set to ON position, the actuator is inverse acting (stem extends as voltage increases).

SW4:---/Seq - Normal or sequential mode selector ④

If set to OFF position, the actuator is working normally in 0(2)-10V or 0(4)-20mA range. If set to ON position, the actuator is working in a sequential mode with its range dependent on the position of SW 4.

SW5: 0-5 V/5-10 V - Input signal range in sequential mode ⑤

If set to OFF position, the actuator is working in sequential range 0(2)-5 (6) V or 0(4)-10 (12) mA. If set to ON position, the actuator is working in sequential range; 5(6)-10 V or 10(12)-20 mA

SW6: Proportional/Floating point ⑥

If set to ON position, the actuator can operate as Floating point actuator. Power supply should be connected on SN and SP ports. On port 1 or 3 24 VAC signal is connected for rising or lowering of actuator. Return signal X indicates the correct position.

If set to OFF position, the actuator operates on modulating input signal.



NOTE:

if 3 point function is selected actuator does not respond to any control signal on port Y. It only rises and lowers spindle if power is supplied on port 1 or 3.

SW7: LIN/LOG - Linear or equal percentage flow through valve selector ⑦

If set to ON position, the flow through the valve is linear to the control signal.

If set to OFF position, the valve position is equal percentage acc. to the control signal.

Note:

It is generally recommended to configure the AME 13 actuator for operation in linear mode (SW7 set to ON).

SW8: ⑧

Set to ON for valve bodies 1/2" to 1-1/4" HF. The actuator will modulate on max stem travel of 4.5mm.

Set to OFF for valve body 1/2" Low flow. The actuator will modulate on max stem travel of 2.5mm.

SW9: Reset ⑨

Toggleing the switch will cause the actuator to go through an auto-calibration cycle.

Function test

The indicator light shows whether the positioner is in operation or not. Moreover, the indicator shows the control status and faults.

Constant light

- normal operation

No light

- no operation or no power supply

Intermittent light (1 Hz)

- self adjusting-mode

Intermittent light (3 Hz):

- power supply too low
- insufficient valve stroke (<20 s)
- end-position cannot be reached.

The following information is provided on the device or on the instruction manual or datasheet:

- A) Purpose of control: Electrical Actuator
- B) Construction of control: Independently Mounted Control
- C) Method of mounting control
- D) Type 1 Action
- E) Pollution Degree 3
- F) Impulse Voltage: 500V
- G) Software Class A
- H) Mechanical and thermal ratings (ref to Ratings section for more details)
- I) "Use 1/2 inch flexible metal conduit for connection"
- J) "Use Listed Flexible Metal Conduit Fitting DWTT/7"
- K) "Use 60°C/75°C copper (CU) conductor and wire size range (#) AWG, stranded or solid".
"The terminal tightening torque of (#) Lb per In."
- L) Torque value for Cover screw: 0,6 +/-0,1 Nm.

Note (#): Values depend by field wiring ratings of terminal block employed on the device construction.

Any information, including, but not limited to information on selection of product, its application or use, product design, weight, dimensions, capacity or any other technical data in product manuals, catalogues descriptions, advertisements, etc. and whether made available in writing, orally, electronically, online or via download, shall be considered informative, and is only binding if and to the extent, explicit reference is made in a quotation or order confirmation. Danfoss cannot accept any responsibility for possible errors in catalogues, brochures, videos and other material. Danfoss reserves the right to alter its products without notice. This also applies to products ordered but not delivered provided that such alterations can be made without changes to form, fit or function of the product.

All trademarks in this material are property of Danfoss A/S or Danfoss group companies. Danfoss and the Danfoss logo are trademarks of Danfoss A/S. All rights reserved.