

Data sheet

# Electric 3-way valve

## Type CTR 20



The CTR is an electrically operated 3-way valve designed specifically for operation in CO<sub>2</sub> systems with heat reclaim. CTR is designed to allow full proportional control of the surplus heat from compressor pack into the heat exchanger of transcritical heat reclaim solutions.

The proportional control of the CTR ensures that the exact amount of heat required is available at any time, and the possibility to operate smoothly in changeover situations allowing for stable control.

The typical application for the CTR is a Pack/rack system in food retail application working with transcritical CO<sub>2</sub>. Heat reclaim is the current most attractive energy advantage of transcritical CO<sub>2</sub>. Even as transcritical CO<sub>2</sub> systems are on par or outperform traditional HFC installations on energy performance, this also ensures the possibility to supply high quality heat to be exploited. Heat reclaim is seeing an increased deployment and becoming a norm in most transcritical CO<sub>2</sub> retail installations today.

**Application:**

Heat reclaim in CO<sub>2</sub> systems (transcritical).

**Features**

- Full proportional and on / off control of the heat reclaim system.
- 2 inlets and 1 outlet or 1 inlet and 2 outlets.
- Applicable to R744 and other common refrigerants.
- CTR is compatible with oil types PAG and POE
- Full serviceable cartridge design valve.
- Modulating operation to ensure smooth transition.
- Leak tight, motor integrated in valve.
- Eliminates pressure peaks in heat reclaim systems.
- Controls transcritical pressure up to 140 bar.
- Available for combo weld or solder/braze.
- Standard M12 connector for easy connection to the motor driver.
- Internal / external corrosion resistant design.
- Manufactured according to ISO / TS 16943.



For more information on the product,  
please scan the QR code.

**Data sheet | Electric 3-way valve type CTR 20**

**Approvals**

EAC, UKCA, LLC CDC TYSK



**Technical data**

**Valve specification**

|  |  |
|--|--|
| Feature                                | CTR 20 (DN25)  |
| Flow                                   | 1 inlet -2 outlets or 2 inlets - 1 outlet                                    |
| Refrigerant                            | R744 (For other refrigerants please contact Danfoss)                         |
| Oil Types                              | PAG / POE  |
| MWP/ Refrigerant                       | 140 bar / 2030 psig  |
| MOPD                                   | 3 bar / 43 psi   |
| Allowed ambient temperature range      | -40 – +60 °C / -40 – +140 °F   |
| Allowed refrigerant temperature range  | 0 – +150 °C / +32 – +302 °F  |
| Environment temp (Transport/Warehouse) | -40 – +70 °C / -40 – +158 °F   |
| Lifetime / endurance                   | 10 years / 50.000 cycles in CO <sub>2</sub> system with 3 bar diff. pressure |
| Serviceable                            | Yes  |

**Electrical specification**

|                                  |  |
|----------------------------------|--|
| Stepper motor type               | Bipolar permanent motor  |
| IP rating of electric connection | 67   |
| Step mode                        | Microstepping (recommended), 2 phase full step   |
| Phase resistance                 | 52.4 ohm ±10% per coil   |
| Inductance                       | 85.7 mH ±20%   |
| Current per coil                 | 100 mA RMS / 142 mA Peak   |
| Holding current                  | 20% holding current (recommended)  |
| Duty cycle                       | 100% duty cycle is allowed   |
| Max. total power                 | Current driver: 1.2 Watt   |
| Number of full steps             | 6600   |
| Closing / opening time           | 88 sec @ 75 PPS  |
| Step rate                        | Current control ≤ 75 step /sec. (recommended)<br>75 PPS for top and bottom 10% opening / closing degree and remaining at 250 pps |
| Electric connector type          | M12  |
| Reference position               | Over drive against the full close position (both top & bottom)   |
| Overdriving in closing direction | Recommended 3% of total step ie. 180 full steps  |
| Recommended controller/driver    | AK-XM 208C, EKD 316, EKD 316C  |

|                                    |  |
|------------------------------------|--|
| Material of construction (Housing) | Stainless Steel                              |
| Installation orientation           | Vertical / Horizontal (Inverted not allowed) |
| Valve opening characteristic       | Linear                                       |

**Data sheet | Electric 3-way valve type CTR 20**

**Ordering**

Valve including actuator

| Type   | Connection                   |                      | Flow rate                                   |                               | Single pack | Code no  |
|--------|------------------------------|----------------------|---|-------------------------------|-------------|----------|
|        | Weld <sup>1)</sup><br>[inch] | Solder ODF<br>[inch] | k <sub>v</sub> value<br>[m <sup>3</sup> /h] | C <sub>v</sub> value<br>[gpm] |             |          |
| CTR 20 | 1                            | 1 1/8                | 20  | 23.1                          | 1           | 027H7244 |

<sup>1)</sup> OD according to EN 10220

**Spareparts**

| Type   | Description                                  | Single pack | Code no. |
|--------|--|-------------|----------|
| Gasket | O-ring spare part kit for CTR 20 (3 O-rings) | 1           | 027H7248 |

**Related products**

| Type       | Description                                   | Single pack | Code no. |
|------------|---|-------------|----------|
| AK-XM 208C | Stepper output module                         | 1           | 080Z0023 |
| EKD 316C   | Superheat controller / driver (preferred EKD) | 1           | 084B8045 |
| EKD 316    | Superheat controller / driver                 | 1           | 084B8040 |
| EKA 164A   | Optional display for EKD 316                  | 1           | 084B8563 |
| AST-G      | Manual service driver                         | 1           | 034G0013 |

**Identification, product label**

MADE IN DENMARK : Country of origin  
**CTR 20 DN25** : Valve type  
**027H7244** : Code number  
MOPD: 3,00 bar / 43.0 psi : Max. operation pressure  
PS 140,0 bar / MWP 2030 psig : Max. working pressure  
CE : Approval  
BR0417D/103320 : (Manufacturing no.)  
BR = Kolding  
04 = week  
17 = 2017  
D = Thursday



**Accessories:**

**M12 angle cable**

M12 angle female connector is intended for use with a standard M12 male connector, available on stepper motor valves.

This cable is designed to offer high flexibility and small outer diameters with tensile strength. The angle way M12 cable consist of paired, twisted wires, which decreases mutual influence between signals transmitted along the cable and reduces influence of external sources of interference. The cables thus provides a higher degree of protection against lost steps compared to other cables.

**Approvals**



**Specification**

|                             |  |
|-----------------------------|--|
| Jacket                      | PVC - black  |
| Cable outer sheath          | Oil resistant  |
| Water proof rating          | IP 67  |
| Operating temperature range | -40 – +80 °C / -40 - +176 °F                             |
| Wire type                   | Twisted pair, cross section 20 AWG / 0.5 mm <sup>2</sup> |
| Cable outer diameter        | 7.0 mm / 0.28 inch                                       |
| Minimum bending radius      | 10 x cable diameter                                      |
| Cable combustibility / test | Flame retardant / VW-1 / CSA FT - 1                      |
| M12 standard                | EN 61076-2-101   |
| Reference standard          | UL style 2464 and DIN VDE 0812                           |
| LVD directive               | 73/23/EEC and 93/68/EEC                                  |

**Ordering**

| Cable       | Cable length (L) | Insulation | Packing format | Code no.        |
|-------------|------------------|------------|----------------|-----------------|
| PVC - black | 2 m / 6.6 ft     | SR-PVC     | Single pack    | <b>034G7073</b> |
|             | 8 m / 26.2 ft    | SR-PVC     | Single pack    | <b>034G7074</b> |

**Identification**

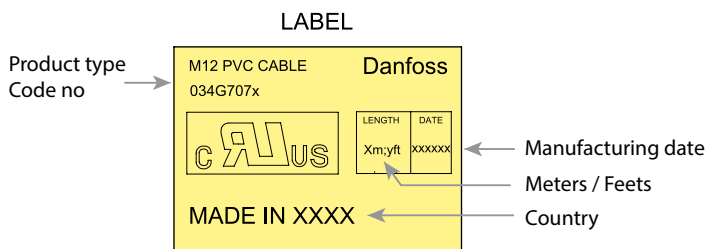

**Connections**



**Dimensions**

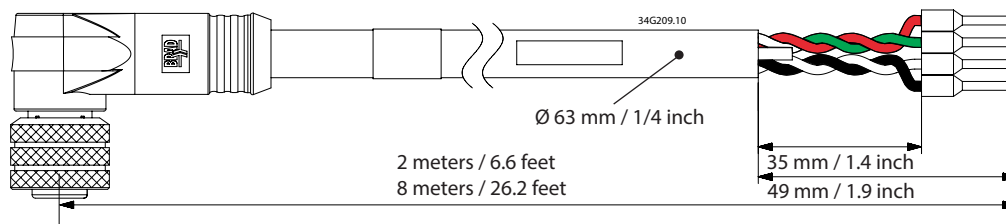

Valve design

- 1. M12 connector
- 2. Actuator
- 3. Spindle
- 4. Valve housing
- 5. Connection 1
- 6. Connection 3
- 7. Connection 2
- 8. Valve cone

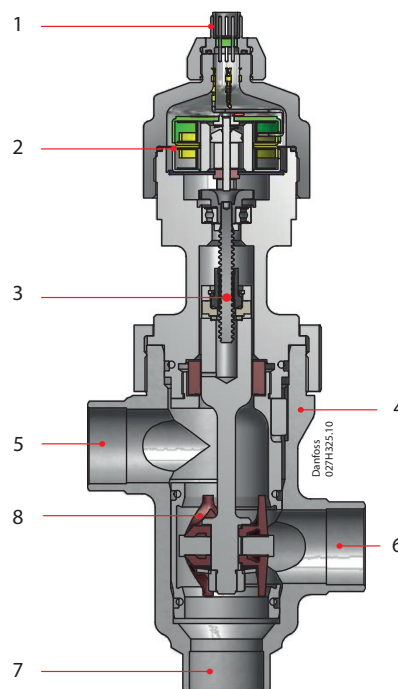

Flow direction

CTR Valve can be used in following ways as shown in the drawings.

1 inlet 2 outlets  
Connection 3 is always common inlet

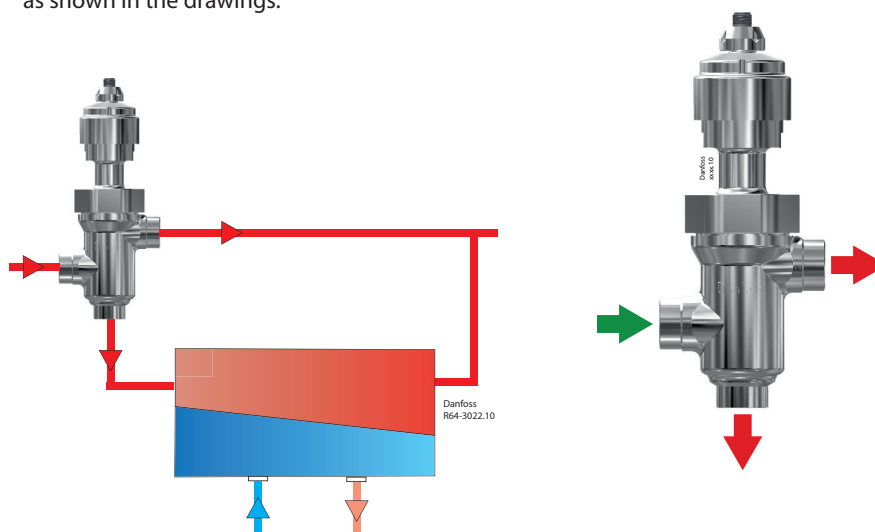

2 inlets 1 outlet  
Connection 3 is always common outlet

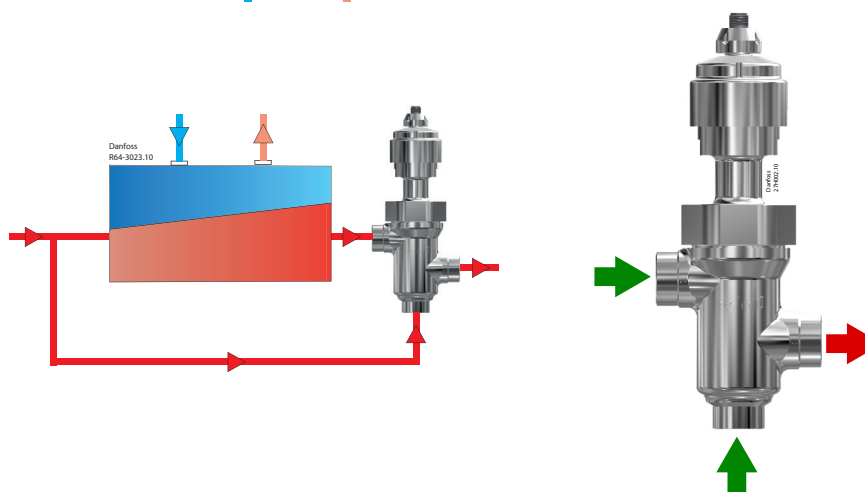



### Coolselector<sup>®</sup>2

is a Danfoss calculation and selection software, designed to make selection processes for all refrigeration projects easier and less time consuming.

For fast and precise selection of valve, use Danfoss' CoolSelector2<sup>®</sup> software.

You can download it from <http://coolselector.danfoss.com>

### Application example

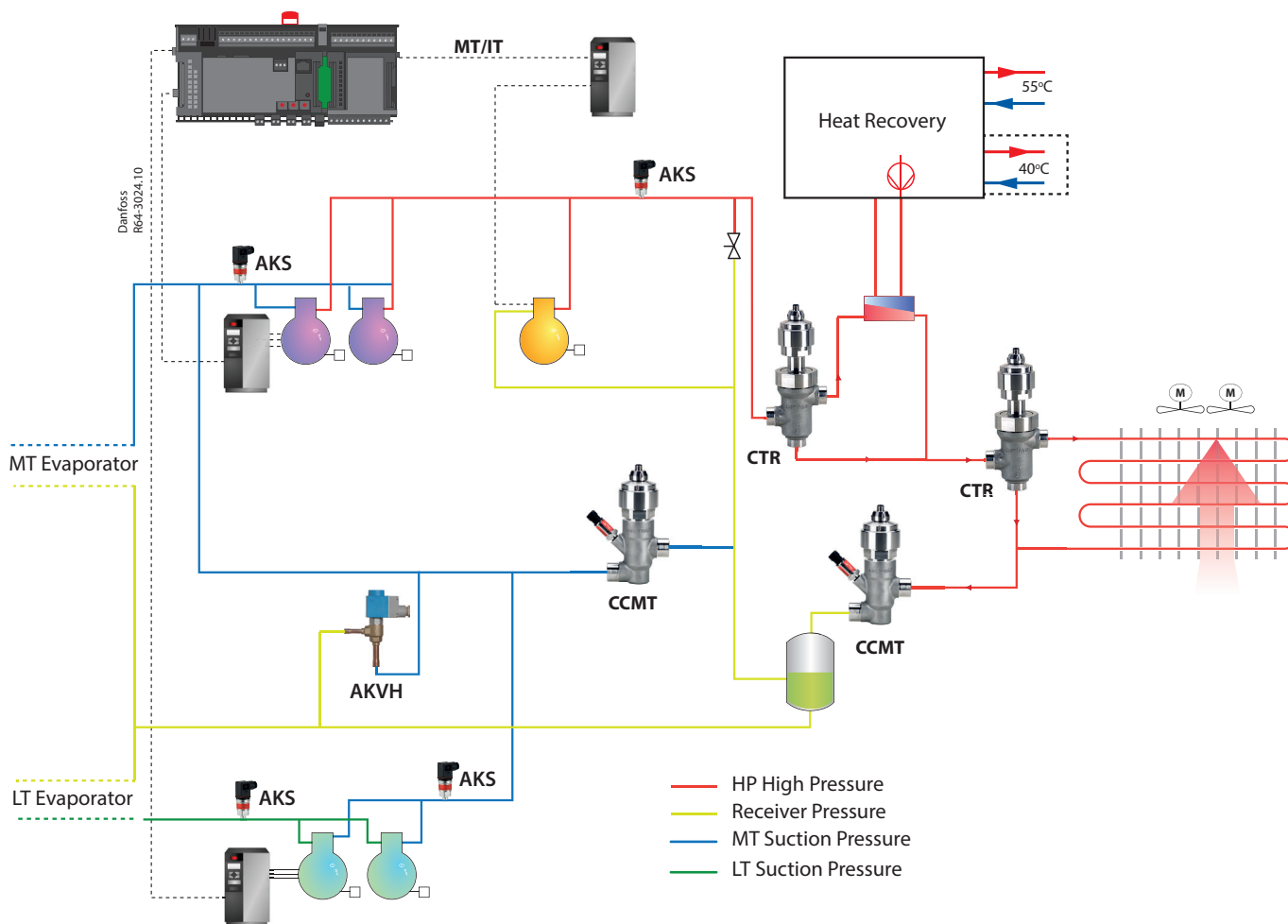

In CO<sub>2</sub> systems, the higher pressure and temperature make it possible to recover heat for tap water and heating. The excess heat is removed using a gas cooler. Regulation is carried out during transcritical and subcritical states and the controller will control the gas pressure/condensing pressure so that the system achieves the optimum COP when the recovered heat is taken into account. The regulation of the heat recovery circuits is done with regard to the cooling system. In the event of conflict, the safety situation is that the cooling system has higher priority than the recovery circuits.

The two heat recovery circuits can be considered as independent circuits - also with regard to the cooling system. First, the circuit for hot tap water will take the energy it needs to use. The remaining energy is then available for use by the next circuit. This also takes what is available. If there is then any excess energy, this is removed via the gas cooler. There must be a cooling requirement in order to supply for heat recovery.

Application example

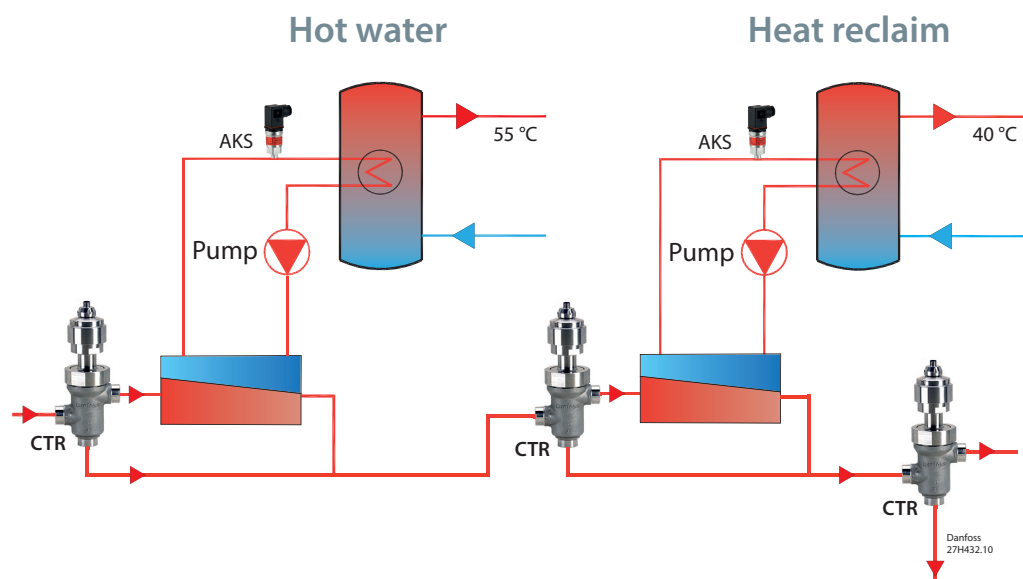

CTR Valve provides Modulating operation to ensure smooth transition avoiding too many Compressor on/off when going from Heat reclaim mode to full through Gas Cooler.

In the above example, the 3-way valve switches to enable flow of hot gas to enter heat reclaim heat exchanger. Here heat is transitioned to the water loop hence the Hot Gas is cooled. On the diagram, first heat is used for Hot Tap water and then with a second 3-way valve heat used for

the heating loop for the building, finally a third 3-way valve is mounted to enable by-pass of the gas cooler if that is needed. E.g. in a very cold season, where the pressure would drop too much after recovering all the heat in the plate heat exchangers.

**Warning**

If the pressure drop in the heat exchanger and connecting pipes are less than 3 bar, the valve can be installed in any way the users likes based on the application. However, if there for some reason is a larger pressure drop than the MOPD of the valve then the right connection of the valve, as shown on the following diagram, is important for safety reasons.

If the connections is done as shown in the diagram, then the valve will always be able to go out of heat recovery mode and will always be able to let the gas cooler into operation no matter what pressure drop is in the heat exchanger and piping. Therefore, Danfoss advises that the valve is always installed according to the diagram.

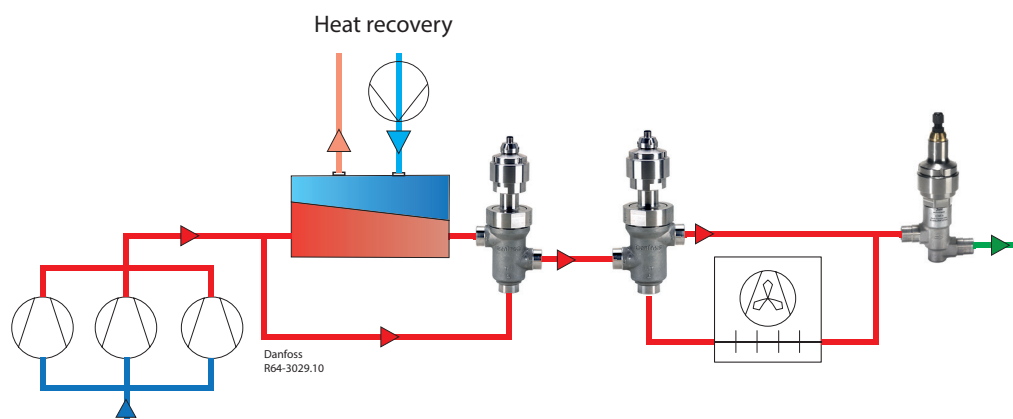

Flow characteristics

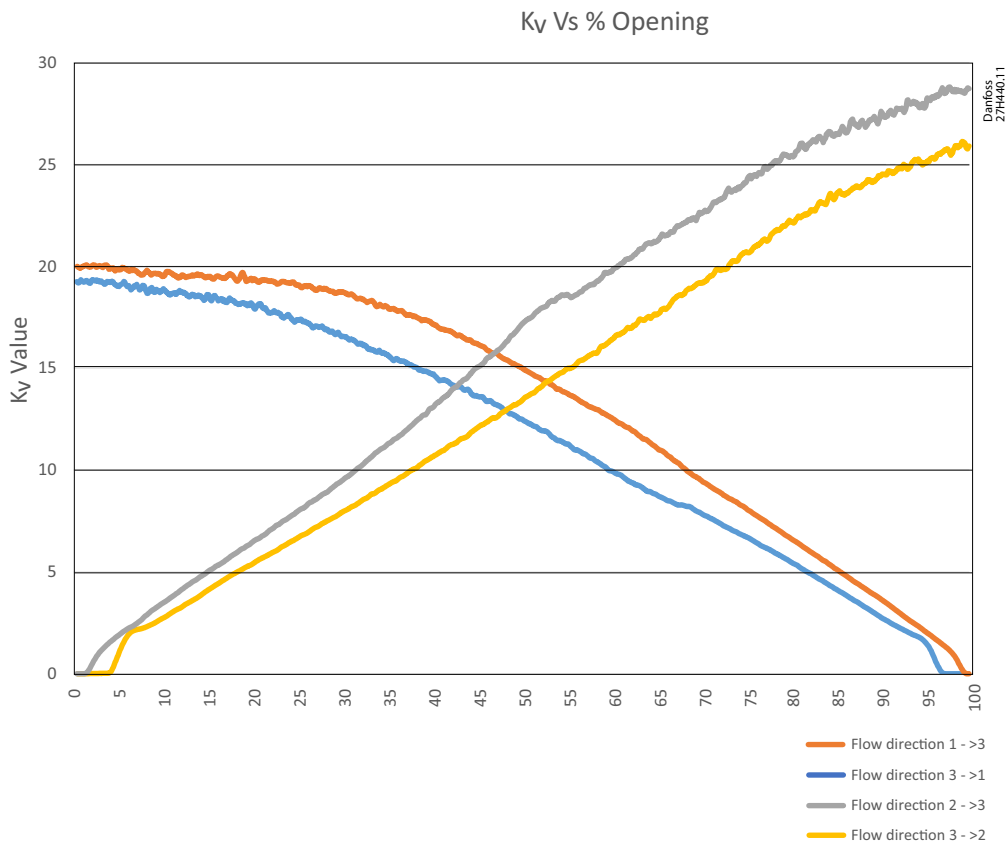

Driving CTR valve

CTR valve uses a bipolar, 2-phase, permanent magnet stepper motor. CTR valve can be driven using various electronic control techniques i.e.: Full step excitation mode, half step excitation mode, micro stepping mode (recommended). On selecting controller from other manufacturer than Danfoss, it is necessary to set the correct valve data into the controller setting. The wrong settings may impair the performance of the valve.

- Total no. of step
- Step rate
- Phase current
- Overdriving against closing position



Note:

If the controller driving the CTR valve is from another manufacturer than Danfoss or a custom design, the following points must be considered in order to overcome potential step loss. To ensure total closing of the valve, and to compensate the lost steps after a defined number of changes in opening degree, the controller should have a function to overdrive the valve in the closing direction. It is recommended to overdrive the valve at appropriate intervals.

Cable length

Depending on the type of controller or driver, there will be limitations in cable length between the controller / driver and the valve. Both the actual cable length, the level of EMC emission on the location and the driver circuit have an impact on the actual distortion of the current to the motor.



Warning

At power failure the CTR valve will remain in the actual opening position it has at the moment of power failure, unless a device in the form of a battery backup to the controller is installed.

Stepper motor switch sequence

The following table shows the full step excitation switching sequence

|              | STEP | Coil I (B) |       | Coil II (A) |       |              |
|--------------|------|------------|-------|-------------|-------|--------------|
|              |      | Red        | Green | White       | Black |              |
| CLOSING<br>↑ | 1    | +          | -     | +           | -     | ↓<br>OPENING |
|              | 2    | +          | -     | -           | +     |              |
|              | 3    | -          | +     | -           | +     |              |
|              | 4    | -          | +     | +           | -     |              |
| 1            | +    | -          | +     | -           |       |              |

Color code is only valid for Danfoss M12 cable

Danfoss cable connections

| Pin | Wire color |
|-----|------------|
| A1  | White      |
| A2  | Black      |
| B1  | Red        |
| B2  | Green      |

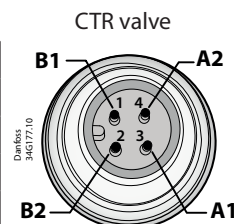



### Dimensions and weight

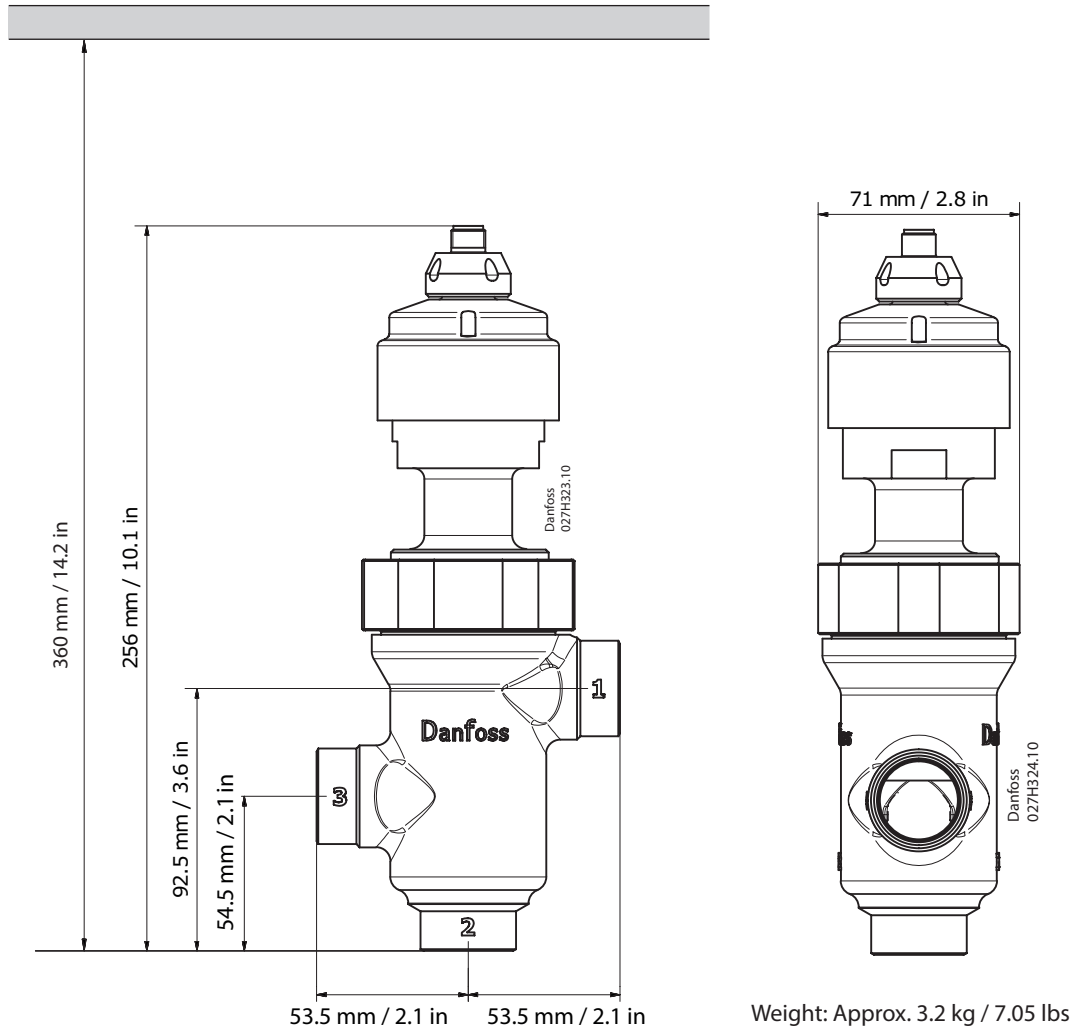

### Related products

|   |   |  |  |
|---|---|--|--|
|   |   |  |  |
| <p>Electronic driver, type EKD 316 / EKD 316C</p> | <p>Electronic controller, type EKC 326a and EKC 313</p> | <p>Electronic driver type AK-XM 208C</p> | <p>AKS 11 / AKS 12 temperature sensor<br/>AKS pressure transmitter</p> |

Danfoss can accept no responsibility for possible errors in catalogues, brochures and other printed material. Danfoss reserves the right to alter its products without notice. This also applies to products already on order provided that such alterations can be made without consequential changes being necessary in specifications already agreed. All trademarks in this material are property of the respective companies. Danfoss and the Danfoss logotype are trademarks of Danfoss A/S. All rights reserved.