



# iC2-Micro Frequency Converters

130R1215

## 1 Introduction

This operating guide provides necessary information for qualified personnel to install and commission the AC drive. Read and follow the instructions to use the drive safely and professionally.

**Do not dispose of equipment containing electrical components together with domestic waste. Collect it separately in accordance with local and currently valid legislation.**

## 2 Safety

Pay particular attention to the safety instructions and general warnings to avoid the risk of death, serious injury, and equipment or property damage.

### WARNING

#### HIGH VOLTAGE

AC drives contain high voltage when connected to AC mains input, DC supply, or load sharing.

#### UNINTENDED START

The motor may start from control panel, I/O inputs, fieldbus, or MyDrive® Insight at any time, when the drive is connected to the AC mains, DC supply, or load sharing.

#### DISCHARGE TIME

The drive contains DC-link capacitors, which can remain charged even when the drive is not powered. High voltage can be present even when the warning indicator lights are off.

- Stop the motor, disconnect AC mains and permanent magnet type motors, and remove DC-link supplies, including battery backups, UPS, and DC-link connections to other drives.

- Wait for the capacitors to discharge fully and measure it before performing any service or repair work.

- The minimum waiting time is 4 minutes for MA01c, MA02c, MA01a, MA02a, and MA03a drives, and 15 minutes for MA04a and MA05a drives.

#### LEAKAGE CURRENT

Leakage currents of the drive exceed 3.5 mA. Make sure that the minimum size of the ground conductor complies with the local safety regulations for high touch current equipment.

## 3 Installation

### 3.1 Mechanical Dimensions

Enclosure size	Height [mm (in)]		Width [mm (in)]		Depth [mm (in)] <sup>(2)</sup>	Mounting holes [mm (in)]	
	A	A <sup>(1)</sup>	B	b			
MA01c	150 (5.9)	216 (8.5)	140.4 (5.5)	70 (2.8)	55 (2.2)	143 (5.6)	4.5 (0.18)
MA02c	176 (6.9)	232.2 (9.1)	150.5 (5.9)	75 (3.0)	59 (2.3)	157 (6.2)	4.5 (0.18)
MA01a	150 (5.9)	202.5 (8.0)	140.4 (5.5)	70 (2.8)	55 (2.2)	158 (6.2)	4.5 (0.18)
MA02a	186 (7.3)	240 (9.4)	176.4 (6.9)	75 (3.0)	59 (2.3)	175 (6.9)	4.5 (0.18)
MA03a	238.5 (9.4)	291 (11.5)	226 (8.9)	90 (3.5)	69 (2.7)	200 (7.9)	5.5 (0.22)
MA04a	292 (11.5)	365.5 (14.4)	272.4 (10.7)	125 (4.9)	97 (3.8)	244.5 (9.6)	7.0 (0.28)
MA05a	335 (13.2)	396.5 (15.6)	315 (12.4)	165 (6.5)	140 (5.5)	248 (9.8)	7.0 (0.28)

Note: (1) Including decoupling plate. (2) The potentiometer on the local control panel extends 6.5 mm (0.26 in) from the drive.

### 3.2 Mounting Clearance

Table 1: Minimum Mounting Clearance

Enclosure size	Minimum mounting clearance [maximum temperature 50 °C (122 °F)]
All enclosure sizes	Above and below: 100 mm (3.9 in).
MA01a–MA05a, MA02c	Sides: 0 mm (0 in).
MA01c (natural cooling)	Sides: 0 mm (0 in) for 40 °C (104 °F), 10 mm (0.39 in) and above for 50 °C (122 °F).

### 3.3 Connecting to Mains and Motor

- Mount the ground wires to the PE terminal.
- Connect motor to terminals U, V, and W.
- Mount mains supply to terminals L1/L, L2, and L3/N (3-phase) or L1/L and L3/N (single-phase) and tighten.
- For required maximum screwing torque, see the back of the terminal cover.

### 3.4 Load Sharing/Brake

Table 2: Connect Terminals

Load sharing	-UDC and +UDC/+BR
Brake	-BR and +UDC/+BR

- For MA01a, MA02a, and MA03a drives, wire with recommended connector (Ultra-Pod Fully Insulated FASTON Receptacles and Tabs, 521366-2, TE connectivity).
- For other enclosure sizes, mount the wires to the related terminal and tighten. For required maximum screwing torque, see the back of the terminal cover.
- For more details, contact Danfoss or refer to the drive's design guide.

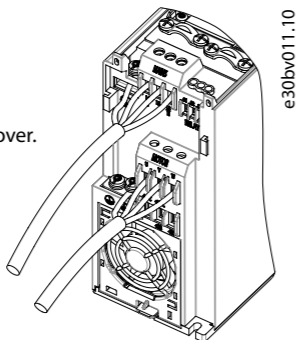

Illustration 1: Mounting of Ground Cable, Mains, and Motor Wires

### NOTICE

Voltage levels of up to 850 V DC may occur between terminals +UDC/+BR and -UDC. Not short-circuit protected.

## 3.5 Control Terminals

- All control cable terminals are located underneath the terminal cover in front of the drive.
- See the back of the terminal cover for outlines of control terminals and switches.

**NOTICE**  
Remove the terminal cover with a screwdriver, see illustration 2.

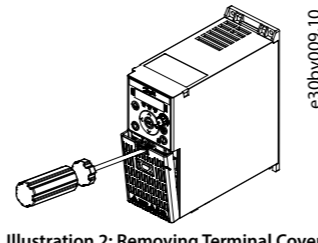

Illustration 2: Removing Terminal Cover

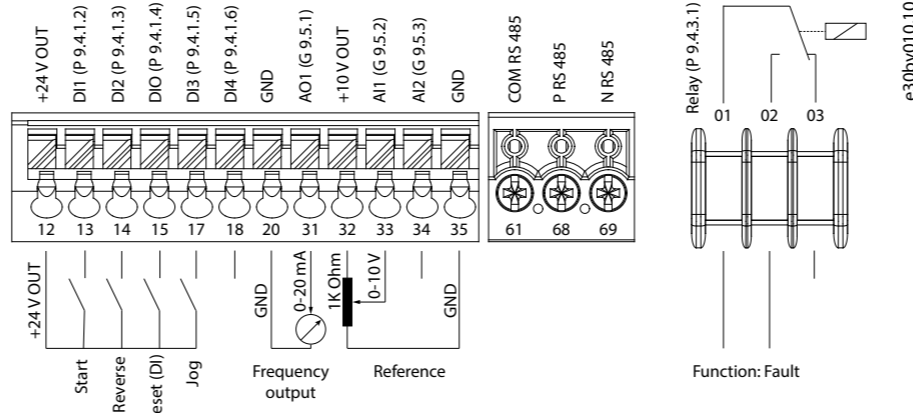

Illustration 3: Overview of Control Terminals in PNP-configuration with Factory Setting (Speed Control Mode)

## 3.6 RJ45 Port and RS485 Termination Switch

The drive has an RJ45 port which complies with Modbus 485 protocol.

The RJ45 port is used for connecting:

- External control panel (Control Panel 2.0 OP2).
- PC tool (MyDrive® Insight) via an adapter option (Quick Adapter USB-C/RJ45 OAX00).

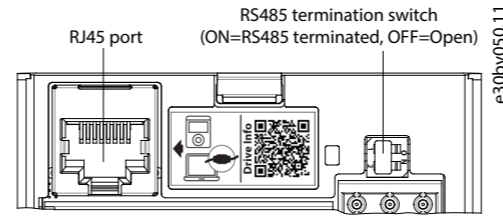

Illustration 4: RJ45 Port and RS485 Termination Switch

**NOTICE**  
- The RJ45 port supports up to 3 m (9.8 ft) of shielded CAT5e cable which is **NOT** used to directly connect the drive to a PC. Failure to follow this notice causes damage to the PC.  
- If the drive is at the end of the fieldbus, set the RS485 termination switch to ON.  
- Do not operate RS485 termination switch when the drive is powered on.

## 4 Programming

### 4.1 Control Panel

Name	Function
Home/Menu	(1) Toggles between status display and main menu. (2) Long press to access the shortcut menu for quickly reading and editing parameters.
Up/Down	Switches status/parameter group/parameter numbers and tunes the parameter values.
Left	Moves the cursor 1 bit to the left.
Back	Navigates to the previous step in the menu structure or cancels the setting during tuning parameter values.
OK	Confirms the operation.
Remote/Local	Toggles between remote and local mode.
Start	Starts the drive in local mode.
Stop/Reset	Stops the drive in local mode, or resets the drive to clear a fault.
Potentiometer	Changes the reference value when the reference value is selected as potentiometer.

Table 4: Status and Operating Indicator Lights

Name	Function	Name	Function
MON	On Shows the drive status.	REV	On The drive is in reverse direction. Off The drive is in forward direction.
PGM	On The drive is in programming status.	ST2	Refer to Table 6 Multiple Setups Indicator Lights.
TOR	On The drive is in torque mode. Off The drive is in speed mode.	WARN	Steadily lit when a warning occurs.
LOC	On The drive is in local mode. Off The drive is in remote mode.	READY	Steadily lit when the drive is ready.
		FAULT	Flashes when a fault occurs.

Table 5: Run Indicator Lights

Name	Function
RUN	On The drive is in normal operation.
	Off The drive has stopped.
	Flash In the motor-stopping process; or the drive received a RUN command, but no frequency output.

Table 6: Multiple Setups Indicator Lights

ST2	Off	On	Flash	Flash quickly
Active setup <sup>(1)</sup>	Setup 1	Setup 2	Setup 1	Setup 2
Programming setup <sup>(2)</sup>	Setup 1	Setup 2	Setup 2	Setup 1

Note:  
(1) Select active setup in parameter P6.6.1 Active Setup.  
(2) Select programming setup in parameter P6.6.2 Programming Setup.

## 4.2 Operation with Control Panel

After the drive is powered up, press the Home/Menu button to toggle between status display and main menu. Use the Up/Down buttons to select items, and press the OK button to confirm selection.

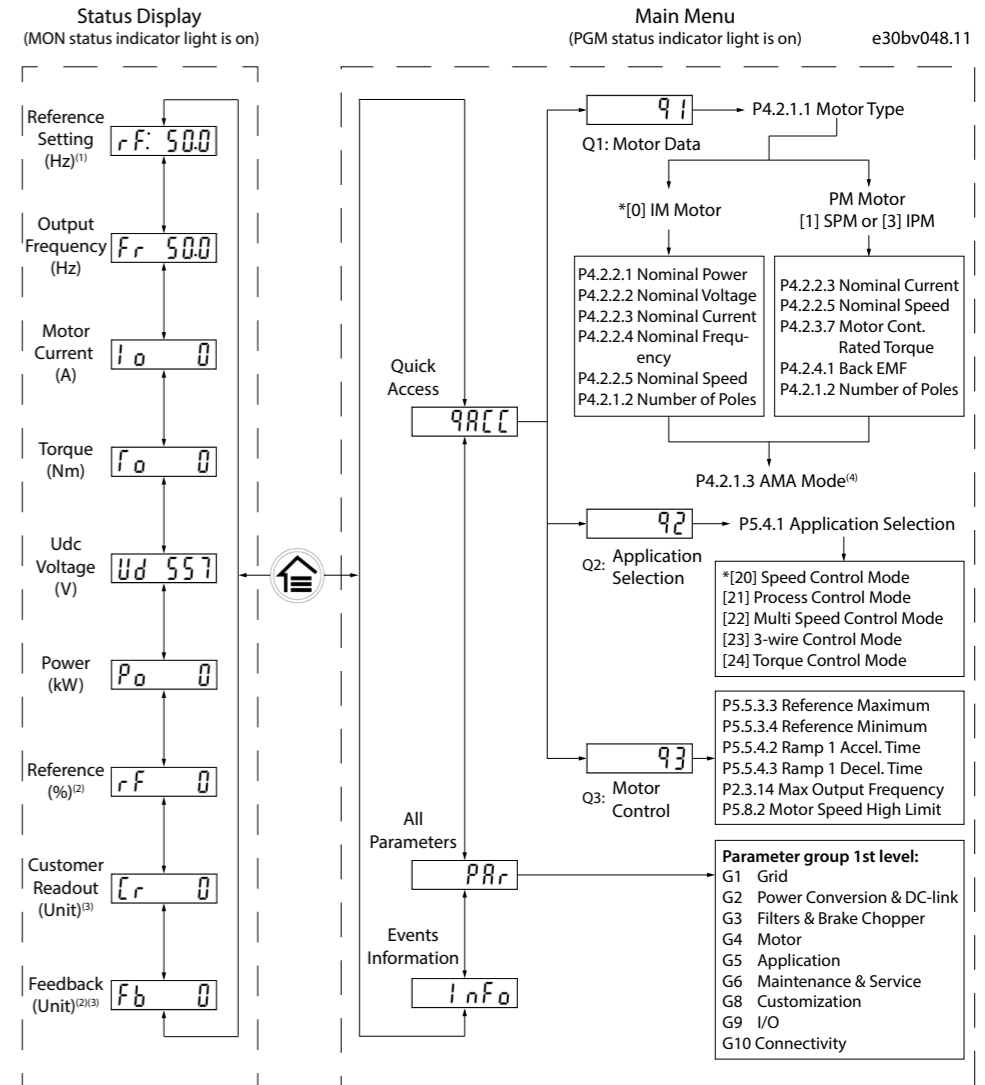

Note: (1) Local mode only. (2) Remote mode only. (3) The status is only shown when the corresponding function is enabled. (4) For AMA execution, refer to chapter Automatic Motor Adaptation (AMA). If parameter P5.4.3 Motor Control Principle is set as [0] U/f, no need to execute AMA.

## 4.3 Automatic Motor Adaptation (AMA)

- Via running AMA in VVC+ mode, the drive builds a mathematical model of the motor to optimize compatibility between drive and motor, and thus enhances the motor control performance.
- Some motors may be unable to run the complete version of the test. In that case, select [2] Enable Reduced AMA in parameter P4.2.1.3 AMA Mode.
- AMA completes within 5 minutes. For best results, run the following procedure on a cold motor.

### Procedure:

- Set motor data according to the motor nameplate.
- If needed, set motor cable length in parameter P4.2.1.4 Motor Cable Length.
- Set [1] Enable Complete AMA or [2] Enable Reduced AMA for parameter P4.2.1.3 AMA Mode, the main display shows To start AMA, see illustration 7.
- Press the Start button, the test runs automatically and the main display indicates when it is completed.
- When AMA is completed, press any button to exit and return to normal operation mode.

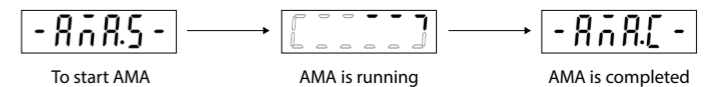

Illustration 7: AMA Status Indications

