

User Manual

Remote Control R13 F Receiver



Revision history

Table of revisions

Date	Changed	Rev
July 2024	Updated Technical Description, Installation and Troubleshooting	0201
January 2019	Rebranded to Danfoss Power Solutions	0101

Contents

Safety instructions

FCC rules.....	4
General safety.....	4
Safety warnings.....	5

Technical description

Dimensions.....	6
Hardware description.....	7
R13F Detailed description.....	7

Installation

Receiver installation.....	9
Recommended Mechanical Installation.....	9
Recommended Wiring Dimensions.....	10
Receiver Pin out.....	10

Troubleshooting

400 - 900MHz Receiver icon troubleshooting.....	12
2.4GHz Receiver Icon Troubleshooting.....	12

Safety instructions

FCC rules

This equipment has been tested and found to comply with the limits for a Class A digital device, pursuant to Part 15 of the FCC Rules.

Changes or modifications not expressly approved by the manufacturer can void the user's authority to operate the equipment.

To comply with FCC RF exposure compliance requirements, this device and its antenna must not be collocated with, or operating in conjunction with, any other antenna or transmitter, may not cause harmful interference, and must accept any interference received, including interference that may cause undesired operation.

The limits are designed to provide reasonable protection against harmful interference when the equipment is operated in a commercial environment. This equipment generates, uses, and can radiate radio frequency energy, and if not installed and used in accordance with the instruction manual, may cause harmful interference to radio communications.

Operation of this equipment in a residential area is likely to cause harmful interference in which case the user will be required to correct the interference at his own expense.

Warning

Le présent appareil est conforme aux CNR d'Industrie Canada applicables aux appareils radio exempts de licence. L'exploitation est autorisée aux deux conditions suivantes:

1. l'appareil ne doit pas produire de brouillage, et
 2. l'utilisateur de l'appareil doit accepter tout brouillage radioélectrique subi, même si le brouillage est susceptible d'en compromettre le fonctionnement.
-

R13 F General Safety

The following safety instructions must be read carefully to install and use the product properly, and to keep it in perfect working condition, and to reduce the risk of miss use.

- **Danfoss recommends the use of ESD PPEs (electrostatic discharge personal protection equipment).**
- Strictly adhere to the installation instructions contained in this document.
- Make sure that professional and competent personnel carry out the installation.
- Ensure that all on site and prevailing safety regulations are fully respected.
- The Electrical Installation where it may be connected, The receiver may be connected through an automatic magneto thermic switch (with omnipolar cut capacitance: F+N) and differential with characteristics according to the Low Voltage Recommendations.
- Make sure that this document is permanently available to the operator and maintenance personnel.
- Keep the transmitter out of reach of non-authorized personnel.
- Remove the transmitter key when the set is not in use.
- Check each working day the STOP button and other safety features. When in doubt, press the STOP button.
- Whenever several sets have been installed, make sure the transmitter is the right one. Identify the machine controlled on the label for this purpose on the transmitter or by using the display (in case it does have one).
- Service the equipment periodically.
- Avoid High Pressure water Spraying to Receivers while cleaning the machine
- When carrying out repairs, use spare parts supplied by Danfoss only.

Safety instructions

Warning

Potential damage to the operator or the product. Do not use this product on machines in potentially explosive atmospheres unless the model is ATEX/RATEX certified to work in such conditions.

R13 F Safety Warnings

Potential damage to operator and product.

Follow the guidelines below to reduce risk of injury to the operator and the product.

- Use the device with the manufacturer's battery and battery charger (if applicable).
- Only allow qualified personnel to operate the equipment.
- Always set the STOP button in the off position when not in use.
- Always press STOP before plugging in tether cable (if applicable).
- Remove the Tether connection on the transmitter First (if applicable).
- Do not operate product when visibility is limited.
- Make sure product is compatible with the machine.
- Avoid knocking or dropping the product.
- Do not use the product if a failure is detected.

Changes or modifications not approved by Danfoss can void the user's authority to operate this product.

Quick reference precautions

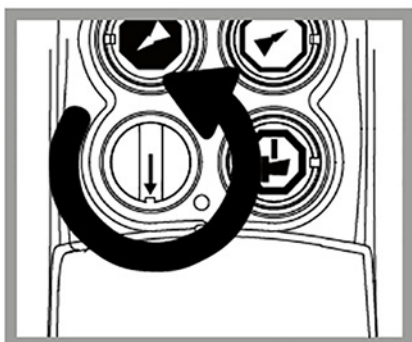

Remove the transmission key only when the set is not in use or to deny the access

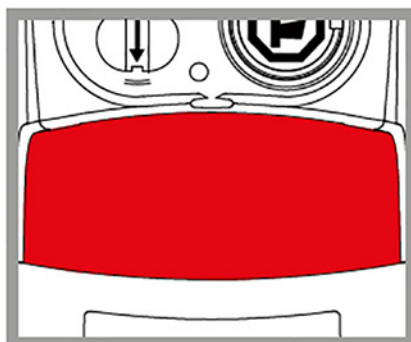

When in doubt, press the STOP button

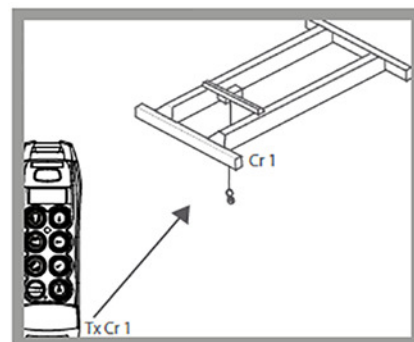

Make sure the transmitter works with the machine to be handled

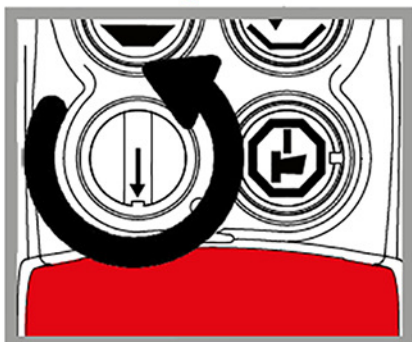

After use set the contact key and the STOP button

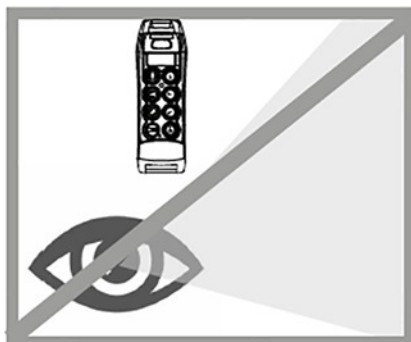

Do not use the set when visibility is limited



Avoid knocking or dropping the set

Technical description

R13 F dimensions

Dimensions in mm

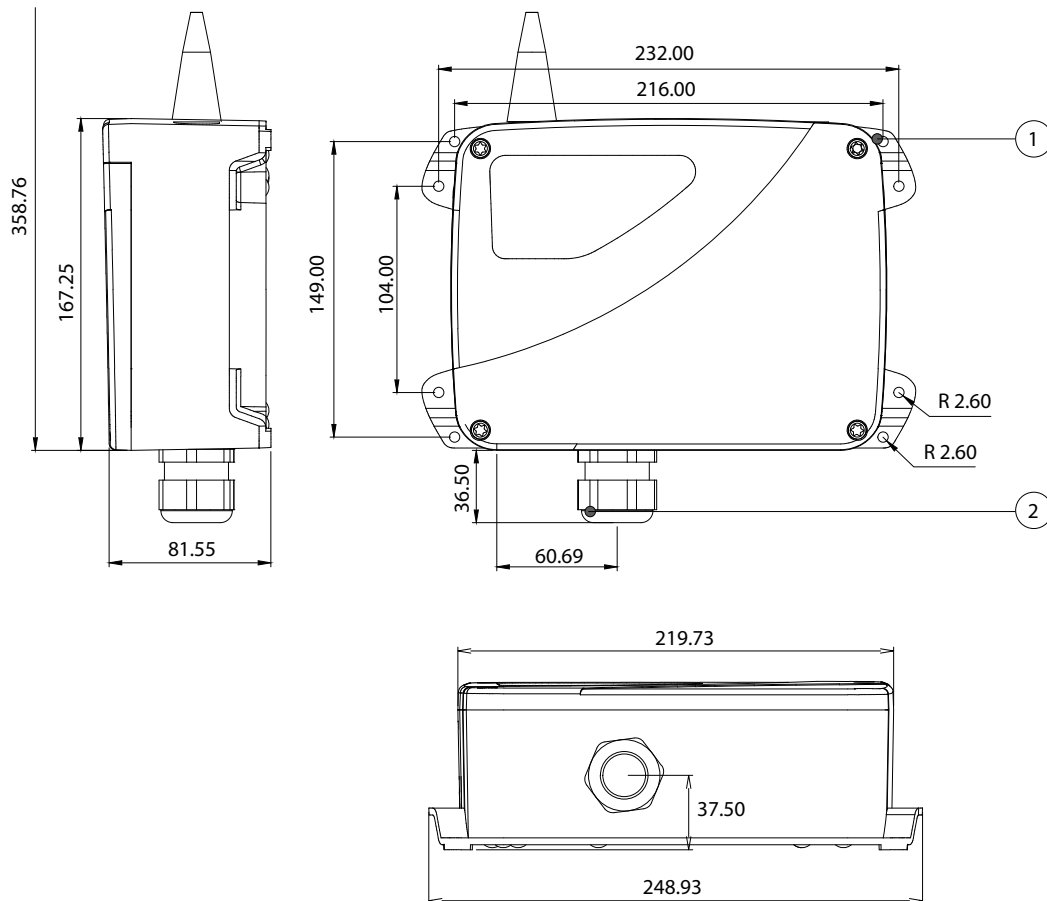

1. Fixing slots (fixed assembly or anti-vibration)
2. M32 cable gland

Technical description

R13 F hardware description

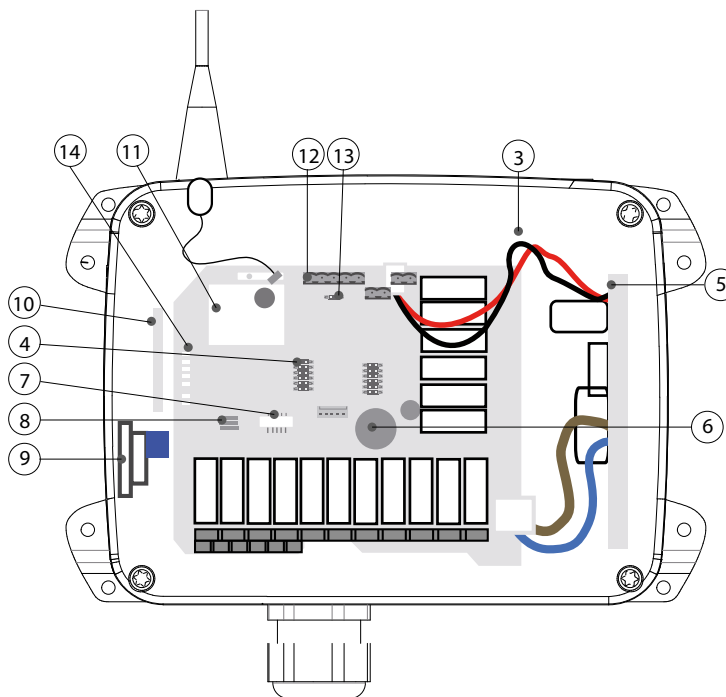

- 3. External antenna Connector
- 4. RS232 / RS485 socket
- 5. Switching Power supply
- 6. LR13 logic board
- 7. Data logger connection
- 8. INXX card socket
- 9. External EEPROM
- 10. LCD connection
- 11. RF Module
- 12. CAN connector
- 13. CAN BUS termination Jumper
- 14. Signalling internal LEDs
- 15. Wiring connection

R13F Detailed description

Technical data

Description	Value
Stop Function (400-900 MHz)	Cat. 3-PLd
Stop Function (2.4GHz)	Cat 4 - PLe
Ingress Protection rating	IP65/NEMA4

Technical description

Technical data (continued)

Description	Value
Frequency band - ERP	433.050 to 434.040 MHz; ERP<1mW
	434.040 to 434.790 MHz; ERP<10mW
	869.700 to 870.000 MHz; ERP<5mW
	902.000 to 928.000 MHz; ERP<1mW
	2405MHz to 2475MHz 20dBm/100mW
Range Line of sight (guaranteed)	100m
AC power supply	48 - 240 Vac / 18 - 30 Vac (700mA)
DC power supply	8 - 36 Vdc (2A)
Antenna	External
Removable EEPROM	External
Signaling	External
STOP Outputs (400-900MHz)	1 (6A)
STOP Outputs (2.4GHz)	2 (6A)
Start Output	1 (8A)
Safety Relay	1 (8A)
ON/OFF outputs	13 (8A)
Proportional outputs	Option
CAN Bus Protocols	CANopen
ON/OFF inputs	Option
Proportional Inputs (maximum)	Option
Maximum output current	8A
Response Time:	100ms
Operating Temperature Range	-20 °C to 70 °C (-4 °F to 158 °F)
Storage Temperature Range (24h)	-25°C to 75°C (-13°F to 167°F)
Storage Temperature Range (long periods)	-25°C to 55°C (-13°F to 131°F)
Relative Humidity	max. 95% without condensation
Weight	1350g
Dimensions (LxWxH mm)	245x160x80
Tether Connector	YES (M12 Connector)
Associated Transmitters (400-900 MHz)	Ikargo1, Ikargo2, T70/1, T70/2, T70/1 HALL, T70/2 HALL, IK2, IK3, IK4
Associated Transmitters (2.4 GHz)	Ikore, IkoreB, Icompact, Ikargo1, Ikargo2, IK1, IK2, IK3, IK4
Options	
CAN Bus Protocols	Profibus DP, Profinet (400-900MHz)
ON/OFF outputs	8 (8A)
Proportional Outputs	4 (PWM or Voltage)
Inputs	24 ON/OFF Inputs or 6 Analog Inputs

Installation

R13 F receiver installation

The below information describes hazards to be aware of during installation and steps to locate the receiver.

Risk of shock

Completely shut down the machine when installing the receiver.

Check the power supply and shut off the main switch to disconnect the interface cable between the receiver and the machine's electrical box.

1. Find an easily accessible and clear location with a direct vision between the receiver's antenna and the transmitter's working area.

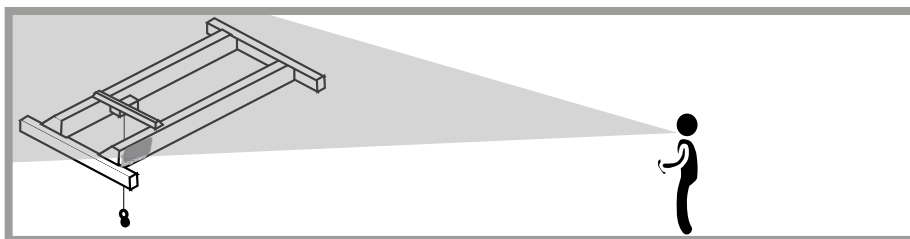

2. Optional: If it is difficult to achieve direct vision between the receiver's antenna and the transmitter's working area, it is recommended to use an extended antenna in a clear location (only for models that allow an antenna).

In areas of high vibration, the use of Shock Absorbers is advised.

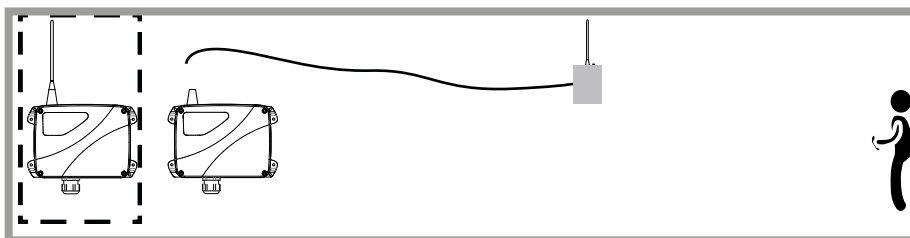

3. Proceed to connect the power supply. Use the connection block diagram provided with the system, where the correspondence between the transmitter maneuvers and the receiver's outputs are detailed.

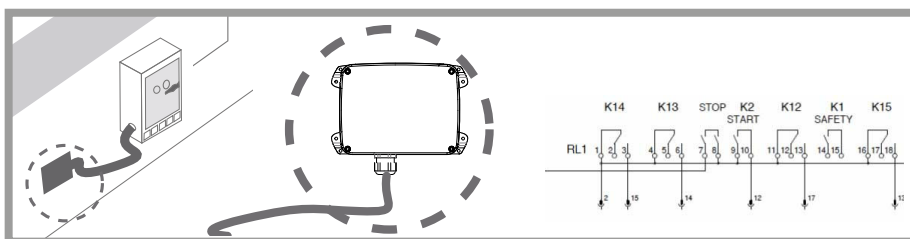

4. Check if the electrical installation and verify if there's an option to connect the neutral or the ground cable. In that case, don't forget to connect the ground cable.

The use of fireproof or flame retardant cables are recommended for the connection.

Recommended Mechanical Installation

At the time of installing the Receiver on the structure of the machine the following mechanical installation is recommended depending on the type of Receiver Enclosure:

Installation

Receiver

Receiver Model	Hole Diameter(mm)	Recommended Screw	Comments
R06	5 mm	DIN 7985 M5x25	
R13, MP20	5 mm	DIN 7985 M5x25	
R11	5 mm	DIN 7985 M5x25	
R70	9 mm	DIN 7985 M8x25	M6 screw with washer could be used as well
MP08, MPCAN	5 mm	DIN 7985 M5x25	
MP15	5 mm	DIN 7985 M5x25	

We do recommend to use Shock absorbers and Magnet Kit for the different Receivers:

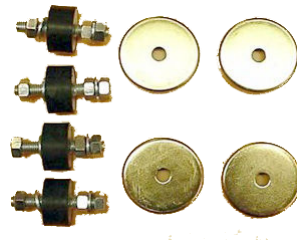

Recommended Wiring Dimensions

Depending on the Destination country of the Receiver the wiring must comply with the corresponding international approvals. Our recommended wiring solution is an Oil Resistant Flexible Control Cable with International approvals, now with <HAR> approval for use as a Machinery Interconnection Cable.

Wiring section and Number of conductors

AWG	Number of Conductors	Nominal Outer Diameter	Approx weight
1.50 mm ²	18	17.8mm	518kg/km
1.50 mm ²	25	21.5mm	730kg/km

Receiver Pin out

R13F Receiver Pinout is as follows.

TM70 R13F Pin out

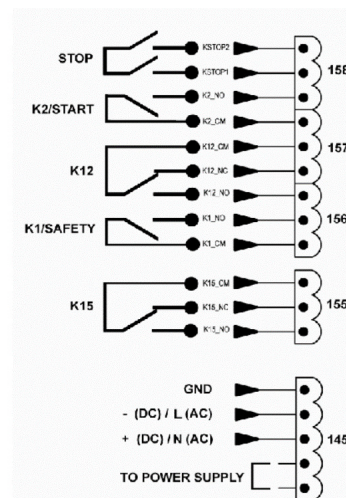
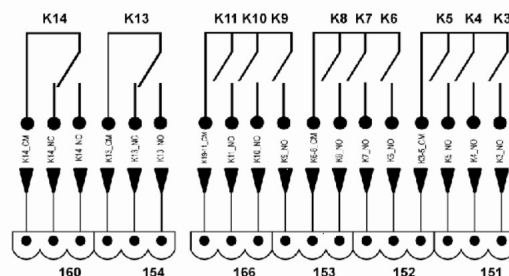

Installation

TM80 R13F Pin out

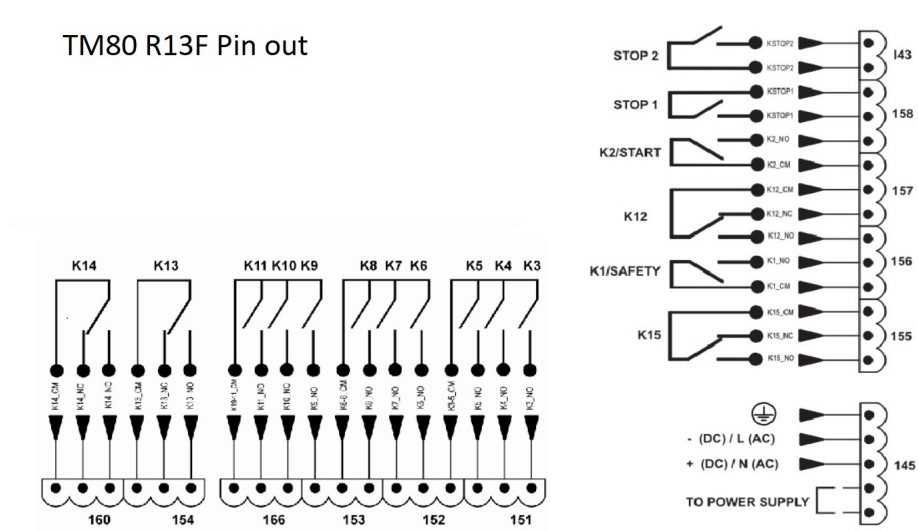









Troubleshooting

400 - 900MHz Receiver icon troubleshooting

The troubleshooting Display is located on the receiver side, accessible from the outside. Use the following table to identify faults and corrective action.

Please do check the following website for further information:

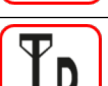
<https://troubleshooting.dps-rct.com/en/customer-service-center>

Icon	Description	Action
	Power failure	Check the receiver power supply
	Hardware error	Contact distributor; replace receiver
	CAN error	Contact your distributor
	Standby state due to active stop	Transmitter has been switched off by pressing the STOP button. Release stop button and turn transmitter on
	Standby state due to passive stop	Receiver has lost contact with Transmitter due to interference or Transmitter out of range. Press Start on Transmitter.
	Linked state	Correct link
	Correct ID (link quality as indicated by the bar)	In case of no signal, check if the transmitter is turned on
	Incorrect ID	In case of interference, change frequency channel
	RF signal detected	In case of interference, change frequency channel
	Mask error	Contact your distributor

2.4GHz Receiver Icon Troubleshooting

The troubleshooting Display is located on the receiver side, accessible from the outside. Use the following table to identify faults and corrective action.

In order to reach the internal signaling LEDs, the receiver must be accessible, connected, and the screws located on the receiver lid must be unscrewed using the proper screw driver. The LEDs on the receiver board are POWER, STATUS, DIAG1, DIAG2, ORDER, RELAY, CANERR and CANRUN in that order.

Please do check the following website for further information:

<https://troubleshooting.dps-rct.com/en/customer-service-center>

Troubleshooting

Icon	Description	Action
	Power Fail	Check power supply
	Hardware Error	Replace Receiver
	CAN Error	Verify CAN connections and Status.
	Standby State due to Active STOP	Release STOP button and press START on the transmitter.
	Standby State due to Pasive Stop	Press Start on the Transmitter
	Linked Status	System working Correctly
	Mask Error	Check EEPROM and reprogram if necessary
	Receiver Initializing	Wait
	Radio communication error	Replace Receiver
	EEPROM module missing or corrupt	Check EEPROM and reprogram if necessary
	Hardware Error	Replace Receiver
	CAN Bus configuration Error	Verify CAN Connections, addresses of Expansion boards and Bus terminations
	Standby and Operation Screen	Representation of Inputs and outputs being active at a time

Products we offer:

- Cartridge valves
- DCV directional control valves
- Electric converters
- Electric machines
- Electric motors
- Gear motors
- Gear pumps
- Hydraulic integrated circuits (HICs)
- Hydrostatic motors
- Hydrostatic pumps
- Orbital motors
- PLUS+1® controllers
- PLUS+1® displays
- PLUS+1® joysticks and pedals
- PLUS+1® operator interfaces
- PLUS+1® sensors
- PLUS+1® software
- PLUS+1® software services, support and training
- Position controls and sensors
- PVG proportional valves
- Steering components and systems
- Telematics

Danfoss Power Solutions is a global manufacturer and supplier of high-quality hydraulic and electric components. We specialize in providing state-of-the-art technology and solutions that excel in the harsh operating conditions of the mobile off-highway market as well as the marine sector. Building on our extensive applications expertise, we work closely with you to ensure exceptional performance for a broad range of applications. We help you and other customers around the world speed up system development, reduce costs and bring vehicles and vessels to market faster.

Danfoss Power Solutions – your strongest partner in mobile hydraulics and mobile electrification.

Go to www.danfoss.com for further product information.

We offer you expert worldwide support for ensuring the best possible solutions for outstanding performance. And with an extensive network of Global Service Partners, we also provide you with comprehensive global service for all of our components.

Local address:

Hydro-Gear

www.hydro-gear.com

Daikin-Sauer-Danfoss

www.daikin-sauer-danfoss.com

**Danfoss
Power Solutions (US) Company**
2800 East 13th Street
Ames, IA 50010, USA
Phone: +1 515 239 6000

**Danfoss
Power Solutions GmbH & Co. OHG**
Krokamp 35
D-24539 Neumünster, Germany
Phone: +49 4321 871 0

**Danfoss
Power Solutions ApS**
Nordborgvej 81
DK-6430 Nordborg, Denmark
Phone: +45 7488 2222

**Danfoss
Power Solutions Trading
(Shanghai) Co., Ltd.**
Building #22, No. 1000 Jin Hai Rd
Jin Qiao, Pudong New District
Shanghai, China 201206
Phone: +86 21 2080 6201

Danfoss can accept no responsibility for possible errors in catalogues, brochures and other printed material. Danfoss reserves the right to alter its products without notice. This also applies to products already on order provided that such alterations can be made without subsequent changes being necessary in specifications already agreed. All trademarks in this material are property of the respective companies. Danfoss and the Danfoss logotype are trademarks of Danfoss A/S. All rights reserved.