

ENGINEERING
TOMORROW



User Manual

Remote Control R70 PLUS Receiver



Revision history

Table of revisions

Date	Changed	Rev
July 2024	Updated safety, technical description, installation, and troubleshooting	0201
January 2019	Rebranded to Danfoss Power Solutions	0101

Contents

Safety instructions

FCC rules.....	4
General safety.....	4
Safety warnings.....	5

Technical description

Dimensions.....	6
Hardware description.....	7

Installation

Receiver installation.....	8
Expansion cards.....	9
Internal wiring.....	10
Recommended Mechanical Installation.....	10
Recommended Wiring Dimensions.....	11

Troubleshooting

R70 PLUS troubleshooting.....	12
2.4GHz Receiver LED troubleshooting.....	12

Safety instructions

FCC rules

This equipment has been tested and found to comply with the limits for a Class A digital device, pursuant to Part 15 of the FCC Rules.

Changes or modifications not expressly approved by the manufacturer can void the user's authority to operate the equipment.

To comply with FCC RF exposure compliance requirements, this device and its antenna must not be collocated with, or operating in conjunction with, any other antenna or transmitter, may not cause harmful interference, and must accept any interference received, including interference that may cause undesired operation.

The limits are designed to provide reasonable protection against harmful interference when the equipment is operated in a commercial environment. This equipment generates, uses, and can radiate radio frequency energy, and if not installed and used in accordance with the instruction manual, may cause harmful interference to radio communications.

Operation of this equipment in a residential area is likely to cause harmful interference in which case the user will be required to correct the interference at his own expense.

Warning

Le présent appareil est conforme aux CNR d'Industrie Canada applicables aux appareils radio exempts de licence. L'exploitation est autorisée aux deux conditions suivantes:

1. l'appareil ne doit pas produire de brouillage, et
 2. l'utilisateur de l'appareil doit accepter tout brouillage radioélectrique subi, même si le brouillage est susceptible d'en compromettre le fonctionnement.
-

R70 PLUS General Safety

The following safety instructions must be read carefully to install and use the product properly, and to keep it in perfect working condition, and to reduce the risk of miss use.

- **Danfoss recommends the use of ESD PPEs (electrostatic discharge personal protection equipment).**
- Strictly adhere to the installation instructions contained in this document.
- Make sure that professional and competent personnel carry out the installation.
- Ensure that all on site and prevailing safety regulations are fully respected.
- The Electrical Installation where it may be connected, The receiver may be connected through an automatic magneto thermic switch (with omnipolar cut capacitance: F+N) and differential with characteristics according to the Low Voltage Recommendations.
- Make sure that this document is permanently available to the operator and maintenance personnel.
- Keep the transmitter out of reach of non-authorized personnel.
- Remove the transmitter key when the set is not in use.
- Check each working day the STOP button and other safety features. When in doubt, press the STOP button.
- Whenever several sets have been installed, make sure the transmitter is the right one. Identify the machine controlled on the label for this purpose on the transmitter or by using the display (in case it does have one).
- Service the equipment periodically.
- Avoid High Pressure water Spraying to Receivers while cleaning the machine
- When carrying out repairs, use spare parts supplied by Danfoss only.

Safety instructions

Warning

Potential damage to the operator or the product. Do not use this product on machines in potentially explosive atmospheres unless the model is ATEX/RATEX certified to work in such conditions.

R70 PLUS Safety Warnings

Potential damage to operator and product.

Follow the guidelines below to reduce risk of injury to the operator and the product.

- Use the device with the manufacturer's battery and battery charger (if applicable).
- Only allow qualified personnel to operate the equipment.
- Always set the STOP button in the off position when not in use.
- Always press STOP before plugging in tether cable (if applicable).
- Remove the Tether connection on the transmitter First (if applicable).
- Do not operate product when visibility is limited.
- Make sure product is compatible with the machine.
- Avoid knocking or dropping the product.
- Do not use the product if a failure is detected.

Changes or modifications not approved by Danfoss can void the user's authority to operate this product.

Quick reference precautions

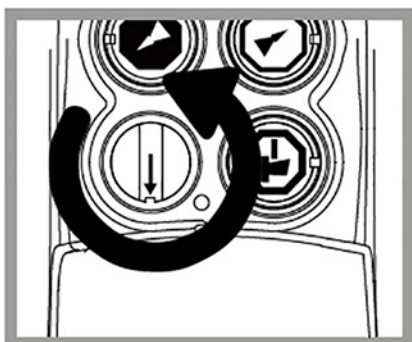

Remove the transmission key only when the set is not in use or to deny the access

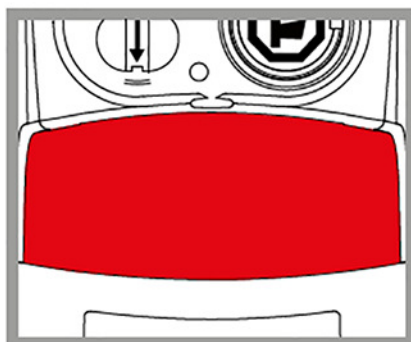

When in doubt, press the STOP button

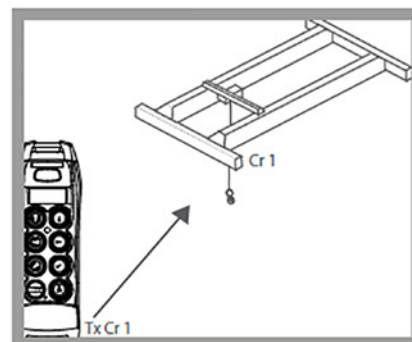

Make sure the transmitter works with the machine to be handled

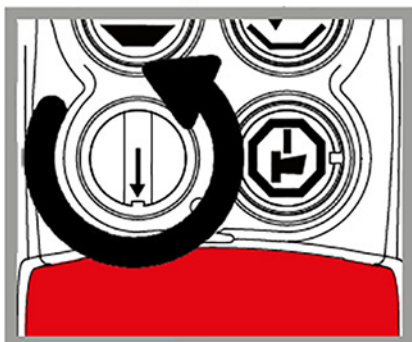

After use set the contact key and the STOP button

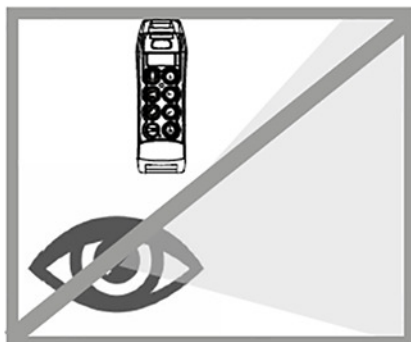

Do not use the set when visibility is limited



Avoid knocking or dropping the set

Technical description

R70 PLUS dimensions

Dimensions in mm

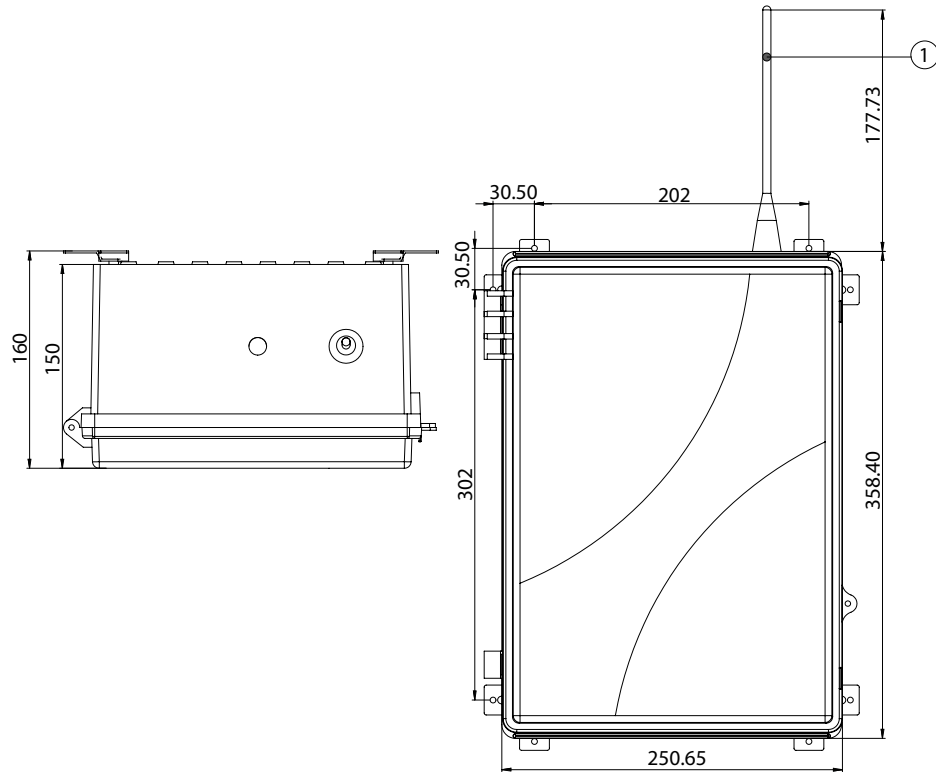

1. External antenna A60 (433) or A70 (870)

[See next page for receiver board description.](#)

Technical description

R70 PLUS hardware description

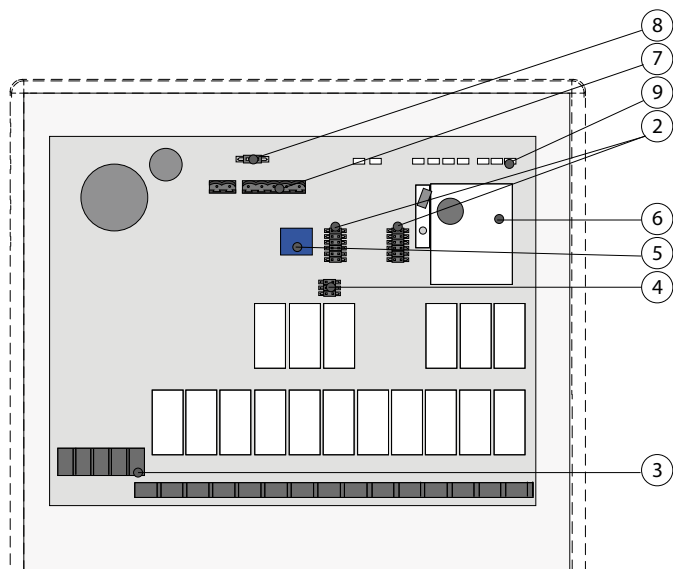

- 2. RS232/RS485 socket
- 3. Power supply
- 4. INXXX card socket
- 5. Internal removable EEPROM
- 6. RF Module
- 7. CAN connection
- 8. CAN BUS termination
- 9. Signaling intern LEDs
- 10. Wiring connection

Installation

R70 PLUS receiver installation

The below information describes hazards to be aware of during installation and steps to locate the receiver.

Risk of shock

Completely shut down the machine when installing the receiver.

Check the power supply and shut off the main switch to disconnect the interface cable between the receiver and the machine's electrical box.

1. Find an easily accessible and clear location with a direct vision between the receiver's antenna and the transmitter's working area.

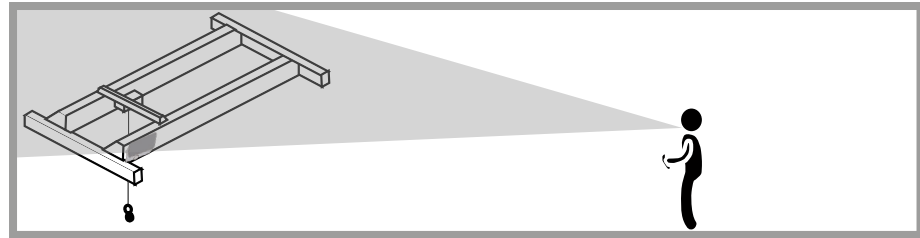

2. Optional: If it is difficult to achieve direct vision between the receiver's antenna and the transmitter's working area, it is recommended to use an extended antenna in a clear location (only for models that allow an antenna).

In areas of high vibration, the use of Shock Absorbers is advised.

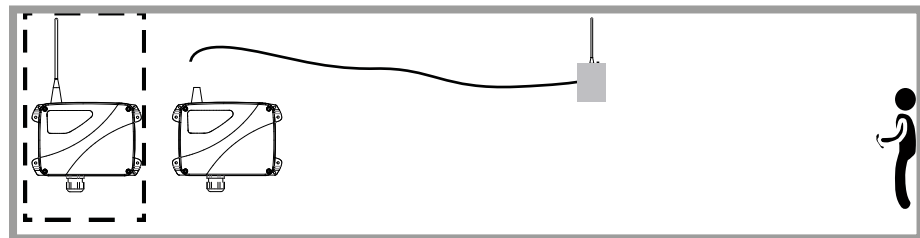

3. Proceed to connect the power supply. Use the connection block diagram provided with the system, where the correspondence between the transmitter maneuvers and the receiver's outputs are detailed.

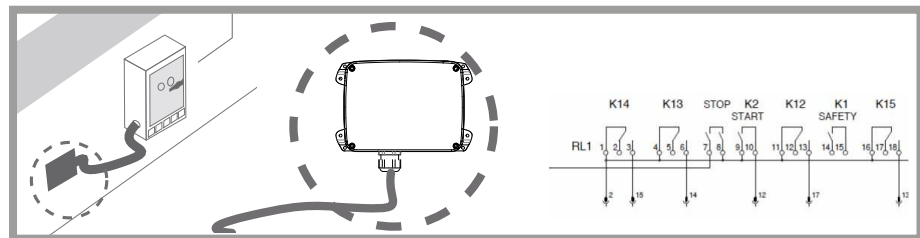

4. Check if the electrical installation and verify if there's an option to connect the neutral or the ground cable. In that case, don't forget to connect the ground cable.

The use of fireproof or flame retardant cables are recommended for the connection.

Installation

R70 PLUS expansion cards

The R70 PLUS receiver box can be used when there is not enough space for the expansion cards configuration.

The R70 PLUS is set up with the LR13F electronic card and a power supply, if necessary to connect more than two expansion cards.

The software allows to include in the same box up to 53 relays or up to 10 analogue outputs.

The maximum number of expansion cards permitted is detailed in the table below:

Expansion card	Slot size	Max. number of expansions
R8CAN	1/2	5
A1P4RCAN	1/2	5
INCAN	1/2	5
IN 0-10V	Direct assembly in LR72 or INCAN cards	-
IN 0-45P	Direct assembly in LR72 or INCAN cards	-
IN4D	Direct assembly in LR72 or INCAN cards	-
A2ICAN	1/4	5
A2VCAN	1/4	5

Installation

R70 PLUS internal wiring

The power cables must be wired and guided from the center of the slot. The rest of the CAN bus wiring can be placed without any restriction.

Upper slot

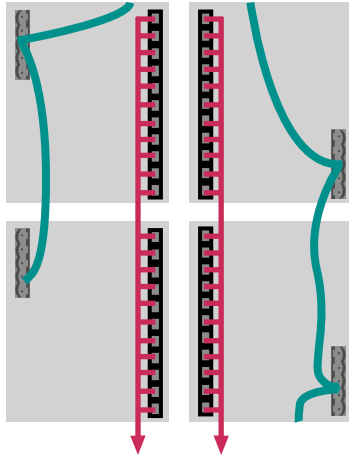

Bottom slot

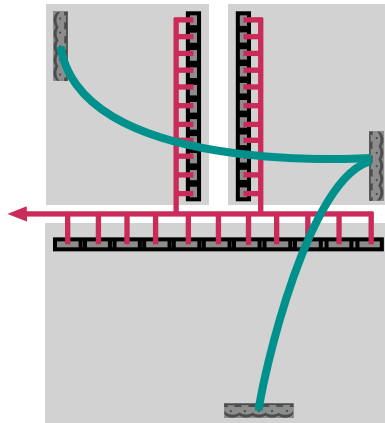

Green wire

CAN bus wiring

Red wire

Power wiring

Recommended Mechanical Installation

At the time of installing the Receiver on the structure of the machine the following mechanical installation is recommended depending on the type of Receiver Enclosure:

Receiver

Receiver Model	Hole Diameter(mm)	Recommended Screw	Comments
R06	5 mm	DIN 7985 M5x25	
R13, MP20	5 mm	DIN 7985 M5x25	
R11	5 mm	DIN 7985 M5x25	

Installation

Receiver (continued)

Receiver Model	Hole Diameter(mm)	Recommended Screw	Comments
R70	9 mm	DIN 7985 M8x25	M6 screw with washer could be used as well
MP08, MPCAN	5 mm	DIN 7985 M5x25	
MP15	5 mm	DIN 7985 M5x25	

We do recommend to use Shock absorbers and Magnet Kit for the different Receivers:

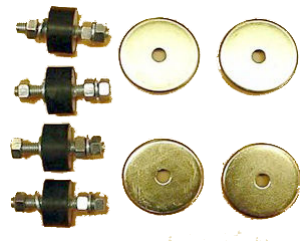

Recommended Wiring Dimensions

Depending on the Destination country of the Receiver the wiring must comply with the corresponding international approvals. Our recommended wiring solution is an Oil Resistant Flexible Control Cable with International approvals, now with <HAR> approval for use as a Machinery Interconnection Cable.

Wiring section and Number of conductors

AWG	Number of Conductors	Nominal Outer Diameter	Approx weight
1.50 mm ²	18	17.8mm	518kg/km
1.50 mm ²	25	21.5mm	730kg/km

Troubleshooting

R70 PLUS400-900MHz LED troubleshooting

LED	Characteristic	Description	Action
POWER	Green; pulsing	Receiver is starting up	Wait until start-up process is finished
HARDOK	Green; continuous	Receiver hardware OK	Operate
	Red; pulsing	EEPROM error; data corruption; CAN bus error (if CANERR activates)	Reprogram EEPROM
	Red; other	Electronic board hardware breakdown	Replace electronic board
SIGNAL	LED off	No radio signal detected	-
	LED on + transmitter switched off	Radio channel occupied	Change transmitter's frequency channel
	LED on + DATA switched off	Radio channel occupied by non Danfoss system	Change transmitter's frequency channel
DATA	Green; pulsing	Receiving good frames	OK
ID	LED off + DATA LED on	No valid ID; Danfoss system nearby	If channel not occupied, check chosen ID in the transmitter or reset the receiver
	LED on + SIGNAL LED on + DATA LED on	Valid frames received from the transmitter; correct link	OK
RELAY	Green	STOP relay activated	-
ORDER	Green	-	-
CAN_RUN	Green; switched on	Operational state	OK
	Green; pulsing	Activating operational state	-
CAN_ERR	Red; switched on	CAN bus error	Check CAN connection
	Red; pulsing	No bus connection	Check bus termination resistance
	LED off	Correct communication	OK

2.4GHz Receiver LED troubleshooting

The troubleshooting LEDs are located on the receiver board or accessible on the outside. Use the following table to identify faults and corrective action.

In order to reach the internal signaling, the receiver must be accessible, connected and the screws located on the receiver lid must be unscrewed using the proper screw driver whenever the LEDs are not externally visible.

The LEDs on the receiver board are POWER, STATUS, DIAG1, DIAG2, ORDER, RELAY, CANERR and CANRUN in that order.









Please do check the following website for further information:

<https://troubleshooting.dps-rct.com/en/customer-service-center>

Troubleshooting

LED	Color and frequency	Pulse frequency	Description	Action
POWER	Green continuous		Switched ON if powered	Check power supply if LED is switched off.
STATUS	Blue fast pulses		System is starting; establishing connection with radio and EEPROM	Wait
	Blue continuous		Waiting for transmitter communication, coming from ACTIVE STOP	Release STOP button and press START on the transmitter.
	Blue slow pulses		Waiting for transmitter communication, coming from PASSIVE STOP	Press Start on the Transmitter
	Green continuous		Working	Operate
	Red slow pulses		EEPROM module missing or corrupt	Check EEPROM and reprogram if necessary
	Red double pulses		Radio communication error	Replace receiver
	Red triple pulses		Secondary micro error or error between micro communication	Replace receiver
	Red 4 pulses		ERROR	Check DIAG1 LED
	Red 5 pulses		After 15 sec Not all expansion boards have been initialized	Check CAN wiring and Configuration(EEP or Expansion ID#), Check Bus Termination.
	Red 1 Long + 1 short pulse		CAN Signature ERROR	Check Signature in Compliance Block and EEPROM are the same.
DIAG1	Orange slow pulses		Low tension in the receivers power supply	Supply the system with the correct voltage
	Orange double pulses		Hardware error	Replace receiver
	Orange triple pulses			
	Orange 4 pulses			
	Green slow pulses		Low link quality	N/A
	Green double pulses		Medium link quality	N/A
	Green triple pulses		High link quality	N/A
DIAG2	NOT USED	NOT USED	NOT USED	N/A

Troubleshooting

LED	Color and frequency	Pulse frequency	Description	Action
ORDER	Green continuous		LED ON Whenever any output is ON	N/A
RELAY	Green continuous		STOP relay activated	N/A
CANERR	Red slow pulses		CAN Error, physical Layer	Verify Connections
	Red double pulses		One expansion has Stopped working	Verify Expansion boards
	Red 4 pulses		A Transmitted CAN frame has been lost	N/A
	Red 5 pulses		A Received CAN Frame has been lost	N/A
	Red continuous		CAN Bus OFF	Verify CAN connections and Status.
CANRUN	Green fast pulses		Pre operational Status, Receiver waiting for the controller.	Controller must send the Operational code to the Receiver.
	Green continuous		Receiver connected to the CAN network and operational	N/A

Products we offer:

- Cartridge valves
- DCV directional control valves
- Electric converters
- Electric machines
- Electric motors
- Gear motors
- Gear pumps
- Hydraulic integrated circuits (HICs)
- Hydrostatic motors
- Hydrostatic pumps
- Orbital motors
- PLUS+1® controllers
- PLUS+1® displays
- PLUS+1® joysticks and pedals
- PLUS+1® operator interfaces
- PLUS+1® sensors
- PLUS+1® software
- PLUS+1® software services, support and training
- Position controls and sensors
- PVG proportional valves
- Steering components and systems
- Telematics

Danfoss Power Solutions is a global manufacturer and supplier of high-quality hydraulic and electric components. We specialize in providing state-of-the-art technology and solutions that excel in the harsh operating conditions of the mobile off-highway market as well as the marine sector. Building on our extensive applications expertise, we work closely with you to ensure exceptional performance for a broad range of applications. We help you and other customers around the world speed up system development, reduce costs and bring vehicles and vessels to market faster.

Danfoss Power Solutions – your strongest partner in mobile hydraulics and mobile electrification.

Go to www.danfoss.com for further product information.

We offer you expert worldwide support for ensuring the best possible solutions for outstanding performance. And with an extensive network of Global Service Partners, we also provide you with comprehensive global service for all of our components.

Local address:

Hydro-Gear

www.hydro-gear.com

Daikin-Sauer-Danfoss

www.daikin-sauer-danfoss.com

**Danfoss
Power Solutions (US) Company**
2800 East 13th Street
Ames, IA 50010, USA
Phone: +1 515 239 6000

**Danfoss
Power Solutions GmbH & Co. OHG**
Krokamp 35
D-24539 Neumünster, Germany
Phone: +49 4321 871 0

**Danfoss
Power Solutions ApS**
Nordborgvej 81
DK-6430 Nordborg, Denmark
Phone: +45 7488 2222

**Danfoss
Power Solutions Trading
(Shanghai) Co., Ltd.**
Building #22, No. 1000 Jin Hai Rd
Jin Qiao, Pudong New District
Shanghai, China 201206
Phone: +86 21 2080 6201

Danfoss can accept no responsibility for possible errors in catalogues, brochures and other printed material. Danfoss reserves the right to alter its products without notice. This also applies to products already on order provided that such alterations can be made without subsequent changes being necessary in specifications already agreed. All trademarks in this material are property of the respective companies. Danfoss and the Danfoss logotype are trademarks of Danfoss A/S. All rights reserved.