

ENGINEERING  
TOMORROW



Design Guide

# iC7-Automation Frequency Converters

1.3–1260 A



[drives.danfoss.com](https://drives.danfoss.com) | **iC7**



# Contents

## 1 Introduction

1.1 Purpose of this Design Guide	11
1.2 Intended Use	11
1.3 Additional Resources	11
1.4 Planning and Design Support Materials	12
1.4.1 Overview	12
1.4.2 Locating Support Information	12
1.5 Version History	12

## 2 Safety

2.1 Safety	14
2.2 Safety Symbols	14
2.3 Medical Devices	14
2.4 General Safety Considerations	15
2.5 Qualified Personnel	16

## 3 Approvals and Certifications

3.1 Product Approvals and Certifications	17
3.2 Standards	18
3.3 Export Control Regulation	18

## 4 Danfoss iC7 Series

4.1 Overview	20
4.2 Ecodesign for Power Drive Systems	20
4.2.1 Overview	20
4.2.2 Power Losses and Efficiency	21

## 5 iC7 Frequency Converters

5.1 Overview	23
5.2 Drive Models and Frame Designations	23
5.3 Power Unit	23
5.4 Power Unit Options	25
5.5 Control Unit and Interfaces	25

5.5.1 Control Unit and Interfaces	25
5.5.2 Control Board and Standard I/O	26
5.5.3 Communication Interfaces	27
5.5.4 Control Panels	27
5.5.5 Functional Safety	27
5.6 Overload Capability	28
5.6.1 Load Profile Overview	28
5.6.2 Low Overload (LO)	28
5.6.3 High Overload (HO1)	28
5.6.4 High Overload with Increased Duty (HO2)	29
<b>6 iC7-Automation Application Software</b>	
6.1 Overview	30
6.2 Basic Functions	30
6.3 Controllers	32
6.4 Motor Control Features	33
6.5 Protection Features	34
6.6 Monitoring Features	35
6.7 Functional Safety	36
6.8 Security Features	36
6.9 Motion Application Software Features	36
6.10 Software Tools	37
<b>7 Options and Accessories</b>	
7.1 Overview of Options and Accessories	39
7.2 Fieldbus Options	39
7.3 Functional Extension Options	39
7.3.1 Overview	39
7.3.2 Option Slots	39
7.4 Filters and Braking Options	42
7.4.1 Sine-wave Filters	42
7.4.2 dU/dt Filters	42
7.4.3 Common-mode Filters	42
7.4.4 Harmonic Filters	42
7.4.5 Brake Resistors	42

7.4.6	Braking with the Frequency Converter	43
7.4.6.1	Overview of Braking with the Frequency Converter	43
7.4.6.2	Resistor Braking	43
7.4.6.3	Selecting a Brake Resistor	43
7.4.6.4	Brake Performance Considerations	44
7.4.6.5	Brake Resistor Installation Considerations	45
7.5	Kits and Accessories	46
7.5.1	Overview of Kits and Accessories	46
7.5.2	Back-channel Cooling Kits	46
7.5.3	Pedestal Kits	46
7.5.4	Control Panel Mounting Kits and Cables	46
7.5.5	Cable and Wire Installation Kits	47
<b>8</b>	<b>Specifications</b>	
8.1	Overview	48
8.2	Ratings	48
8.2.1	Overview	48
8.2.2	Ratings for Frequency Converters with 380–500 V Supply Voltage	48
8.2.3	Current and Power Ratings 380–440 V AC	49
8.2.4	Current and Power Ratings 441–480 V AC	50
8.2.5	Current and Power Ratings 481–500 V AC	52
8.2.6	Brake Ratings 380–500 V AC	53
8.3	General Technical Data	54
8.3.1	Grid Side	54
8.3.2	Motor Output and Motor Data	55
8.3.3	Torque Characteristics	55
8.3.4	Control Characteristics	56
8.3.5	Control I/O	56
8.3.5.1	Overview	56
8.3.5.2	Analog Input	56
8.3.5.3	Analog Output	57
8.3.5.4	Digital and Encoder/Pulse Input	57
8.3.5.5	Digital and Pulse Output	58
8.3.5.6	Relay Output	58
8.3.5.7	Auxiliary Voltages	59
8.3.6	Functional Safety	59
8.3.6.1	Functional Safety Standards and Performance	59

8.3.6.2	Functional Safety I/O	61
8.3.7	Interface Board	62
8.3.8	Ambient Conditions	62
8.3.8.1	Overview	62
8.3.8.2	Ambient Conditions during Storage	62
8.3.8.3	Ambient Conditions during Transport	63
8.3.8.4	Ambient Conditions during Operation	63
8.3.9	Discharge Times	64
8.4	Fuses and Circuit Breakers	64
8.4.1	Overview	64
8.4.2	IEC Compliant Fuses	65
8.4.3	UL Compliant Fuses	67
8.4.4	IEC Compliant Circuit Breakers	70
8.4.5	UL Compliant Circuit Breakers and Combination Motor Controllers	71
8.4.6	Protection of DC Interface	71
8.5	Power Connectors	72
8.6	Cooling and Power Loss	73
8.6.1	Power Loss	73
8.6.2	Airflow and Noise Levels	75
8.7	Energy Efficiency Data	76
8.8	Packaging	77
8.9	Cable Length	80
8.10	EMC	81
8.10.1	EMC Compliance Levels	81
8.10.2	Emission Requirements	82
8.10.3	Immunity Requirements	83
<b>9</b>	<b>Exterior and Terminal Dimensions</b>	
9.1	Overview	84
9.2	IP20/UL Open Type Frames (FA02–FA12)	85
9.3	IP21/UL Type 1 Frames (FK06–FK12)	104
9.4	IP54/IP55/UL Type 12 Frames (FB09–FB12)	116
<b>10</b>	<b>Mechanical Installation Considerations</b>	
10.1	Contents of the Shipment	125
10.2	Product Labels	125

10.2.1	Overview	125
10.2.2	Product Labels on Drives	125
10.2.3	Package Labels	127
10.2.4	Product Labels on Functional Extensions	127
10.2.5	Product Labels on Control Panels	128
10.3	Disposal	129
10.3.1	Recommended Disposal	129
10.3.2	Real-time Clock Battery Disposal	129
10.4	Storage until Installation	129
10.4.1	Reforming the Capacitors	129
10.4.2	Safe Transportation and Storage	130
10.5	Prerequisites for Installation	131
10.5.1	Overview	131
10.5.2	Operating Environment	131
10.6	Derating for Operating Conditions	132
10.6.1	Overview of Derating for Operating Conditions	132
10.6.2	Derating for Ambient Temperature	132
10.6.3	Derating for Altitude	133
10.6.4	Derating for Output Frequency	134
10.6.5	Derating for Switching Frequency	134
10.7	Maintenance Considerations	136
10.7.1	Maintenance Considerations	136
10.7.2	Regular Maintenance	137
10.7.3	Maintenance Schedule	137
10.7.4	Service Access	137
10.7.5	Heat Sink and Fan Maintenance and Service	137
10.7.6	Backup Battery Exchange	138
10.8	Mechanical Installation	138
10.8.1	Overview	138
10.8.2	Mounting Considerations	139
10.8.3	Mounting Locations	139
10.8.4	Mounting Orientation	141
10.8.5	Recommended Fasteners	142
10.8.6	Drilling Patterns	143
10.8.7	Placement of the Drive in the Installation	145
10.8.8	Cooling	147

10.8.8.1 Overview of Cooling	147
10.8.8.2 Forced Air Cooling	147
10.8.8.3 Back-channel Cooling	148
10.8.9 Recommended Space for Service Access	149

## 11 Electrical Installation Considerations

11.1 Wiring Diagram	151
11.2 Grid Type and Protection	151
11.2.1 Grid Types	151
11.2.2 Currents on Protective Earth and Potential Equalization/Leakage Currents	152
11.2.3 PE Current Measurement	152
11.2.4 Residual Current Device (RCD) Protection	154
11.2.5 Isolation Monitoring Devices	154
11.3 EMC-compliant Installation Guidelines	155
11.3.1 EMC-compliant Installation Guidelines	155
11.3.2 Power Cables and Grounding	157
11.3.3 Control Cables	159
11.4 Motor Installation Considerations	159
11.4.1 Motor Installation Considerations	159
11.4.2 Supported Motor Types	160
11.4.3 Motor Insulation	160
11.4.4 Parallel Motors	160
11.4.5 Bearing Currents	161
11.4.6 Motor Thermal Protection	161
11.4.7 Electronic Thermal Relay Function	161
11.4.8 External Connected Sensors	162
11.5 Power Cable Considerations	162
11.5.1 Overview	162
11.5.2 Torque Requirements	162
11.6 Control Cable Connections	163
11.6.1 Overview	163
11.6.2 Functional Safety I/Os (X31, X32)	165
11.6.3 External 24 V Supply (X61)	165
11.6.4 Digital and Analog I/O (X11/X12)	166
11.6.5 Relay (X101/X102)	167
11.6.6 Communication Ports (X0, X1, X2)	167



11.6.7 Control Panel Connection (X8)	169
11.6.8 Functional Extension Options	170
11.6.9 Control Cable Connections	171
11.6.10 Control Wire Sizes and Stripping Lengths	171
11.6.11 Cable Shield Connection	172
11.7 STO Installation Considerations	173
<b>12 How to Order</b>	
12.1 Selecting the Frequency Converter	175
12.2 Model Code	175
12.2.1 Overview	175
12.2.2 Power Hardware	177
12.2.3 Optional Power Hardware (+Axxx)	178
12.2.4 Control Board Features (+Bxxx)	180
12.2.5 Functional Extension Options (+Cxxx)	180
12.2.6 Application Software and Additional Functionality (+Dxxx)	181
12.2.7 Customized Settings (+Exxx)	181
12.3 Ordering Filters and Braking Options	182
12.3.1 Harmonic Filters	182
12.3.1.1 Harmonic Filters Selection Guidelines	182
12.3.1.2 Advanced Harmonic Filter OF7P2, 380–415 V, 50 Hz Supply	182
12.3.1.3 Advanced Harmonic Filter OF7P2, 380–415 V, 60 Hz Supply	185
12.3.1.4 Advanced Harmonic Filter OF7P2, 440–480 V, 60 Hz Supply	188
12.3.1.5 IP21/UL Type 1 Kits and Backplates for Advanced Harmonic Filter OF7P2	190
12.3.2 Sine-wave Filters	191
12.3.2.1 Sine-wave Filters Selection Guidelines	191
12.3.2.2 Sine-wave Filter OF7S1	192
12.3.2.3 IP21/UL Type 1 Upgrade Kits for S1A02–S1A08 Sine-wave Filters	194
12.4 Ordering Options and Accessories	195
12.5 Ordering Self-service Parts	197



# 1 Introduction

## 1.1 Purpose of this Design Guide

This design guide is intended for qualified personnel, such as:

- Project and systems engineers.
- Design consultants.
- Application and product specialists.

The design guide provides technical information to understand the capabilities of the iC7 drives for integration into motor control and monitoring systems. Its purpose is to provide design considerations and planning data for integration of the drive into a system. It caters for selection of drives and options for a diversity of applications and installations. Reviewing the detailed product information in the design stage enables developing a well-conceived system with optimal functionality and efficiency.

This guide is targeted at a worldwide audience. Therefore, wherever occurring, both SI and imperial units are shown.

## 1.2 Intended Use

The drive is an electronic motor controller intended for:

- Regulation of motor speed in response to system feedback or to remote commands from external controllers. A power drive system consists of the AC drive, the motor, and equipment driven by the motor.
- System and motor status surveillance.

The drive can also be used for motor overload protection.

Depending on the configuration, the drive can be used in standalone applications or form part of a larger appliance or installation. The drive is allowed for use in residential, industrial, and commercial environments in accordance with local laws and standards.

### NOTICE

This product can cause radio interference.

- Supplementary mitigation measures can be required.

### NOTICE

#### FORESEEABLE MISUSE

- Do not use the drive in applications which are not compliant with specified operating conditions and environments. Ensure compliance with the conditions specified in *Ambient Conditions*.

### NOTICE

#### OUTPUT FREQUENCY LIMIT

- Due to export control regulations, the output frequency of the drive is limited to 590 Hz. For demands exceeding 590 Hz, contact Danfoss.

## 1.3 Additional Resources

Additional resources are available to help understand the features, and safely install and operate the iC7 products:

- Safety guides, which provide important safety information related to installing iC7 drives.
- Installation guides, which cover the mechanical and electrical installation of drives, or functional extension options.
- Operating guides, which include instructions for control options, and other components for the drive.

- Application guides, which provide instructions on setting up the drive for a specific end use. Application guides for application software packages also provide an overview of the parameters and value ranges for operating the drives, configuration examples with recommended parameter settings, and troubleshooting steps.
- *Facts Worth Knowing about AC Drives*, available for download on [www.danfoss.com](https://www.danfoss.com).
- Other supplemental publications, drawings, and guides are available at [www.danfoss.com](https://www.danfoss.com).

Latest versions of Danfoss product guides are available for download at <https://www.danfoss.com/en/service-and-support/documentation/>.

## 1.4 Planning and Design Support Materials

### 1.4.1 Overview

Danfoss provides access to comprehensive product information that supports throughout the product lifecycle.

All iC7 series design guides, installation guides, safety guides, operating guides, and application guides are available for download at <https://www.danfoss.com>. It is also possible to order printed guides.

For each iC7 drive or power converter, 2D and 3D drawings, and wiring diagrams are available in standard file formats. EPLAN files with macros, technical data, and 3D models are also provided to support in the system design.

Configuration files for drives or power converters are also available. MyDrive® Suite provides tools that support the entire lifecycle of the product, from system design to service. MyDrive® Suite is available at <https://suite.mydrive.danfoss.com/>.

The product configurator helps in the product selection, and when the process has been completed, the tool provides a list of relevant documentation and accessories.

Detailed product information can also be accessed by reading the 2D code on the product label.

### 1.4.2 Locating Support Information

Additional information is available on the company website.

1. Go to <https://www.danfoss.com>.
2. Select *Products*.
3. Select *Drives*.
4. Select the product series, for example *Low-voltage drives* or *System modules*.
5. Select the product series (for example, iC7).

 The browser opens the product page, which provides links to documents, drawings, and software of the product.

## 1.5 Version History

This guide is regularly reviewed and updated. All suggestions for improvement are welcome.

The original language of this guide is English.

**Table 1: Version History**

Version	Remarks
AJ319739940640, version 0501	Updated to include Fx08 frames.
AJ319739940640, version 0401	Updated to include frames Fx09–Fx12.
AJ319739940640, version 0301	Updated to include frames Fx06–Fx07.

**Table 1: Version History** (continued)

Version	Remarks
AJ319739940640, version 0201	Information regarding ecodesign and energy efficiency added. Minor updates throughout the guide.
AJ319739940640, version 0101	First release.

## 2 Safety

### 2.1 Safety

When designing AC drives, some residual dangers cannot be avoided. One example is the discharge time, which must be observed to avoid potential death or serious injury. The discharge time is shown on the danger label on the drive.

For further information on safety precautions related to the installation, operation, or maintenance of products, refer to the product-specific installation, safety, and operating guides.

### 2.2 Safety Symbols

The following symbols are used in Danfoss documentation.

#### DANGER

Indicates a hazardous situation which, if not avoided, will result in death or serious injury.

#### WARNING

Indicates a hazardous situation which, if not avoided, could result in death or serious injury.



#### CAUTION

Indicates a hazardous situation which, if not avoided, could result in minor or moderate injury.

#### NOTICE

Indicates information considered important, but not hazard-related (for example, messages relating to property damage).

The guide also includes ISO warning symbols related to hot surfaces and burn hazard, high voltage and electrical shock, and referring to the instructions.

	ISO warning symbol for hot surfaces and burn hazard
	ISO warning symbol for high voltage and electrical shock
	ISO action symbol for referring to the instructions

### 2.3 Medical Devices

#### WARNING

##### ELECTROMAGNETIC INTERFERENCE

AC drives and filters may produce electromagnetic interference up to 300 GHz that may affect the functionality of pacemakers and other implanted medical devices.

## 2.4 General Safety Considerations

When installing or operating the AC drive, pay attention to the safety information given in the instructions. For more information about safety guidelines for installation, refer to the product-specific safety guide. For more information about safety guidelines for operating the drive, refer to the product-specific guides.

The drive is not suitable as the only safety device in the system. Make sure that additional monitoring and protection devices on drives, motors, and accessories are installed according to the regional safety guidelines and accident prevention regulations.

### CAUTION

#### AUTOMATIC RESTART

The automatic restart function can cause danger.

- Before activating any automatic fault reset functions or changing limit values, make sure that no dangerous situations can occur after restart. If the auto reset function is activated, the motor starts automatically after an automatic fault reset.
- For more information on configuring automatic restart, refer to the application guide.

Keep all doors and covers closed and terminal boxes screwed on during operation of the drive and when mains is connected. Drive components and accessories can still be live and connected to mains, even after the operation indicators are no longer illuminated.

### WARNING



#### LACK OF SAFETY AWARENESS

This guide provides important information on preventing injury and damage to the equipment or the system. Ignoring this information can lead to death, serious injury, or severe damage to the equipment.

- Make sure to fully understand the dangers and safety measures present in the application.
- Before performing any electrical work on the drive, lock out and tag out all power sources to the drives.

### WARNING



#### HAZARDOUS VOLTAGE

AC drives contain hazardous voltage when connected to the AC mains or connected on the DC terminals. Failure to perform installation, start-up, and maintenance by qualified personnel can result in death or serious injury.

- Only qualified personnel must perform installation, start-up, and maintenance.

### WARNING



#### ELECTRIC SHOCK

- AC drives contain hazardous voltage when connected to AC mains, DC terminals, or motors. Failure to disconnect all power sources, including permanent magnet type motors and DC load sharing, can result in death or serious injury.

 **DANGER****SHOCK HAZARD FROM THE AC DRIVE**

Touching electrical parts of the drive can cause death or serious injury even after the equipment has been disconnected from AC power.

- Perform the following steps before touching any internal components:
  - Disconnect the mains power.
  - Disconnect the motor.
  - If there is a brake option, disconnect the brake.
  - If there is a load share or regen option, disconnect it. Wait for the capacitors to discharge fully.
  - Refer to the label on the drive for the correct discharge time.
  - Ensure that the DC-link capacitors have discharged fully by measuring the DC link with a voltage meter.

 **CAUTION****HOT SURFACES**

The drive contains metal components that are still hot even after the drive has been powered off. Failure to observe the high-temperature symbol (yellow triangle) on the drive can result in serious burns.

- Be aware that internal components, such as busbars, may be extremely hot even after the drive has been powered off.
- Do not touch exterior areas that are marked by the high-temperature symbol (yellow triangle). These areas are hot while the drive is in use and immediately after being powered off.

## 2.5 Qualified Personnel

To allow trouble-free and safe operation of the unit, only qualified personnel with proven skills are allowed to transport, store, assemble, install, program, commission, maintain, and decommission this equipment.

Persons with proven skills:

- Are qualified electrical engineers or persons who have received training from qualified electrical engineers and are suitably experienced to operate devices, systems, plants, and machinery in accordance with pertinent laws and regulations.
- Are familiar with the basic regulations concerning health and safety/accident prevention.
- Have read and understood the safety guidelines given in all guides provided with the unit, especially the instructions given in the operating guide of the drive.
- Have good knowledge of the generic and specialist standards applicable to the specific application.



## 3 Approvals and Certifications

### 3.1 Product Approvals and Certifications

iC7 product series complies with the required standards and directives. For detailed information on which approvals and certifications a product has, see the product label and <https://www.danfoss.com>.

Certificates and Declarations of Conformity are available on request or at <https://www.danfoss.com>.

Table 2: Approvals and Certifications Applicable to Drives







Approval	Description
	The drive complies with relevant directives and their related standards for the extended Single Market in the European Economic Area.
	The Underwriters Laboratory (UL) mark indicates the safety of products and their environmental claims based on standardized testing. Drives of voltage 525–690 V are UL-certified for only 525–600 V. The drive complies with UL 61800-5-1. For UL file number, see the product label.
	The drive complies with relevant regulation and their related standards for Great Britain. <b>UKCA contact information:</b> Danfoss, 22 Wycombe End, HP9 1NB, Great Britain
	The RCM Mark label indicates compliance with the applicable technical standards for Electromagnetic Compatibility (EMC). An RCM Mark label is required for placing electrical and electronic devices on the market in Australia and New Zealand. The RCM Mark regulatory arrangements only deal with conducted and radiated emission. For drives, the emission limits specified in EN/IEC 61800-3 apply. A declaration of conformity can be provided on request.
	The Korea Certification (KC) Mark indicates that the product conforms to relevant Korean standards.
	TÜV Süd certifies the functional safety of the drive in accordance to EN/IEC 61800-5-2. TÜV Süd tests products and monitors their production to ensure that companies stay compliant with their regulations.

Table 3: EU Directives Applicable to Drives

EU Directive	Description
Low Voltage Directive (2014/35/EU)	The aim of the Low Voltage Directive is to protect persons, domestic animals, and property against dangers caused by the electrical equipment, when operating electrical equipment that is installed and maintained correctly, in its intended application. The directive applies to all electrical equipment in the 50–1000 V AC and the 75–1500 V DC voltage ranges.
EMC Directive (2014/30/EU)	The purpose of the EMC (electromagnetic compatibility) Directive is to reduce electromagnetic interference and enhance the immunity of electrical equipment and installations. The basic protection requirement of the EMC Directive states that devices that generate electromagnetic interference (EMI), or whose operation could be affected by EMI, must be designed to limit the generation of electromagnetic interference and shall have a suitable degree of immunity to EMI when properly installed, maintained, and used as intended. Electrical equipment devices used alone or as part of a system must bear the CE mark. Systems do not require the CE mark, but must comply with the basic protection requirements of the EMC Directive.

Table 3: EU Directives Applicable to Drives (continued)

EU Directive	Description
Machinery Directive (2006/42/EC)	The aim of the Machinery Directive is to ensure personal safety and avoid property damage to mechanical equipment used in its intended application. The Machinery Directive applies to a machine consisting of an aggregate of interconnected components or devices of which at least 1 is capable of mechanical movement. Drives with an integrated functional safety function must comply with the Machinery Directive. Drives without a functional safety function do not fall under the Machinery Directive. If a drive is integrated into a machinery system, can provide information on safety aspects relating to the drive. When drives are used in machines with at least 1 moving part, the machine manufacturer must provide a declaration stating compliance with all relevant statutes and safety measures.
ErP Directive (2009/125/EC)	The ErP Directive is the European Ecodesign Directive for energy-related products. The directive sets ecodesign requirements for energy-related products, including drives, and aims at reducing the energy consumption and environmental impact of products by establishing minimum energy-efficiency standards.
RoHS Directive (2011/65/EU)	The Restriction of Hazardous Substances (RoHS) Directive is an EU directive that restricts the use of hazardous materials in the manufacturing of electronic and electrical products. Read more on <a href="http://www.danfoss.com">www.danfoss.com</a> .
Waste Electrical and Electronic Equipment Directive (2012/19/EU)	The Waste Electrical and Electronic Equipment Directive (WEEE Directive) sets collection, recycling and recovery targets for all types of electrical goods.

## 3.2 Standards

Installation must be in accordance with national regulations, for example NEC NFPA 70, or IEC 60364 series of standards.

The following standards are recommended as guidelines for the installation and operation of drives:

- **EN IEC 61800-2:2015 Adjustable speed electrical power drive systems - Part 2:** General requirements - Rating specifications for low voltage adjustable speed AC power drive systems.
- **IEC 61800-3:2022 Adjustable speed electrical power drive systems - Part 3:** EMC requirements and specific test methods.
- **EN IEC 61800-5-1:2017 Adjustable speed electrical power drive systems - Part 5-1:** Safety requirements - Electrical, thermal, and energy.
- **EN IEC 61800-9-2:2017 Adjustable speed electrical power drive systems - Part 9-2:** Ecodesign for power drive systems, motor starters, power electronics, and their driven applications - Energy efficiency indicators for power drive systems and motor starters.

Declarations of Conformity are available at [www.danfoss.com/en/service-and-support/documentation/](http://www.danfoss.com/en/service-and-support/documentation/).

## 3.3 Export Control Regulation

AC drives can be subject to regional and/or national export control regulations. Both the EU and US have regulations for so-called dual-use products (products for both military and non-military use), which currently includes AC drives with a capacity to operate from 600 Hz upwards. These products can still be sold, but it requires a set of measures, for example a license, or an end-user statement.

The US also has regulations for AC drives with a capacity to operate 300–600 Hz with restrictions on sales for certain countries. US regulations apply to all products manufactured in the US, exported from or via the US, or with a US content of more than 25%, or 10% for some countries. An ECCN number is used to classify all AC drives that are subject to export control regulations. The ECCN number is provided in the documentation accompanying the AC drive. If the AC drive is re-exported, it is the responsibility of the exporter to ensure compliance with the relevant export control regulations.

For further information, contact Danfoss.

## 4 Danfoss iC7 Series

### 4.1 Overview

The Danfoss iC7 comprises 3 products that combine hardware and software:

- iC7-Automation
- iC7-Hybrid
- iC7-Marine

The series consists of 3 hardware variants:

- Frequency converters
- Enclosed drives
- System modules

The drives have preinstalled application software matching the needs of the intended application. Alternative application software packages can be purchased, and some application software is only available for specific hardware variants. The application software packages available for iC7-Automation frequency converters are called **Industry** and **Motion**.

For detailed information about the application software available for frequency converters, refer to *iC7 Series Industry Application Guide* and *iC7 Series Motion Application Guide*.

### 4.2 Ecodesign for Power Drive Systems

#### 4.2.1 Overview

Energy-efficiency of the overall system is important and covered by the international standard IEC 61800-9-2. In some locations, such as the European Economic Area, compliance with minimum efficiency standards is regulated and legally required.

Frequency converters are classified by efficiency classes IE0 to IE2 according to IEC 61800-9-2. According to the standard, power losses are measured as percentages of the rated apparent output power at 8 load points as shown in [Figure 1](#).

Together with information about other elements of the system, this information can be used to calculate a system level efficiency (IES).

Elements causing losses are described in [4.2.2 Power Losses and Efficiency](#).

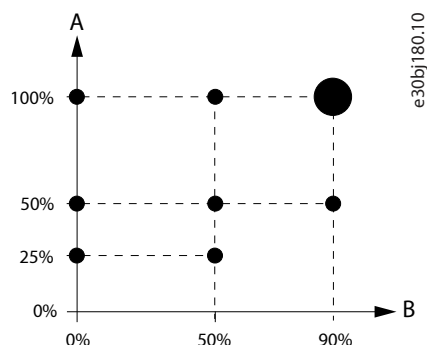

Figure 1: Operating Point According to IEC 61800-9-2

A	Relative torque producing current	B	Relative rated motor stator frequency
---	-----------------------------------	---	---------------------------------------

The frequency converter is labeled with the efficiency class and the power losses at 100% rated torque-producing current and 90% rated motor stator frequency.

[MyDrive® ecoSmart™](#) can be used to:

- Look up part load data as defined in IEC 61800-9-2.
- Calculate the efficiency class and part load efficiency for the frequency converter and the power drive system (systems consisting of a frequency converter, motor, and output filters).
- Create a report documenting part load loss data and IE and IES efficiency class.

## 4.2.2 Power Losses and Efficiency

Elements causing power loss in the system are shown in [Figure 2](#).

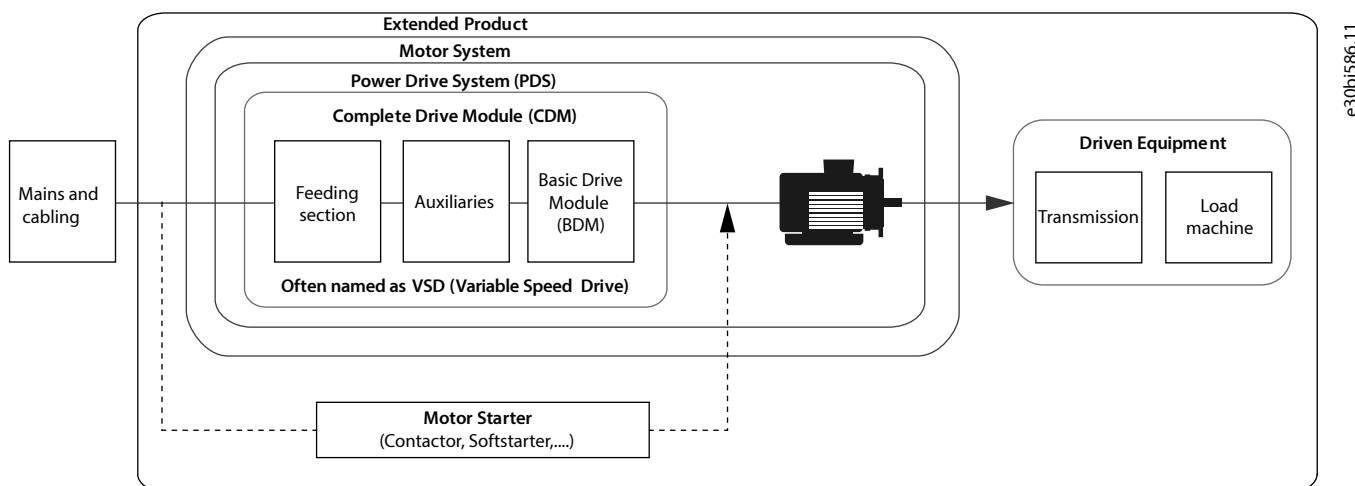

e30b1586.11

**Figure 2: Drive System Design**

The frequency converter itself only provides a part of the total losses of the system. The following components can cause losses in the system:

- Mains supply cable
- External input filter (optional)
- Frequency converter (including built-in filters)
- External output filter (optional)
- Motor cable
- Motor

Losses in the mains supply cable are mainly caused by the ohmic resistance of the cable. To keep the losses at a minimum, the cable length should be kept short and sized properly to the rated current.

Externally added input filters add to the losses in the system. Line reactors used to balance the phase load provide load-dependent losses of up to 1–2% of full power. Dedicated harmonic filters have losses of 2–5% of maximum power. Reducing harmonic distortion reduces the losses in the external cabling and transformers, resulting in lower system loss.

The loss of the frequency converter, also known as the basic drive module (BDM), is load-dependent. Specific classifications and power loss data are shown on the product label, and details can be seen in [MyDrive® ecoSmart™](#).

Specific information on the frequency converter can be found in [8.7 Energy Efficiency Data](#).

Externally connected output filters add losses to the system:

- Sine-wave filters suppress the pulse-width modulation (PWM) pattern of the output frequency, resulting in a sine wave output. The resulting loss is load-dependent and can be up to 1–1.5% of maximum power. Using a sine-wave filter in installations with long motor cables reduces cable loss.

- dU/dt filters increase the rise time of the PWM pattern, limiting du/dt. As a result, the filters introduce loss in the system. The loss is load-dependent and can be up to 0.5–1% of maximum power.
- Common-mode cores mitigate high-frequency noise in the motor cable. As a result, minor power loss is added to the system.

Losses in the motor cable are mainly caused by ohmic losses, but due to the switching frequency of the frequency converter, losses are also caused by capacitive coupling between phases and to ground. Losses due to capacitive coupling can be reduced by carefully selecting the motor cable and keeping the cable length as short as possible. If a sine-wave filter is used on the frequency converter output, the loss caused by capacitive load is reduced.

Motor losses depend on the motor type and efficiency category selected. IEC 60034-30-1 defines the different efficiency classes from IE1 to IE4.

## 5 iC7 Frequency Converters

### 5.1 Overview

The iC7 frequency converter is built as a modular, configurable drive, which can be complemented with functional extensions to match application needs. All options are configurable and can be selected when ordering the drive. Functional extensions, fieldbuses, and additional software can also be added later as a field upgrade.

The drive consists of a power unit, a control unit, and an application software package. In addition, a range of options and accessories are available. The available application software packages and features are described in chapter *iC7-Automation Application Software*.

### 5.2 Drive Models and Frame Designations

The iC7 frequency converters have a frame designation that indicates the characteristics of the products. The designations are used in this guide in illustrations and technical data, for example.

The frame designation consists of 4 or 5 characters, for example **FA04b**:

- The 1st character is fixed, and indicates that the hardware provides frequency converter functionality. For iC7 series frequency converters, F is used as the first character.
- The 2nd character indicates the protection rating:
  - A: IP20/UL
  - B: IP54/UL Type 12 or IP55/UL Type 12
  - K: IP21/UL Type 1
- The 3rd and 4th characters are a running number 02–12. The number is linked to a specific frame of the product, which is used, for example, in the current rating tables.
- The 5th character is optional, and is only for frames that have specific variants and therefore different dimensions:
  - a: Standard depth and height
  - b: Extended depth
  - c: Extended height

The dimensions of each frame type are given in chapter *Exterior and Terminal Dimensions*.

Examples of frame designations used in this guide:

- Frame designation FA04b translates into an IP20/UL Open Type frame 04 with extended depth.
- Frame designation FK06 translates into an IP21/UL Type 1 frame 06.
- If the reference in an illustration, text, or table applies to all variants, the 2nd character is replaced with an x, for example Fx06, indicating FA06, FB06, and FK06.
- If the reference is to all variants of a specific rating, the reference is described with the first 2 characters only, for example FA indicating all frames from FA02 to FA12 with the IP20/UL Open Type protection rating.

### 5.3 Power Unit

The drives are designed to fit a wide variety of installation locations, and are available in different protection ratings, making them suitable for installation in cabinets, directly on machines, in dedicated control rooms and freely installed.

- IP20/UL Open Type frames are designed for installation in enclosed cabinets and similar setups.
- IP21/UL Type 1 frames are designed for indoor installations.
- IP54/IP55/UL Type 12 frames are designed for use in environments where the drive is exposed to both dust and water.

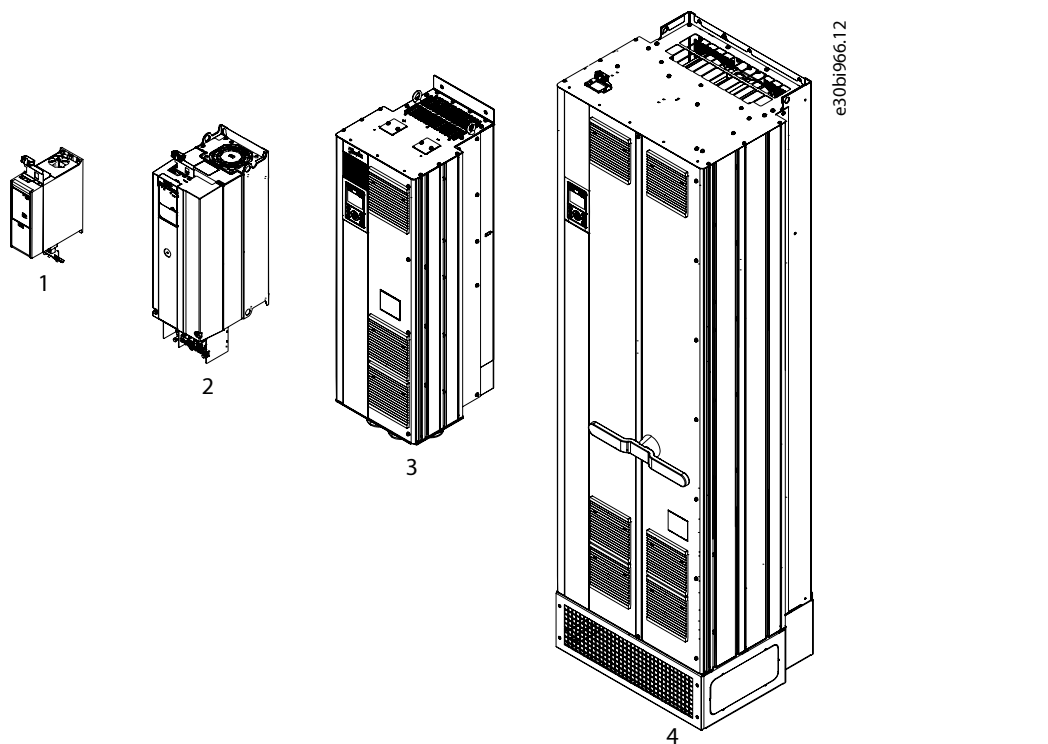

1	IP20/UL Open Type, FA02	2	IP20/UL Open Type, FA06
3	IP21/UL Type 1, FK09	4	IP54/IP55/UL Type 12, FB11

**Figure 3: Frame Offering in the iC7-Automation Range**

The frame variants are identified by a 4–5 character designation, where the first 2 characters indicate the protection rating, and the remaining characters indicate physical dimensions of the frame. For details on the characters in the frame designation, see [5.2 Drive Models and Frame Designations](#).

The drives are suitable for use in a wide temperature range. The standard operating temperature range is from  $-30\text{ }^{\circ}\text{C}$  to  $+50\text{ }^{\circ}\text{C}$  ( $-22\text{ }^{\circ}\text{F}$  to  $+122\text{ }^{\circ}\text{F}$ ). With derating, the maximum operating temperature is increased to  $60\text{ }^{\circ}\text{C}$  ( $140\text{ }^{\circ}\text{F}$ ). For more information on derating, see [10.6.1 Overview of Derating for Operating Conditions](#).

The drives are designed for operation in altitudes up to 4400 m (14400 ft). Derating should be considered for altitudes above 1000 m (3280 ft).

IP20/UL Open Type frames (up to 43 A, 400 V) have pluggable power connectors to make installation and service exchange easy. The motor output is protected against short circuit, ground fault, and overload. Thermal monitoring is also provided to protect the motor. Unlimited switching on output enables using a contactor or disconnects between the drive and the motor. The drives can operate motors connected in parallel.

Drives rated for 206 A and up (Fx09–Fx12, 400 V) use back-channel cooling, where cooling air is ducted out from the cabinets or cooling rooms, reducing the need for extra cooling. Heat pipe technology is applied in heat sinks in frames Fx09–Fx12.

Integrated filters optimize EMC performance, reduce harmonics on the grid, and match with output requirements:

- Built-in EMC filters can be configured to fit the EMC-related installation requirements. The offering covers drives without filter, filters for use in industrial networks (C3 and C2 compliant variants) and filters compliant to domestic installations (C1 compliant). The maximum motor cable length for installations is 300 m (984 ft). For details on cable lengths, see [8.9 Cable Length](#).
- All drives have a built-in DC-link filter, which reduces the harmonic distortion on the grid.



- External dU/dt filters, sine-wave filters, harmonic filters, and common-mode HF filters are available as optional accessories. For more information about the filters, see chapter *Filters and Braking Options*.

## 5.4 Power Unit Options

The product architecture allows adding configurable hardware options, which increase the robustness of the installation:

- A brake chopper improves braking performance, dissipating excess energy in a connected brake resistor. For units in frames up to 43 A (FA02–FA05, 400 V), the brake chopper is integrated as standard.
- DC terminals allow a common connection of the DC capacitor banks of multiple drives, which enables sharing of excess energy during operation. For details, see *Use of DC Connections in iC7-Automation Frequency Converters Application Guide*. Frames up to 43 A (FA02–FA05, 400 V) have the DC terminals available as standard.
- An optional mains switch allows for the manual disconnect of mains power, which increases safety during service. The mains switch is interlocked with the cabinet cover or door to prevent them from being opened while power is still applied. If the mains switch is selected when ordering a drive, it is preinstalled in the drive.
- Optional built-in fuses that offer extra protection against failures inside the drive are available for IP21 and IP54/IP55 drives.
- An optional touch protection in front of the power terminals adds extra protection against accidental contact when the enclosure door is open. If the touch protection option is selected when ordering frames FK09–FK12 and FB09–FB12, it is preinstalled in the drive from the factory. Touch protection kits can also be ordered as an accessory and installed as a field upgrade.
- The drives are designed to meet the typical conditions for indoor installation and use. If the drive is exposed to harsher environments, coated printed circuit boards can be selected to have more protection against the environment. Drives from 206 A (Fx09–Fx12, 400 V) have coated printed circuit boards as a standard option.
- A heat sink access panel is available for drives in the range from 206 A and up (Fx09–Fx12, 400 V) and allows easy access to clean the heat sink fins in the cooling channel.

## 5.5 Control Unit and Interfaces

### 5.5.1 Control Unit and Interfaces

The drive has an integrated control unit, which consists of a control board with integrated functional safety, integrated Ethernet ports, option slots for additional option boards, and a control panel. See [Figure 4](#) for an illustration of the control unit mechanics.

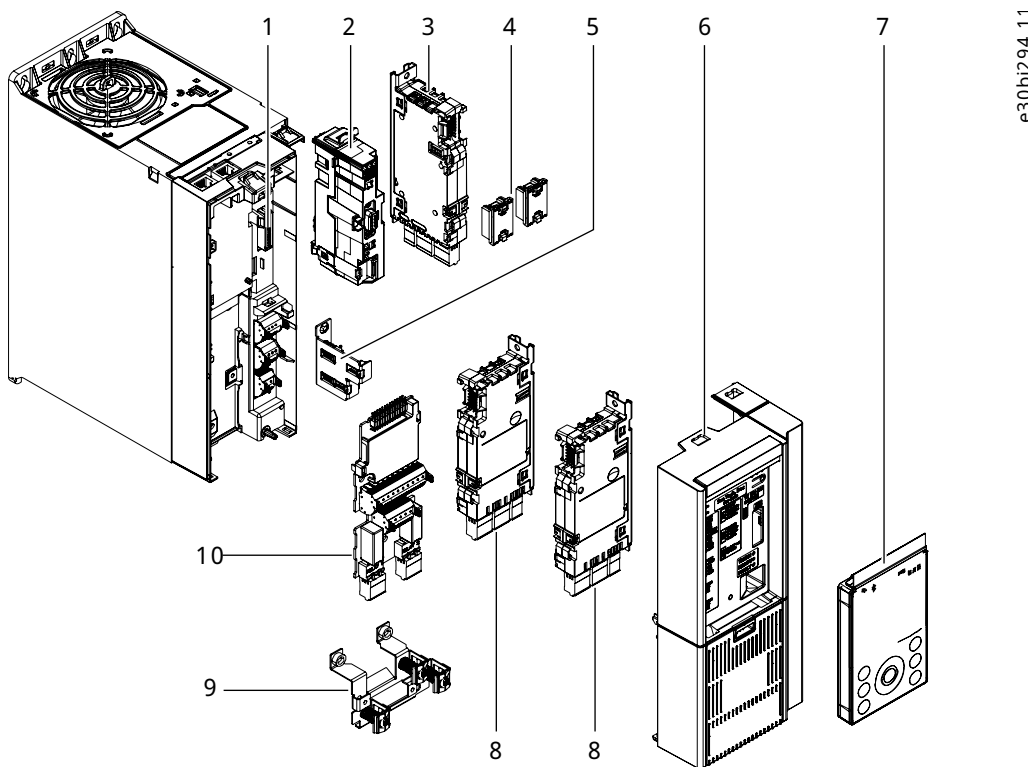

1	Control board	2	Interface board
3	Option placed in slot C	4	Option connectors
5	EMC plate	6	Terminal cover
7	Control panel	8	Options placed in slots A and B
9	EMC plate	10	Basic I/O board

**Figure 4: Control Unit Mechanics**

iC7-Automation is delivered with the **Industry** application software package. Optional applications can be included from the factory or added later with a proof-of-purchase token.

### 5.5.2 Control Board and Standard I/O

The control board concept offers a high level of flexibility in use due to its scalability, protects the setup and operation of the drive, and is easy to connect because of the pluggable terminals.

- **Increased security:** Integrated crypto-chip-based security features in the drive protect against unauthorized changes to the settings and software of the drive.
- **Memory card reader:** The microSD card reader enables software upgrades, data logging, or copying settings from one drive to another drive. Data is protected by the security features of the drive.
- **Pluggable control terminals:** The terminals are pluggable and allow bridging of control wires.
- **PELV (galvanic) isolated control terminals:** All control terminals and output relay terminals are galvanically isolated from mains power. The isolation meets the protective extra-low voltage (PELV) requirements for isolation.
- **Integrated functional safety (SIL 3):** The control board provides the Safe Torque Off (STO) safety function with a dual-channel, galvanically isolated input up to PL e and SIL 3 and an STO feedback signal for diagnostic purposes.
- **Flexible basic I/O:** The optional basic I/O board adds 4 digital inputs, 2 combined digital inputs/outputs, 2 analog inputs, 1 analog output, and 2 relay outputs to extend the connectivity of the drive. More I/O options can be added in up to 4 option slots. The

options offer added functionality such as relays, digital and analog I/O, encoder/resolver support, temperature measurement, and functional safety I/O.

- 24 V DC external supply: The drive is fitted with the possibility to connect an external 24 V DC supply to the control board to allow continued operation of fieldbus and control programs, when mains power is switched off.

### 5.5.3 Communication Interfaces

The drives have built-in communication ports:

- Ethernet ports X1 and X2 allow connections to fieldbus systems, with support for daisy chaining and single connections. The selected protocol comes preconfigured from the factory. Modbus TCP is offered as standard, and other protocols such as PROFINET RT and EtherNet/IP are available either preinstalled from the factory, or alternatively, they can be activated later with a proof-of-purchase token. Safe Fieldbus protocols are also supported.
- Ethernet port X0 is available to connect to a PC or similar tools used for commissioning or service.

### 5.5.4 Control Panels

The iC7 series offers a broad range of interfaces showing simple status readouts over wireless communication to advanced user interfaces giving access to drive parameters and settings.

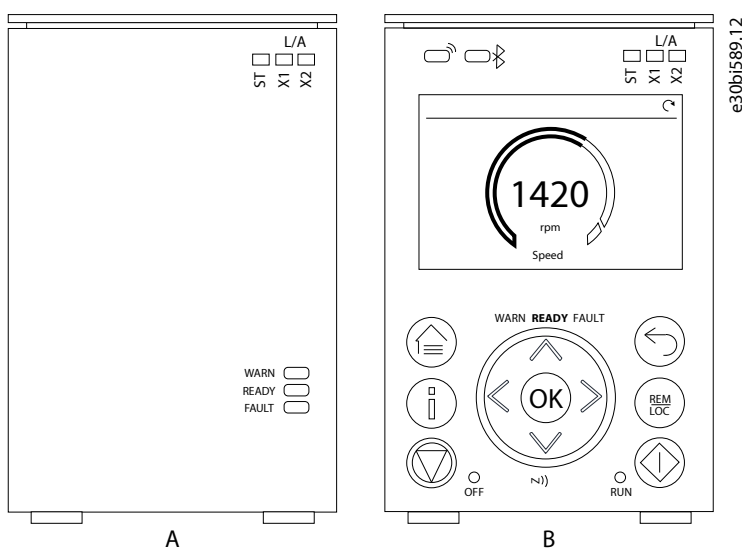

Figure 5: Control Panel Options

- **Blind Panel OPX00:** The Blind Panel has indicators showing the status of the drive and the fieldbus connection. It is typically used when limited interaction is required with the drive after installation and commissioning, or when the drives are controlled by fieldbus.
- **Control Panel 2.8 OPX20:** The Control Panel 2.8 is typically used when regular interaction with the drive is expected. The Control Panel 2.8 has the basic status and fieldbus indicators, a 2.8 inch graphical display, and tactile feedback buttons. The halo around the navigation buttons indicates the drive status and is visible from a long distance.

Mounting kits are available for external mounting of control panels. For more information, see [7.5.4 Control Panel Mounting Kits and Cables](#).

### 5.5.5 Functional Safety

The drive offers a scalable setup of the functional safety features.

A galvanic isolated, dual channel Safe Torque Off (SIL 3, PL e) input is offered as standard in the drive. It also contains an STO feedback output that can be used as a status signal, or as a diagnostic signal to external safety equipment. This version of functional safety cannot be upgraded in the field.

It is also possible to select a functional safety option with STO, SS1-t, and safe fieldbus support. This option includes a configurable dual channel input and supports both STO and time-based Safe Stop 1 (SS1-t). Safe fieldbuses are also supported.

For more details on ordering functional safety options, see [12.2.4 Control Board Features \(+Bxxx\)](#).

## 5.6 Overload Capability

### 5.6.1 Load Profile Overview

When selecting a drive, it is important to know the load characteristic and load cycle of the application to ensure optimal performance.

The output current rating is selected based on the application load profile. In addition, derating of the output current may be needed, for example, if operational temperature is increased, or the drive is installed in an altitude above 1000 m (3300 ft). For more information on derating, see [10.6.1 Overview of Derating for Operating Conditions](#).

iC7 drives are rated with 3 output current categories:

- **Low overload (LO):** 110% load for a minimum of 1 min every 10 min
- **High overload (HO1):** Up to 160% load for 1 min every 10 min, with a break-away torque of up to 200%
- **High overload with increased duty (HO2):** Up to 160% load for 1 min every 5 min and with a break-away torque of up to 200% in the startup of the process

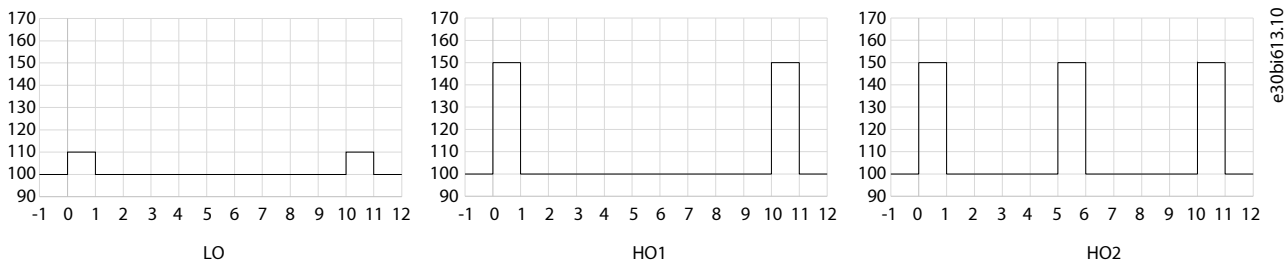

Figure 6: Low Overload, High Overload, and High Overload with Increased Duty Curves

For the startup of motors, a short time break-away torque can be applied for 3 s. The rating depends on setting and actual current rating.

For ratings of the drives at rated voltage and frequency, see [8.2.2 Ratings for Frequency Converters with 380–500 V Supply Voltage](#).

MyDrive® Select can also be used to support the selection, including calculations and optimizations, of the drive.

### 5.6.2 Low Overload (LO)

The low overload profile supports applications running at a non-varying or slowly varying load, where a limited overload capability is required. It is typically used in applications with a variable torque load.

The low overload profile allows the drive to run at **110% load for a minimum of 1 min every 10 min**.

Typical applications where the low overload profile is used are:

- Fans
- Centrifugal pumps
- Blowers and aerators
- Screw compressors

### 5.6.3 High Overload (HO1)

The high overload profile is typical for applications which require higher short-term overload and constant torque operations. The typical applications for the high overload profile are with continuous motion.

For drives up to Fx08, the HO1 nominal output is rated at the same level as for low overload. For Fx09–Fx12, the output rating is defined for 1 motor size down compared to the low overload profile.

With the high overload profile, the drive is able to run with a load of **up to 160% for 1 min every 10 min, with a break-away torque of up to 200%**, depending on size. For drive-specific data, see [8.2.2 Ratings for Frequency Converters with 380–500 V Supply Voltage](#).

Typical applications where the high overload profile is used are:

- Conveyors
- Centrifuges
- Decanters
- Piston compressors
- Piston pumps
- Mixers
- Stirrers
- Escalators
- Extruders (continuous running)

#### 5.6.4 High Overload with Increased Duty (HO2)

The high overload with increased duty profile is used when the application has intermittent or continuous periodic duty. The resulting cyclic load requires more considerations on the use of the drive to ensure necessary performance and lifetime. Increased short-term starting torque is often also required.

To benefit from the increased dynamic performance and not compromising lifetime, the output current is downrated by 1 motor size compared to the HO1 rating.

With the high overload profile with increased duty, the drive can run with **up to 160% load for 1 min every 5 min, with a break-away torque of up to 200%**, depending on the current rating.

Typical applications where the high overload profile with increased duty is used are:

- Extruders
- Continuously accelerating conveyors
- Lifts and hoists
- Cranes
- Positioning applications
- Dosing pumps

## 6 iC7-Automation Application Software

### 6.1 Overview

The iC7 drives provide precision motor control and are equipped with integrated functional safety, security, and connectivity features.

The two application software packages available for iC7-Automation frequency converters are:

- The Industry application is included as standard in iC7-Automation drives, unless another application has been selected when ordering the drive. The Industry application software offers speed and torque control combined with a wide range of features to support various demanding applications.
- The Motion application offers the same range of motor control principles as the Industry application software, and adds positioning and synchronization capabilities. The Motion application can be selected when ordering the drive, or later as a field upgrade.

For more information on the features and how to configure them, see the *iC7 Series Industry application guide* and *iC7 Series Motion application guide*.

### 6.2 Basic Functions

#### 6.2.1 Overview of Basic Functions

The basic functions of the iC7 Series Industry application software include reference handling, I/O control and readouts, and mechanical brake control, among many others. This section briefly describes the basic functions which enable the drive to control any application.

#### 6.2.2 I/O Control and Readouts

Depending on the hardware configuration of the drive, digital and analog inputs as well as digital, analog, and relay outputs are available. The I/Os can be configured and used to control the application from the drive.

If functional extension options are installed in the drive, the relevant parameters and I/O selections are automatically visible in the parameter structure.

#### 6.2.3 Reference Handling

References from multiple sources can be defined, depending on the needs of the application.

Reference sources are:

- Analog inputs
- Digital inputs either as pulse input or digital potentiometer
- Reference from a fieldbus
- Up to 8 preset references (selectable by parameter, fieldbus, or digital inputs)
- Local reference from control panel

Reference signals can be added, subtracted, and multiplied, generating the reference to the drive. The final reference is scaled from -100% to 100%.

#### 6.2.4 Ramps

Linear and S-ramps are supported. Linear ramps provide a constant acceleration and deceleration. S-ramps provide a non-linear acceleration and deceleration, with a soft transition at the start and end of the acceleration and deceleration process.

#### 6.2.5 Quick Stop

In some situations, it may be required to stop the application quickly. For this purpose, the drive supports a specific deceleration ramp time from the synchronous motor speed to 0 RPM.

### 6.2.6 Limit Rotation Direction

The motor can be preset to run in one rotational direction only (positive or negative), avoiding unintended rotation direction.

### 6.2.7 Inching with Jogging Modes

Predefined speed settings are available for use during commissioning, maintenance, or service. The settings include Slow Down mode (operating at decreased speed), Jogging mode (operating at a preset speed), and Override mode (this mode overrides any reference settings).

### 6.2.8 Speed Bypass

Specific motor speeds can be bypassed during operation. The feature helps to minimize or avoid mechanical resonance of the machine, limiting the vibration and noise of the system.

### 6.2.9 Flying Start

Flying start enables the drive to synchronize to a freely spinning motor, before taking control of the motor. Taking over control of the motor at the actual speed minimizes mechanical stress to the system. This feature is relevant in fan and centrifuge applications, for example.

### 6.2.10 Mains Dropout

If there is a mains dropout and the drive cannot continue operation, it is possible to select predefined corrective actions. These actions include a trip, coasting, or performing a controlled ramp down.

### 6.2.11 Kinetic Backup

Kinetic backup enables the drive to remain in control if there is sufficient energy in the system, as inertia or when lowering a load, for example. The function allows a controlled stop of the machine.

### 6.2.12 Resonance Damping

High-frequency motor resonance noise can be eliminated by using resonance damping. Both automatic and manually selected frequency damping is available.

### 6.2.13 Motor Preheating

In cold and damp environments, the motor must be preheated to avoid condensation and cold starts. The feature DC Start generates a small DC current through the motor windings, keeping the temperature above the surrounding temperature.

### 6.2.14 Mechanical Brake Control

In applications like cranes, lifts and hoists, or downhill conveyors, a mechanical brake is used to keep the load at standstill when the motor is not controlled by the drive or when power is turned off.

The mechanical brake control feature ensures a smooth transition between the mechanical brake and the motor holding the load, by controlling the activation and deactivation of the mechanical brake.

### 6.2.15 Load Drooping

The load drooping function ensures that multiple motors, each controlled by a drive and connected to a common mechanical shaft, share the load. The function is typically used in cranes, winches, or larger conveyor systems controlled by 2 or more motors.

## 6.3 Controllers

### 6.3.1 Overview

Speed and torque control are included in both Industry and Motion application software. In addition to the common control features, each application software has an extra control feature to meet the needs of the application.

**Table 4: Control Features in iC7-Automation Application Software**

Feature	Industry	Motion
Speed control	x	x
Torque control	x	x
Process control	x	–
Position control	–	x

### 6.3.2 Speed Controller

A built-in speed PID controller provides accurate control of the rotational speed of the motor. The controller offers control in both open and closed-loop configuration.

Open-loop mode does not require an external sensor for measuring the feedback signal. This allows easy installation and commissioning and eliminates the risk of defective sensors.

In closed-loop mode, a speed sensor is added, offering highly accurate control.

The parameters of the speed controller can be optimized by the built-in **auto tuning** function.

### 6.3.3 Torque Controller

A built-in torque controller provides optimized control of torque. Typical use cases are in tension control for winches or extruders. The drive offers both open-loop control where the current sensors provide the feedback and a closed-loop control with feedback provided by an external torque sensor.

### 6.3.4 Process Control

The process controller can control a process in a system where a constant pressure, flow, or temperature is needed, for example. Feedback from the application is connected to the drive, providing the actual process value. By controlling the motor speed, the controller ensures that the output matches the reference provided. The reference source and the feedback signals are converted and scaled to the actual values controlled. The controller provides full PID control, which includes PID parameter configuration, and is optimized by the built-in auto-tuning function.

### 6.3.5 Position Controller

A built-in position controller provides accurate position control of linear or rotating movement. Position control is always closed loop, based on a PID controller, but the position feedback can be:

- The position measured by a physical device, for example an encoder
- The rotor position estimated by Motor Control, referred to as "sensorless position control"

This position controller is the basis for the integrated motion control features like Positioning and Gear mode.



## 6.4 Motor Control Features

### 6.4.1 Motor Types

The drive supports standard available motors, such as:

- Asynchronous motors
- Permanent magnet motors
- Synchronous reluctance motors

### 6.4.2 Torque Characteristics

Different load characteristics are supported to match the actual application needs:

- **Variable torque:** Typical load characteristic of fans and centrifugal pumps, where the load is proportional to the square of the speed.
- **Constant torque:** Load characteristic used in machinery where torque is needed across the full speed range. Typical applications are conveyors, extruders, decanters, compressors, and winches.

### 6.4.3 Motor Control Principles

Different control principles can be selected to control the motor, matching the needs of the application:

- U/f control for simple open-loop operation.
- VVC+ (Voltage Vector Control) in both open and closed loop, for general-purpose application needs.
- FVC+ (Flux Vector Control) in both open and closed loop, for demanding application needs.

### 6.4.4 Motor Nameplate Data

Typical motor data for the drive are preset at the factory. The preset data allow operation of most motors. During commissioning, actual motor data are entered in the settings of the drive to optimize motor control.

### 6.4.5 Automatic Motor Adaptation (AMA)

Automatic Motor Adaptation (AMA) optimizes motor parameters for improved shaft performance. Based on motor product label data and measurements of the motor at standstill, key motor parameters are recalculated, and used to fine-tune the motor control algorithm.

### 6.4.6 Automation Energy Optimization (AEO)

The Automatic Energy Optimization (AEO) feature optimizes control with focus on lowering energy consumption at the actual load point.

### 6.4.7 Braking of Load

#### 6.4.7.1 Overview of Braking of Load

For controlled load braking performed by the drive, various functions can be used. The specific function is selected based on the application and how fast the load has to be stopped.

#### 6.4.7.2 Resistor Braking

In applications that require fast or continuous braking, a drive fitted with a brake chopper is typically used. Excess energy, generated by the motor during the braking of the application, is dissipated in a connected brake resistor. Braking performance depends on the specific drive rating and the selected brake resistor.

#### 6.4.7.3 Overvoltage Control (OVC)

If braking time is not critical or the load is varying, the overvoltage control (OVC) feature can be used to control the stopping of the application. The drive extends the ramp-down time when it is not possible to brake within the defined ramp-down period. This feature must not be used in hoisting applications, high inertia systems, or applications where continuous braking is required.

#### 6.4.7.4 DC Brake

When braking at low speed, the braking of the motor can be improved by using the DC brake feature. The software offers configurable DC-braking for induction motor control. It injects a user-defined DC current.

#### 6.4.7.5 AC Brake

In applications where the operation of the motor is non-cyclic, AC braking can be used to shorten the braking time. Excess energy is dissipated by increasing losses in the motor during braking. Performance is motor type dependent and offers best performance on asynchronous motors.

#### 6.4.7.6 DC Hold

The software offers the possibility to configure the feature DC Start for DC holding before entering normal motor control.

#### 6.4.7.7 Load Sharing

In some applications, 2 or more drives control the application at the same time. If 1 of the drives is braking a motor, the excess energy can be fed to the DC link of a drive driving a motor, which results in a reduction of the total energy consumption. This feature is typically useful in, for example, decanters and carding machines, where smaller power-sized drives operate in generator mode.

### 6.5 Protection Features

#### 6.5.1 Motor Protection Features

The drive provides various features to protect the motor and the application.

The output current measurement provides information to protect the motor. Overcurrent, short circuit, ground faults, and lost motor phase connections can be detected and relevant protections initiated.

Monitoring of speed, current, and torque limits provides an extra protection of the motor and the application. Under extreme load conditions, it also provides motor stall protection.

Locked-rotor protection secures that the drive is not starting with a blocked rotor of the motor.

Motor thermal protection is provided either as a calculation of the motor temperature based on the actual load, or by external temperature sensors connected to Temperature Measurement OC7T0. Supported sensor types are Pt100, Pt1000, Ni1000, KTY84, and KTY81.

#### 6.5.2 Grid Protection

The drive protects against conditions in the power grid that can affect proper operation. The grid is monitored for phase imbalance and phase loss. When the imbalance exceeds specified limits, the drive issues a configurable response and corrective actions can be taken.

The supply frequency is also monitored, and when the drive is outside acceptable limits, it reacts in the configured way. Furthermore, the software of the drive offers optional protection against undervoltage and a configurable response to grid spikes.

#### 6.5.3 Drive Protection Features

The drive is monitored and protected during operation.

Inbuilt temperature sensors measure the actual temperature and provide relevant information to protect the drive. If the temperature exceeds its nominal temperature conditions, derating of operational parameters is applied. If the temperature is outside the allowed operating range, the drive stops operation.

The motor current is continuously monitored on all 3 phases. If there is a short circuit between 2 phases, or a fault to ground, the drive detects the short circuit and immediately turns off. If the output current is exceeding its nominal values during operation for longer periods than allowed, the overload capability is reduced until the conditions are restored.

The DC-link voltage of the drive is monitored. If it exceeds critical levels, the drive issues a warning. If the situation is not resolved, the drive stops operation.

#### 6.5.4 Protection of External Filters or Brake Resistors

Brake resistors are monitored for thermal overload (by calculated thermal load or an external sensor), short circuit, and missing connections.

The drive can also monitor the temperature of externally connected filters.

#### 6.5.5 Automatic Derating

Automatic derating of the drive allows continued operation even if the nominal operation conditions are exceeded. Typical factors affecting operation are temperature, high DC-link voltage, high motor load, or operation close to 0 Hz. Derating is typically applied as a reduction in switching frequency or change in switching pattern, resulting in lower thermal losses.

### 6.6 Monitoring Features

#### 6.6.1 Monitoring Features

The drive offers a wide range of monitoring features that provide information of actual operating conditions. Some examples are:

##### Speed monitoring

The motor speed can be monitored during operation. If the speed exceeds minimum or maximum limits, the user is notified and can initiate appropriate actions.

##### Temperature monitoring

Temperatures of the drive and external connected sensors can be monitored. This way you can monitor the operational conditions of the drive and the related application.

##### Grid monitoring

During operation, the drive is able to monitor the grid conditions. It measures the grid voltage for each supply phase and the grid frequency, and calculates the grid voltage imbalance and total harmonic distortion (THDv).

#### 6.6.2 Event Log

An event log provides access to the latest registered warnings and faults, providing relevant information for analysis of the events that occur in the drive.

#### 6.6.3 Logging and Storage of Data

Logging of operational data from the drive and the related process is possible during running. Logging can be continuous or triggered by specific events. Data is stored to the microSD card placed in the drive, or transferred directly to MyDrive Insight. This feature provides the opportunity to collect data for a detailed analysis of operation and the events happening during operation.

#### 6.6.4 Preventive Maintenance

Elements in the application must be inspected and serviced periodically because of wear and tear during operation. For example motor bearings, feedback sensors, seals, and filters are subject to wear and must be serviced or replaced. With preventive maintenance, the service intervals can be programmed into the drive. The drive issues a warning when maintenance is required.

10 preventive maintenance items can be programmed into the drive. The following information must be specified for each item:

- The type of the trigger that activates the maintenance (for example Running hours)
- Maintenance interval (for example 1000 hours)

The parameters can also be set individually via fieldbus.

## 6.7 Functional Safety

A Safe Torque Off function with dual input is available as standard in the drive. An additional Safe Torque Off feedback signal indicates the status of the drive.

More functional safety features are available as optional selections. The set of features covers a wide range of functional safety functions that can operate in both sensorless and closed-loop setup. A safe fieldbus is also supported as option.

## 6.8 Security Features

### NOTICE

Do not connect the drive directly to the internet, as end-to-end connectivity is not secured via Danfoss software tools. It is recommended that drives are installed by authorized and educated personnel, who are aware of the security risks in networks and can mitigate threats in the network. Typically, the drive can be accessed and configured by anyone with physical access.

The drive provides the following cybersecurity features:

- Secure boot chain
- Signed and encrypted firmware and application software
- Secure software updates
- License verification
- Secure connectivity for all communication interfaces

## 6.9 Motion Application Software Features

### 6.9.1 Position Control

Motion application software supports multiple configurations for motor, speed, and position control, with and without feedback enabling adaptation to most applications.

### 6.9.2 Positioning Mode

The iC7 drives offer 3 basic positioning types:

- Absolute positioning
- Relative positioning
- Touch probe positioning

The difference between the positioning types is the reference point that is used for the positioning target.

### 6.9.3 Gear Mode

In Gear mode, the drive is position-controlled. The target position is given by a master signal taking the gear ratio into account, thus synchronizing the movement of the follower to the master and forming an electronic shaft.

### 6.9.4 Homing

The Homing function is used to define the zero point of the machine, thus creating a relation between the physical position of the machine and position values registered by the drive. Homing is needed in different situations depending on the operating mode and type of feedback.

## 6.9.5 Touch Probe

The Touch probe function captures the actual position at the edge of a signal on a digital input, independent of the operating mode. 2 simultaneous touch probes are supported, called Touch Probe 1 and Touch Probe 2.

## 6.9.6 Superimposed Movement

Superimposed movement is positioning on top of an underlying motion in Speed mode or Gear mode, used for offsetting the position while running. Superimposed movement is controlled by a separate profile generator, which calculates a speed profile on top of the underlying movement based on distance, speed, and ramps.

## 6.10 Software Tools

### 6.10.1 Overview of Software Tools

Danfoss offers a suite of desktop software tools which have been designed to provide easy operation and the highest level of customization of AC drives.

APIs and the Danfoss Device Interface make it possible to integrate the tools into proprietary systems and business processes. The MyDrive® tools support the entire life cycle of the drive, from system design to service. Some of the tools are available free of charge, and some require a subscription.

For more information about the MyDrive® tools, see MyDrive documentation.

### 6.10.2 MyDrive® Select

MyDrive® Select performs frequency converter sizing based on calculated motor load currents, ambient temperature, and current limitations. The sizing results are available in graphical and numerical format, and include calculations of efficiency, power losses, and inverter load currents. The resulting documentation is available in .pdf or .xls format, and can be imported to MyDrive® Harmonics for evaluation of the harmonic distortion, or validation of compliance towards most recognized harmonic norms and recommendations.

MyDrive® Select is available as a web-based tool at [select.mydrive.danfoss.com](https://select.mydrive.danfoss.com) and as a mobile device app that can be downloaded from app stores.

### 6.10.3 MyDrive® Harmonics

MyDrive® Harmonics estimates the benefits of adding harmonic mitigation solutions to an installation and calculates system harmonic distortion. The evaluation can be done both for new installations and when extending an existing installation.

The free version provides a fast overview of the expected general performance of the system. The expert version of MyDrive® Harmonics requires a subscription, which opens up more features, including the possibility to save and share harmonic projects, import projects from MyDrive® Select, and the possibility to add Danfoss harmonic mitigation products.

MyDrive® is available as a web-based tool at <https://harmonics.mydrive.danfoss.com>.

### 6.10.4 MyDrive® ecoSmart™

MyDrive® ecoSmart™ determines the energy efficiency of the drive being used and the system efficiency class according to IEC 61800-9.

MyDrive® ecoSmart™ uses information about the selected motor, load points, and AC drive to calculate the efficiency class and part load efficiency for a Danfoss AC drive, either for a free-standing drive (CDM), or a drive with a motor (PDS).

MyDrive® ecoSmart™ is available as a web-based tool at [ecosmart.mydrive.danfoss.com](https://ecosmart.mydrive.danfoss.com) and as a mobile device app that can be downloaded from app stores.

### 6.10.5 MyDrive® Insight

MyDrive® Insight is a software tool for commissioning, engineering, and monitoring drives. MyDrive® Insight can be used to configure parameters, upgrade software, and set up functional safety features and condition-based monitoring. A microSD card can be used as a storage device for data logging, making backups, and restoring the system from a backup.

The Logic feature in MyDrive® Insight enables the customization and control of drives through a graphical user interface without the need for a separate programming tool. It allows for conditional controls, fault detection and diagnostics, and the creation of sequencing and interlocking logic. Programmable function blocks with inputs and outputs can be connected to control the digital or analog outputs of the drive.

MyDrive® Insight is available for download at <https://suite.mydrive.danfoss.com>.

## 7 Options and Accessories

### 7.1 Overview of Options and Accessories

The iC7 series also includes various options and accessories, including:

- Functional extensions
- Control panels
- Fieldbus communication options
- Filters

When ordered separately, the option shipments include a printed guide with the basic installation and safety instructions.

### 7.2 Fieldbus Options

The drive is fitted with a Modbus TCP protocol as standard.

The following protocols are available as alternative selections from factory, or as field upgrades with a proof-of-purchase token:

- PROFINET RT OS7PR
- EtherNet/IP OS7IP
- EtherCAT OS7EC

For the order codes of fieldbus options, see [12.2.4 Control Board Features \(+Bxxx\)](#).

### 7.3 Functional Extension Options

#### 7.3.1 Overview

More I/O functions can be added to the iC7-Automation frequency converters to match the specific needs of applications. Depending on the frequency converter frame, up to 4 functional extensions can be added.

**Table 5: Functional Extension Options for iC7-Automation Frequency Converters**

Option	Description
General Purpose I/O OC7C0	The General Purpose I/O option adds 3 digital inputs, 2 digital outputs, 2 analog inputs, 1 analog output, and temperature measurement support (Pt1000, Ni1000, and KTY81).
Relay Option OC7R0	The Relay option offers 3 more relays: 2 NO/NC and 1 NO rated for up to 250 V AC/2 A.
Encoder/Resolver Option OC7M0	<p>The Encoder/Resolver option allows the connection of 1 or 2 devices as speed/position feedback or reference. The following devices are supported:</p> <ul style="list-style-type: none"> <li>• Incremental encoder (TTL, HTL, and SinCos)</li> <li>• Absolute encoder (SSI, HIPERFACE®, HIPERFACE DSL®, EnDat, BiSS B/C)</li> <li>• Resolver</li> </ul> <p>In addition, a TTL encoder simulation output can be used to mirror one of the encoder/resolver inputs or other position signals.</p>
Temperature Measurement OC7T0	The Temperature Measurement option adds 5 temperature sensor inputs with compensation input. Supported sensors are Pt100, Pt1000, Ni1000, and KTY81.

#### 7.3.2 Option Slots

The options are placed in option slots A–E. For more information on the detailed physical positions of the option slots, see [Figure 7](#).

As the connections to some option positions are established via other options, the following dependencies must be observed when designing the system:

- Option in slot B requires an option in slot A.
- Option in slot D requires an option in slot C.
- Option in slot E requires options in both slot C and slot D.

**i TIP:** When ordering frames Fx02–Fx05 without options or an option in slot A only, it is important to consider carefully if more than 1 option is needed later. Adding more options increases the depth of the frequency converter. To ensure upgradability, select code +CBX0 when ordering a frequency converter.

**Table 6: Number of Functional Extensions per Frame**

Frame	Number of options	Option slot
FA02a–FA05a	1	A
FA02b	2	A, B
FA03b–FA04b	3	A, B, C
FA05b	4	A, B, C, D
FA06–FA12	4	A, C, D, E
FB09–FB12		
FK06–FK12		



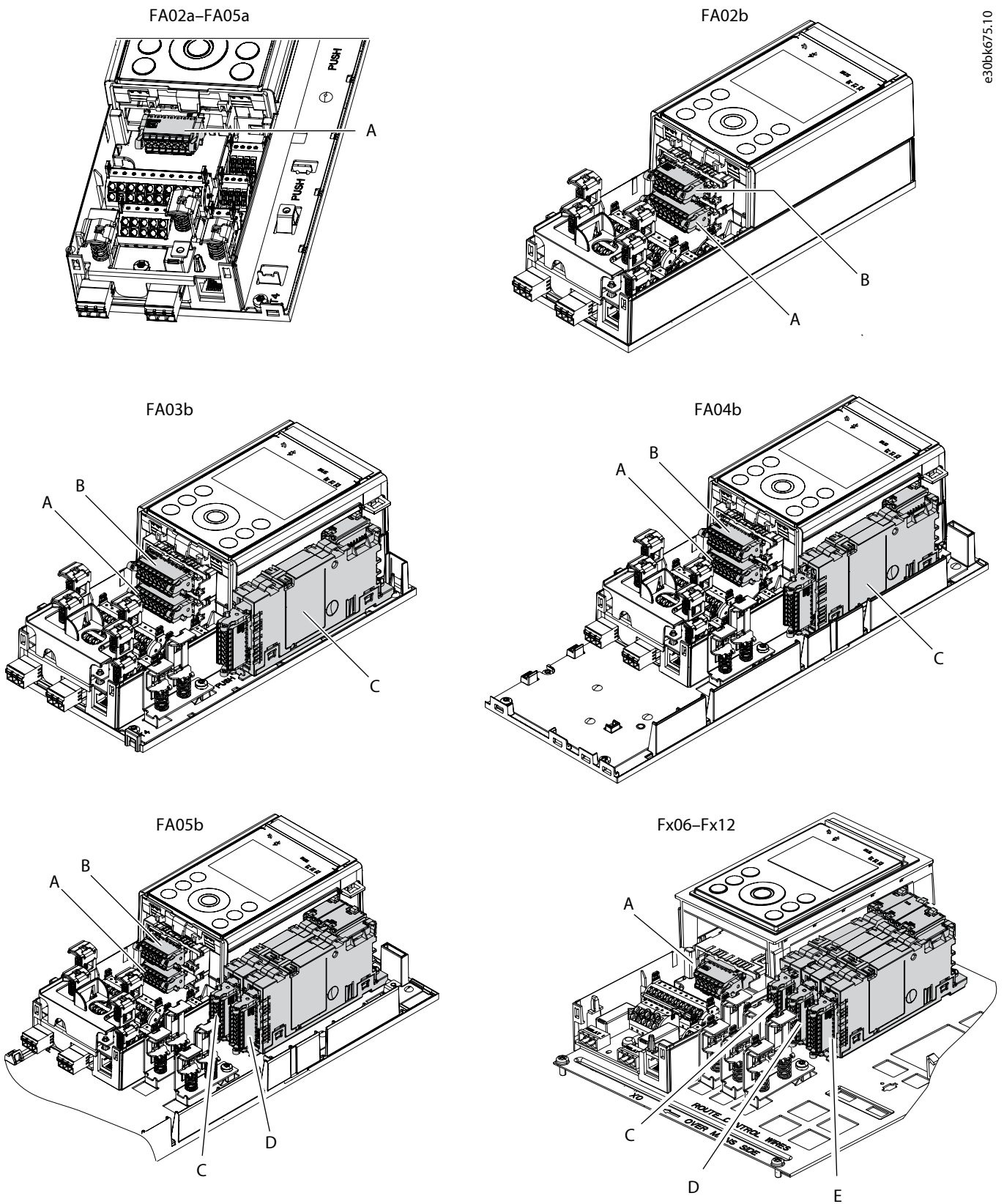

Figure 7: Option Slot Locations in iC7-Automation Frequency Converters

## 7.4 Filters and Braking Options

### 7.4.1 Sine-wave Filters

Sine-wave filters are installed on the output of the frequency converter when additional motor protection is needed, or for reduction of acoustical switching noise from the motor.

The filter provides a sinusoidal output to the motor. The sine-wave filter also reduces motor insulation stress, and is needed when the operating conditions on motor terminals exceed motor specifications. The acoustic noise from the motor is also damped as a consequence of the sinusoidal wave condition.

An IP21/UL Type 1 kit is available to upgrade the protection rating of the IP20/UL Open Type Sine-wave Filter to IP21/UL Type 1. For guidance on selecting and ordering the correct filter and accessories, see [12.3.2.1 Sine-wave Filters Selection Guidelines](#).

### 7.4.2 dU/dt Filters

dU/dt filters are installed on the output of the drive, when additional motor protection is needed to reduce the dU/dt voltage stress on the motor insulation caused by the voltage commutations of the drive.

Compared to sine-wave filters, dU/dt filters have a higher cut-off frequency, and lower inductance and capacitance values. With a dU/dt filter, the voltage waveform supplied to the motor is still pulse-shaped, but the current is sinusoidal.

### 7.4.3 Common-mode Filters

High-frequency common mode (HF-CM) filters are used to reduce common-mode currents, typically to reduce bearing currents or to reduce high-frequency currents that circulate in the system grounding.

HF-CM filters can be used with other mitigation measures, such as dU/dt and sine-wave filters.

For details on ordering common-mode filter kits, see [12.4 Ordering Options and Accessories](#).

### 7.4.4 Harmonic Filters

Harmonic filters reduce the harmonic load on the mains supply. Dedicated filters offer a reduction of the total harmonic distortion (THDi) to 5% or 10%.

The Advanced Harmonic Filter OF7P2 is a passive harmonic filter with an efficient 2-stage tuned absorption circuit. The absorption circuit is specially tuned to eliminate harmonics starting with the 5th harmonic, and is designed specifically for the supply frequency.

The Advanced Harmonic Filter features a compact IP20/UL Open Type enclosure that is easily integrated into existing panel space or next to the drive. The filter is intended to be mounted on a solid surface. If the filter is installed on a pedestal, or mounted on a perforated wall in a cabinet, a back plate is required.

An optional IP21/UL Type 1 kit is also available for improved protection.

For guidance on selecting and ordering the correct filter and accessories, see [12.3.1.1 Harmonic Filters Selection Guidelines](#).

### 7.4.5 Brake Resistors

In applications where the motor is used as a brake, energy is generated in the motor and sent back into the drive. If the energy cannot be transported back to the motor, it increases the voltage in the drive DC line. In applications with frequent braking and/or high inertia loads, this increase can lead to an overvoltage trip in the drive and, finally, a shutdown.

Brake resistors are used to dissipate the excess energy resulting from the regenerative braking. The resistor is selected based on its ohmic value, its power dissipation rate, and its physical size. Danfoss offers a wide variety of different resistors that are specially designed for Danfoss drives.

## 7.4.6 Braking with the Frequency Converter

### 7.4.6.1 Overview of Braking with the Frequency Converter

When braking the motor and its connected load, energy is fed back to the frequency converter. As a result, the DC-link voltage increases. There are 3 potential methods for the frequency converter to dissipate energy and keep the DC voltage within an operational range:

- Applying AC brake to the motor: The frequency converter utilizes the losses in a motor (typical induction motor), and by over-magnetization the excess energy is dissipated in the motor. Applying AC brake to the motor typically works with smaller, less efficient motors, and steps up the braking performance where braking time is not critical, and cyclic braking is not needed.
- Load sharing: In a load sharing scenario, the excess energy is shared with other frequency converters connected via a DC connection. The amount of energy that can be dissipated depends on the total system load and capability to use the excess energy.
- Resistor braking: The excess energy is dissipated into a resistor by a brake chopper in the frequency converter. The resistor must be matched to the application and frequency converter to deliver the required performance.

The duration and power dissipated during the braking sequence depends on the application characteristics, for example, inertia, lowering of the load, and continuous braking.

Cyclic braking (up to 1 min every 5 min or 10 min) is possible within the allowed load characteristics of the drive. If braking for a longer time (>1 min every 5 min or 10 min), the braking power should not exceed the nominal power rating of the drive.

For more information on brake capability limitations, see [8.2.6 Brake Ratings 380–500 V AC](#).

For more information on resistor braking, see [7.4.6.2 Resistor Braking](#).

### 7.4.6.2 Resistor Braking

The excess energy is dissipated in a brake resistor connected to the brake output of the drive.

The brake resistor must be sized to match the amount of energy to be removed from the application, the applied braking power, and the brake voltage of the drive. The following information is needed to size the brake resistor correctly:

- Maximum braking power ( $P_{peak}$ )
- Duration of the braking cycle ( $t_{cycle}$ )
- Actual braking period ( $t_{brake}$ )

### 7.4.6.3 Selecting a Brake Resistor

Select a brake resistor based on the actual drive and needed brake performance. When selecting a resistor matched specifically to a certain application, follow these instructions.

1. Calculate the maximum ohmic value of the brake resistor:  $R_{rec} = \frac{U_{DC}^2 \times 100}{P_{motor} \times M_b(\%) \times \eta_{FC} \times \eta_{motor}}$

$P_{motor}$  must be entered in watts. See [Table 7](#) for the  $U_{DC}$  rating. The brake voltage level depends on the supply voltage and unit voltage class selection. The unit voltage class is set in parameter **2.2.1.1 Unit Voltage Class** (parameter number **2832**).

**Table 7:  $U_{DC}$  Rating for Calculations**

Supply voltage	Mains voltage in model code	Unit voltage class setting	$U_{DC}$ value (V)
380–500 V	05	Low	705
		Medium	770
		High	780

$M_{br(\%)}$  is the torque during braking. When braking above nominal torque (100% torque), the applied load curve (LO, HO1, or HO2) of the drive must be observed.

$\eta_{FC}$  is the efficiency of the drive, and  $\eta_{motor}$  is the efficiency of the motor.

➡ Using  $M_{br\%} = 150\%$ ,  $\eta_{FC} = 0.98$ ,  $\eta_{motor} = 0.96$  for drives rated at 380–500 V (model code 05), the calculation can be simplified to:

- When brake voltage is set to Medium or High for a 380–500 V rated drive:

$$R_{rec} = \frac{420000}{P_{motor}}$$

- When brake voltage is set to Low for 380–500 V rated drive:

$$R_{rec} = \frac{352000}{P_{motor}}$$

2. Check that the resistance of the brake resistor is within acceptable range for the drive. Ensure that the frequency converter matches the braking power. If a resistor with too high an ohmic value is selected, the frequency converter is not able to brake at the needed performance level.

When selecting a brake resistor for a specific application, follow these extra steps:

3. Calculate the maximum power dissipated in the resistor:

$$P_{res} > \frac{U_{DC}^2}{R_{rec}}$$

4. Select a resistor that matches both the maximum power, and can consume the energy dissipated to the resistor (continuous power rating) under the given installation conditions according to the braking load curve based on  $P_{peak}$ ,  $t_{brake}$ , and  $t_{cycle}$  values.

➡ Based on the calculations, select the correct brake resistor to match the requirements of the system and the application.

**What to do next:** For information on setting parameters for brake resistor operation, such as resistance, power value, and thermal monitoring, refer to the application guide.

#### 7.4.6.4 Brake Performance Considerations

The frequency converter must be able to brake at the required power rating. See [Table 8](#) for information on the minimum and maximum resistance of the brake resistor.

If braking continuously with frames Fx02–Fx08, the nominal power of the frequency converter must not be exceeded.

**Table 8: Brake Resistor Ratings for 380–500 V Rated Drives**

Product code <sup>(1)</sup>	$R_{min}$ [ $\Omega$ ]	$R_{max}$ [ $\Omega$ ]
05-01A3	418	4650
05-01A8	418	4650
05-02A4	408	4650
05-03A0	201	2240
05-04A0	198	2240
05-05A6	98	1090

**Table 8: Brake Resistor Ratings for 380–500 V Rated Drives** (continued)

Product code <sup>(1)</sup>	R <sub>min</sub> [Ω]	R <sub>max</sub> [Ω]
05-07A2	98	1090
05-09A2	52	580
05-12A5	52	580
05-16A0	37	420
05-24A0	25	280
05-31A0	18	200
05-38A0	12.6	140
05-43A0	12.6	140
05-61A0	8	89
05-73A0	8	89
05-90A0	5.3	59
05-106A	5.3	59
05-147A	3.2	36
05-170A	3.2	36
05-206A	3.6	36
05-245A	2.9	29
05-302A	2.4	24
05-395A	2	20
05-480A	1.6	16
05-588A	1.4	14
05-658A	1.5	15
05-736A	0.8	8
05-799A	0.9	9
05-893A	2.0	20
05-1000	0.85	8.5
05-1120	0.9	9
05-1260	0.8	8

1) The product code consists of the mains voltage code and current rating code of the model code. For more information, see [12.2.1 Overview](#).

Frames FA02–FA05 have the brake chopper built in as standard. For other frames, the brake chopper is an optional selection indicated in the model code, for example +ACBC.

#### 7.4.6.5 Brake Resistor Installation Considerations

- Use a shielded cable to connect the brake resistor, and keep the cable length as short as possible to minimize electromagnetic emissions. The maximum cable length to the brake resistor is 10 m (33 ft).

- Place the brake resistor in a location where it is possible to cool the resistor. To avoid the risk of fire, pay attention to the environmental conditions and installation location, as the brake resistor gets hot during operation. Avoid flammable material close to the brake resistor.
- To ensure thermal protection of the brake resistor in overload conditions, brake resistors with a built-in thermal switch can be monitored by the frequency converter. For details, refer to the application guide.
- When installing the brake resistor, follow local regulations and the guidelines of the respective resistor.

## 7.5 Kits and Accessories

### 7.5.1 Overview of Kits and Accessories

An extensive selection of kits, accessories, and service parts are available to support installation, flexible layout, upgradability, and continuous operation of the iC7-Automation frequency converters.

### 7.5.2 Back-channel Cooling Kits

Back-channel cooling applies to frames Fx09–Fx12, and is an alternative to the traditional way of dissipating heat internally in an electrical installation cabinet or electrical room, where heat is removed by extra fans or cooling units.

In back-channel cooling, a unique back-channel duct passes cooling air over the heat sinks with minimal air passing through the electronics area. There is an IP54/UL Type 12 seal between the back-channel cooling duct and the electronics area of the iC7-Automation frequency converter. Back-channel cooling allows 90% of the heat losses to be exhausted directly outside the enclosure and makes it possible to reduce the size of the cooling system in the panel or switch room considerably. This design improves reliability and prolongs component life by dramatically reducing internal cabinet temperatures and contamination of the electronic components.

Different back-channel cooling kits are available to redirect the airflow based on individual needs. For more information, see [10.8.8.3 Back-channel Cooling](#). For information on ordering cooling kits, see [12.4 Ordering Options and Accessories](#).

### 7.5.3 Pedestal Kits

Two variants of optional pedestal kits are available for the free-standing FK09–FK12 frequency converters:

- 200 mm (7.9 in)
- 400 mm (15.8 in)

A pedestal and a cable entry plate are required for proper operation of the drive. The pedestal features a front grill to allow proper airflow for cooling the drive.

Frames FK10c/FB10c, FK11/FB11, and FK12/FB12 are delivered with a 200 mm (7.9 in) pedestal as a standard offering, since these frequency converters are always mounted as free-standing.

Available pedestal kits are listed in [12.4 Ordering Options and Accessories](#). For details on the installation, refer to the installation guides of the kits.

### 7.5.4 Control Panel Mounting Kits and Cables

Control panels can also be mounted apart from the drives, for example on a wall or panel, allowing remote control and monitoring of the drives. The protection rating of the mounting kits is IP55/UL Type 21.

The control panel requires a dedicated cable. The maximum supported length of the control panel cable is 10 m (33 ft).

There are 2 types of mounting kits:

- Flush mounting kit
- Surface mounting kit

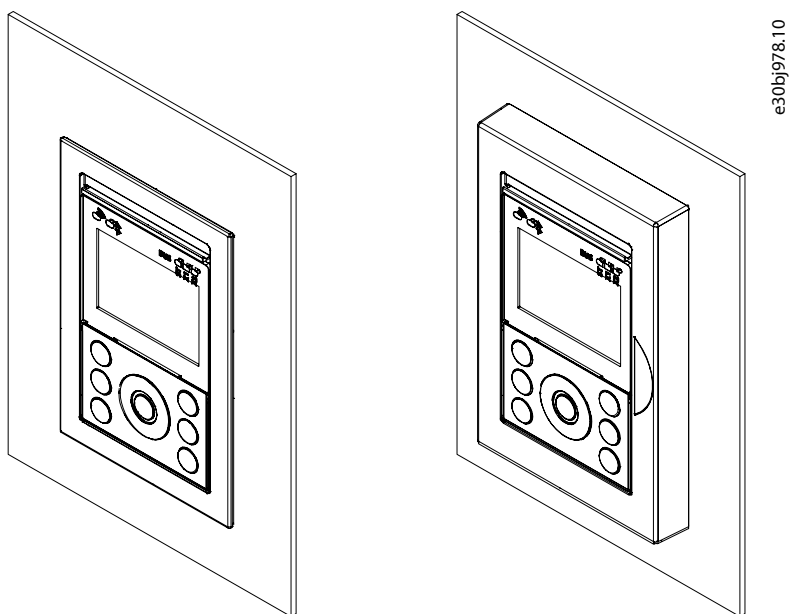

Figure 8: Control Panel Mounted in Flush Mounting Kit (Left) and Surface Mounting Kit (Right)

The available mounting kits and cable options are listed in [12.4 Ordering Options and Accessories](#). For detailed information about installing mounting kits, refer to *iC7 Series Control Panel Mounting Kits Installation Guide*.

### 7.5.5 Cable and Wire Installation Kits

Additional cable and wire installation kits are available to facilitate wiring and to provide extra grounding points.

The multi-wire kit enables the connection of 3 wires to a single terminal in frames Fx09–Fx10. The kit includes parts for making multi-wire connections to 3 mains terminals and 3 motor terminals. The ground bar kit provides extra grounding points for FK09–FK12/FB09–FB12 frames.

For details on ordering multi-wire and ground bar kits, see [12.4 Ordering Options and Accessories](#).

## 8 Specifications

### 8.1 Overview

This chapter covers the general technical data that is required to select a frequency converter for a specific application.

### 8.2 Ratings

#### 8.2.1 Overview

The rating tables provide maximum ratings of the frequency converters at three overload ratings. Pay attention to the supply voltage range when selecting the correct frequency converter. The overload ratings are:

- Low Overload (LO): Overload capability of 110% for 1 min every 10 mins. Typically used where limited or no overload current is needed.
- High Overload (HO1): Overload capability of up to 160% for 1 min every 10 mins. This mode supports increased current for a shorter time, for example acceleration of heavier loads and cyclic operations with long cycle times.
- High Overload with increased duty (HO2): Overload capability of up to 160% for 1 min every 5 mins. This mode supports operations with increased cyclic operations.

For more information on the overload modes, see [5.6.1 Load Profile Overview](#).

Typical motor power ratings are given in kW and HP at defined voltage levels for 4-pole IEC2-rated induction motors.

If operated outside nominal conditions, derating is required. For detailed information on derating, see [10.6.1 Overview of Derating for Operating Conditions](#).

The rating tables refer to frequency converters by a product code that consists of the mains voltage code and current rating code as defined in the model code positions 11–17, for example "05-12A5". For more information about the model code, see [12.2.1 Overview](#).

The input current ratings ( $I_{L-in}$ ,  $I_{HO1-in}$  and  $I_{HO2-in}$ ) are RMS values. The fundamental input current rating is typically 10% lower.

**Table 9: Abbreviations Used in the Rating Tables**

Abbreviation	Long form	Description
$I_{[X]-in}^{(1)}$	Input current	Rated continuous input current at the selected overload capability
$I_{[X]}^{(1)}$	Rated output current	Rated continuous output current of the selected overload capability
$I_{[X]-OL}^{(1)}$	Overload current	Overload current (1 min) available for the selected overload capability
$P_{typ}$	Typical power	Typical motor power

1) In the ratings tables, [X] is replaced with the relevant overload type abbreviation:

- L: Low Overload
- HO1: High Overload
- HO2: High Overload - Increased duty

#### 8.2.2 Ratings for Frequency Converters with 380–500 V Supply Voltage

The ratings for the frequency converters rated for 380–500 V AC supply are given at 3 different voltage ratings:

- kW at 400 V
- HP at 460 V



- kW at 500 V

### NOTICE

- When selecting the frequency converter, pay attention to both the supply voltage and the overload rating.
- Voltage range is selected in parameter **2.2.1.1 Unit Voltage Class**, and should be selected according to supply voltage.

Table 10: Operational Voltage Ranges

Supply voltage	Mains voltage in model code	Unit voltage class setting	Voltage range
380–500 V	05	Low	380–440 V
		Medium	441–480 V
		High	481–500 V

## 8.2.3 Current and Power Ratings 380–440 V AC

 Table 11: Current and Power Rating 380–440 V AC – Voltage Class: Low ( $P_{typ}$  in kW at 400 V)

Product code <sup>(1)</sup>	Low overload				High overload				High overload, increased duty				Frame
	$I_{L-in}$ [A]	$I_L$ [A]	$I_{L-OL}$ [A]	$P_{typ}$ [kW]	$I_{HO1-in}$ [A]	$I_{HO1}$ [A]	$I_{HO1-OL}$ [A]	$P_{typ}$ [kW]	$I_{HO2-in}$ [A]	$I_{HO2}$ [A]	$I_{HO2-OL}$ [A]	$P_{typ}$ [kW]	
05-01A3	1.1	1.3	1.4	0.37	1.1	1.3	2.1	0.37	0.8	0.9	1.4	0.25	Fx02
05-01A8	1.5	1.8	2.0	0.55	1.5	1.8	2.9	0.55	1.0	1.3	2.1	0.37	Fx02
05-02A4	2.0	2.4	2.6	0.75	2.0	2.4	3.8	0.75	1.5	1.8	2.9	0.55	Fx02
05-03A0	2.6	3.0	3.3	1.1	2.6	3.0	4.8	1.1	2.0	2.4	3.8	0.75	Fx02
05-04A0	3.5	4.0	4.4	1.5	3.5	4.0	6.4	1.5	2.6	3.4	5.4	1.1	Fx02
05-05A6	5.0	5.6	6.2	2.2	5.0	5.6	9.0	2.2	3.5	4.3	6.9	1.5	Fx02
05-07A2	6.5	7.2	7.9	3.0	6.5	7.2	11.5	3.0	5.0	5.6	9.0	2.2	Fx02
05-09A2	8.5	9.2	10.1	4.0	8.5	9.2	14.7	4.0	6.5	8.0	12.8	3.0	Fx02
05-12A5	11.2	12.5	13.8	5.5	11.2	12.5	20.0	5.5	8.5	10.0	16.0	4.0	Fx02
05-16A0	15.3	16.0	17.6	7.5	15.3	16.0	25.6	7.5	11.2	13.0	20.8	5.5	Fx03
05-24A0	22	24	26	11	22	24	38	11	15.0	17.0	27	7.5	Fx04
05-31A0	30	31	34	15	30	31	50	15	22	25	40	11	Fx04
05-38A0	36	38	42	18.5	36	38	57	18.5	30	32	51.2	15	Fx05
05-43A0	43	43	47	22	43	43	65	22	36	38	60.8	18.5	Fx05
05-61A0	57	61	67	30	57	61	92	30	43	46	69	22	Fx06
05-73A0	70	73	80	37	70	73	110	37	57	61	92	30	Fx06
05-90A0	85	90	99	45	85	90	135	45	70	73	110	37	Fx07
05-106A	103	106	117	55	103	106	159	55	85	90	135	45	Fx07

**Table 11: Current and Power Rating 380–440 V AC – Voltage Class: Low ( $P_{typ}$  in kW at 400 V) (continued)**

Product code <sup>(1)</sup>	Low overload				High overload				High overload, increased duty				Frame
	$I_{L-in}$ [A]	$I_L$ [A]	$I_{L-OL}$ [A]	$P_{typ}$ [kW]	$I_{HO1-in}$ [A]	$I_{HO1}$ [A]	$I_{HO1-OL}$ [A]	$P_{typ}$ [kW]	$I_{HO2-in}$ [A]	$I_{HO2}$ [A]	$I_{HO2-OL}$ [A]	$P_{typ}$ [kW]	
05-147A	139	147	162	75	139	147	221	75	103	106	159	55	Fx08
05-170A	167	170	187	90	167	170	255	90	139	147	221	75	Fx08
05-206A	198	206	227	110	164	170	255	90	142	147	221	75	Fx09
05-245A	236	245	270	132	198	206	309	110	164	170	255	90	Fx09
05-302A	291	302	332	160	236	245	368	132	198	206	309	110	Fx09
05-385A	371	385	424	200	291	302	453	160	236	245	368	132	Fx09
05-395A	380	395	435	200	291	302	453	160	236	245	368	132	Fx10
05-480A	462	480	528	250	371	385	578	200	291	302	453	160	Fx10
05-588A	566	588	647	315	462	480	720	250	371	385	578	200	Fx10
05-658A	633	658	724	355	566	588	882	315	462	480	720	250	Fx11
05-736A	709	736	810	400	633	658	987	355	566	588	882	315	Fx11
05-799A	769	799	879	450	669	695	1043	400	633	658	987	355	Fx11
05-893A	860	893	982	500	769	799	1199	450	709	736	1104	400	Fx12
05-1000	963	1000	1100	560	847	880	1320	500	769	799	1199	450	Fx12
05-1120	1078	1120	1232	630	963	1000	1500	560	860	893	1340	500	Fx12
05-1260	1200	1260	1386	710	1059	1100	1650	630	963	1000	1500	560	Fx12

1) The product code consists of the mains voltage code and current rating code of the model code. For more information, see [12.2.1 Overview](#).

## 8.2.4 Current and Power Ratings 441–480 V AC

**Table 12: Current and Power Rating 441–480 V AC – Voltage Class: Medium ( $P_{typ}$  in HP at 460 V)**

Product code <sup>(1)</sup>	Low overload				High overload				High overload, increased duty				Frame
	$I_{L-in}$ [A]	$I_L$ [A]	$I_{L-OL}$ [A]	$P_{typ}$ [HP]	$I_{HO1-in}$ [A]	$I_{HO1}$ [A]	$I_{HO1-OL}$ [A]	$P_{typ}$ [HP]	$I_{HO2-in}$ [A]	$I_{HO2}$ [A]	$I_{HO2-OL}$ [A]	$P_{typ}$ [HP]	
05-01A3	0.9	1.2	1.3	0.5	0.9	1.2	1.9	0.5	0.7	0.8	1.3	0.33	Fx02
05-01A8	1.3	1.6	1.8	0.75	1.3	1.6	2.6	0.75	0.9	1.1	1.8	0.5	Fx02
05-02A4	1.8	2.1	2.3	1	1.8	2.1	3.4	1	1.3	1.6	2.6	0.75	Fx02
05-03A0	2.3	2.7	3.0	1.5	2.3	2.7	4.3	1.5	1.8	2.1	3.4	1	Fx02
05-04A0	3.1	3.4	3.7	2	3.1	3.4	5.4	2	2.3	3.0	4.8	1.5	Fx02
05-05A6	4.3	4.8	5.3	3	4.3	4.8	7.7	3	3.1	3.4	5.4	2	Fx02
05-07A2	5.7	6.3	6.9	4	5.7	6.3	10.1	4	4.3	4.8	7.7	3	Fx02

Table 12: Current and Power Rating 441–480 V AC – Voltage Class: Medium ( $P_{typ}$  in HP at 460 V) (continued)

Product code <sup>(1)</sup>	Low overload				High overload				High overload, increased duty				Frame
	$I_{L-in}$ [A]	$I_L$ [A]	$I_{L-OL}$ [A]	$P_{typ}$ [HP]	$I_{HO1-in}$ [A]	$I_{HO1}$ [A]	$I_{HO1-OL}$ [A]	$P_{typ}$ [HP]	$I_{HO2-in}$ [A]	$I_{HO2}$ [A]	$I_{HO2-OL}$ [A]	$P_{typ}$ [HP]	
05-09A2	7.4	8.2	9.0	5	7.4	8.2	13.1	5	5.7	6.3	10.1	4	Fx02
05-12A5	9.8	11.0	12.1	7.5	9.8	11.0	17.6	7.5	7.4	7.6	12.2	5	Fx02
05-16A0	13.4	14.5	16.0	10	13.4	14.5	23.2	10	9.8	11.0	17.6	7.5	Fx03
05-24A0	20	21	23	15	20	21	34	15	13.0	14.5	23	10	Fx04
05-31A0	26	27	30	20	26	27	43	20	20	21	34	15	Fx04
05-38A0	31	34	37	25	31	34	51	25	26	27	41	20	Fx05
05-43A0	37	40	44	30	37	40	60	30	31	34	51	25	Fx05
05-61A0	50	55	61	40	50	55	83	40	37	40	60	30	Fx06
05-73A0	61	66	73	50	61	66	99	50	50	55	83	40	Fx06
05-90A0	74	81	89	60	74	81	122	60	61	66	99	50	Fx07
05-106A	90	96	106	75	90	96	144	75	74	81	122	60	Fx07
05-147A	122	133	146	100	122	133	200	100	90	96	144	75	Fx08
05-170A	145	156	172	125	145	156	234	125	122	133	200	100	Fx08
05-206A	189	196	216	150	160	166	249	125	150	156	234	125	Fx09
05-245A	231	240	264	200	189	196	294	150	160	166	249	125	Fx09
05-302A	291	302	332	250	231	240	360	200	189	196	294	150	Fx09
05-385A	350	364	400	300	291	302	453	250	231	240	360	200	Fx09
05-395A	350	364	400	300	291	302	453	250	231	240	360	200	Fx10
05-480A	439	456	502	350	350	364	546	300	291	302	453	250	Fx10
05-588A	501	520	572	450	439	456	684	350	350	364	546	300	Fx10
05-658A	568	590	649	500	501	520	780	450	439	456	684	350	Fx11
05-736A	633	658	724	550	568	590	885	500	501	520	780	450	Fx11
05-799A	703	730	803	600	629	653	980	550	568	590	885	500	Fx11
05-893A	755	784	862	650	674	700	1050	550	629	653	980	550	Fx12
05-1000	863	896	986	750	755	784	1176	650	674	700	1050	550	Fx12
05-1120	990	1028	1131	850	863	896	1344	750	755	784	1176	650	Fx12
05-1260	1107	1150	1265	950	990	1028	1542	850	863	896	1344	750	Fx12

 1) The product code consists of the mains voltage code and current rating code of the model code. For more information, see [12.2.1 Overview](#).

## 8.2.5 Current and Power Ratings 481–500 V AC

**Table 13: Current and Power Rating 481–500 V AC – Voltage Class: High ( $P_{typ}$  in kW at 500 V)**

Product code <sup>(1)</sup>	Low overload				High overload				High overload, increased duty				Frame
	$I_{L-in}$ [A]	$I_L$ [A]	$I_{L-OL}$ [A]	$P_{typ}$ [kW]	$I_{HO1-in}$ [A]	$I_{HO1}$ [A]	$I_{HO1-OL}$ [A]	$P_{typ}$ [kW]	$I_{HO2-in}$ [A]	$I_{HO2}$ [A]	$I_{HO2-OL}$ [A]	$P_{typ}$ [kW]	
05-01A3	0.9	1.2	1.3	0.37	0.9	1.2	1.9	0.37	0.5	0.8	1.3	0.25	Fx02
05-01A8	1.2	1.6	1.8	0.55	1.2	1.6	2.6	0.55	0.8	1.1	1.8	0.37	Fx02
05-02A4	1.6	2.1	2.3	0.75	1.6	2.1	3.4	0.75	1.2	1.6	2.6	0.55	Fx02
05-03A0	2.1	2.7	3.0	1.1	2.1	2.7	4.3	1.1	1.4	2.1	3.4	0.75	Fx02
05-04A0	2.8	3.4	3.7	1.5	2.8	3.4	5.4	1.5	2.1	3.0	4.8	1.1	Fx02
05-05A6	4.0	4.8	5.3	2.2	4.0	4.8	7.7	2.2	2.8	3.4	5.4	1.5	Fx02
05-07A2	5.2	6.3	6.9	3.0	5.2	6.3	10.1	3.0	4.0	4.8	7.7	2.2	Fx02
05-09A2	6.8	8.2	9.0	4.0	6.8	8.2	13.1	4.0	5.2	6.3	10.1	3.0	Fx02
05-12A5	9.0	11.0	12.1	5.5	9.0	11.0	17.6	5.5	6.8	7.6	12.2	4.0	Fx02
05-16A0	12.3	14.5	16.0	7.5	12.3	14.5	23.2	7.5	9.0	11.0	17.6	5.5	Fx03
05-24A0	18.0	21	23	11	18.0	21	34	11	12.0	14.5	23	7.5	Fx04
05-31A0	24	27	30	15	24	27	43	15	18.0	21	34	11	Fx04
05-38A0	29	34	37	18.5	29	34	51	18.5	24	27	41	15	Fx05
05-43A0	34	40	44	22	34	40	60	22	29	34	51	18.5	Fx05
05-61A0	46	55	61	30	46	55	83	30	34	40	60	22	Fx06
05-73A0	56	66	73	37	46	66	99	37	46	55	83	30	Fx06
05-90A0	68	81	89	45	68	81	122	45	56	66	99	37	Fx07
05-106A	82	96	106	55	82	96	144	55	68	81	122	45	Fx07
05-147A	111	133	146	75	111	133	200	75	90	96	144	55	Fx08
05-170A	133	156	172	90	133	156	234	90	82	133	200	75	Fx08
05-206A	189	196	216	132	160	166	249	110	150	156	234	90	Fx09
05-245A	231	240	264	160	189	196	294	132	160	166	249	110	Fx09
05-302A	291	302	332	200	231	240	360	160	189	196	294	132	Fx09
05-385A	350	364	400	250	291	302	453	200	231	240	360	160	Fx09
05-395A	350	364	400	250	291	302	453	200	231	240	360	160	Fx10
05-480A	439	456	502	315	350	364	546	250	291	302	453	200	Fx10
05-588A	501	520	572	355	439	456	684	315	350	364	546	250	Fx10
05-658A	568	590	649	400	501	520	780	355	439	456	684	315	Fx11
05-736A	633	658	724	450	568	590	885	400	501	520	780	355	Fx11

**Table 13: Current and Power Rating 481–500 V AC – Voltage Class: High (P<sub>typ</sub> in kW at 500 V) (continued)**

Product code <sup>(1)</sup>	Low overload				High overload				High overload, increased duty				Frame
	I <sub>L-in</sub> [A]	I <sub>L</sub> [A]	I <sub>L-OL</sub> [A]	P <sub>typ</sub> [kW]	I <sub>HO1-in</sub> [A]	I <sub>HO1</sub> [A]	I <sub>HO1-OL</sub> [A]	P <sub>typ</sub> [kW]	I <sub>HO2-in</sub> [A]	I <sub>HO2</sub> [A]	I <sub>HO2-OL</sub> [A]	P <sub>typ</sub> [kW]	
05-799A	703	730	803	500	629	653	980	450	568	590	885	400	Fx11
05-893A	755	784	862	560	674	700	1050	500	629	653	980	450	Fx12
05-1000	863	896	986	630	755	784	1176	560	674	700	1050	500	Fx12
05-1120	990	1028	1131	710	863	896	1344	630	755	784	1176	560	Fx12
05-1260	1107	1150	1265	800	990	1028	1542	710	863	896	1344	630	Fx12

1) The product code consists of the mains voltage code and current rating code of the model code. For more information, see [12.2.1 Overview](#).

## 8.2.6 Brake Ratings 380–500 V AC

The brake ratings specified in [Table 14](#) refer to the braking capabilities of the drive.

**Table 14: Brake Ratings at 380–500 V AC**

Product code <sup>(1)</sup>	Low Overload <sup>(2)</sup>			High overload			High overload, increased duty			Frame
	P <sub>typ</sub> [kW]	Continuous braking	Cyclic braking	P <sub>typ</sub> [kW]	Continuous braking	Cyclic braking	P <sub>typ</sub> [kW]	Continuous braking	Cyclic braking	
05-01A3	0.37	100%	110%	0.37	100%	160%	0.25	100%	160%	Fx02
05-01A8	0.55	100%	110%	0.55	100%	160%	0.37	100%	160%	Fx02
05-02A4	0.75	100%	110%	0.75	100%	160%	0.55	100%	160%	Fx02
05-03A0	1.1	100%	110%	1.1	100%	160%	0.75	100%	160%	Fx02
05-04A0	1.5	100%	110%	1.5	100%	160%	1.1	100%	160%	Fx02
05-05A6	2.2	100%	110%	2.2	100%	160%	1.5	100%	160%	Fx02
05-07A2	3	100%	110%	3	100%	160%	2.2	100%	160%	Fx02
05-09A2	4	100%	110%	4	100%	160%	3	100%	160%	Fx02
05-12A5	5.5	100%	110%	5.5	100%	160%	4	100%	160%	Fx02
05-16A0	7.5	100%	110%	7.5	100%	160%	5.5	100%	160%	Fx03
05-24A0	11	100%	110%	11	100%	160%	7.5	100%	160%	Fx04
05-31A0	15	100%	110%	15	100%	160%	11	100%	160%	Fx04
05-38A0	18.5	100%	110%	18.5	100%	150%	15	100%	150%	Fx05
05-43A0	22	100%	110%	22	100%	150%	18.5	100%	150%	Fx05
05-61A0	30	100%	110%	30	100%	150%	22	100%	150%	Fx06
05-73A0	37	100%	110%	37	100%	150%	30	100%	150%	Fx06
05-90A0	45	100%	110%	45	100%	150%	37	100%	150%	Fx07

Table 14: Brake Ratings at 380–500 V AC (continued)

Product code <sup>(1)</sup>	Low Overload <sup>(2)</sup>			High overload			High overload, increased duty			Frame
	P <sub>typ</sub> [kW]	Continuous braking	Cyclic braking	P <sub>typ</sub> [kW]	Continuous braking	Cyclic braking	P <sub>typ</sub> [kW]	Continuous braking	Cyclic braking	
05-106A	55	100%	110%	55	100%	150%	45	100%	150%	Fx07
05-147A	75	100%	110%	75	100%	150%	55	100%	150%	Fx08
05-170A	90	100%	110%	90	100%	150%	75	100%	150%	Fx08
05-206A	110	100%	110%	90	91%	145%	75	91%	145%	Fx09 <sup>(3)</sup>
05-245A	132	100%	110%	110	91%	145%	90	91%	145%	Fx09 <sup>(3)</sup>
05-302A	160	96%	110%	132	100%	150%	110	100%	150%	Fx09 <sup>(3)</sup>
05-385A	–	–	–	–	–	–	–	–	–	Fx09 <sup>(3)</sup>
05-395A	200	100%	110%	160	100%	150%	132	100%	150%	Fx10 <sup>(3)</sup>
05-480A	250	100%	110%	200	100%	150%	160	100%	150%	Fx10 <sup>(3)</sup>
05-588A	315	79%	95%	250	96%	126%	200	96%	126%	Fx10 <sup>(3)</sup>
05-658A	355	94%	110%	315	100%	137%	250	100%	137%	Fx11 <sup>(3)</sup>
05-736A	400	94%	110%	355	100%	113%	315	100%	113%	Fx11 <sup>(3)</sup>
05-799A	450	72%	83%	400	76%	94%	355	76%	94%	Fx11 <sup>(3)</sup>
05-893A	500	48%	48%	450	56%	56%	400	56%	56%	Fx12 <sup>(3)</sup>
05-1000	560	85%	85%	500	93%	93%	450	93%	93%	Fx12 <sup>(3)</sup>
05-1120	630	61%	61%	560	66%	66%	500	66%	66%	Fx12 <sup>(3)</sup>
05-1260	710	61%	61%	630	66%	66%	560	66%	66%	Fx12 <sup>(3)</sup>

1) The product code consists of the mains voltage code and current rating code of the model code. For more information, see [12.2.1 Overview](#).

2) For Fx09–Fx12 frames, see [8.3.8.4 Ambient Conditions during Operation](#) for ambient temperature in low overload mode.

3) For cyclic braking, the braking time is 30 s for Fx09, Fx11, and Fx12, and 20 s for Fx10.

## 8.3 General Technical Data

### 8.3.1 Grid Side

Table 15: Mains Supply

Function	Data
Supply voltage (3-phase)	380–500 V AC $\pm$ 10%, -15% at reduced torque performance, depending on motor type.
Grid types	TN, TT, IT (grounded and ungrounded grids) For details on the parameters related to grid types, refer to the application guide.
Supply frequency	45–65 Hz
Maximum temporary imbalance between mains phases	3% of rated voltage, depending on grid impedance.

**Table 15: Mains Supply** (continued)

Function	Data
True power factor ( $\lambda$ )	$\geq 0.9$ nominal at rated load and 400 V AC supply
Displacement power factor	Near unity ( $>0.98$ )
Switching on input supply from a discharged drive	Fx02-Fx05: Maximum 2 times/min
	Fx06-Fx08: Maximum 1 time/min
	Fx09-Fx12: Maximum 1 time every 2 min
Environment	Overvoltage category III/pollution degree 2

### 8.3.2 Motor Output and Motor Data

**Table 16: Motor Output (U, V, W)**

Function	Data
Output voltage	0–100% of supply voltage
Output frequency	0–590 Hz <sup>(1)</sup>
Frequency resolution	0.001 Hz
Switching on output	Unlimited

1) Dependent on voltage, current, and control mode.

### 8.3.3 Torque Characteristics

**Table 17: Torque Characteristics**

Function		Data
Low overload	Overload torque	110% up to 60 s every 10 min
	Peak torque – Break-away torque	140% for 3 s
High overload (at HO1 rating)	Overload torque	160% for 60 s every 10 min (Fx02–Fx04) <sup>(1)</sup>
		150% for 60 s every 10 min (Fx05–Fx08) <sup>(1)</sup>
		150% for 60 s every 10 min (Fx09–Fx12)
	Peak torque – Break-away torque	175–200% for 3 s (Fx02–Fx05)
		170% for 3 s (Fx06–Fx08)
		170% for 3 s (Fx09–Fx12)
Torque rise time	FVC+ (Flux Vector Control)	1 ms
	VVC+ (Voltage Vector Control)	10 ms

1) Within the thermal limit

### 8.3.4 Control Characteristics

All control characteristics are based on a 4-pole asynchronous motor under the following conditions:

- The drive has been set up with motor nameplate data.
- Automatic Motor Adaptation has been conducted.
- Motor control mode has been set to FVC+.

**Table 18: Control Characteristics**

Function	Data	
	No speed feedback	With speed feedback
Minimum speed with nominal torque	15 rpm	0 rpm
Maximum speed with nominal power	4000 rpm	4000 rpm
Average speed accuracy	±5 rpm	±0.2 rpm
Average torque accuracy	±4%	±4%

### 8.3.5 Control I/O

#### 8.3.5.1 Overview

This chapter covers the general specifications of the control I/O. The actual number of control I/Os depends on the configuration of the control section.

The standard configuration for frequency converters is:

- 24 V external backup
- Dual channel safe input, with galvanic isolation
- STO feedback signal

With Basic I/O (+BDDBA) installed, the following additional I/Os are supported:

- 4 digital inputs
- 2 digital I/O (selected by user)
- 2 analog inputs (voltage or current)
- 1 analog output (current)
- 2 relay outputs (NC/NO)
- 24 V and 10 V reference for digital and analog I/O

All control inputs and outputs are PELV galvanic isolated from supply voltage and other high voltage terminals, unless otherwise specified.

#### 8.3.5.2 Analog Input

Control inputs and outputs are PELV galvanically isolated from supply voltage and other high voltage terminals, unless otherwise specified.



Table 19: Analog Input

Function	Data
Input modes	Current or Voltage <sup>(1)</sup>
Voltage mode	Voltage range: -10 V to 10 V (scalable) Input impedance: 10 kΩ Maximum voltage: +12 V/-12 V
Current mode	<ul style="list-style-type: none"> <li>• Current range: 0/4-20 mA (scalable)</li> <li>• Input impedance: 200 Ω</li> <li>• Maximum current: 24 mA</li> </ul>
Resolution	0.1% of full scale
Accuracy	1% of full scale
Bandwidth	440 Hz
Reaction time	
Temperature sensor support <sup>(2)</sup>	Pt1000, Ni1000, KTY81, KTY82, KTY84, PTC

1) The selection is made in the software. For more information, refer to the application guide.

2) External insulation of the sensor is required to comply with PELV.

### 8.3.5.3 Analog Output

Control inputs and outputs are PELV galvanically isolated from supply voltage and other high voltage terminals, unless otherwise specified.

Table 20: Analog Output

Function	Data
Output range: Current	0/4-20 mA
Minimum load resistor to GND	500 Ω
Resolution	0.1% of full scale
Accuracy	1% of full scale
Bandwidth	440 Hz
Reaction time	< 1 ms

### 8.3.5.4 Digital and Encoder/Pulse Input

Control inputs and outputs are PELV galvanically isolated from supply voltage and other high voltage terminals, unless otherwise specified.

Table 21: Digital and Encoder/Pulse Input

Function		Data
Digital input	Logic	Selectable PNP or NPN
	Voltage levels	0/24 V
	PNP	<ul style="list-style-type: none"> <li>"0": &lt;5 V DC</li> <li>"1": &gt;11 V DC</li> </ul>
	NPN	<ul style="list-style-type: none"> <li>"0": &gt;19 V DC</li> <li>"1": &lt; 13 V DC</li> </ul>
	Maximum allowed voltage	30 V DC
	Input resistance	4.8 k $\Omega$
Thermistor input	PTC <sup>(1)</sup>	1.5–4 k $\Omega$
Pulse/encoder input	Pulse frequency range	0–110 kHz
	Minimum duty cycle	40%
	Accuracy	<ul style="list-style-type: none"> <li>Position resolution: 24 bit</li> <li>Speed resolution: 24 bit</li> </ul>

1) External insulation of the sensor is required to comply with PELV.

### 8.3.5.5 Digital and Pulse Output

Control inputs and outputs are PELV galvanically isolated from supply voltage and other high voltage terminals, unless otherwise specified.

Table 22: Digital and Pulse Output (24 V)

Function	Data
Voltage level	0/24 V
Maximum output load (sink/source)	50 mA
Frequency range - Pulse output	1–100 kHz
Maximum load	1 k $\Omega$
Maximum capacitive load at maximum frequency	10 nF
Pulse output accuracy	0.1% of full scale
Resolution of pulse output	>12 bit

### 8.3.5.6 Relay Output

Relays provide PELV isolation to supply voltage, other high voltage terminals and low voltage control.

Table 23: Relay Output

Function	Data
Relay configuration	SPDT (NO/NC)
Maximum terminal load (AC-1): Resistive load	250 V AC, 2 A
Maximum terminal load (AC-15): Inductive load @ $\cos\phi=0.4$	250 V AC, 0.2 A
Maximum terminal load (DC-1): Resistive load	80 V DC, 2 A
Maximum terminal load (DC-13): Inductive load	24 V DC, 0.1 A
Minimum load	24 V DC, 10 mA 24 V AC, 20 mA
Rated number of cycles (@2 A resistive load)	400.000 switchings

### 8.3.5.7 Auxiliary Voltages

Drives can have multiple power sources, which must be considered when operating the drive. For information on the necessary safety precautions, refer to the product-specific installation, safety, and operating guides.

Auxiliary voltage outputs are used as reference for analog and digital inputs. If mains supply is disconnected, the auxiliary 24 V input is also used as backup source for the control and fieldbus connections. All voltage outputs must be Class 2.

Table 24: Auxiliary Voltages

Function		Data
24 V external supply (X61)	Input voltage	24 V $\pm$ 10%
	Maximum input current	2 A
24 V output, functional safety (X31, X32)	Output voltage	24 V $\pm$ 15%
	Maximum load	100 mA
10 V output - Basic I/O (+BDDBA)	Output voltage	10 V + 2%
	Maximum load	10 mA
24 V output - Basic I/O (+BDDBA)	Output voltage	24 V $\pm$ 20%
	Maximum load	150 mA

### 8.3.6 Functional Safety

#### 8.3.6.1 Functional Safety Standards and Performance

All safety functions in the iC7-Automation frequency converters meet the requirements of the standards listed in this chapter. For details on the functional safety features of iC7-Automation frequency converters, refer to *iC7-Automation Frequency Converters Functional Safety Operating Guide*.

Table 25: Functional Safety Standards

Directive or Standard		Version
European Union directives	Machinery Directive (2006/42/EC)	EN ISO 13849-1:2015, EN ISO 13849-2:2012
		EN IEC 61800-5-2:2007
	EMC Directive (2014/30/EU)	EN IEC 61800-3:2018 – second environment
		EN IEC 61326-3-1:2017
Low Voltage Directive (2014/35/EU)	EN IEC 61800-5-1:2017	
Safety standards	Safety of Machinery	EN ISO 13849-1:2015, IEC 60204-1:2018
	Functional Safety	IEC 61508-1:2010, IEC 61508-2:2010, EN IEC 61800-5-2:2017
Safety function	<b>STO, not upgradable (+BEF1)</b> <ul style="list-style-type: none"> <li>EN IEC 61800-5-2:2017 Safe Torque Off (STO)</li> <li>IEC 60204-1:2018 Stop Category 0</li> </ul>	
	<b>STO, SS1-t, fieldbus (+BEF2)</b> <ul style="list-style-type: none"> <li>EN IEC 61800-5-2:2017 Safe Torque Off (STO), Safe Stop 1 (SS1-t)</li> <li>IEC 60204-1:2018 Stop Category 0, Stop Category 1</li> </ul>	

Table 26: Functional Safety Performance

Data	Value	
	STO, not upgradable (+BEF1)	STO, SS1-t, fieldbus (+BEF2)
<b>IEC 61508:2010</b>		
Safety Integrity Level	Up to SIL 3	Up to SIL 3
Maximum diagnostic test interval for related safety integrity level	SIL 3: 3 months	–
	SIL 2: 12 months	
Hardware Fault Tolerance (HFT)	1	1
Subsystem Classification	Type A	Type B
Average probability of dangerous failures on demand (PFDavg)	$<5 \cdot 10^{-4}$	$<1.5 \cdot 10^{-4(1)(2)}$
Average frequency of dangerous failures per hour (1/h) (PFH)	$<8 \cdot 10^{-9}$	$<7.5 \cdot 10^{-9(1)(2)}$
Proof Test Interval (T1)	20 years	20 years
Mission Time (TM)	20 years	20 years
<b>ISO 13849-1:2015</b>		
Category	Cat 3	Cat 3
Coverage of diagnostic (functional) test	>90%	>90%
Performance Level (PL)	Up to PL e	Up to PL e

**Table 26: Functional Safety Performance** (continued)

Data	Value	
	STO, not upgradable (+BEF1)	STO, SS1-t, fieldbus (+BEF2)
Maximum diagnostic test interval for related performance level	PL e: 3 months	–
	PL d: 12 months	–
Mean time to dangerous failure (MTTFd)	High (100 years per channel)	High (> 100 years)
Fault Reaction Time (FRT)	< 30 ms	< 40 ms
Response time (from input to safe state)	< 30 ms <sup>(3)</sup>	< 30 ms <sup>(3)</sup>
Mode of operation	High demand, Low demand	High demand, Low demand

1) At sea level

2) Proof tests can only be performed at Danfoss facilities when the drive is refurbished

3) Input to output response time with shielded cables. Otherwise, a maximum of 20 ms might be added to this value under worst case EMC conditions.

### 8.3.6.2 Functional Safety I/O

Control inputs and outputs are galvanically isolated from supply voltage (PELV) and other high voltage terminals, unless otherwise specified.

**Table 27: 24 V Digital Inputs on Safety I/O Terminal Blocks X31, X32**

Function	Data	
Digital input (single ended/floating)	Logic	PNP
	Voltage level	0–24 V DC
	Voltage level, logic 0 PNP	<5 V
	Voltage level, logic 1 PNP	>11 V
	Maximum voltage on input @functional	30 V
	Maximum voltage on input @ safe state	60 V
	Input current	8 mA > I <sub>c</sub> > 5 mA @ 24 V
	Equivalent input resistance	3 kΩ < Ri < 4.7 kΩ @ 24 V
	Isolation	Functional
	Reverse polarity protection	Yes
	Maximum input current off-state	< 2 mA

**Table 28: 24 V Digital Outputs for STO Feedback**

Function	Data
Output type	Sink/source
Voltage rating	24 V DC open collector / 60 V maximum
Current rating	50 mA
Isolation	Yes

**Table 28: 24 V Digital Outputs for STO Feedback** (continued)

Function	Data
Overload protection	Yes
Reverse polarity protection	Yes
ON state voltage	>17.4 V
Off state leakage current	0.1 mA

### 8.3.7 Interface Board

The interface board provides a connection to the control panel and the functional extension options in the frequency converter.

**Table 29: Interface Board Features**

Function	Data	
Memory card	Supported types	microSD, microSDHC, microSDXC
Real-time clock	Time format	<ul style="list-style-type: none"> <li>Year, month, day, weekday, hours, minutes, seconds</li> <li>Leap year correction</li> </ul>
	Precision	Better than 30 ppm/2.6 s/day
	Battery backup	Exchangeable Panasonic BR1632A (3 V, 125 °C) coin-cell battery. <sup>(1)</sup>
	Battery monitor	Yes
	Expected battery life	> 9 years, depending on temperature

1) Replace battery with Panasonic type BR1632A/DBN. Only qualified personnel can exchange the battery.

### 8.3.8 Ambient Conditions

#### 8.3.8.1 Overview

The frequency converter is designed for installation and use in weather-protected environments. The available protection ratings are:

- IP20/UL Open Type (frames FA02–FA12)
- IP21/UL Type 1 (frames FK06–FK12)
- IP54/IP55/UL Type 12 (frames FB09–FB12)

Conditions are given for:

- Transport (See [8.3.8.3 Ambient Conditions during Transport.](#))
- Storage (See [8.3.8.2 Ambient Conditions during Storage.](#))
- Operation (See [8.3.8.4 Ambient Conditions during Operation.](#))

#### 8.3.8.2 Ambient Conditions during Storage

The environments used as reference for the design criteria are described in standard IEC 60721-3-1:2019, unless otherwise specified.

References based on IEC/EN 61800-2 are given in parentheses.

**Table 30: Ambient Conditions during Storage**

Function	Data
Ambient temperature	-40...+55 °C (-40...+131 °F), 70 °C (158 °F) up to 4 months
Climatic condition	1K21 (1K4), maximum 95% non-condensing
Chemically active substances	1C2 (1C2)
Solid particles (nonconductive)	1S12 (1S12)
Vibration	1M11 (1M11)
Shock	1M11 (1M11)
Biological ambient	1B2 (1B12)

### 8.3.8.3 Ambient Conditions during Transport

The environments used as reference for the design criteria are described in standard IEC 60721-3-2:2018, unless otherwise specified. References based on IEC/EN 61800-2 are given in parentheses.

**Table 31: Ambient Conditions during Transport**

Function	Data
Ambient temperature	-40...+70 °C (-40...+158 °F)
Climatic condition	2K11 (2K2), maximum 95% non-condensing
Chemically active substances	2C2 (2C2)
Solid particles (nonconductive)	2S5 (2S5)
Vibration	2M5 (2M5)
Shock	2M5 (2M5)
	When installed on equipment: 2M4 (2M4)
Biological ambient	2B1 (2B1)

### 8.3.8.4 Ambient Conditions during Operation

The environments used as reference for the design criteria are described in standard IEC 60721-3-3:2019, unless otherwise specified. References based on IEC/EN 61800-2 are given in parentheses.

**Table 32: Ambient Conditions during Operation**

Function	Data
Ambient temperature	24 hour average: -30...+45 °C (-22...+113 °F) <sup>(1)</sup>
	1 hour operation: -30...+50 °C (-22...+122 °F) <sup>(1)</sup>
	With derating: -30...+60 °C (-22...+140 °F)
	In Fire mode: -30...+70 °C (-22... +158 °F)
Climatic condition	3K22 (3K3), maximum 95% non-condensing <sup>(2)</sup>

Table 32: Ambient Conditions during Operation (continued)

Function	Data
Chemically active substances	<ul style="list-style-type: none"> <li>• C3 (P1) Medium – non-coated drives (3C2)</li> <li>• C4 (P2) High – coated (3C3)                             <ul style="list-style-type: none"> <li>- IP20/UL Open Type and IP21/UL Type 1 installed in cabinet</li> <li>- IP54/IP55/UL Type 12</li> </ul> </li> </ul>
Solid particles (nonconductive)	3S6 (3S2)
Vibration	3M12 (3M4)
Shock	3M12 (3M4)
Biological ambient	3B1 (3B1)
Maximum altitude above sea level	Without derating: 1000 m (3300 ft)
	With derating: <ul style="list-style-type: none"> <li>• TN/TT (grounded) grids: 4400 m (14400 ft)</li> <li>• IT (ungrounded grids): 2000 m (6600 ft) for PELV compliance.</li> </ul>

1) The maximum temperature is 5 °C (9 °F) lower for frames Fx09–Fx12 in Low Overload mode.

2) Ensure maximum rate of change of temperature 0.1 °C/min to avoid condensation.

### 8.3.9 Discharge Times

Discharge time is the time required to discharge the DC-link capacitors of the drive after all external power sources have been disconnected.

Frame	Minimum waiting time (min)
Fx02–Fx03	5
Fx04–Fx08	15
Fx09–Fx10	20
Fx11–Fx12	40

## 8.4 Fuses and Circuit Breakers

### 8.4.1 Overview

For proper protection of the installation cable and the drive, fuses and/or circuit breakers must be used. Overcurrent protection devices must be installed as close to the drive as possible. If a short circuit occurs, fuses and circuit breakers protect the power cable and limit the damage to the frequency converter and components connected to the frequency converter.



## NOTICE

### EXCESSIVE HEAT AND PROPERTY DAMAGE

Overcurrent can generate excessive heat within the drive. Failure to provide overcurrent protection can result in risk of fire and property damage.

- Additional protective devices such as short-circuit protection or motor thermal protection between drive and motor is required for applications with multiple motors.
- Input fusing is required to provide short-circuit and overcurrent protection. If fuses are not factory-supplied, the installer must provide them. Refer to the product-specific documentation for fuse specifications.

The recommendations for fuses and circuit breakers must be followed to comply with relevant regulations. If recommendations are not followed, and problems occur, warranty may be affected.

See [8.4.2 IEC Compliant Fuses](#) for details on the short-circuit current rating for each drive type.

For further details, contact Danfoss, or refer to the installation guides.

### 8.4.2 IEC Compliant Fuses

To comply with IEC requirements, using gG and aR fuses is recommended, depending on drive rating. The fuse rating must not exceed the verification rating.

See [Table 33](#) and [Table 34](#) for the gG and aR fuses for protection against short circuit in the input power cable or drive. If the fuse type operates rapidly enough, either fuse type can be used for frames Fx02–Fx08. The operating time depends on the supply network impedance and the cross-sectional area and length of the supply cable. For frames Fx09–Fx12, only ultra-rapid (aR) fuses can be used.

**Table 33: Recommended IEC Compliant Fuses for IP20/UL Open Type Frames FA02–FA08 (Voltage Range 380–500 V)**

Product code <sup>(1)</sup>	Frame	Power [kW]	Recommended [A]	Tested with [A]	Fuse type	Minimum SCCR [kA]	Maximum SCCR [kA]
05-01A3	FA02	0.37	10	16	gG	0.2	100
05-01A8	FA02	0.55	10	16	gG	0.2	100
05-02A4	FA02	0.75	10	16	gG	0.2	100
05-03A0	FA02	1.1	10	16	gG	0.2	100
05-04A0	FA02	1.5	10	16	gG	0.2	100
05-05A6	FA02	2.2	10	16	gG	0.2	100
05-07A2	FA02	3	10	16	gG	0.2	100
05-09A2	FA02	4	16	20	gG	0.4	100
05-12A5	FA02	5.5	20	20	gG	0.5	100
05-16A0	FA03	7.5	25	25	gG	0.6	100
05-24A0	FA04	11	40	50	gG	1.0	100
05-31A0	FA04	15	50	50	gG	1.3	100
05-38A0	FA05	18.5	50	63	gG	1.3	100
05-43A0	FA05	22	63	63	gG	1.7	100
05-61A0	FA06	30	80	100	gG	2.2	100

**Table 33: Recommended IEC Compliant Fuses for IP20/UL Open Type Frames FA02–FA08 (Voltage Range 380–500 V) (continued)**

Product code <sup>(1)</sup>	Frame	Power [kW]	Recommended [A]	Tested with [A]	Fuse type	Minimum SCCR [kA]	Maximum SCCR [kA]
05-73A0	FA06	37	100	100	gG	2.6	100
05-90A0	FA07	45	125	160	gG	3.2	100
05-106A	FA07	55	160	160	gG	3.2	100
05-147A	FA08	75	200	224	gG	4.9	100
05-170A	FA08	90	224	224	gG	4.9	100

1) The product code consists of the mains voltage code and current rating code of the model code. For more information, see [12.2.1 Overview](#).

**Table 34: Recommended IEC Compliant Fuses for IP21/UL Type 1 Frames FK06–FK08 (Voltage Range 380–500 V)**

Product code <sup>(1)</sup>	Frame	Power [kW]	Recommended [A]	Tested with [A]	Fuse type	Minimum SCCR [kA]	Maximum SCCR [kA]
05-61A0	FK06	30	80	100	gG	2.2	100
05-73A0	FK06	37	100	100	gG	2.6	100
05-90A0	FK07	45	125	160	gG	3.2	100
05-106A	FK07	55	160	160	gG	3.2	100
05-147A	FK08	75	200	224	gG	4.9	100
05-170A	FK08	90	224	224	gG	4.9	100

1) The product code consists of the mains voltage code and current rating code of the model code. For more information, see [12.2.1 Overview](#).

**Table 35: Recommended IEC Compliant Fuses for Frames Fx09–Fx12 (Voltage Range 380–500 V)**

Product code <sup>(1)</sup>	Frame	Power [kW] (LO/HO)	Recommended fuse rating [A]	Tested with [A]	Fuse type	Maximum SCCR [kA]
05-206A	Fx09	110/90	315	400	aR	100
05-245A	Fx09	132/110	350		aR	100
05-302A	Fx09	160/132	400		aR	100
05-385A	Fx09	200/160	475	475	aR	100
05-395A	Fx10	200/160	630	800	aR	100
05-480A	Fx10	250/200	630		aR	100
05-588A	Fx10	315/250	800		aR	100
05-658A	Fx11	355/315	1000	1250	aR	100
05-736A	Fx11	400/355			aR	100
05-799A	Fx11	450/400	1250	1250	aR	100
05-893A	Fx12	500/450			aR	100
05-1000	Fx12	560/500			aR	100

**Table 35: Recommended IEC Compliant Fuses for Frames Fx09–Fx12 (Voltage Range 380–500 V)** (continued)

Product code <sup>(1)</sup>	Frame	Power [kW] (LO/HO)	Recommended fuse rating [A]	Tested with [A]	Fuse type	Maximum SCCR [kA]
05-1120	Fx12	630/560	1800	1800	aR	100
05-1260	Fx12	710/630			aR	100

1) The product code consists of the mains voltage code and current rating code of the model code. For more information, see [12.2.1 Overview](#).

### 8.4.3 UL Compliant Fuses

Danfoss products have been designed according to NEC 2023, and it is mandatory to use fuses or circuit breakers with the drives. Danfoss recommends using a selection of the fuses listed in [Table 36](#) and [Table 37](#). The fuses listed in the tables are suitable for use on a circuit capable of delivering 100 kA<sub>rms</sub> (symmetrical), 240 V, 480 V, 500 V, or 600 V depending on the drive voltage rating. With the proper fusing, the drive short-circuit current rating (SCCR) is 100 kA<sub>rms</sub>.

For semiconductor fuse types, the drive controller and overcurrent protection device must be integrated within the same overall assembly.

Fx09–Fx12 drives require the semiconductor fuses listed in [Table 38](#) to comply with UL requirements.

The fuse specifications apply only to external fuses.

Frames FK06–FK08 may be delivered with internal fuses and a disconnect. The disconnect reduces the maximum prospective short circuit rating to 65 kA. If the internal fuses need to be replaced, contact an authorized service partner.

#### NOTICE

##### DISCONNECT SWITCH SCCR REQUIREMENTS

All units ordered and supplied with a factory-installed disconnect switch (+AJDX) require a Class fuse for branch circuit protection to meet the 65 kA SCCR for the drive.

**Table 36: Recommended Maximum Fuses for IP20/UL Open Type Frames FA02–FA08 Installed in Cabinets (Voltage Range 3 x 380–500 V)**

Product code <sup>(1)</sup>	Frame	Power [kW]	Recommended [A]	Tested with [A]	Fuse type	Minimum external cabinet volume [l (cu ft.)]	Minimum SCCR [kA]	Maximum SCCR [kA]
05-01A3	FA02	0.37	4	15	RK5	52 (1.8)	0.02	100
05-01A8	FA02	0.55	6	15	RK5	52 (1.8)	0.1	100
05-02A4	FA02	0.75	8	15	RK5	52 (1.8)	0.1	100
05-03A0	FA02	1.1	10	15	RK5	52 (1.8)	0.2	100
05-04A0	FA02	1.5	10	15	RK5	52 (1.8)	0.2	100
05-05A6	FA02	2.2	10	15	RK5	52 (1.8)	0.2	100
05-07A2	FA02	3	10	15	RK5	52 (1.8)	0.2	100
05-09A2	FA02	4	15	20	RK5	52 (1.8)	0.3	100
05-12A5	FA02	5.5	20	20	RK5	52 (1.8)	0.5	100

**Table 36: Recommended Maximum Fuses for IP20/UL Open Type Frames FA02–FA08 Installed in Cabinets (Voltage Range 3 x 380–500 V) (continued)**

Product code <sup>(1)</sup>	Frame	Power [kW]	Recommended [A]	Tested with [A]	Fuse type	Minimum external cabinet volume [l (cu ft.)]	Minimum SCCR [kA]	Maximum SCCR [kA]
05-16A0	FA03	7.5	25	25	RK5	52 (1.8)	0.6	100
05-24A0	FA04	11	35	50	RK5	96 (3.4)	0.9	100
05-31A0	FA04	15	50	50	RK5	96 (3.4)	1.3	100
05-38A0	FA05	18.5	50	60	RK5	96 (3.4)	1.3	100
05-43A0	FA05	22	60	60	RK5	96 (3.4)	1.6	100
05-61A0	FA06	30	80	125	T/J	192 (6.8)	2.2	100
05-73A0	FA06	37	100	125	T/J	192 (6.8)	2.6	100
05-90A0	FA07	45	125	200	T/J	240 (8.5)	3.2	100
05-106A	FA07	55	150	200	T/J	240 (8.5)	3.8	100
05-147A	FA08	75	200	225	T/J	288 (10.2)	4.9	100
05-170A	FA08	90	225	225	T/J	288 (10.2)	6.1	100

1) The product code consists of the mains voltage code and current rating code of the model code. For more information, see [12.2.1 Overview](#).

**Table 37: Recommended Maximum Fuses for IP21/UL Type 1 Frames FK06–FK08 (Voltage Range 3 x 380–500 V)**

Product code <sup>(1)</sup>	Frame	Power [kW]	Recommended [A]	Tested with [A]	Fuse type	Minimum SCCR [kA]	Maximum SCCR [kA]
05-61A0	FK06	30	80	125	T/J	2.2	100
05-73A0	FK06	37	100	125	T/J	2.6	100
05-90A0	FK07	45	125	200	T/J	3.2	100
05-106A	FK07	55	150	200	T/J	3.8	100
05-147A	FK08	75	200	225	T/J	4.9	100
05-170A	FK08	90	225	225	T/J	6.1	100

**Table 38: Recommended UL Compliant Fuses for Fx09-Fx12 Frames**

Product code <sup>(1)</sup>	Frame	Power [kW] (LO/HO)	Recommended Fuse rating [A]	Tested with [A]	Fuse type	Bussmann PN	Maximum SCCR [kA]
05-206A	Fx09	110/90	315	400	aR	170M2619	100
05-245A	Fx09	132/110	350		aR	170M2620	100
05-302A	Fx09	160/132	400		aR	170M2621	100
05-385A	Fx09	200/160	475	475	aR	170M9007	100

**Table 38: Recommended UL Compliant Fuses for Fx09-Fx12 Frames** (continued)

Product code <sup>(1)</sup>	Frame	Power [kW] (LO/HO)	Recommended Fuse rating [A]	Tested with [A]	Fuse type	Bussmann PN	Maximum SCCR [kA]
05-395A	Fx10	200/160	630	800	aR	170M4016	100
05-480A	Fx10	250/200	630		aR	170M4016	100
05-588A	Fx10	315/250	800		aR	170M4017	100
05-658A	Fx11	355/315	1000	1250	aR	170M6014	100
05-736A	Fx11	400/355			aR		100
05-799A	Fx11	450/400	1250	1250	aR	170M7309	100
05-893A	Fx12	500/450			aR		100
05-1000	Fx12	560/500			aR		100
05-1120	Fx12	630/560	1800	1800	aR	170M7340	100
05-1260	Fx12	710/630			aR		100

The fuses listed in [Table 38](#) are suitable for use on a circuit capable of delivering 100 kA<sub>rms</sub> (symmetrical), depending on the drive voltage rating. With the proper fusing, the drive short-circuit current rating (SCCR) is 100 kA<sub>rms</sub>. Frames FK09–FK12 and FB09–FB12 are supplied with internal drive fusing to meet the 100 kA SCCR. Frames FA09–FA12 must be fitted with Type aR fuses to meet the 100 kA SCCR.

### NOTICE

#### DISCONNECT SWITCH SCCR REQUIREMENTS

All units ordered and supplied with a factory-installed disconnect switch (+AJFD) require a Class fuse for branch circuit protection to meet the 100 kA SCCR for the drive.

If a circuit breaker is used, the SCCR rating is less than 100 kA.

- The product code of the drive determines the specific Class fuse. The product code is stated on the product label.
- For more details on the fuses and circuit breakers, see [Table 39](#).

**Table 39: Disconnect Switch SCCR Requirements for Fx09–Fx12 Frames (380–500 V Input Voltage)**

Product code <sup>(1)</sup>	Short circuit rating (kA)	Required protection
05-206A	30	Circuit breaker
	100	Class J fuse, 600A
05-245A	30	Circuit breaker
	100	Class J fuse, 600A
05-302A	30	Circuit breaker
	100	Class J fuse, 600A
05-395A	30	Circuit breaker
	100	Class J, T, L fuse, 800A

Table 39: Disconnect Switch SCCR Requirements for Fx09–Fx12 Frames (380–500 V Input Voltage) (continued)

Product code <sup>(1)</sup>	Short circuit rating (kA)	Required protection
05-480A	30	Circuit breaker
	100	Class J, T, L fuse, 800A
05-588A	30	Circuit breaker
	100	Class J, T, L fuse, 800A
05-658A	42	Circuit breaker
	100	Class L fuse, 800A
05-736A	42	Circuit breaker
	100	Class L fuse, 800A
05-799A	42	Circuit breaker
	100	Class L fuse, 800A
05-893A	42	Circuit breaker
	100	Class L fuse, 1200A
05-1000	42	Circuit breaker
	100	Class L fuse, 1200A

#### 8.4.4 IEC Compliant Circuit Breakers

Recommended circuit breakers are listed in [Table 40](#). If the circuit breaker limits the energy into the drive to a level equal to or lower than the recommended types, other types of circuit breakers can be used. Use a fuse in series with the circuit breaker, or install the frequency converter in a cabinet.

Table 40: Recommended Circuit Breakers for IEC Compliant Installation in IP20/UL Open Type Frames

Product code <sup>(1)</sup>	Frame	Manufacturer and model	SCCR [kA] <sup>(2)</sup>
05-01A3	FA02	ABB S203P-C16	25
05-01A8		ABB S203P-C16	25
05-02A4		ABB S203P-C16	25
05-03A0		ABB S203P-C16	25
05-04A0		ABB S203P-C16	25
05-05A6		ABB S203P-C16	25
05-07A2		ABB S203P-C16	25
05-09A2		ABB S203P-C20	25
05-12A5		ABB S203P-C20	25
05-16A0	FA03	ABB S203P-C25	25

**Table 40: Recommended Circuit Breakers for IEC Compliant Installation in IP20/UL Open Type Frames** (continued)

Product code <sup>(1)</sup>	Frame	Manufacturer and model	SCCR [kA] <sup>(2)</sup>
05-24A0	FA04	ABB S203P-C50	15
05-31A0		ABB S203P-C50	15
05-38A0	FA05	ABB S203P-C63	15
05-43A0		ABB S203P-C63	15

1) The product code consists of the mains voltage code and current rating code of the model code. For more information, see [12.2.1 Overview](#).

2) Maximum allowed short-circuit rating of the power supply (IEC 61800-5-1)

### 8.4.5 UL Compliant Circuit Breakers and Combination Motor Controllers

In UL compliant installations, the circuit breaker must be used with a fuse in series, and a combination motor controller (CMC) is suitable as branch circuit protection by itself. The short-circuit current rating (SCCR) must comply with the rating given in [Table 41](#).

**Table 41: Recommended Circuit Breakers for UL Compliant Installation in IP20/UL Open Type Frames**

Product code <sup>(1)</sup>	Frame	Manufacturer and model	Maximum trip level [A]	Ratings	Minimum external cabinet volume [l (cu ft.)]
05-01A3	FA02	ABB MS165-16	16	CMC Type E (480Y/277 V AC) 65 kA	52 (1.8)
05-01A8		ABB MS165-16	16	CMC Type E (480Y/277 V AC) 65 kA	52 (1.8)
05-02A4		ABB MS165-16	16	CMC Type E (480Y/277 V AC) 65 kA	52 (1.8)
05-03A0		ABB MS165-16	16	CMC Type E (480Y/277 V AC) 65 kA	52 (1.8)
05-04A0		ABB MS165-16	16	CMC Type E (480Y/277 V AC) 65 kA	52 (1.8)
05-05A6		ABB MS165-16	16	CMC Type E (480Y/277 V AC) 65 kA	52 (1.8)
05-07A2		ABB MS165-16	16	CMC Type E (480Y/277 V AC) 65 kA	52 (1.8)
05-09A2		ABB MS165-20	20	CMC Type E (480Y/277 V AC) 65 kA	52 (1.8)
05-12A5		ABB MS165-20	20	CMC Type E (480Y/277 V AC) 65 kA	52 (1.8)
05-16A0		FA03	ABB MS165-25	25	CMC Type E (480Y/277 V AC) 65 kA
05-24A0	FA04	ABB MS165-42	42	CMC Type E (480Y/277 V AC) 65 kA	96 (3.4)
05-31A0		ABB MS165-42	42	CMC Type E (480Y/277 V AC) 65 kA	96 (3.4)
05-38A0	FA05	ABB MS165-54	54	CMC Type E (480Y/277 V AC) 65 kA	96 (3.4)
05-43A0		ABB MS165-54	54	CMC Type E (480Y/277 V AC) 65 kA	96 (3.4)

1) The product code consists of the mains voltage code and current rating code of the model code. For more information, see [12.2.1 Overview](#).

### 8.4.6 Protection of DC Interface

The DC interface of the frequency converter is used in some configurations only, for example:

- Load sharing

- Supply from another frequency converter
- DC supply

For more information on load sharing, see *Use of DC Connections in iC7-Automation Frequency Converters Application Guide*.

The protection measures vary based on the setup. For further information and guidance on use, contact Danfoss.

## 8.5 Power Connectors

To ensure proper operation, observe the cross-section dimensions, stripping length, and tightening torques.

The dimensions apply to both solid and stranded cables. Unless otherwise specified, the specifications apply to IP20/UL Open Type, IP21/UL Type 1, and IP54/IP55/UL Type 12 frames. Drives are designed for use of 70 °C (158 °F) rated copper cables for frames up to Fx07. For Fx08–Fx12, 90 °C (194 °F) rated copper cable is recommended. If nothing else is stated, the ambient temperature of the drive matches the cable rating. Aluminum cables can be used from 35 mm<sup>2</sup> onwards. Proper connections must be secured by removing the oxide layer and applying joint compound.

For frames Fx02–Fx06, the same specifications apply to mains, motor, and brake cables. For frames Fx07–Fx12, the specifications differ for each cable type. The maximum number of cables is also stated for frames Fx09–Fx12.

### NOTICE

Using a cable with the maximum allowed cross-section requires more effort during the installation.

Table 42: Power Cable Sizing

Frame	Terminal	Cross-section [mm <sup>2</sup> (AWG)] <sup>(1)</sup>	Torque [Nm (in-lb)]	Stripping length [mm (in)]	Connector type	Screw/Lug type
Fx02	All	0.2–6 (24–10)	0.7 (6.2) <sup>(2)</sup>	10 (0.4)	Pluggable terminal	SL1/PZ1
Fx03	All	0.2–6 (24–10)	0.7 (6.2)	10 (0.4)	Pluggable terminal	SL1/PZ1
Fx04	All	6–16 (10–6)	1.2–1.5 (17)	15 (0.6)	Pluggable terminal	SL1/T15
Fx05	All	10–25 (8–4)	2.0–2.5 (26)	22 (0.9)	Pluggable terminal	SL2/T20
Fx06	All	16–35 <sup>(3)</sup> /50 <sup>(4)</sup> (6–2/1)	14 (124)	17 (0.7)	Terminal	T30
Fx07	Mains and motor	35–70 <sup>(3)</sup> /95 <sup>(4)</sup> [(2/0)/(3/0)]	14 (124)	22 (0.9)	Terminal	T30
	Brake and DC connection	16–35 <sup>(3)</sup> /50 <sup>(4)</sup> (6–2/1)	14 (124)	17 (0.7)	Terminal	T30
Fx08	Mains and motor	50–120 <sup>(3)</sup> / 150 <sup>(4)</sup> (1 – (4/0)/(300MCM))	20 (177)	29 (1.1)	Terminal	T50
	Brake and DC connection	35–70 <sup>(3)</sup> /95 <sup>(4)</sup> [(2/0)/(3/0)]	14 (124)	22 (0.9)	Terminal	T30
Fx09	Mains and motor	2x120 (2x4/0)	19 (168)	–	M10 bolt	Cable lug
	Brake and DC connection	2x120 (2x4/0)	19 (168)	–	M10 bolt	Cable lug



Table 42: Power Cable Sizing (continued)

Frame	Terminal	Cross-section [mm <sup>2</sup> (AWG)] <sup>(1)</sup>	Torque [Nm (in-lb)]	Stripping length [mm (in)]	Connector type	Screw/Lug type
Fx10	Mains and motor	2x240 (2x400 MCM)	19 (168)	–	M10 bolt	Cable lug
	Brake and DC connection	2x240 (2x400 MCM)	19 (168)	–	M10 bolt	Cable lug
FA11	Mains and motor	6x240 (6x500 MCM)	19 (168) / 35 (310)	–	M10 bolt/M12 bolt	Cable lug
	Brake	2x185 (2x350 MCM)	19 (168)	–	M10 bolt	Cable lug
FK11/ FB11	Mains and motor without brake	5x240 (5x500 MCM)	19 (168) / 35 (310)	–	M10 bolt/M12 bolt	Cable lug
	Mains and motor with brake	4x240 (4x500 MCM)	19 (168) / 35 (310)	–	M10 bolt/M12 bolt	Cable lug
	Brake	2x185 (2x350 MCM)	19 (168)	–	M10 bolt	Cable lug
FA12	Mains and motor	6x240 (6x500 MCM)	19 (168) / 35 (310)	–	M10 bolt/M12 bolt	Cable lug
	Brake	2x185 (2x350 MCM)	19 (168)	–	M10 bolt	Cable lug
FK12/ FB12	Mains and motor without brake	6x240 (6x500 MCM)	19 (168) / 35 (310)	–	M10 bolt/M12 bolt	Cable lug
	Mains and motor with brake	5x240 (5x500 MCM)	19 (168) / 35 (310)	–	M10 bolt/M12 bolt	Cable lug
	Brake	2x185 (2x350 MCM)	19 (168)	–	M10 bolt	Cable lug

1) For frames Fx09–Fx12, the maximum number and size of cables per phase is also stated.

2) 0.5–0.6 Nm ≤ 4 mm<sup>2</sup>; 0.7 Nm > 4 mm<sup>2</sup>; 4.4–5.3 in-lb ≤ AWG 24–12; 6.2 Nm > AWG 11–10

3) Connectable conductor cross-section, fine-strand with cable end sleeve

4) Connectable conductor cross-section, multi-wired

## 8.6 Cooling and Power Loss

### 8.6.1 Power Loss

The frequency converter dissipates heat due to power loss when powered on and running. The main heat dissipating sources are:

- Heat sink (cooling of IGBT and SCRs)
- DC link inductor
- DC link capacitors
- Busbars (applicable for Fx09-Fx12)

The frequency converters can be mounted side by side, and a speed-controlled fan is used for forced cooling.

The power losses of the frequency converter are listed in [Table 43](#). Power loss data at other operating points according to IEC 61800-9-2 is available in MyDrive® ecoSmart™.

Table 43: Power Loss by Unit

Product code <sup>(1)</sup>	Low overload		High overload		High overload with increased duty	
	$P_{typ}^{(2)}$ [W]	$P_{max}^{(3)}$ [W]	$P_{typ}^{(2)}$ [W]	$P_{max}^{(3)}$ [W]	$P_{typ}^{(2)}$ [W]	$P_{max}^{(3)}$ [W]
05-01A3	26	31	26	31	24	27
05-01A8	29	36	29	36	26	31
05-02A4	31	44	31	44	29	36
05-03A0	35	52	35	52	32	45
05-04A0	40	67	40	67	37	58
05-05A6	50	83	50	83	43	66
05-07A2	59	105	59	105	49	82
05-09A2	69	126	69	126	63	109
05-12A5	76	175	76	175	71	130
05-16A0	92	221	92	221	77	171
05-24A0	128	315	128	315	95	207
05-31A0	162	397	162	397	133	305
05-38A0	197	484	197	484	169	391
05-43A0	220	541	220	541	195	462
05-61A0	269	650	269	650	207	460
05-73A0	320	817	320	817	269	647
05-90A0	406	992	406	992	344	766
05-106A	461	1204	461	1204	395	977
05-147A	659	1682	659	1682	499	1155
05-170A	708	1845	708	1845	620	1546
05-206A	976	2316	827	1867	738	1604
05-245A	1114	2651	955	2172	817	1771
05-302A	1369	3438	1118	2658	959	2180
05-385A	1648	4053	1357	3041	1139	2434
05-395A	1764	4061	1445	3029	1233	2468
05-480A	2117	5123	1732	3969	1453	3052
05-588A	2570	6348	2111	4975	1733	3889
05-658A	3235	7576	2940	6698	2500	5433

**Table 43: Power Loss by Unit** (continued)

Product code <sup>(1)</sup>	Low overload		High overload		High overload with increased duty	
	P <sub>typ</sub> <sup>(2)</sup> [W]	P <sub>max</sub> <sup>(3)</sup> [W]	P <sub>typ</sub> <sup>(2)</sup> [W]	P <sub>max</sub> <sup>(3)</sup> [W]	P <sub>typ</sub> <sup>(2)</sup> [W]	P <sub>max</sub> <sup>(3)</sup> [W]
05-736A	3578	8553	3242	7539	2948	6676
05-799A	3854	9339	3400	7962	3242	7495
05-893A	4438	10547	4045	9321	3788	8538
05-1000	4869	11823	4357	10207	4022	9179
05-1120	5152	13354	4622	11638	4164	10197
05-1260	5772	15402	5042	12981	4602	11564

1) The product code consists of the mains voltage code and current rating code of the model code. For more information, see [12.2.1 Overview](#).

2) Absolute power loss at 50% rated output frequency, and 50% of rated torque

3) Absolute power loss at 100% rated output frequency, and 100% of rated torque

## 8.6.2 Airflow and Noise Levels

To ensure proper cooling of the drive, proper flow of air is needed. The values state the maximum flow at full fan speed for the respective frames.

During operation, the drive emits noise. The sound pressure level depends on the size of the drive, the actual load, and surrounding conditions. The main source of the noise is the cooling fan of the drive. For Fx09-Fx12 frames airflow data is stated both for the heat sink fan and top or door fan. The heat sink fan is the main fan providing airflow over the heat sink, and the top or door fan provide additional airflow in the control electronics.

Follow local regulations on the working environment and the protection of personnel regarding acoustic noise levels.

**Table 44: Airflow and Noise Levels for IP20/UL Open Type Frames (FA02–FA12)**

Frame	Airflow (m <sup>3</sup> /h [cfm])		Noise level dB(A)		
	Heat sink fan	Top/door fan	40% fan speed	80% fan speed	100% fan speed
FA02	50 (29)	–	41	49	52
FA03	100 (59)	–	35	50	56
FA04	165 (97)	–	40	55	59
FA05	280 (165)	–	46	61	65
FA06	280 (165)	–	46	57	62
FA07	280 (165)	–	50	64	71
FA08	370 (218)	–	54	65	71
FA09	638 (375)	150 (88)	63	75	78
FA10	638 (375)	150 (88)	57	72	79
FA11	994 (585)	660 (390)	61	71	76
FA12	1206 (710)	660 (390)	62	74	78

**Table 45: Airflow and Noise Levels for IP21/UL Type 1 Frames (FK06–FK12)**

Frame	Airflow (m <sup>3</sup> /h [cfm])		Noise level dB(A)		
	Heat sink fan	Top/door fan	40% fan speed	80% fan speed	100% fan speed
FK06	280 (165)	–	46	57	62
FK07	280 (165)	–	50	64	71
FK08	370 (218)	–	54	65	71
FK09	638 (375)	144 (85)	57	73	77
FK10	638 (375)	204 (120)	57	72	79
FK11	994 (585)	595 (350)	63	73	79
FK12	1206 (710)	1020 (600)	71	75	79

**Table 46: Airflow and Noise Levels for IP54/UL Type 12 Frames (FB09–FB12)**

Frame	Airflow (m <sup>3</sup> /h [cfm])		Noise level dB(A)		
	Heat sink fan	Top/door fan	40% fan speed	80% fan speed	100% fan speed
FB09	638 (375)	144 (85)	57	73	77
FB10	638 (375)	204 (120)	57	72	79
FB11	994 (585)	595 (350)	63	73	79
FB12	1206 (710)	1020 (600)	71	75	79

## 8.7 Energy Efficiency Data

The iC7 drives are designed according to the requirements in IEC61800-9-2 and are all compliant to efficiency class IE2. Relative loss for the drive is stated on the product label.

The IE class for AC drives is determined in a single operation point at 100% current and 90% output frequency. The losses include EMC filters and brake choppers, for example, and are determined as factory settings.

For detailed information, refer to the MyDrive ecoSmart tool (<https://ecosmart.mydrive.danfoss.com>).

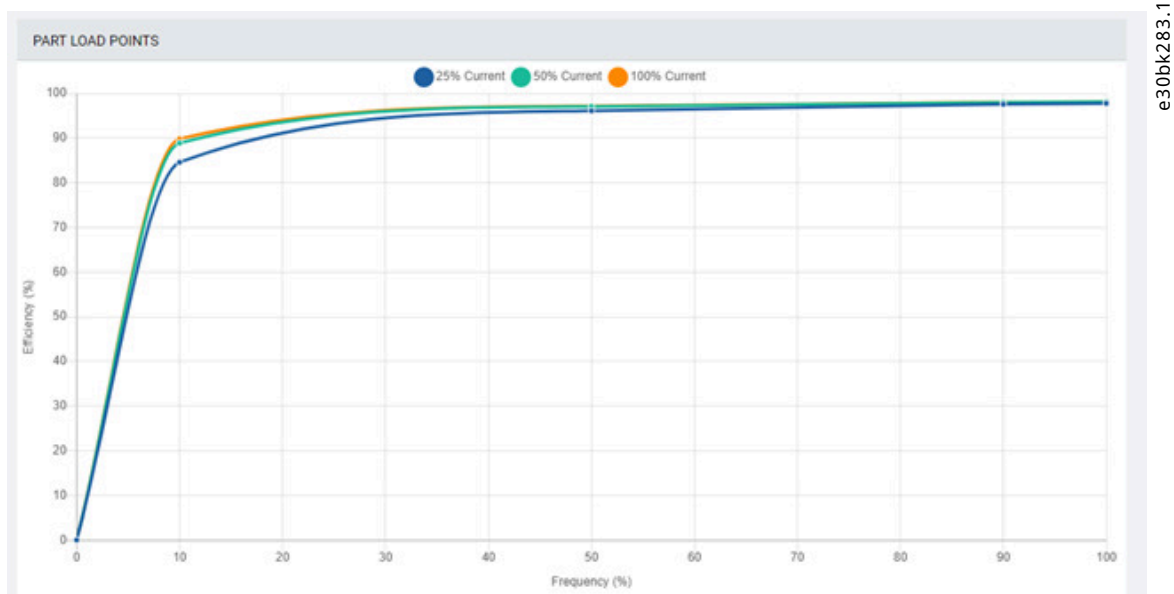

e30bk283.1c

Figure 9: Example of MyDrive® ecoSmart™ data

## 8.8 Packaging

Depending on the frame, the drives are shipped in simple cardboard packaging or secured to a wooden pallet.

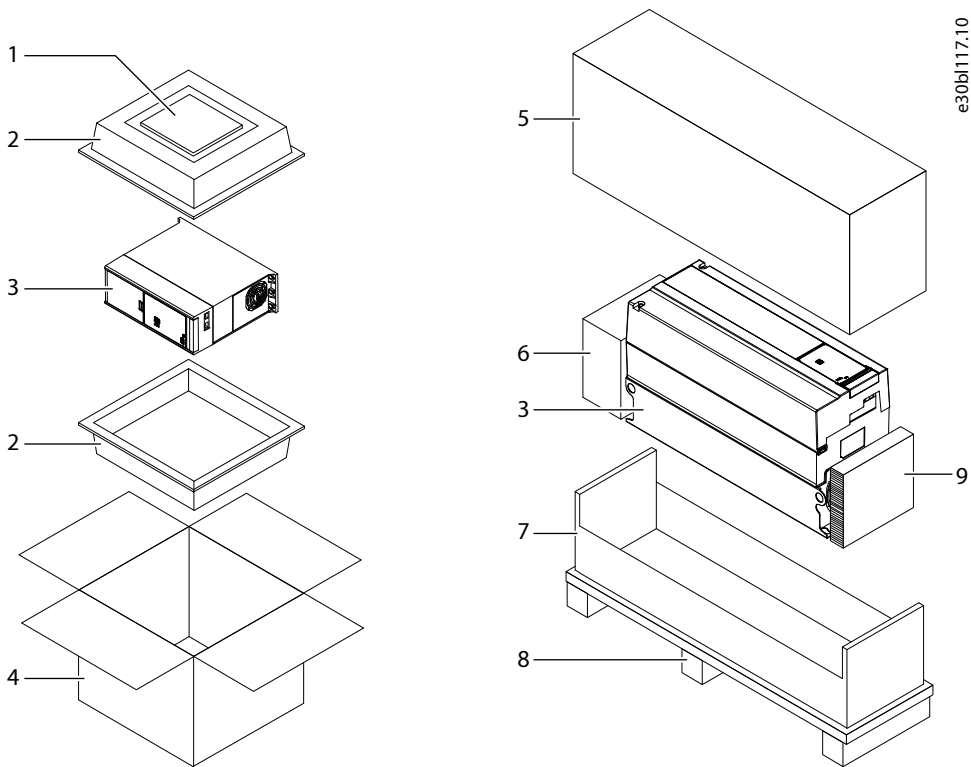

1	Installation and safety guides and accessory bag	2	Insert
3	Drive	4	Cardboard box
5	Cardboard cover	6	Accessory box
7	Cardboard tray	8	Pallet
9	Spacer		

Figure 10: Type A Packaging for Frames Fx02-Fx05 (Left) and Type B Packaging for Frames Fx06-Fx08 (Right)

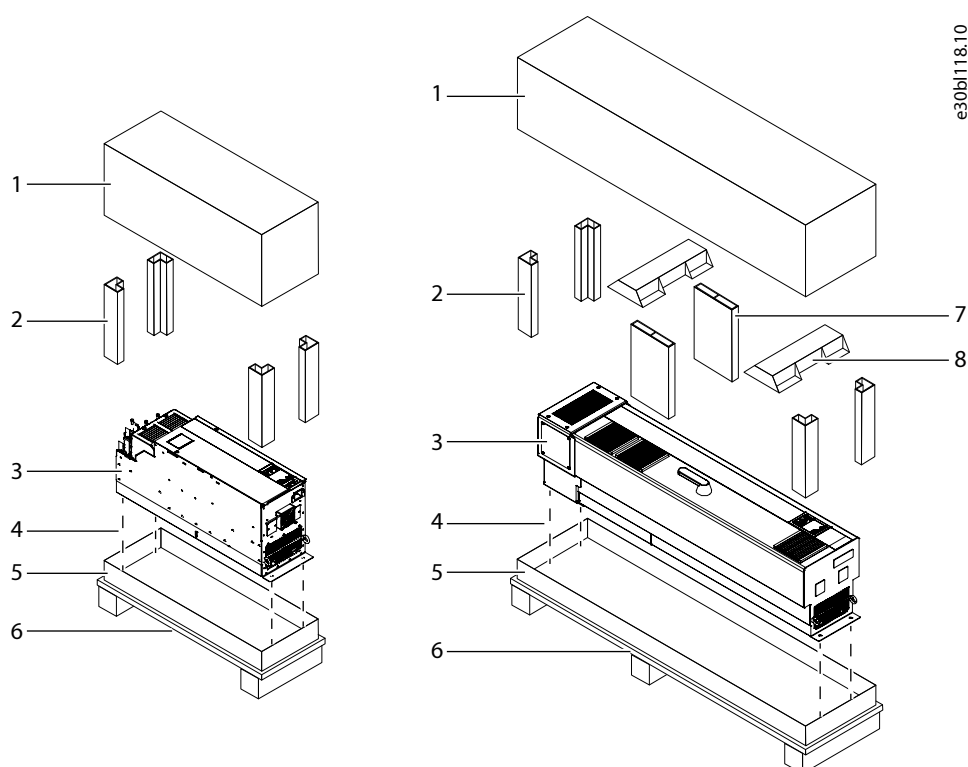

1	Cardboard cover	2	Corner spacers
3	Drive	4	Mounting screws to secure the drive to the pallet
5	Cardboard tray	6	Pallet
7	Side spacers	8	Top spacers

Figure 11: Type C Packaging for Frames FA09-FA12, FK09a, FK10a, FK11, and FK12 (Left) and Type D Packaging for Frames FK09c and FK10c (Right)

The packaging dimensions and weight depend on the frame. The weight given in the tables is the maximum weight of the drive shipment. Specific weights for each frame are also listed in Danfoss Product Configuration Tool.

Table 47: Package Dimensions for IP20/UL Open Type Frames

Frame	Height [mm (in)]	Width [mm (in)]	Depth [mm (in)]	Weight [kg (lb)]	Packaging concept
FA02a	196 (7.76)	320 (12.6)	330 (13)	5.25 (11.6)	A
FA02b	196 (7.76)	320 (12.6)	330 (13)	5.5 (12.1)	A
FA03a	220 (8.66)	320 (12.6)	330 (13)	6.15 (13.6)	A
FA03b	220 (8.66)	320 (12.6)	330 (13)	6.45 (14.2)	A
FA04a	291 (11.5)	394 (15.5)	544 (21.4)	12.6 (27.8)	A
FA04b	291 (11.5)	394 (15.5)	544 (21.4)	12.8 (28.2)	A
FA05a	326 (12.8)	394 (15.5)	544 (21.4)	15.1 (33.2)	A
FA05b	326 (12.8)	394 (15.5)	544 (21.4)	15.6 (34.3)	A
FA06	271 (10.67)	434 (17.09)	731 (28.8)	26 (57)	B
FA07	294 (11.6)	471 (18.53)	801 (31.5)	38 (84)	B

**Table 47: Package Dimensions for IP20/UL Open Type Frames** (continued)

Frame	Height [mm (in)]	Width [mm (in)]	Depth [mm (in)]	Weight [kg (lb)]	Packaging concept
FA08	492 (19.4)	382 (15.04)	1048 (41.3)	62 (137)	B
FA09	559 (22)	991 (39)	457 (18)	94 (208)	C
FA10	559 (22)	1194 (47)	546 (21.5)	143 (315)	C
FA11	757 (29.8)	1760 (69.3)	793 (31.2)	281 (620)	C
FA12	757 (29.8)	1760 (69.3)	793 (31.2)	357 (787)	C

**Table 48: Package Dimensions for IP21/UL Type 1 Frames**

Frame	Height [mm (in)]	Width [mm (in)]	Depth [mm (in)]	Weight [kg (lb)]	Packaging concept
FK06	271 (10.67)	434 (17.09)	731 (28.8)	28 (61)	B
FK07	294 (11.6)	471 (18.53)	801 (31.5)	38 (84)	B
FK08	492 (19.4)	382 (15.04)	1048 (41.3)	70 (154)	B
FK09a	559 (22)	1168 (46)	457 (18)	104 (229)	C
FK09c	533 (21)	1829 (72)	559 (22)	128 (282)	D
FK10a	559 (22)	1397 (55)	559 (22)	158 (348)	C
FK10c	559 (22)	2388 (94)	610 (24)	208 (458)	D
FK11	767 (30.2)	2191 (86.3)	871 (34.3)	294 (648)	C
FK12	767 (30.2)	2191 (86.3)	871 (34.3)	380 (838)	C

**Table 49: Package Dimensions for IP54/IP55/UL Type 12 Frames**

Frame	Height [mm (in)]	Width [mm (in)]	Depth [mm (in)]	Weight [kg (lb)]	Packaging concept
FB09a	559 (22)	1168 (46)	457 (18)	104 (229)	C
FB09c	533 (21)	1829 (72)	559 (22)	128 (282)	D
FB10a	559 (22)	1397 (55)	559 (22)	158 (348)	C
FB10c	559 (22)	2388 (94)	610 (24)	208 (458)	D
FB11	767 (30.2)	2191 (86.3)	871 (34.3)	294 (648)	C
FB12	767 (30.2)	2191 (86.3)	871 (34.3)	380 (838)	C

## 8.9 Cable Length

The drive supports using cable lengths up to 300 m (984 ft). See [Table 50](#) for details on the lengths of the different cable types.

For EMC compliance and filters, see [8.10.1 EMC Compliance Levels](#).



Table 50: Cable Lengths

Cable type	Maximum length [m (ft)]
Motor cable <sup>(1)</sup>	Shielded: 300 (984) For EMC compliance, see <a href="#">Table 52</a> .
	Unshielded: 300 (984)
Brake cable (R+, R-)	10 (33)
DC cable (+DC, -DC)	See <i>Use of DC Connections in iC7-Automation Frequency Converters Application Guide</i> .
Control Panel	10 (33) <sup>(2)</sup>

1) The maximum length depends on the EMC filter and cable type.

2) Use the Control Panel Cable, available in 2.5 m (8 ft), 5 m (16 ft), and 10 m (33 ft).

## 8.10 EMC

### 8.10.1 EMC Compliance Levels

The drives are designed and tested to comply with relevant EMC standards. The performance level depends on the actual drive and selected EMC compliance level.

The EMC compliance levels are tested under the following conditions:

- The drive (with options if relevant)
- Shielded control and communication cables
- External control with digital I/O and analog control
- Single motor connected with shielded cable: Lapp Ölflex Classic 100CY (single cable) for Fx02–Fx08, and Helukabel Top Serv 109 for Fx09–Fx12
- Load share and brake cables
- Standard drive settings

## NOTICE

According to the EMC Directive, a system is defined as a combination of several types of equipment, finished products, and/or components combined, designed and/or put together by the same person (system manufacturer) intended to be placed on the market for distribution as a single functional unit for an end user and intended to be installed and operated together to perform a specific task.

The EMC directive applies to products/systems and installations, but in case the installation is built up of CE-marked products/systems, the installation can also be considered compliant with the EMC directive. Installations are not CE-marked.

According to the EMC Directive, as a manufacturer of products/systems is responsible for obtaining the essential requirements of the EMC directive and attaching the CE mark. For systems involving load sharing and other DC terminals, can only ensure compliance with the EMC Directive when combinations of products are connected as described in the technical documentation.

If any third-party products are connected to the load share or other DC terminals on the AC drives, cannot guarantee that the EMC requirements are fulfilled.

If installed in residential environments, and not compliant to category C1, the drive may not provide adequate protection to radio reception in such locations. In such cases supplementary mitigation measures might be required, for example, the use of shielding or increasing the distance between affected products.

If not compliant to category C1 or C2, the drive must not be installed in a public low voltage network, which supplies residential premises. Radio frequency interference can be expected if used on such a network. Follow the instructions for installation given in the product-specific installation guide.

If the RFI filters of the drive are disabled, the drive fulfills category C4. In this case the drive is intended to be used in an installation powered by a supply which does not radiate, for example a dedicated transformer or generator, or low voltage underground lines. If guidelines for installation are not followed carefully, radio frequency interference can be expected.

### 8.10.2 Emission Requirements

According to the EMC product standard for AC drives, EN/IEC 61800-3, the EMC requirements depend on the intended use of the drive. Four categories are defined in the EMC product standard. The definitions of the 4 compliance categories are given in [Table 51](#).

**Table 51: Compliance Category and Intended Use of the Drive**

Compliance category	Intended use of the drive
C1	Drives installed in residential, commercial, or light industrial locations, with a supply voltage less than 1000 V.
C2	Drives with a supply voltage less than 1000 V, which are neither plug-in nor movable and are not intended for use in residential locations. If installed in commercial or light industrial locations, it is intended to be installed and commissioned by a professional.
C3	Drives installed in industrial locations and not intended for use in residential, commercial, or light industrial locations, with a supply voltage lower than 1000 V.
C4	Drives installed in complex systems in an industrial location, or with a supply voltage equal to or above 1000 V, or rated currents equal to or above 400 A.

The drives are designed to comply with 1 of the following 4 categories, defined in the EMC product standard, EN/IEC 61800-3.

Table 52: EMC Emission Compliance Levels at Maximum Motor Cable Length

EMC category (model code)	Frame	EN/IEC 61800-3 compliance category					
		Conducted emission			Radiated emission		
		C1	C2	C3	C1	C2	C3
		Cable length [m (ft)]					
F1 – Combined C1 and C2 filter	Fx02–Fx08	50 (164)	150 (492)	150 (492)	No	Yes	Yes
F2 – C2 filter	Fx02–Fx08	-	150 (492)	150 (492)	No	Yes	Yes
	Fx09–Fx12	-	150 (492)	150 (492)	No	Yes	Yes
F3 – C3 filter	Fx02–Fx05	-	-	250 (820)	No	No	Yes
	Fx06–Fx08	-	-	300 (984)	No	No	Yes
	Fx09–Fx12	-	-	150 (492)	No	No	Yes
F4 – No filter	Fx02–Fx12	-	-	-	No	No	No

For frames Fx02–Fx08 emission levels are measured with a single motor cable, and do not apply for parallel motor cables. Using cables that are longer than the specified maximum length can result in exceeding emission level limits.

### 8.10.3 Immunity Requirements

The frequency converters are specified and tested to comply with industrial requirements for electromagnetic immunity. Compliance with domestic limits is fulfilled with a safety margin, as the immunity requirements are lower than for industrial installations.

## 9 Exterior and Terminal Dimensions

### 9.1 Overview

The drawings included in the design guide provide the main dimensions of the different frames. See [10.8.5 Recommended Fasteners](#) for the maximum weights of each frame.

The drawings are general drawings and can contain details that are not relevant for the shipped drive. All drawings are in first angle projection. For frames Fx06–Fx12, the center of gravity is shown in the drawings.

The drawings are also available at <https://www.danfoss.com/en/service-and-support/documentation/> in various formats, for example, as .stp files.

## 9.2 IP20/UL Open Type Frames (FA02-FA12)

### 9.2.1 FA02a Dimensions

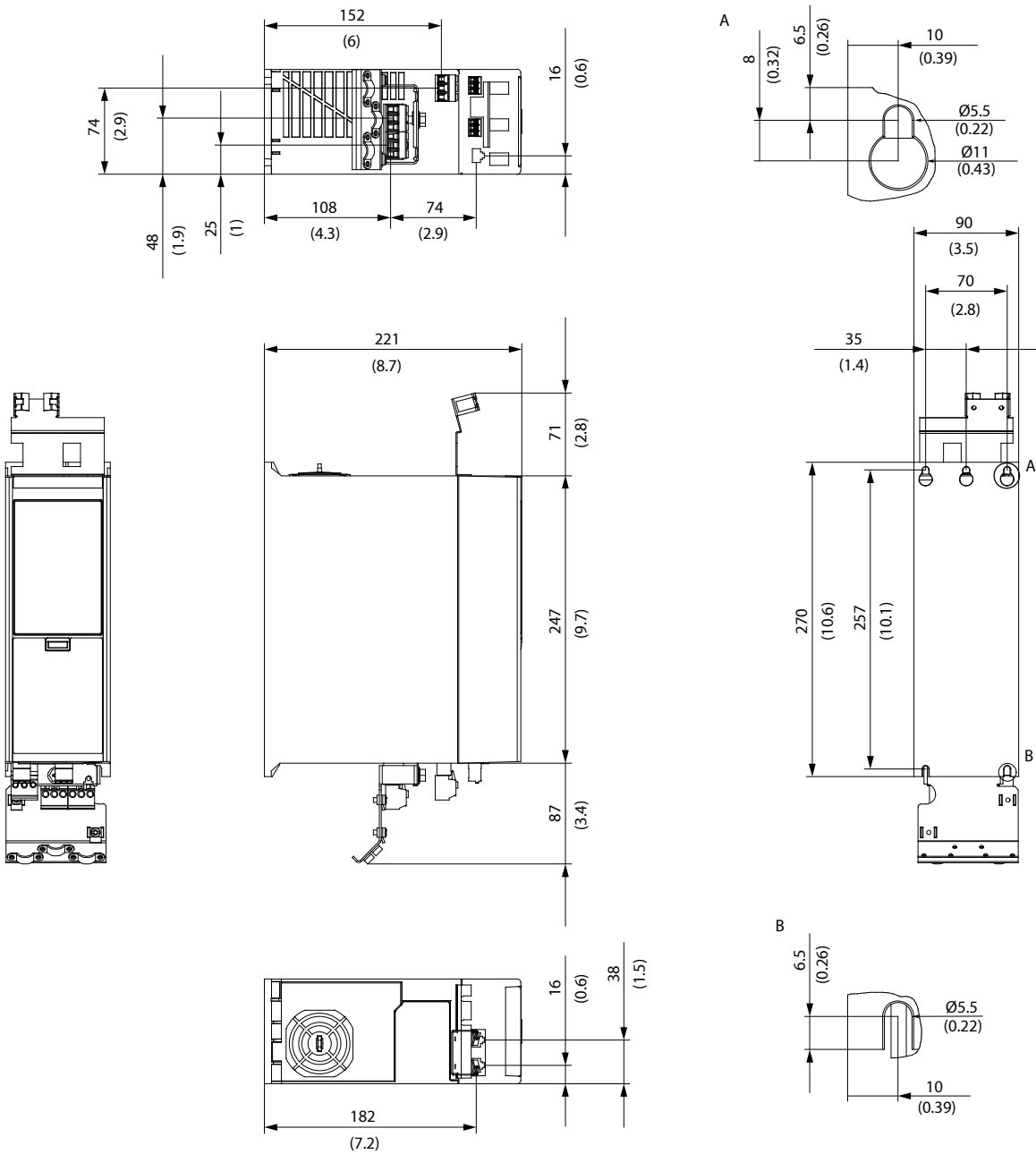

e30bi463.10

Figure 12: FA02a Dimensions

9.2.2 FA02b Dimensions

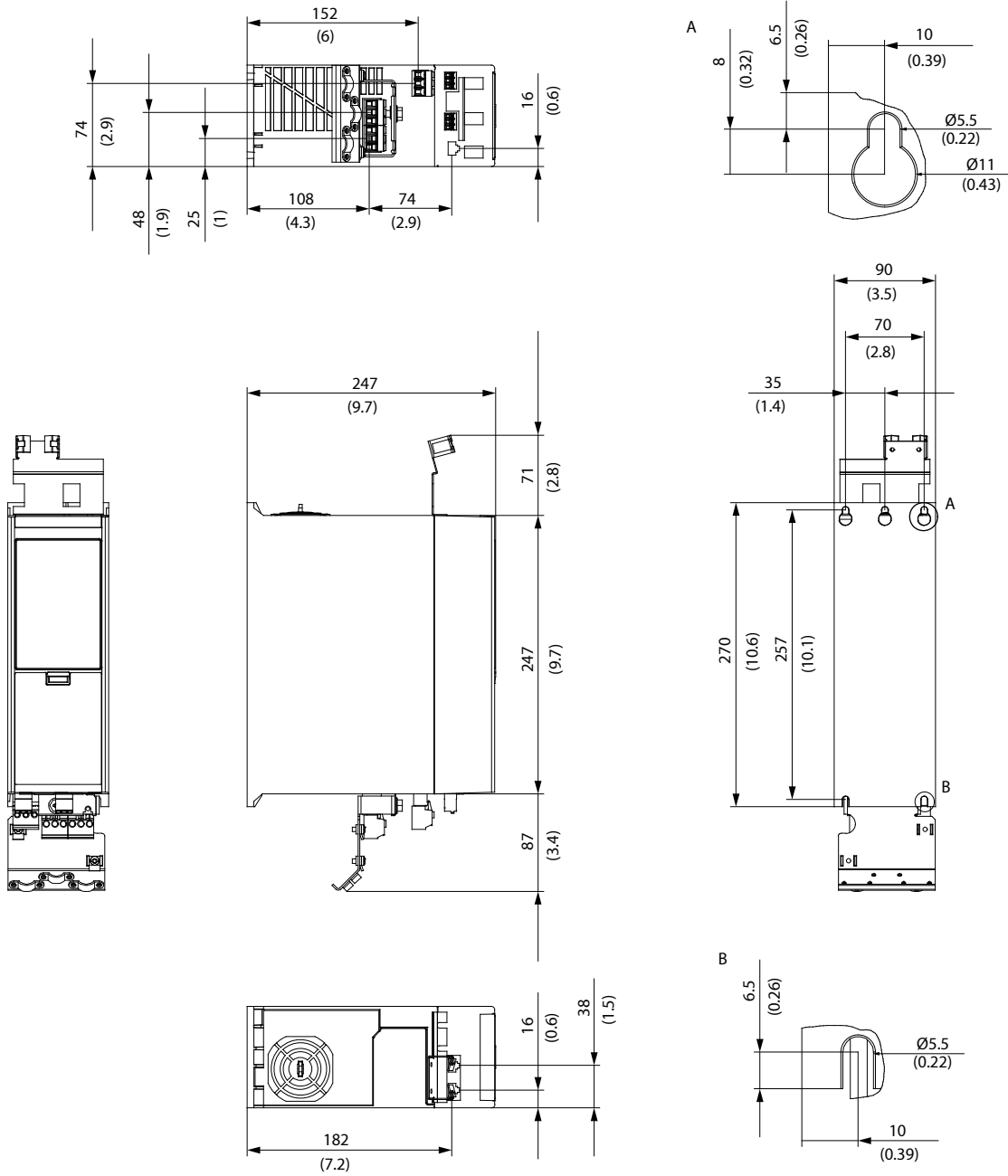

e30bi464.10

Figure 13: FA02b Dimensions

9.2.3 FA03a Dimensions

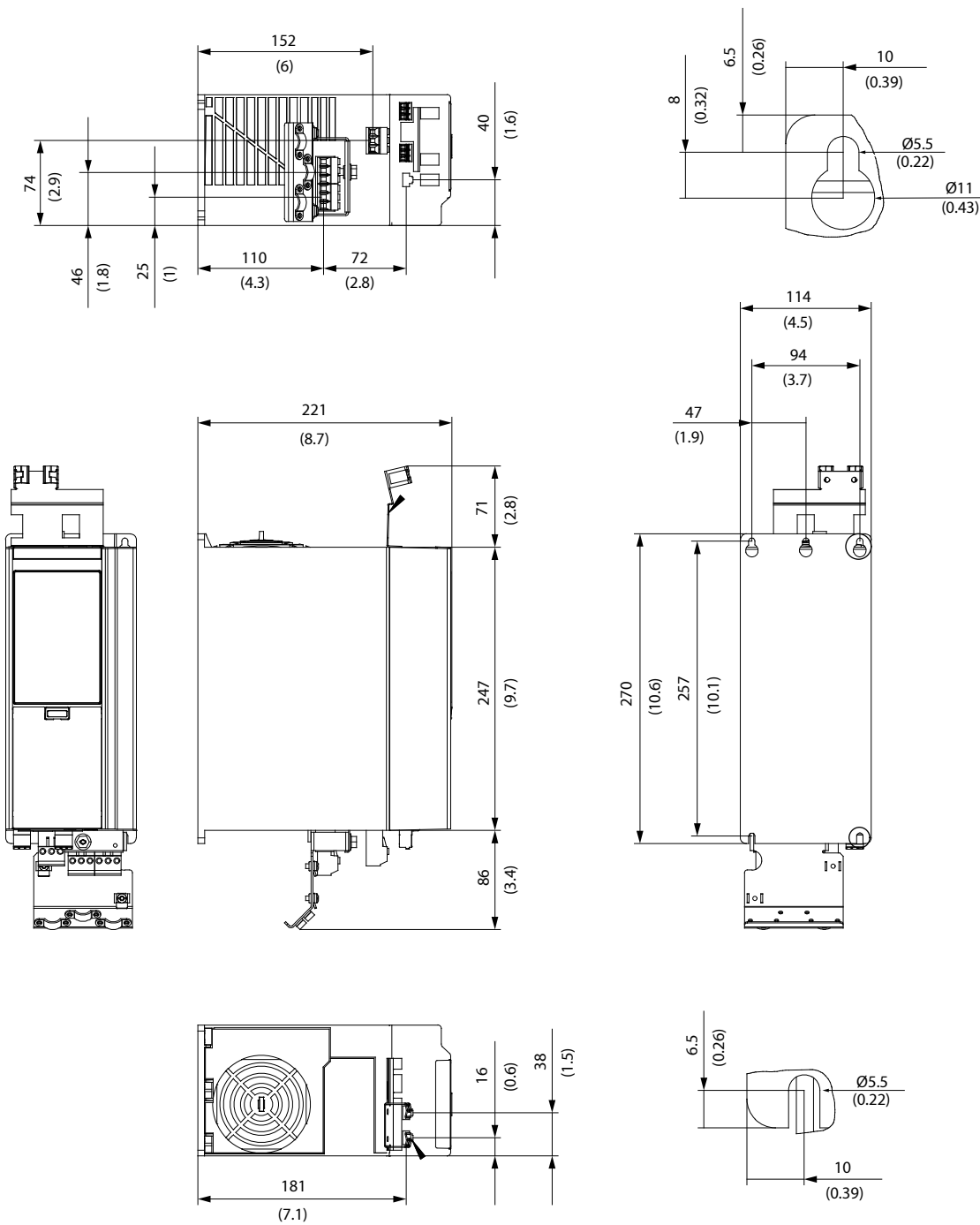

e30bi465.10

Figure 14: FA03a Dimensions

9.2.4 FA03b Dimensions

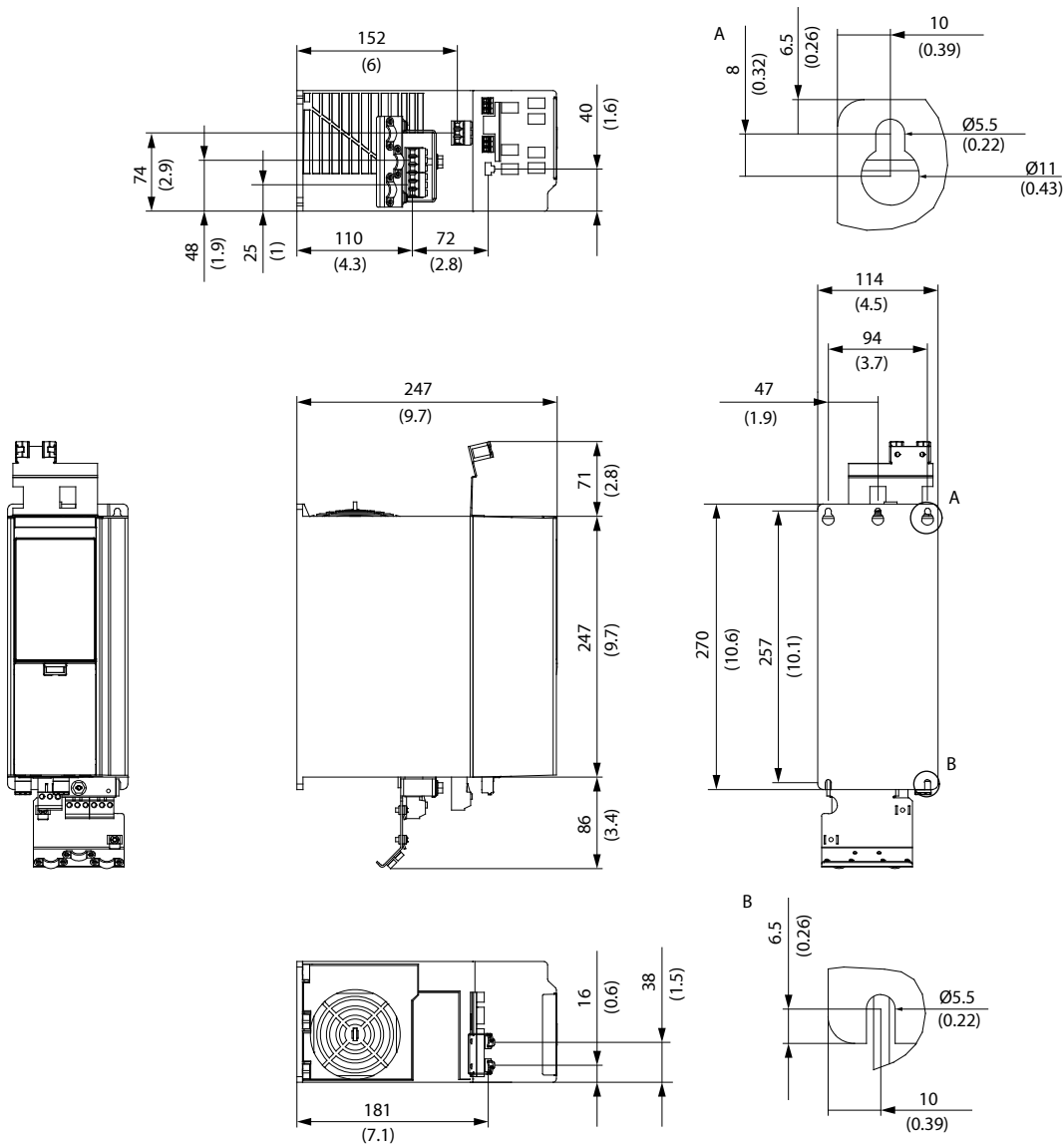

e30b/466.10

Figure 15: FA03b Dimensions



9.2.5 FA04a Dimensions

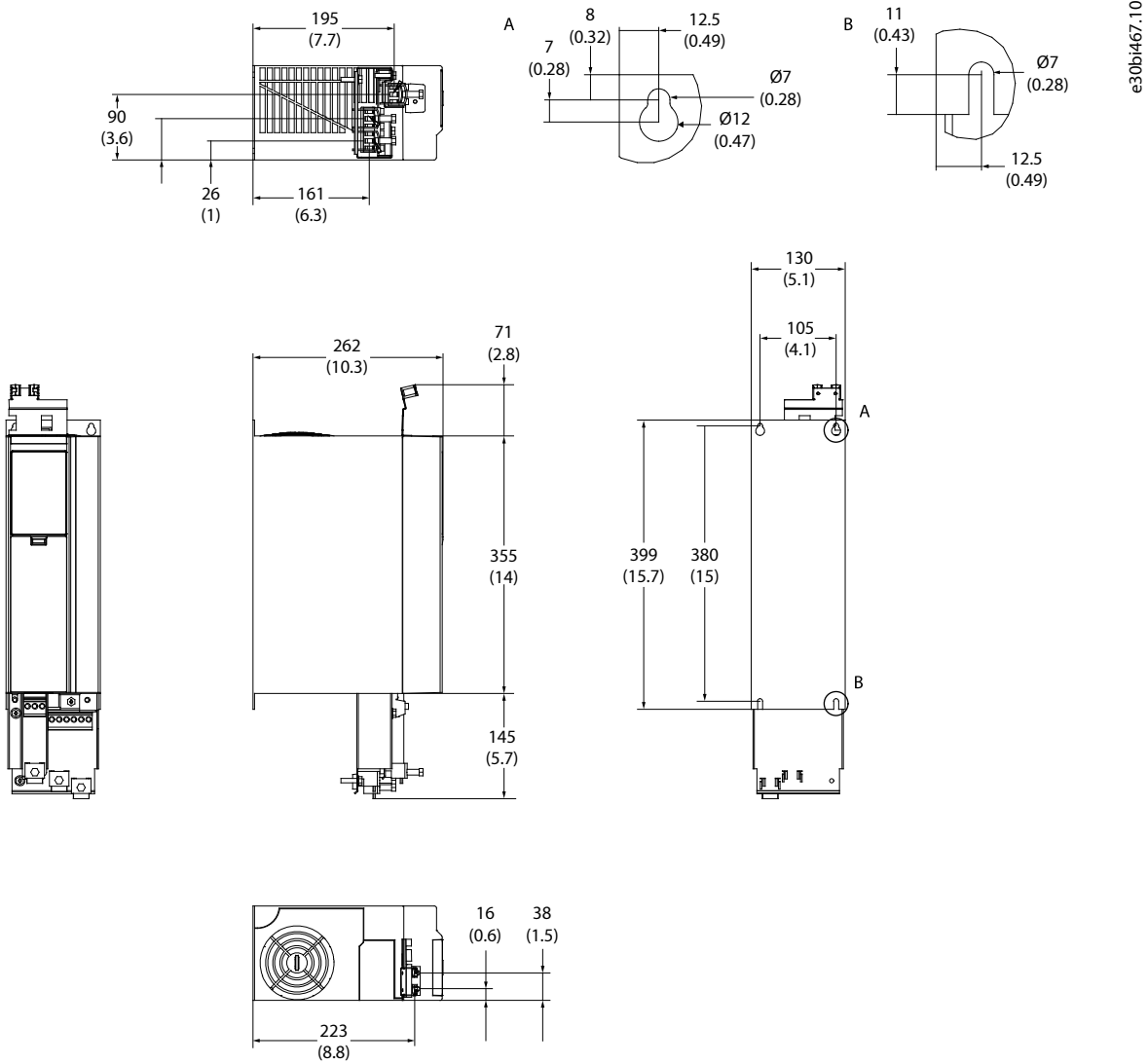
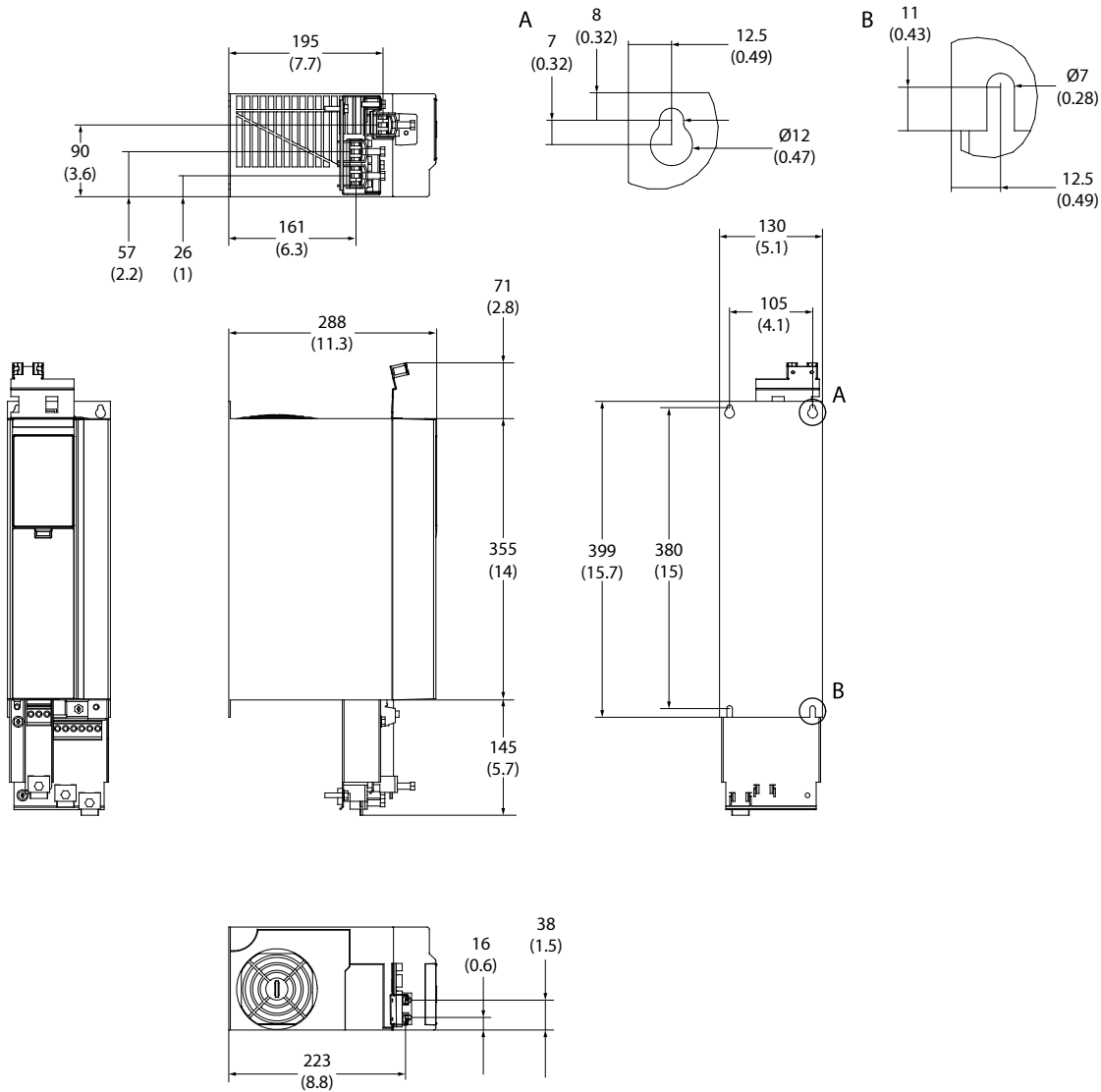

Figure 16: FA04a Dimensions

9.2.6 FA04b Dimensions



e30bi468.10

Figure 17: FA04b Dimensions

9.2.7 FA05a Dimensions

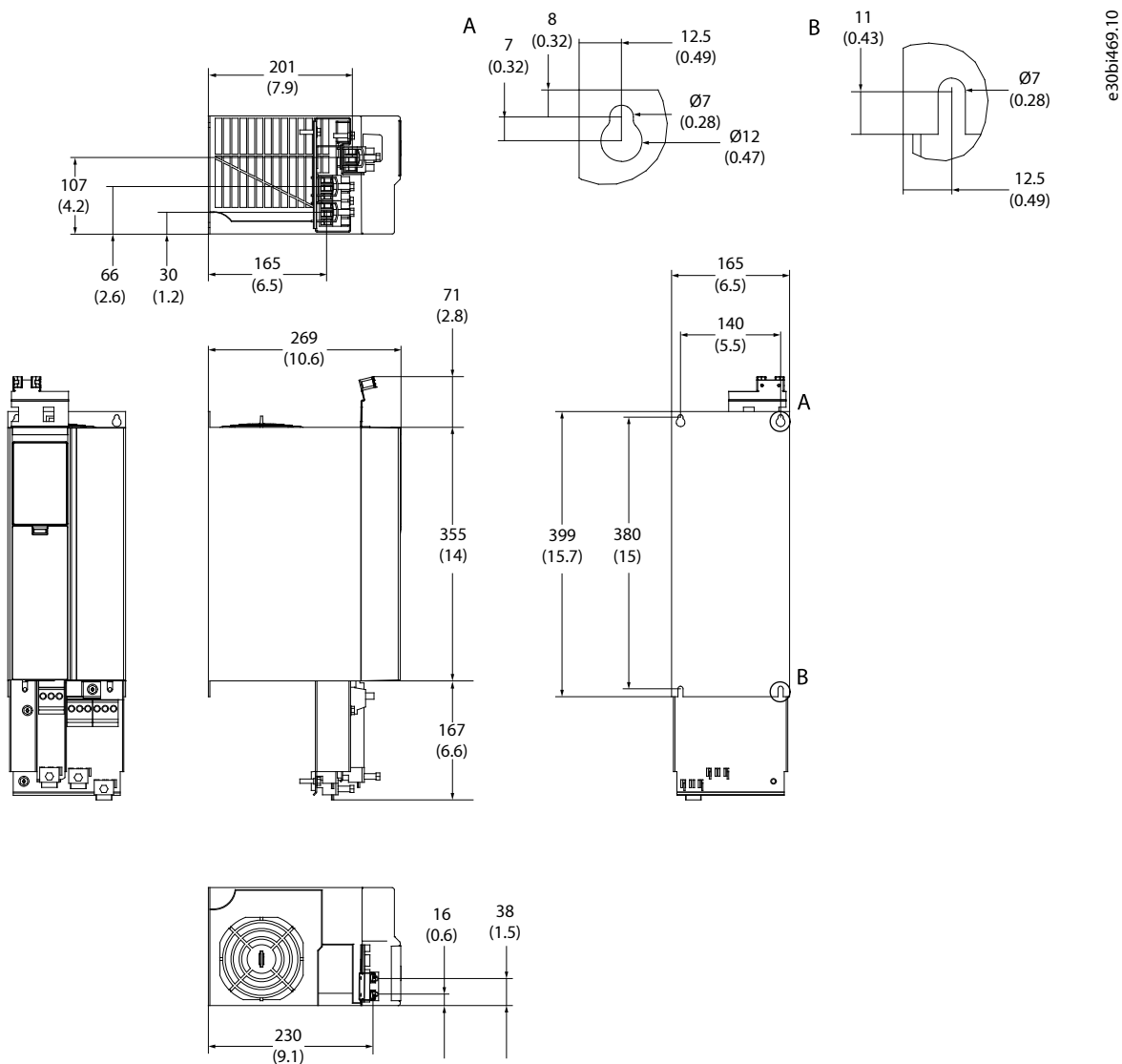

e30bi469.10

Figure 18: FA05a Dimensions

### 9.2.8 FA05b Dimensions

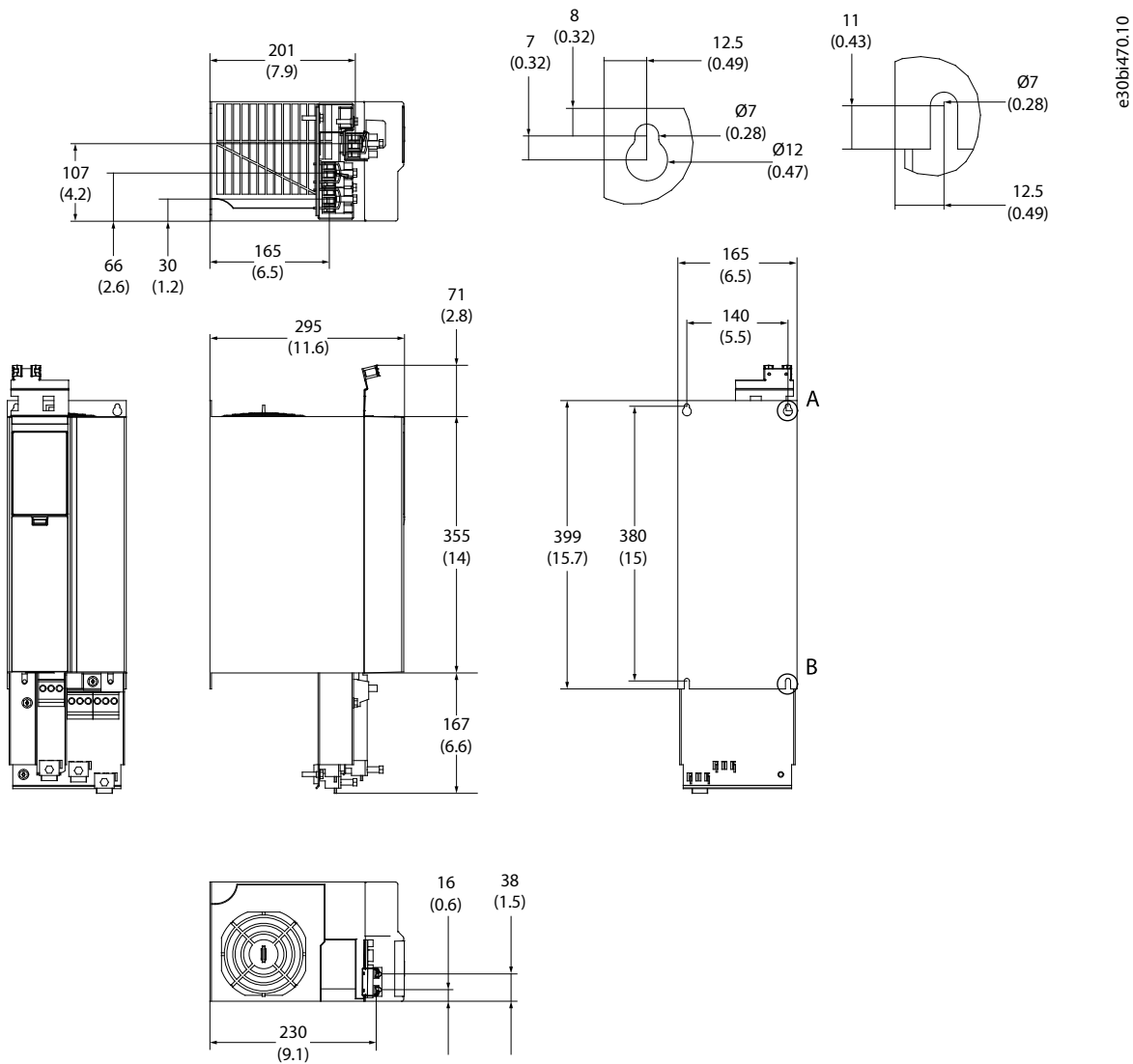

e30b1470.10

Figure 19: FA05b Dimensions

## 9.2.9 FA06 Dimensions

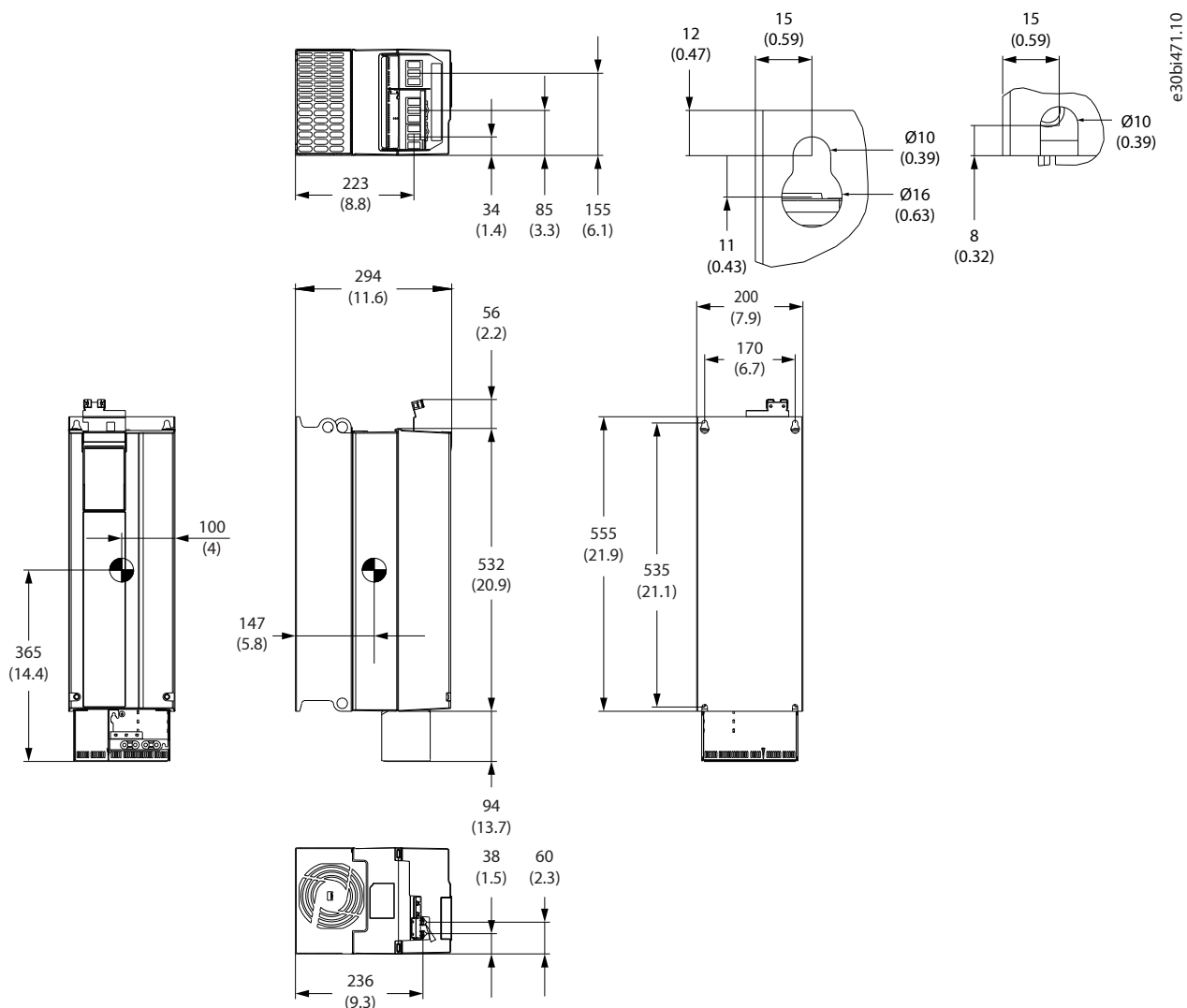

Figure 20: FA06 Dimensions

9.2.10 FA07 Dimensions

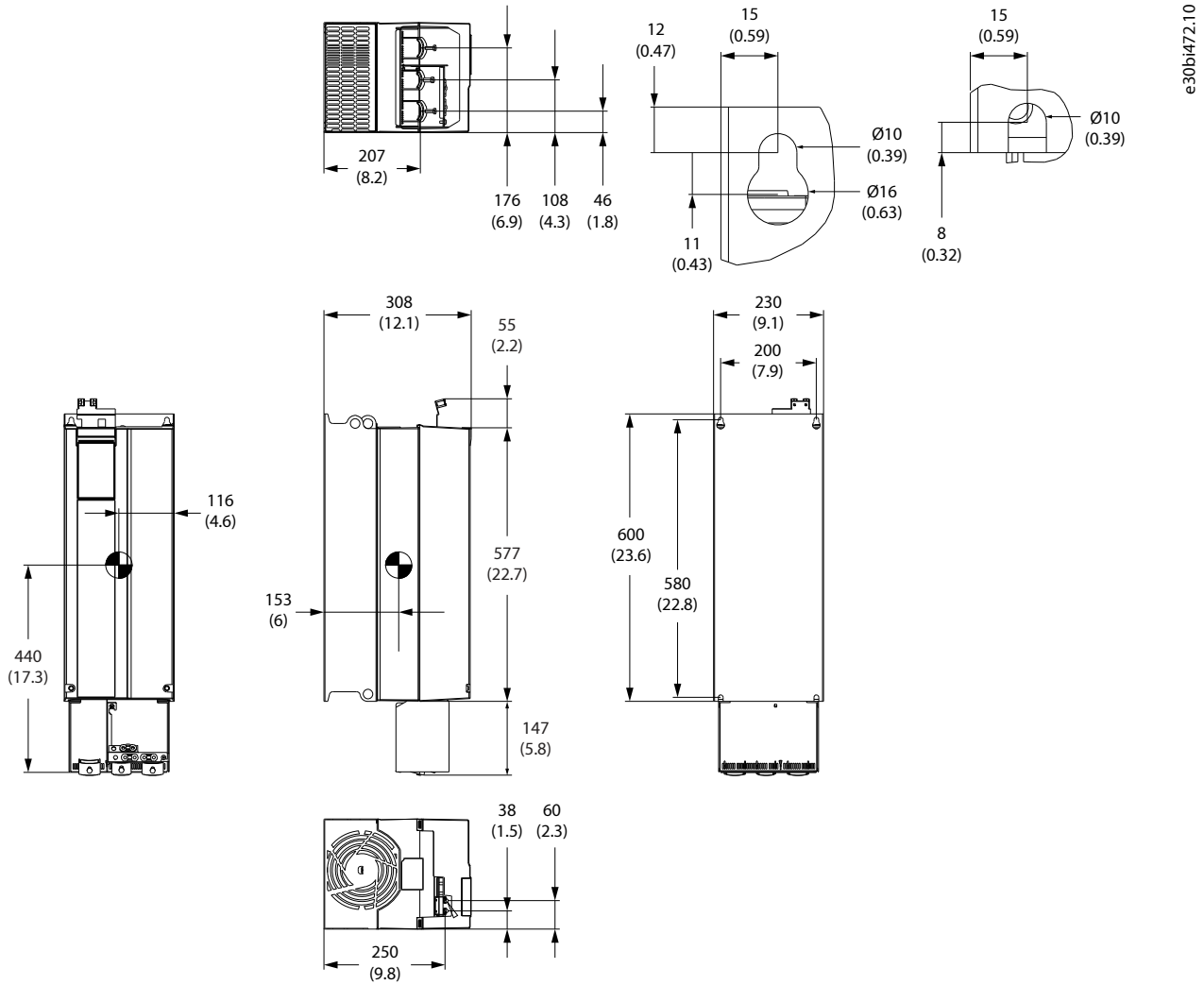

Figure 21: FA07 Dimensions

9.2.11 FA08 Dimensions

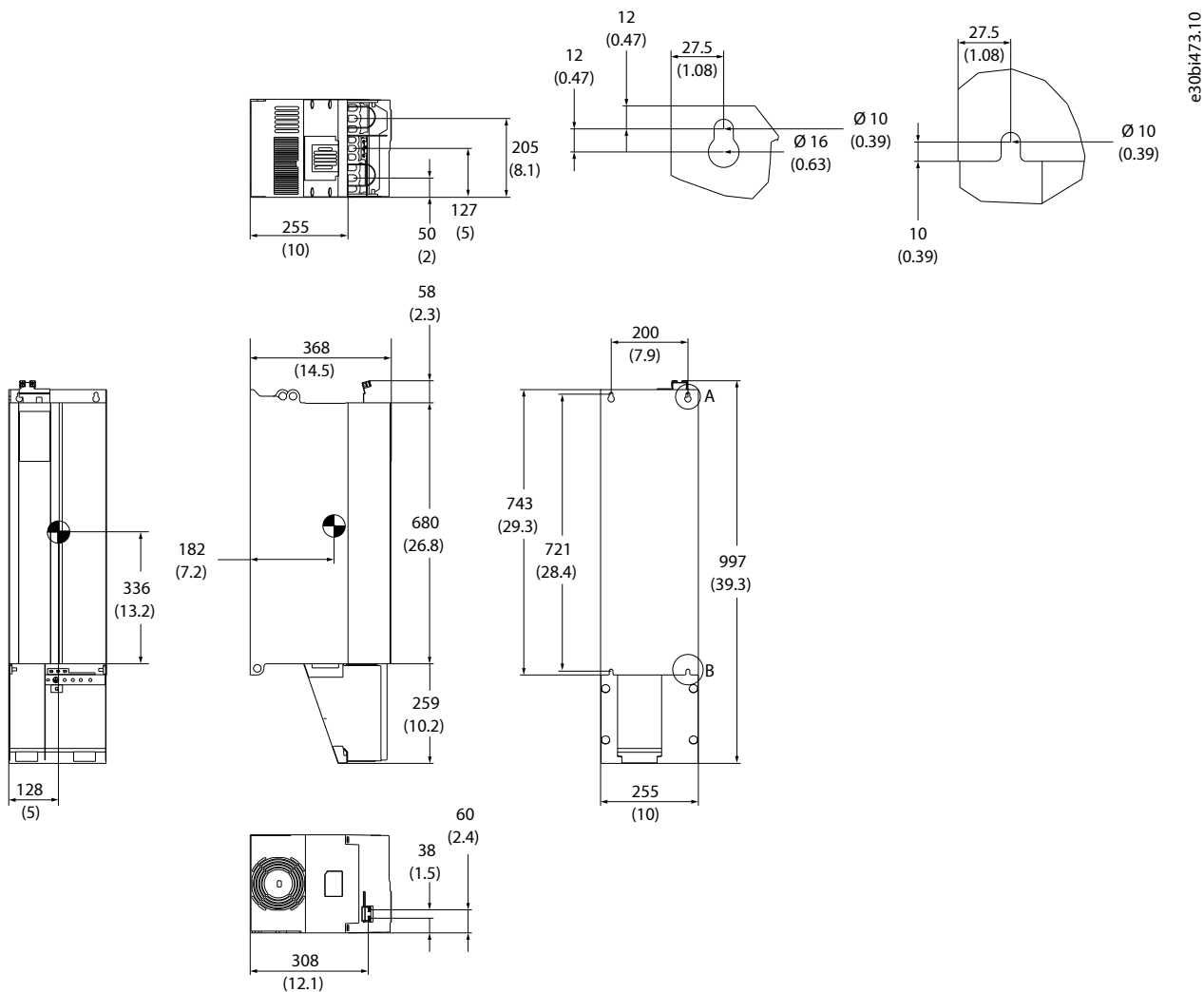
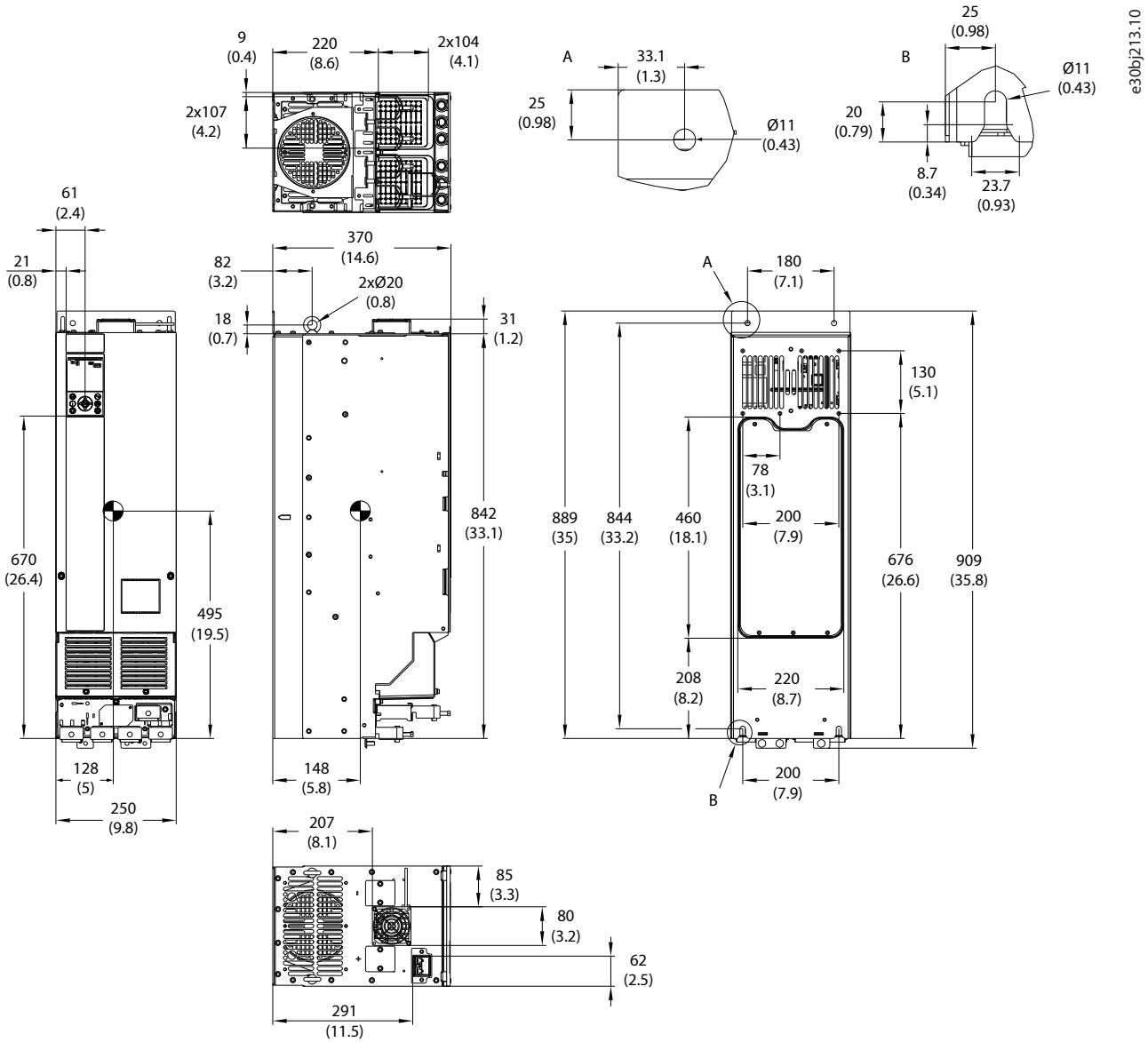

Figure 22: FA08 Dimensions

9.2.12 FA09 Dimensions



e30bj213.10

Figure 23: FA09 Exterior Dimensions



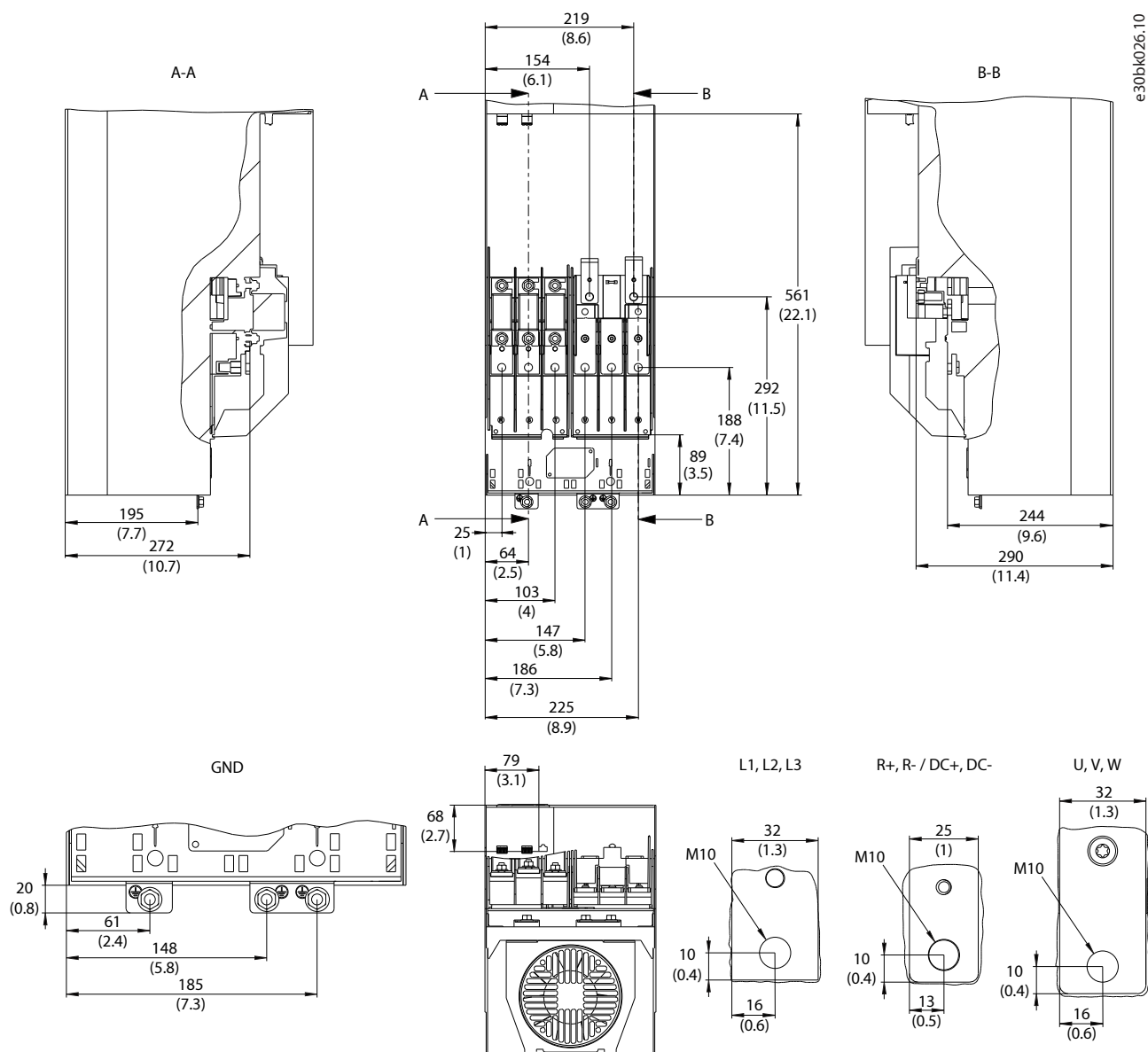

Figure 24: FA09 Terminal Dimensions

9.2.13 FA10 Dimensions

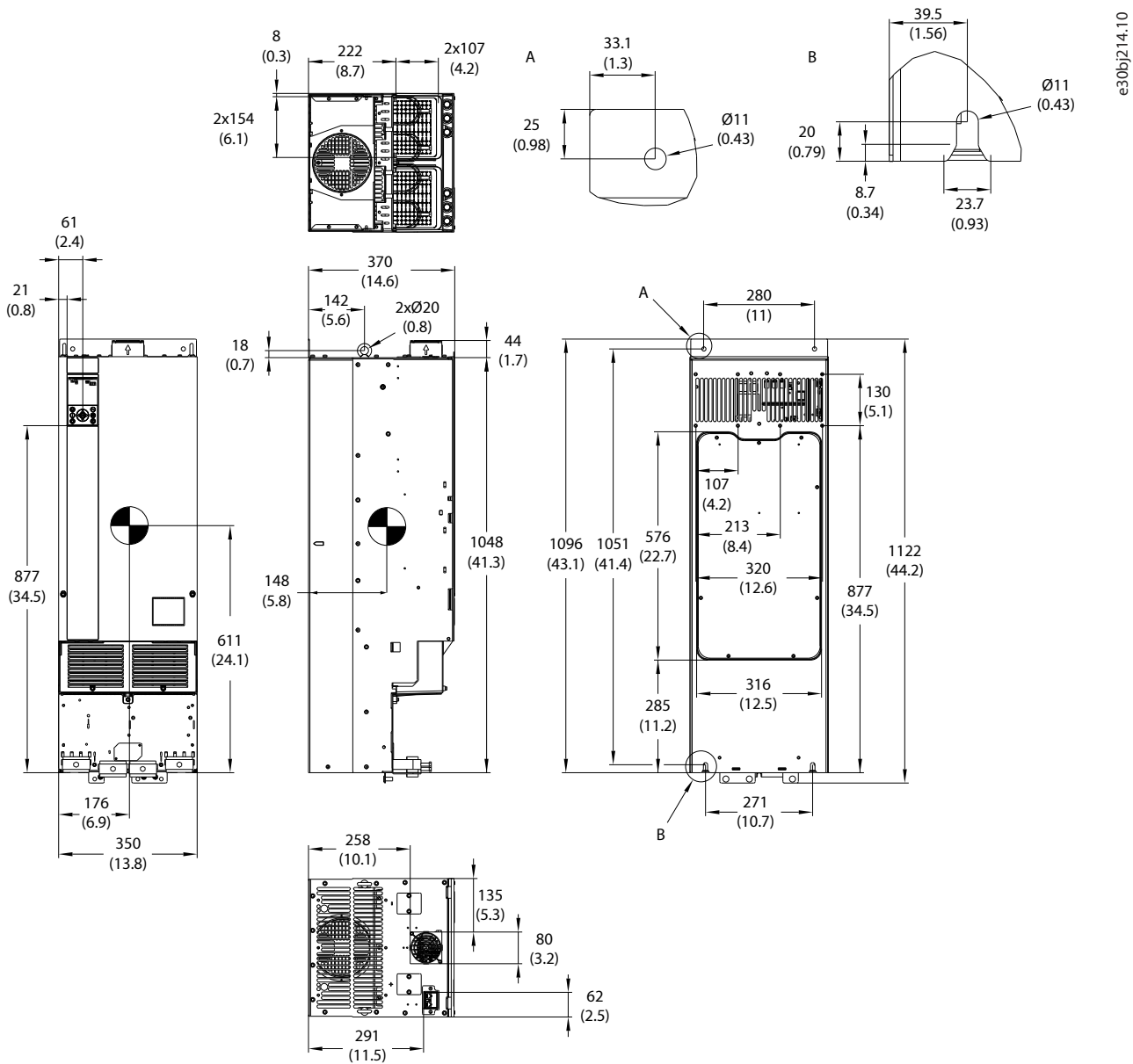

Figure 25: FA10 Exterior Dimensions

e30bk027.10

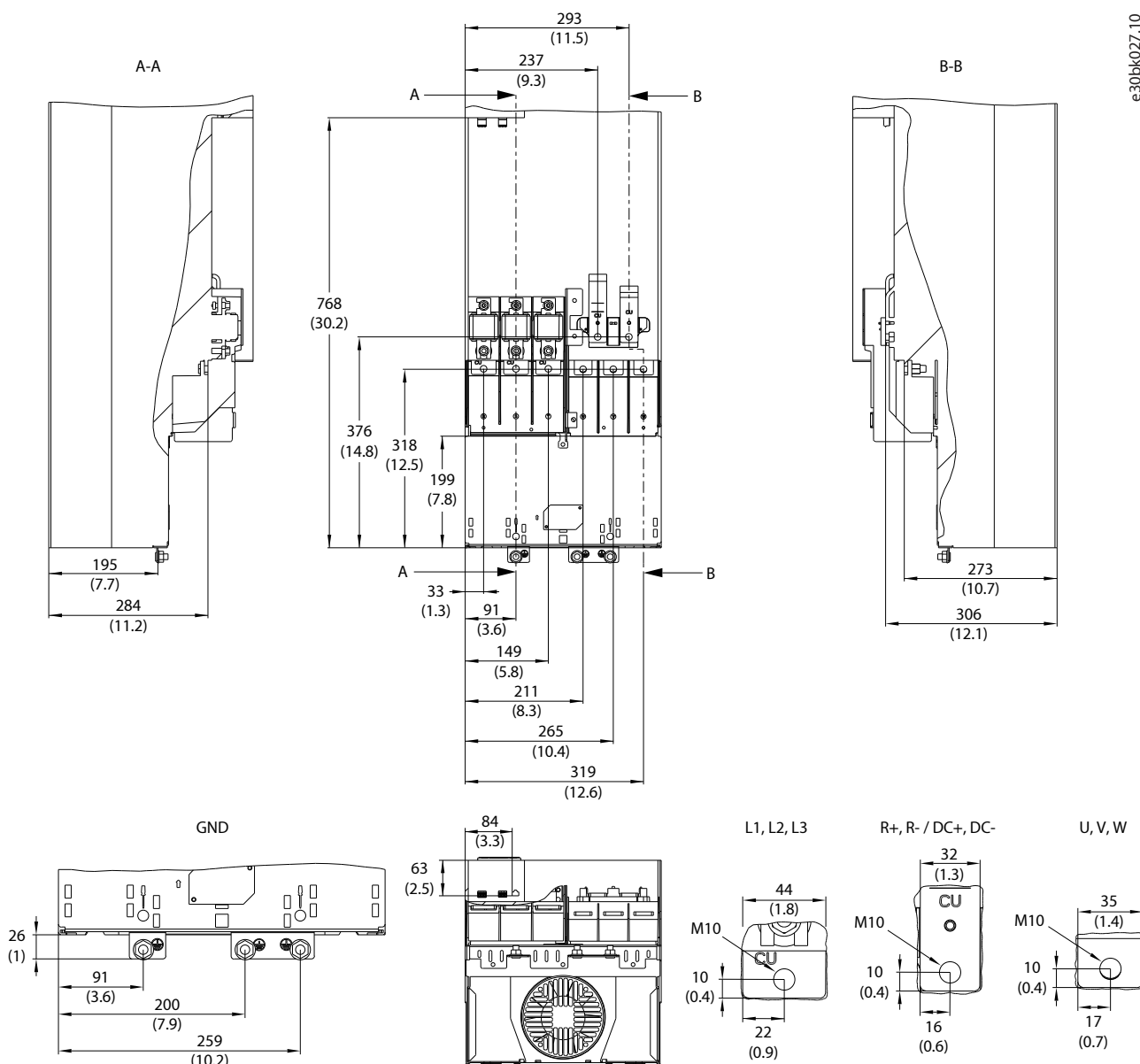

Figure 26: FA10 Terminal Dimensions

## 9.2.14 FA11 Dimensions

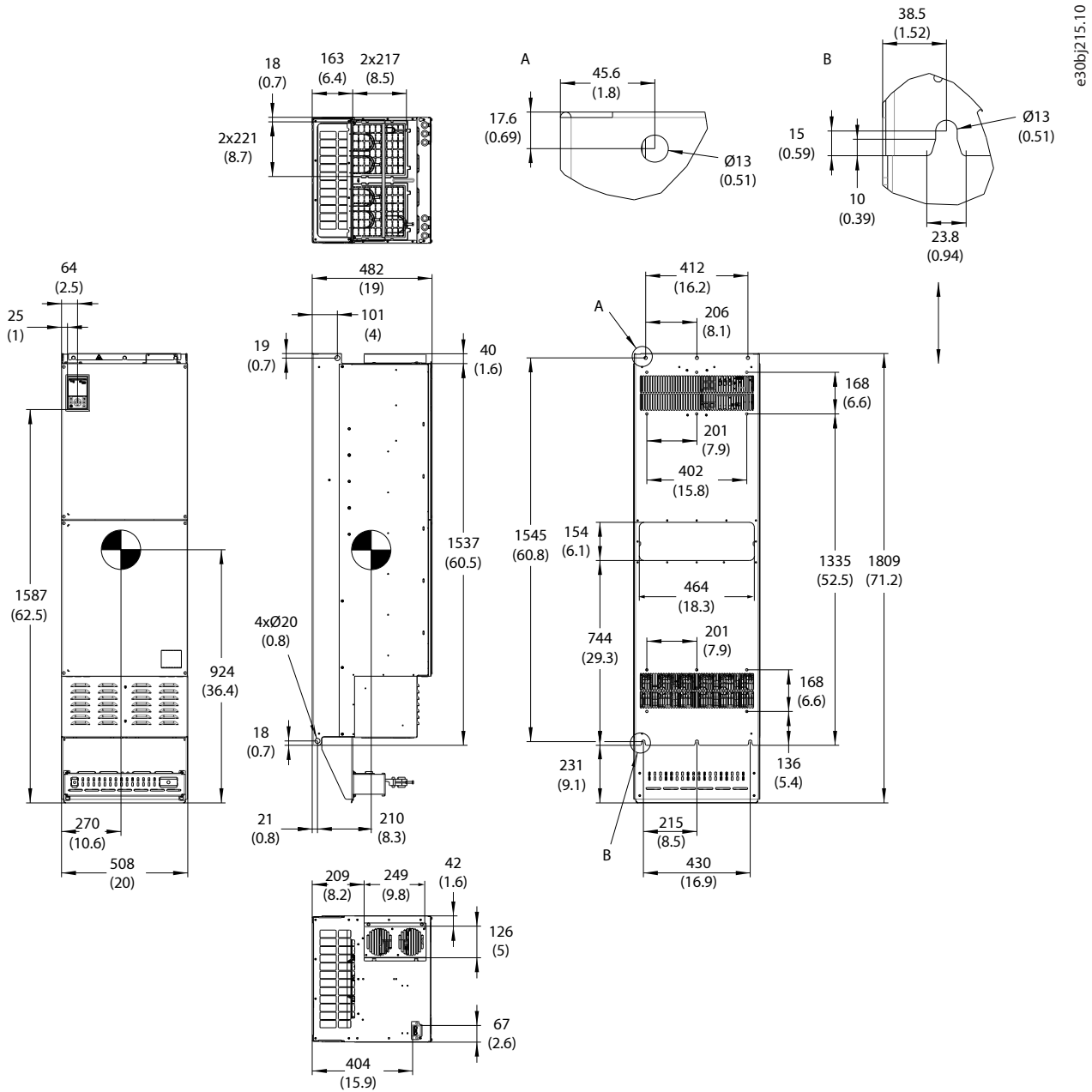
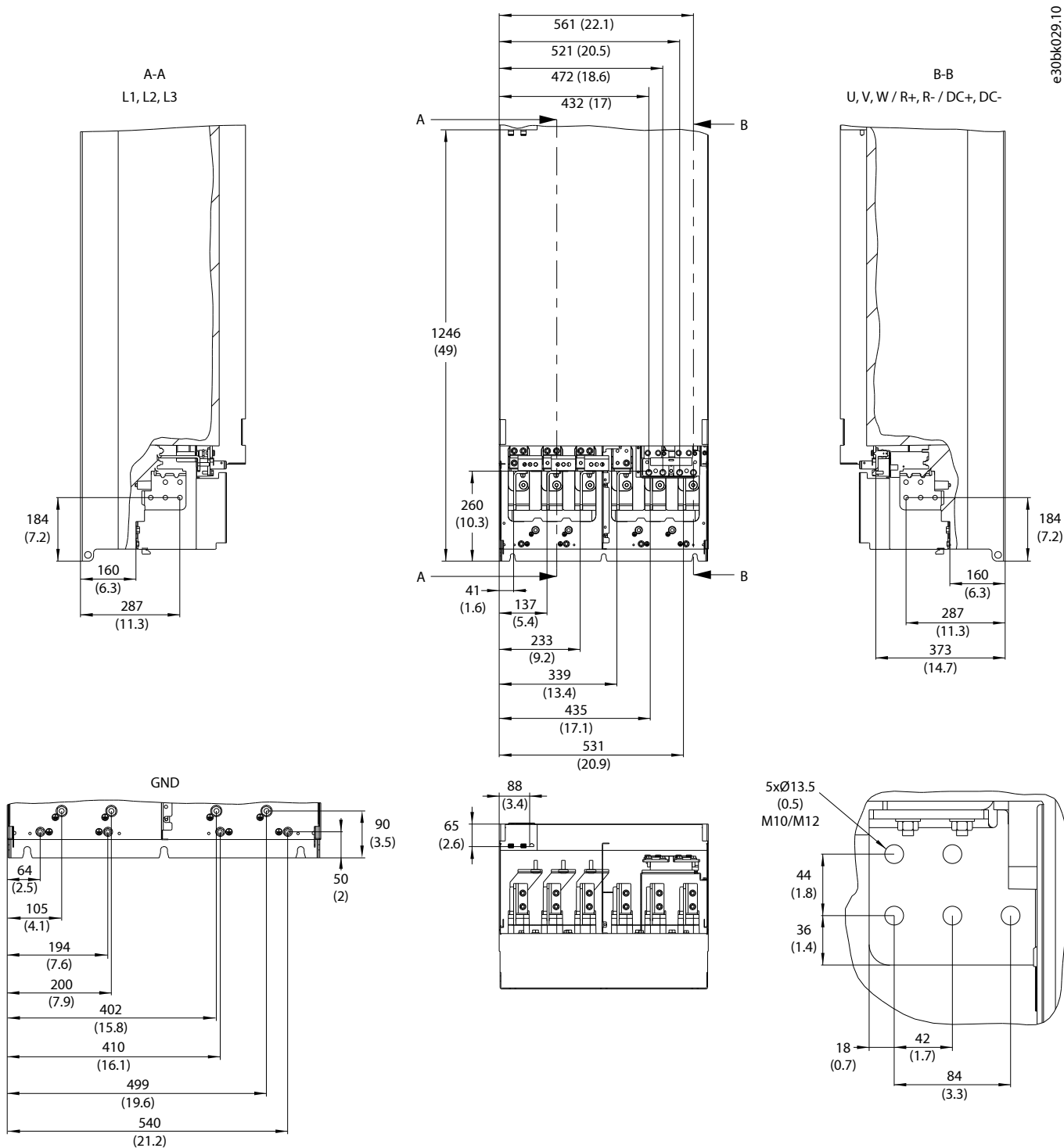
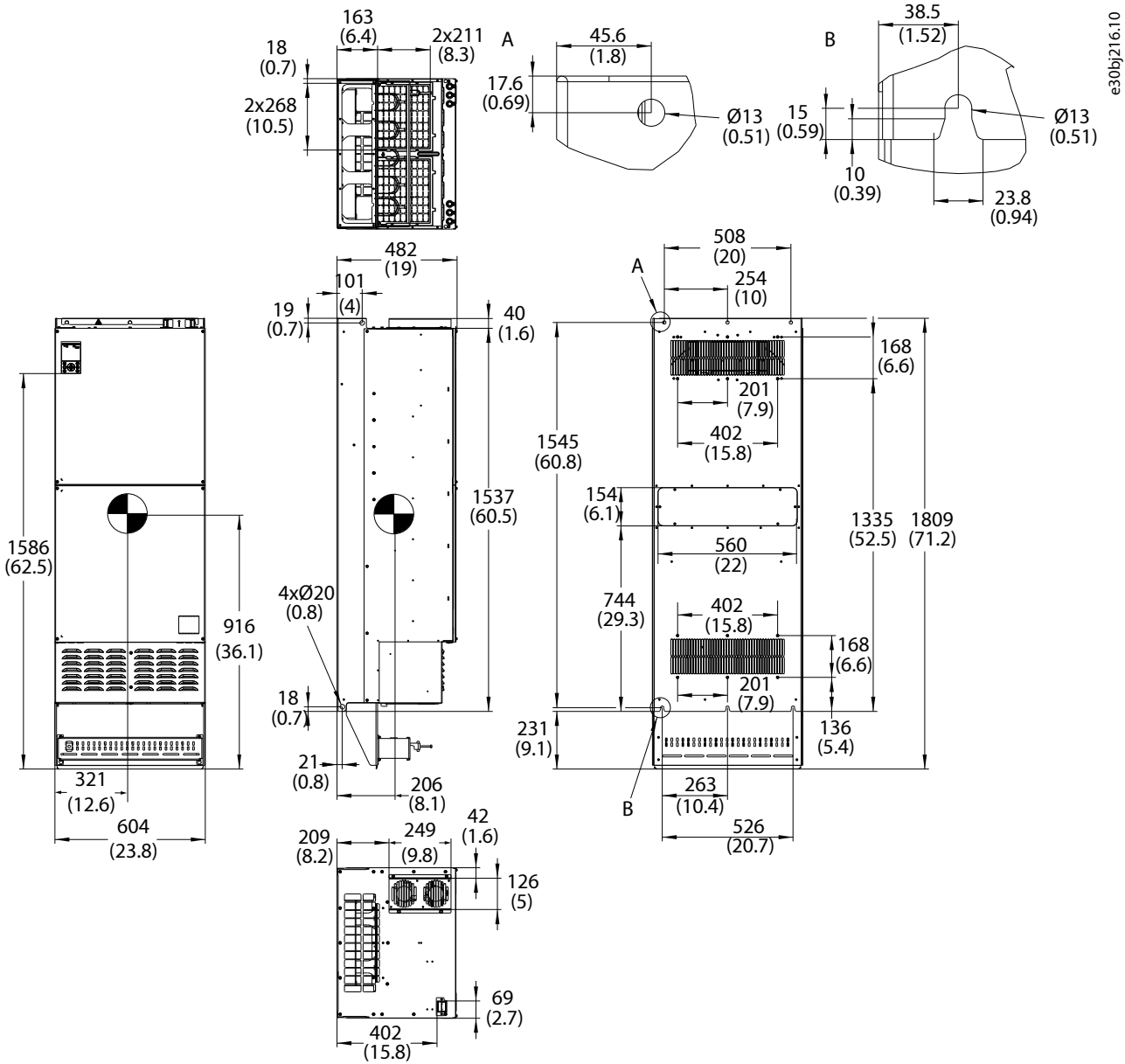

Figure 27: FA11 Exterior Dimensions



e30bk029.10

9.2.15 FA12 Dimensions



e30bj216.10

Figure 29: FA12 Exterior Dimensions

e30bk029.10

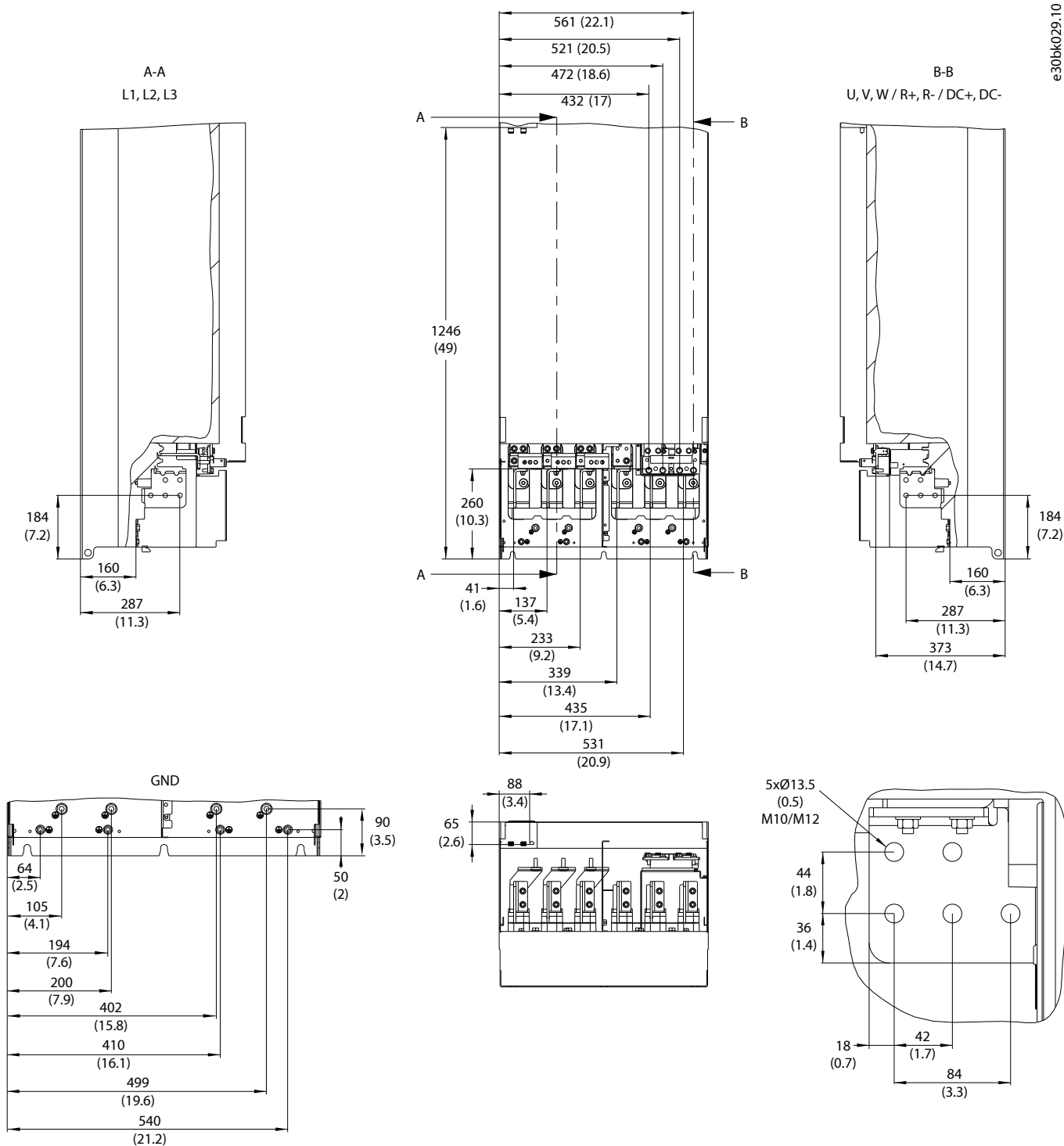
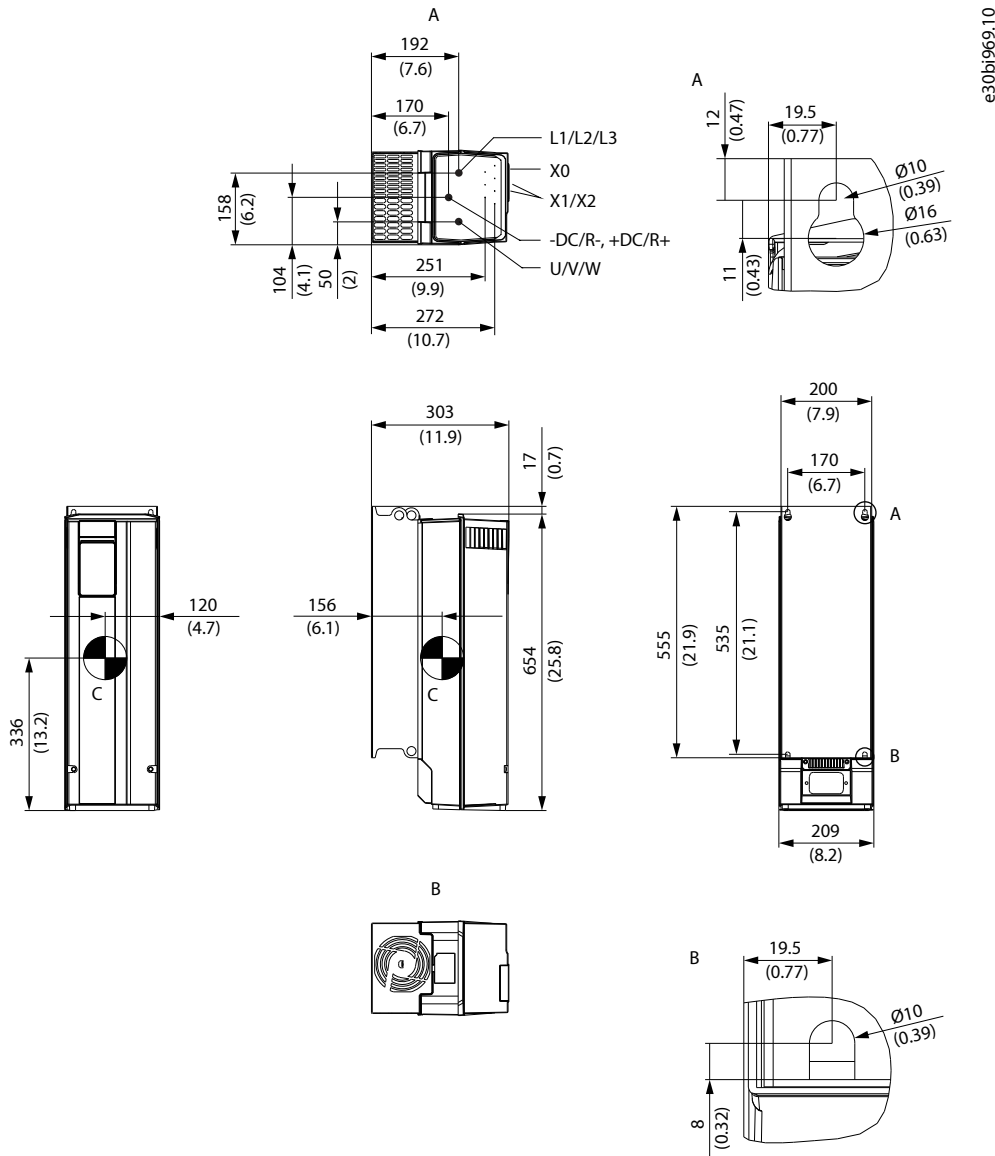

Figure 30: FA12 Terminal Dimensions

### 9.3 IP21/UL Type 1 Frames (FK06–FK12)

#### 9.3.1 FK06 Dimensions



e30b969.10

Figure 31: FK06 Dimensions



9.3.2 FK07 Dimensions

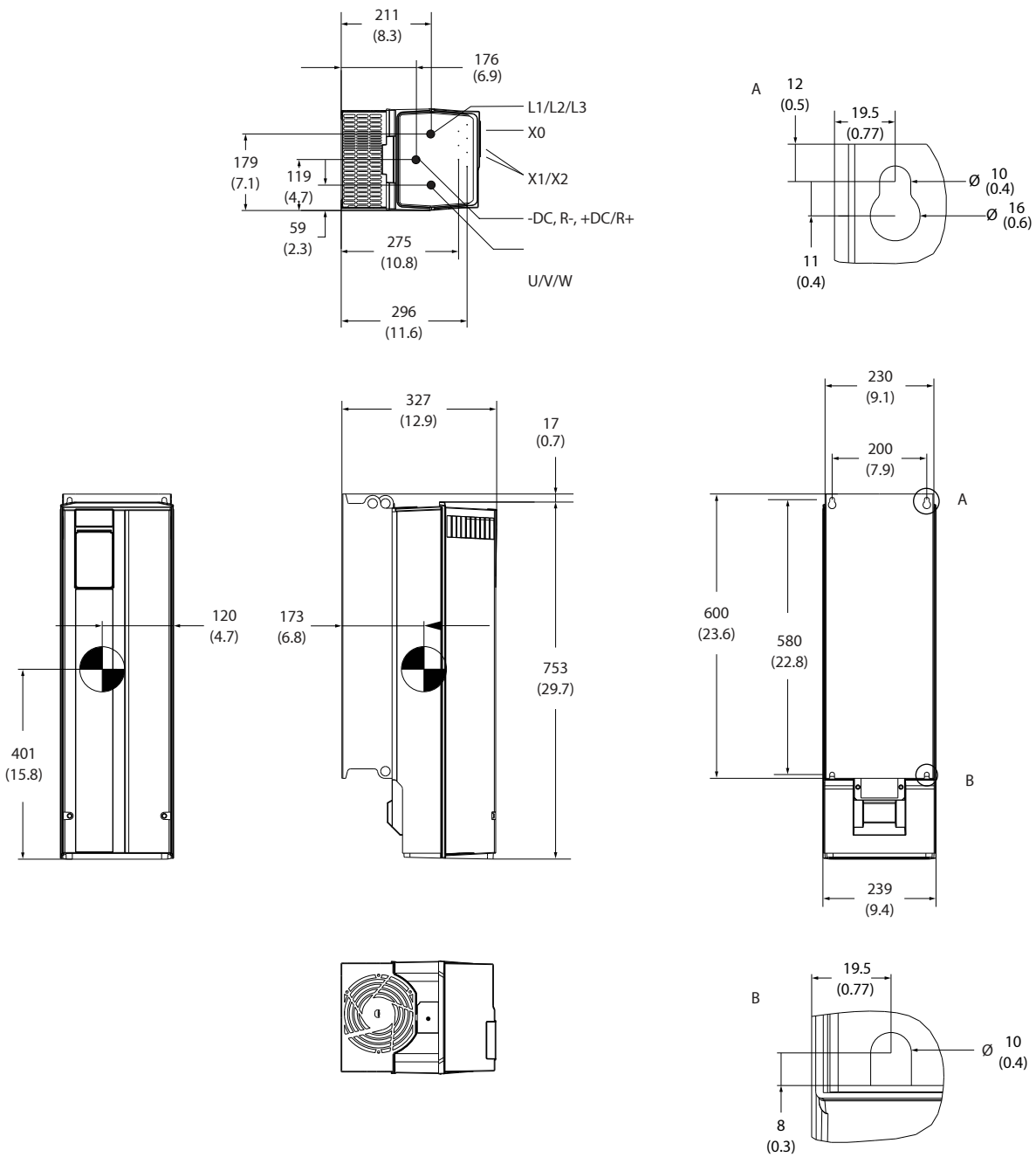

e30bi970.10

Figure 32: FK07 Dimensions

### 9.3.3 FK08 Dimensions

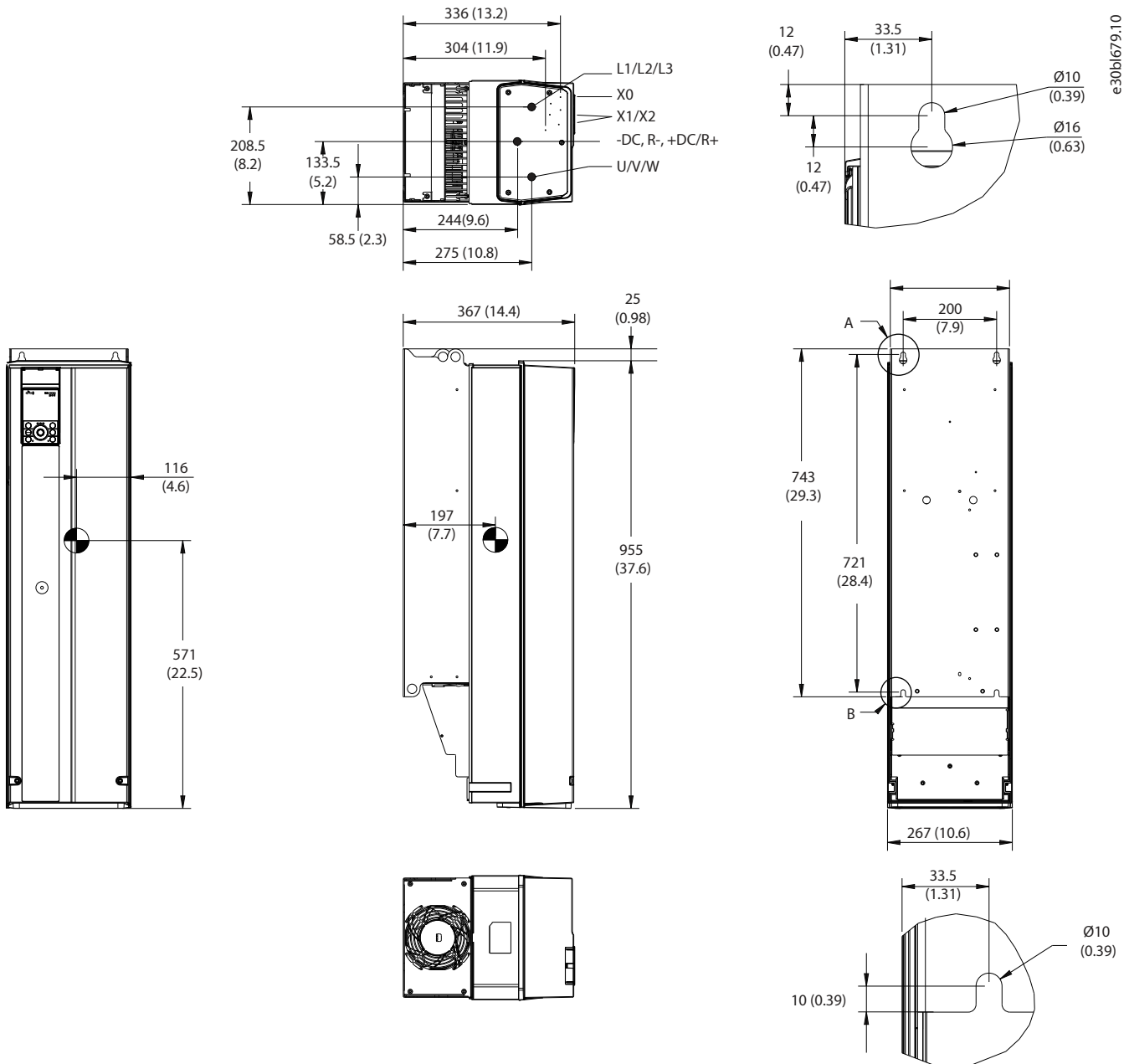

Figure 33: FK08 Dimensions

### 9.3.4 FK09a Dimensions

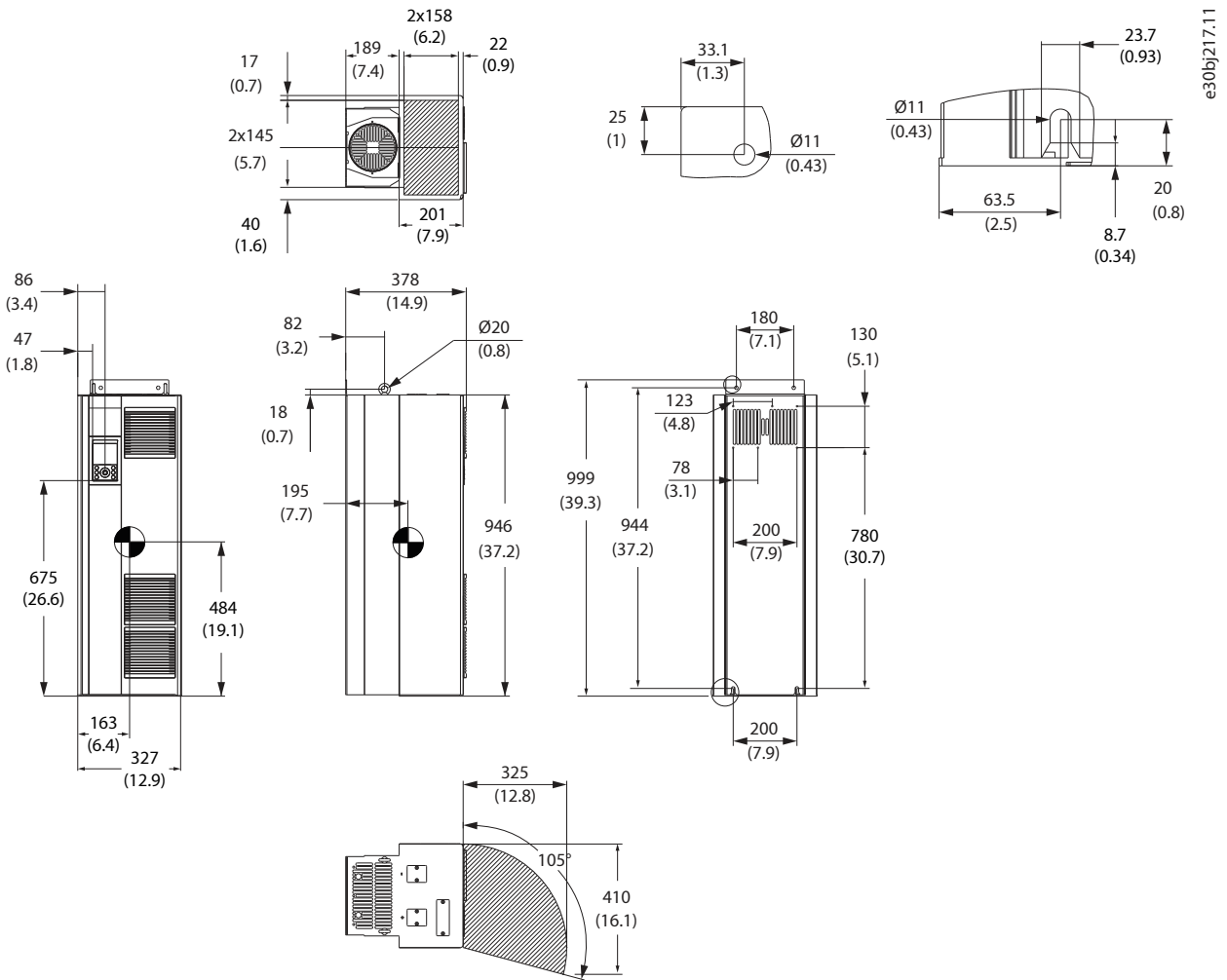

Figure 34: FK09a Dimensions

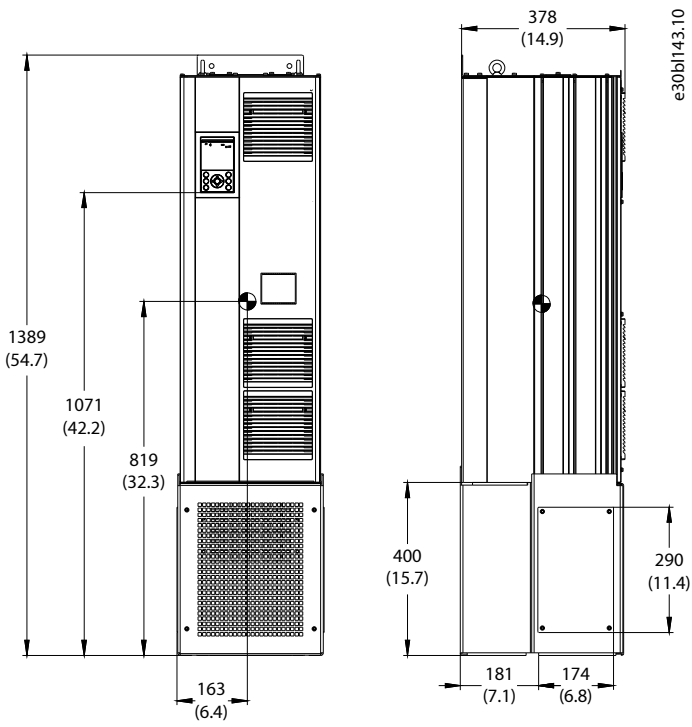

Figure 35: FK09a Dimensions with Optional Pedestal

9.3.5 FK09c Dimensions

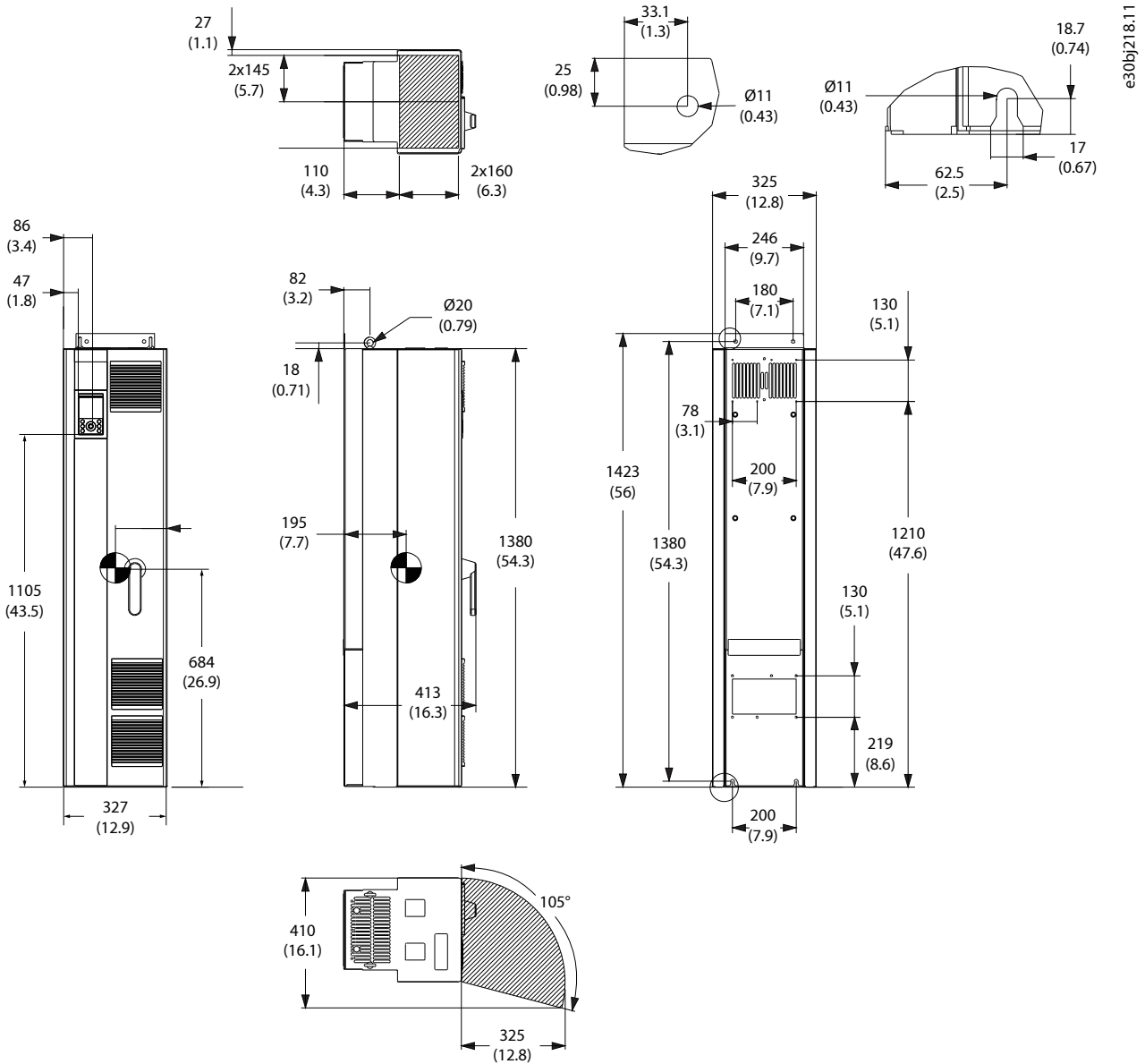

Figure 36: FK09c Dimensions

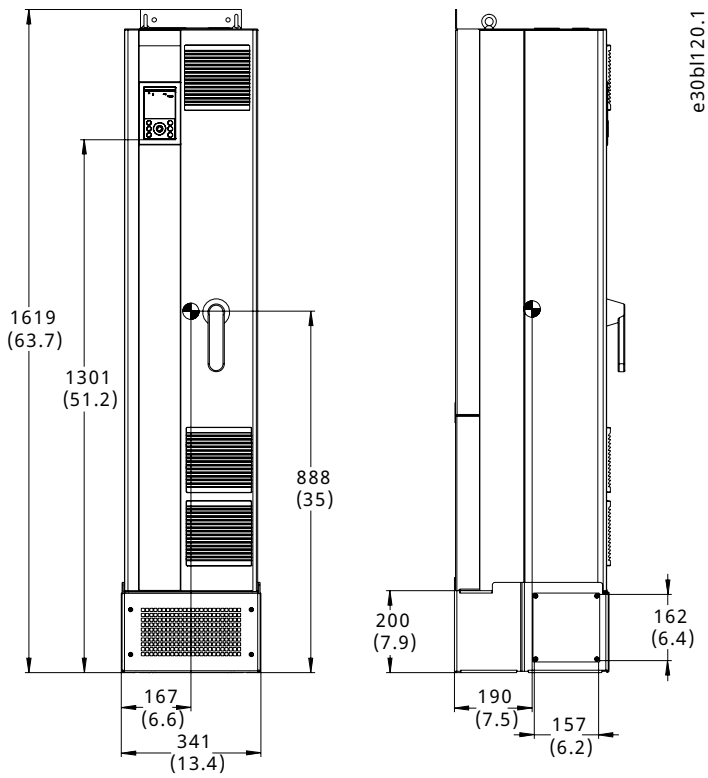

Figure 37: FK09c Dimensions with Optional Pedestal

## 9.3.6 FK10a Dimensions

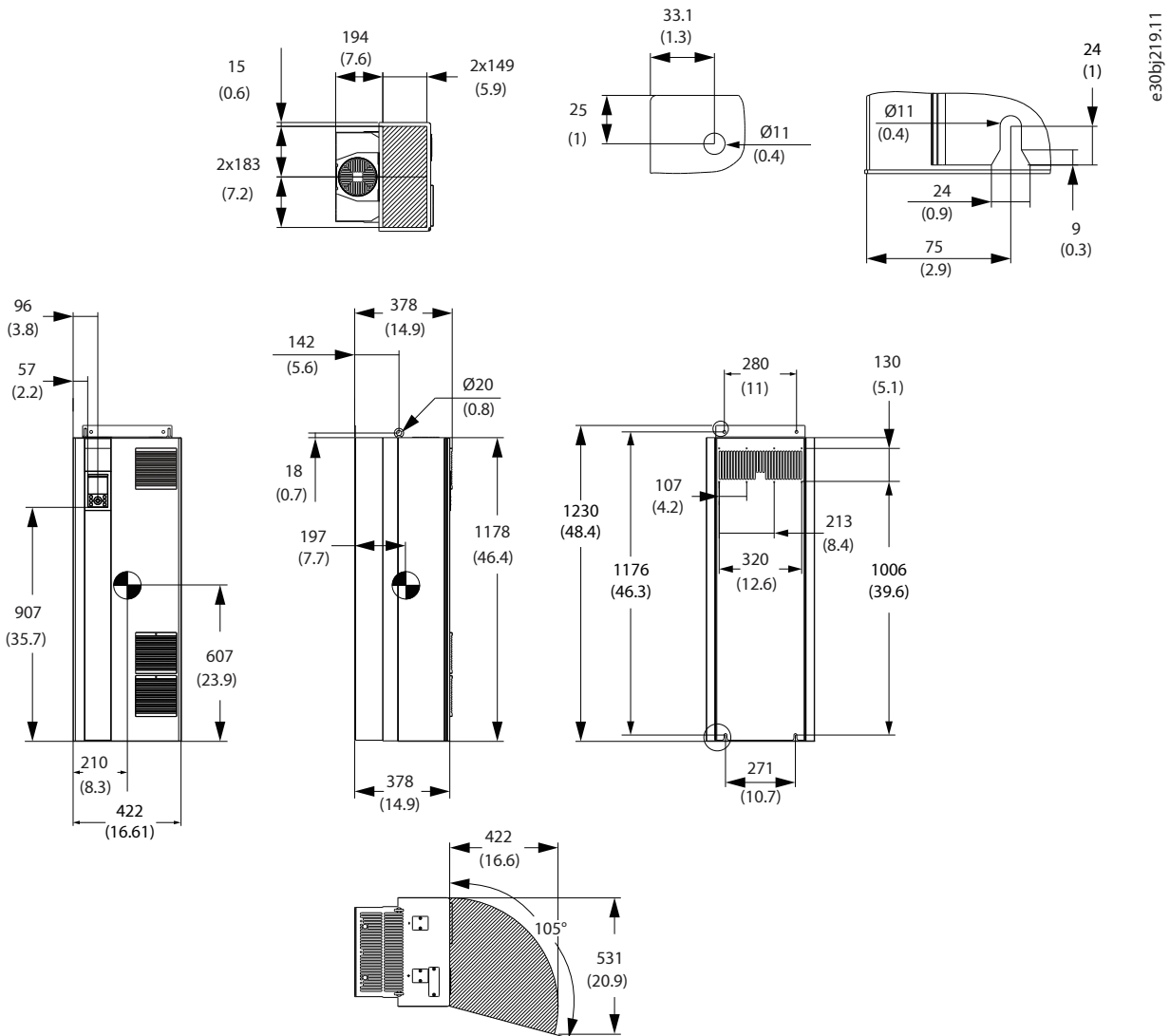

Figure 38: FK10a Dimensions

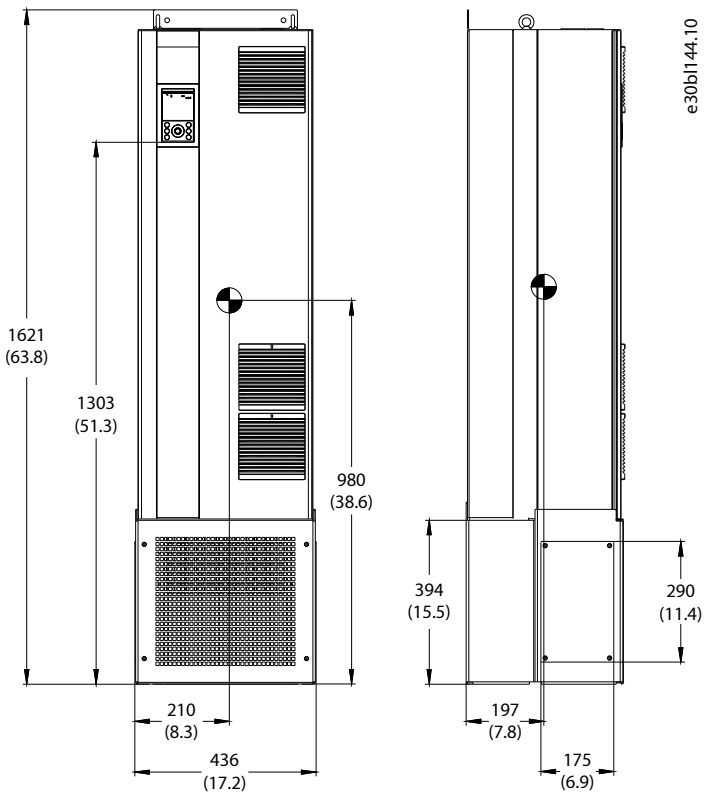
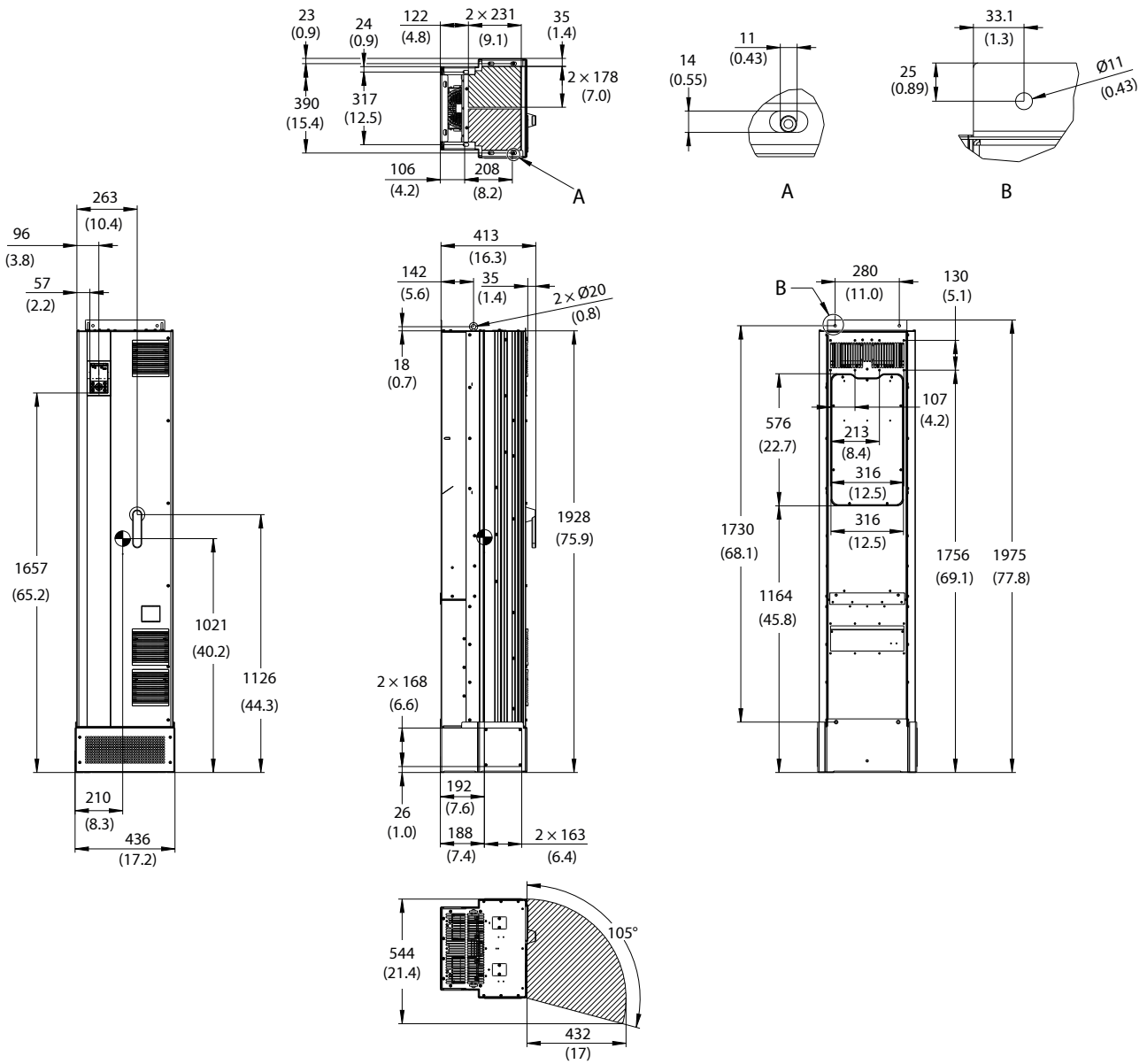

Figure 39: FK10a Dimensions with Optional Pedestal



9.3.7 FK10c Dimensions



e30bj220.12

Figure 40: FK10c Dimensions

9.3.8 FK11 Dimensions

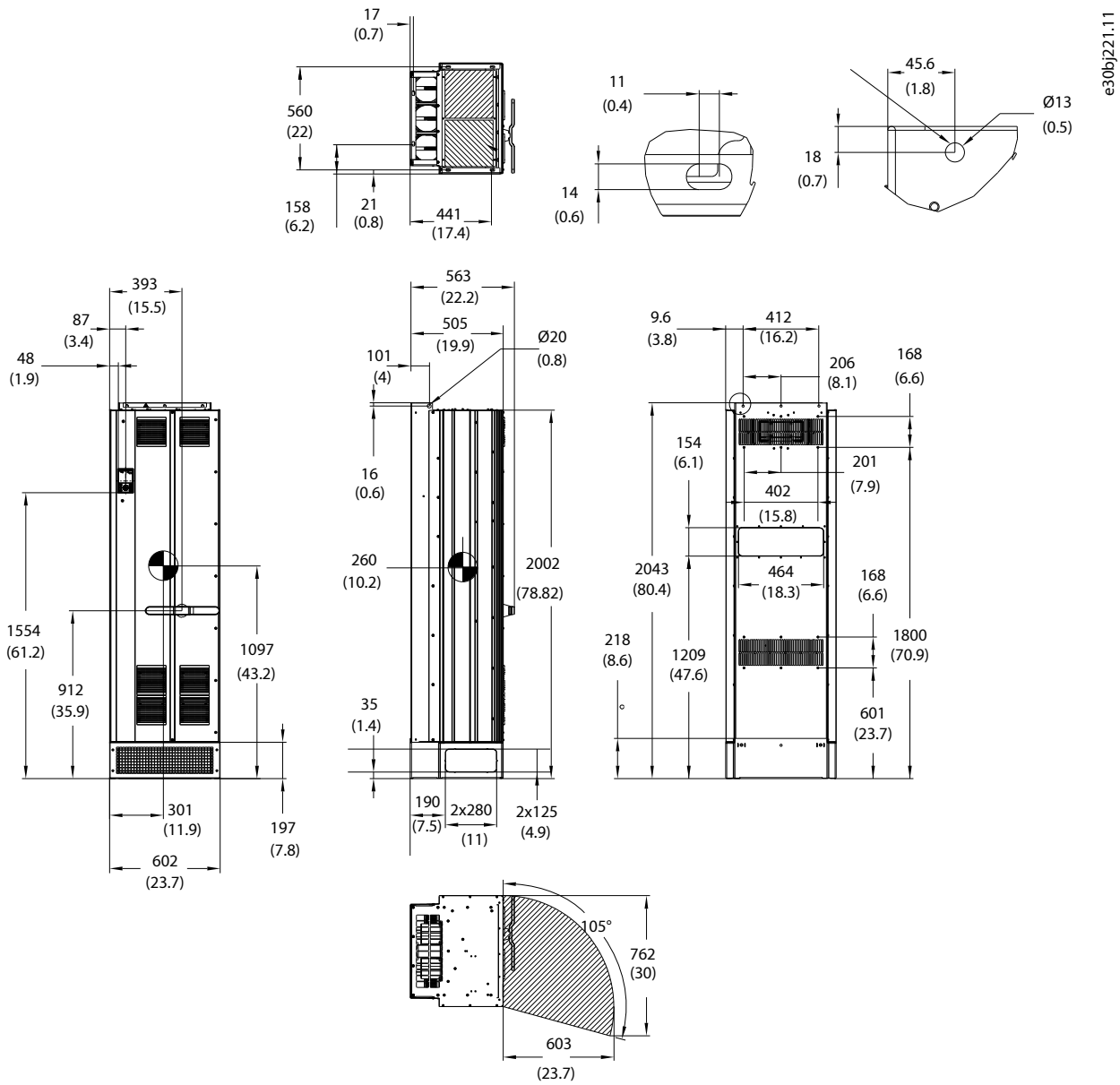
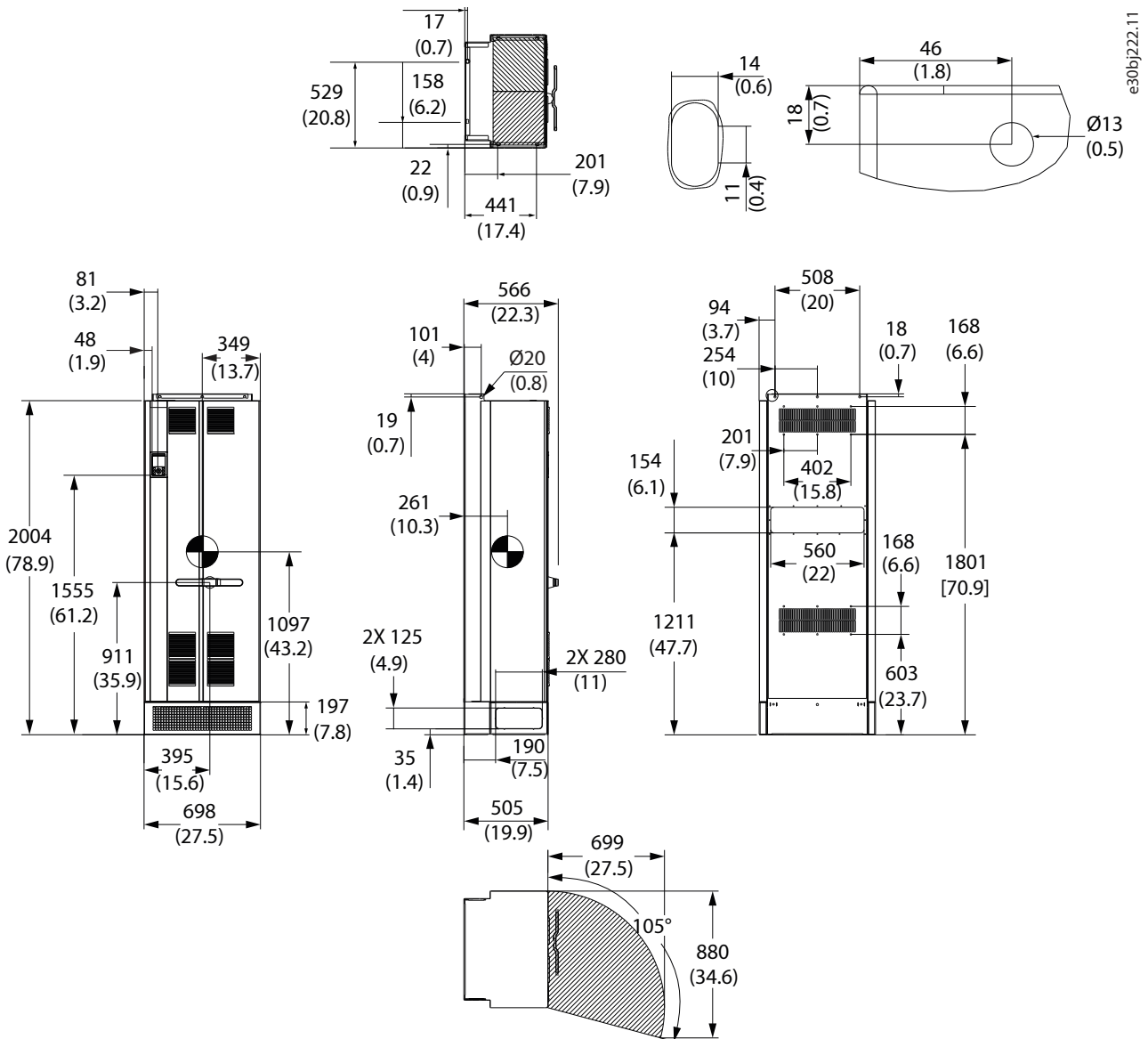

Figure 41: FK11 Dimensions

## 9.3.9 FK12 Dimensions



e30bj222.11

Figure 42: FK12 Dimensions

## 9.4 IP54/IP55/UL Type 12 Frames (FB09–FB12)

### 9.4.1 FB09a Dimensions

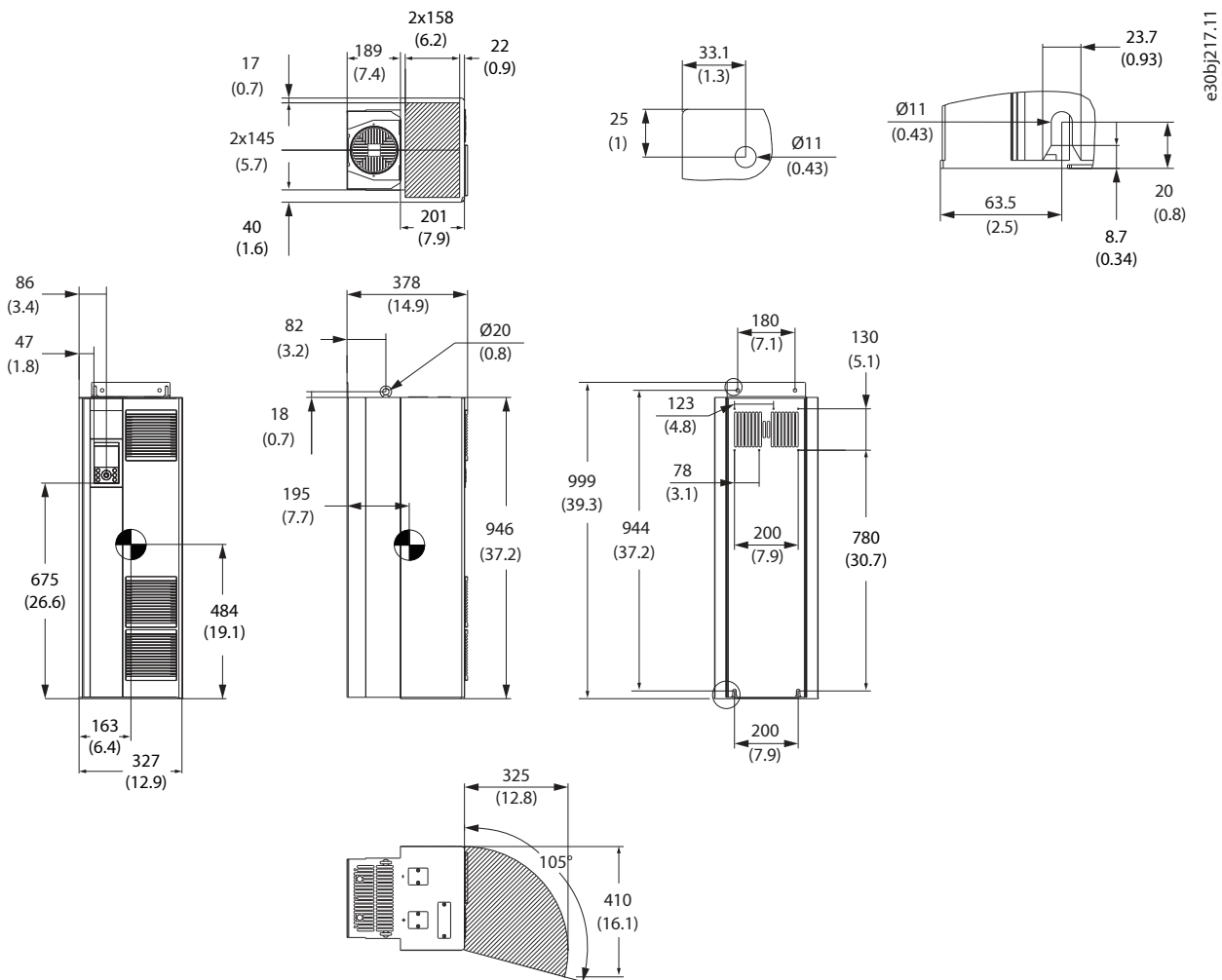

Figure 43: FB09a Dimensions

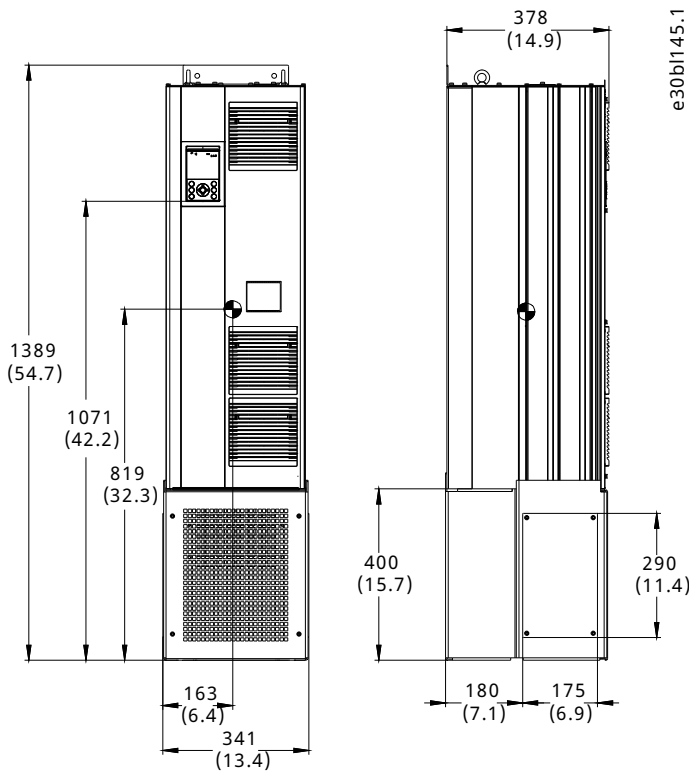
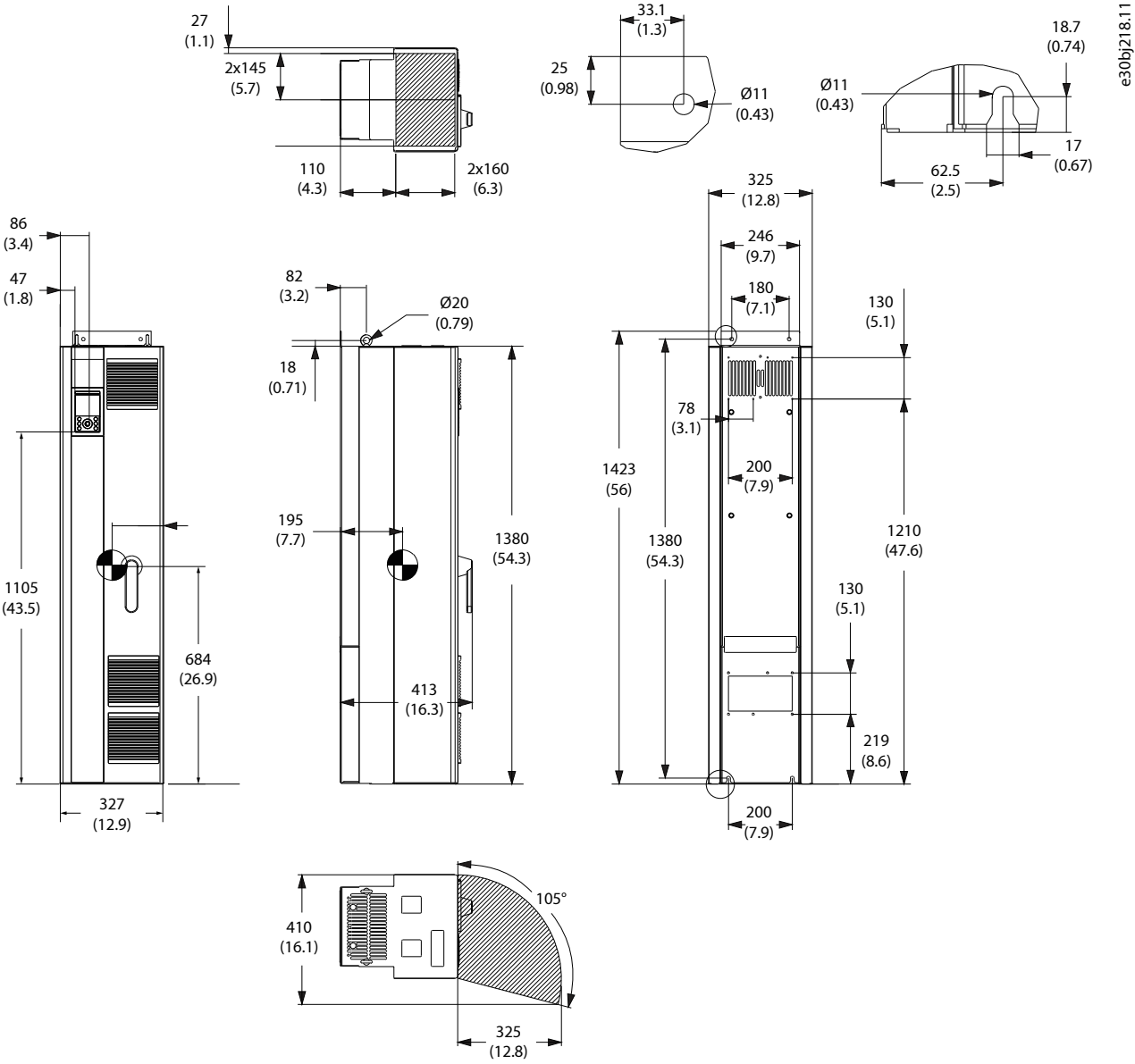

Figure 44: FB09a Dimensions with Optional Pedestal

9.4.2 FB09c Dimensions



e30bj218.11

Figure 45: FB09c Dimensions

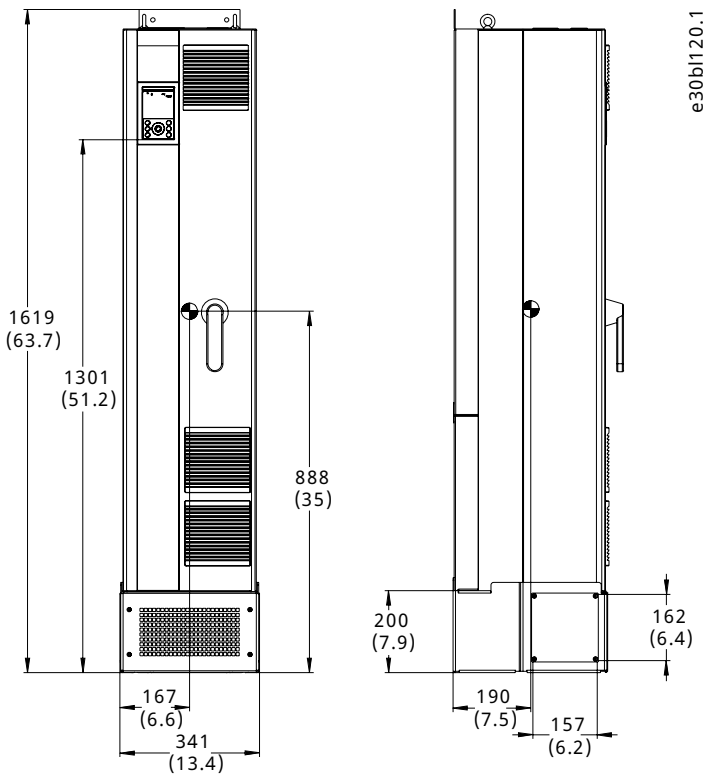

Figure 46: FB09c Dimensions with Optional Pedestal

9.4.3 FB10a Dimensions

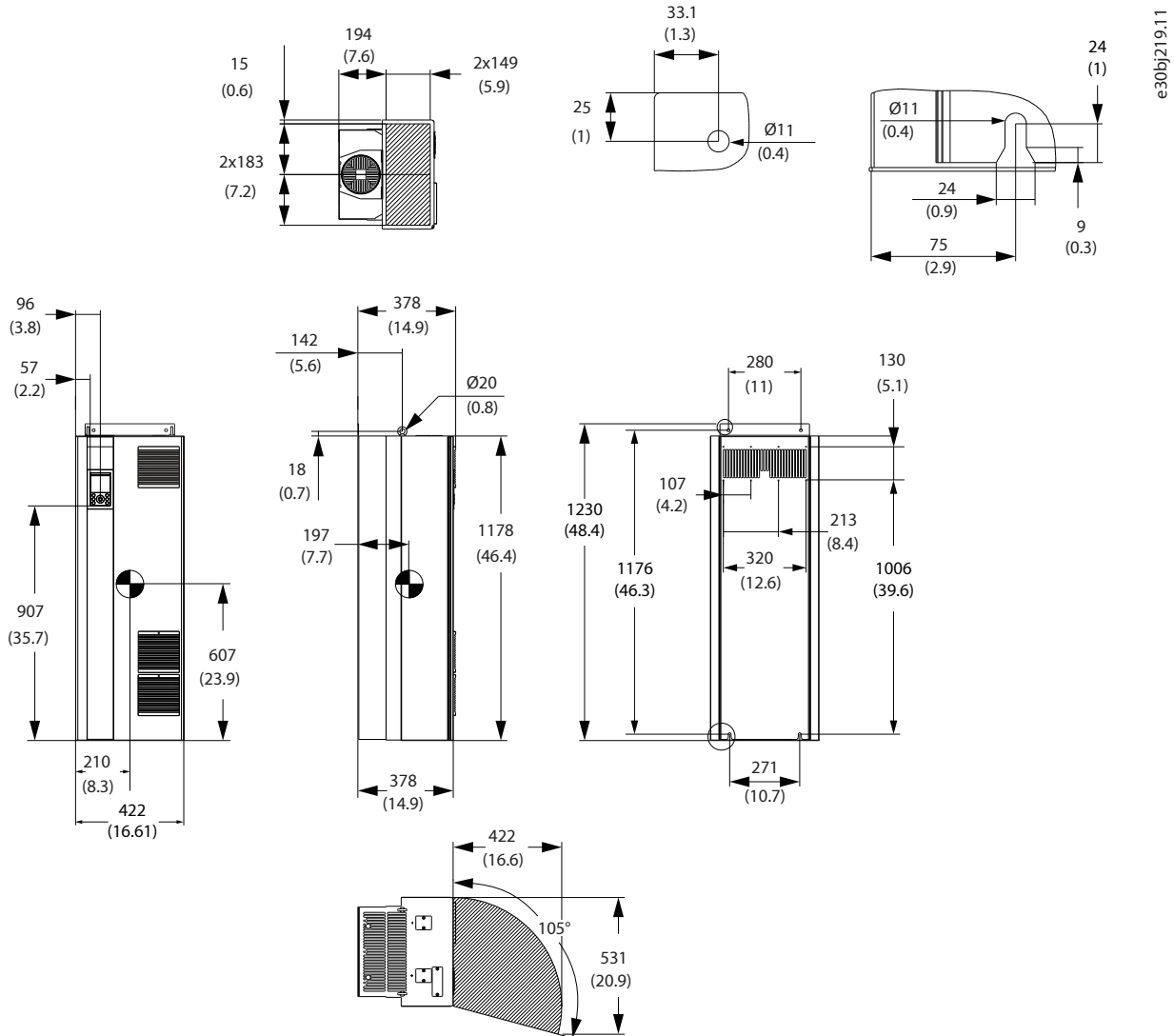

Figure 47: FB10a Dimensions



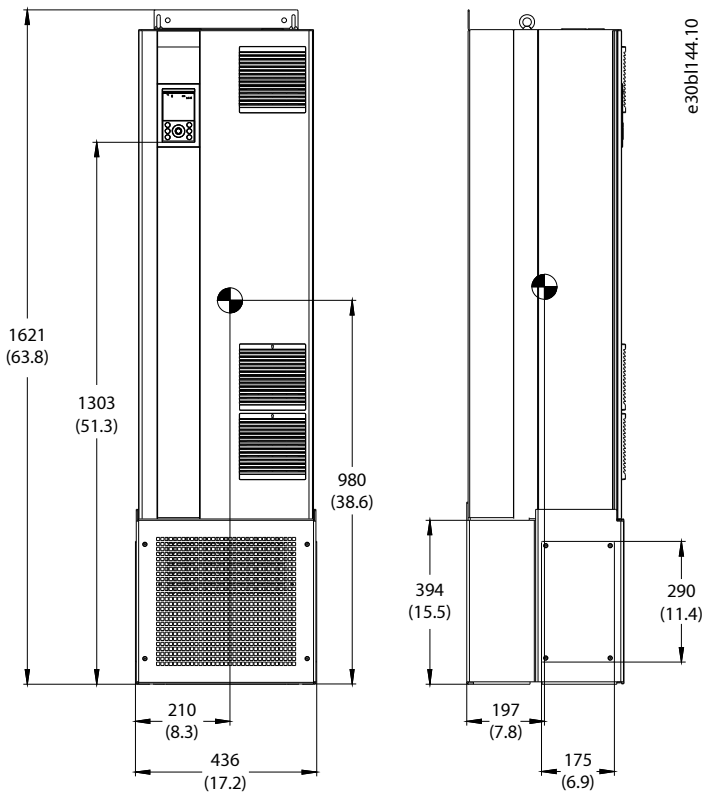

Figure 48: FB10a Dimensions with Optional Pedestal

9.4.4 FB10c Dimensions

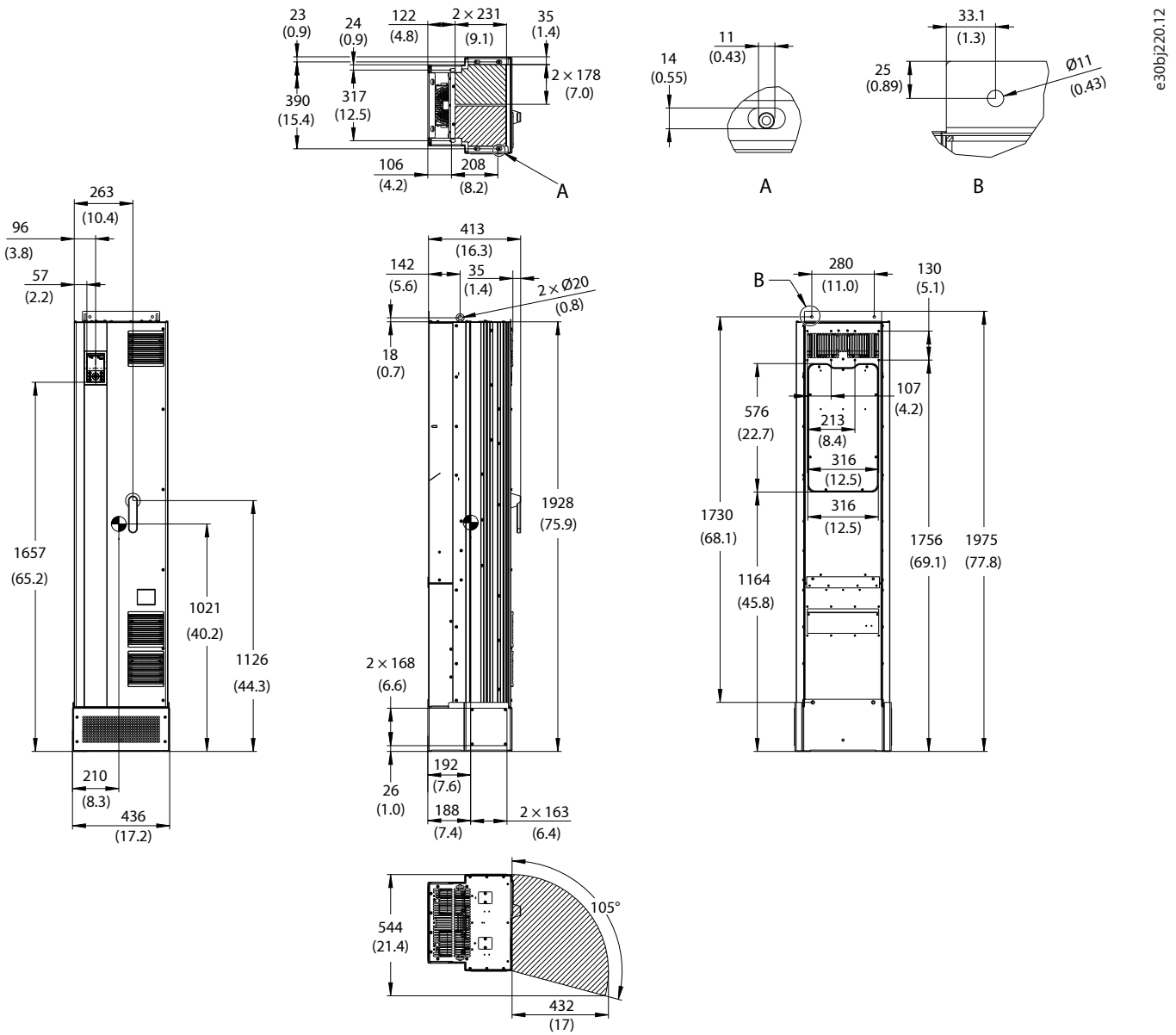
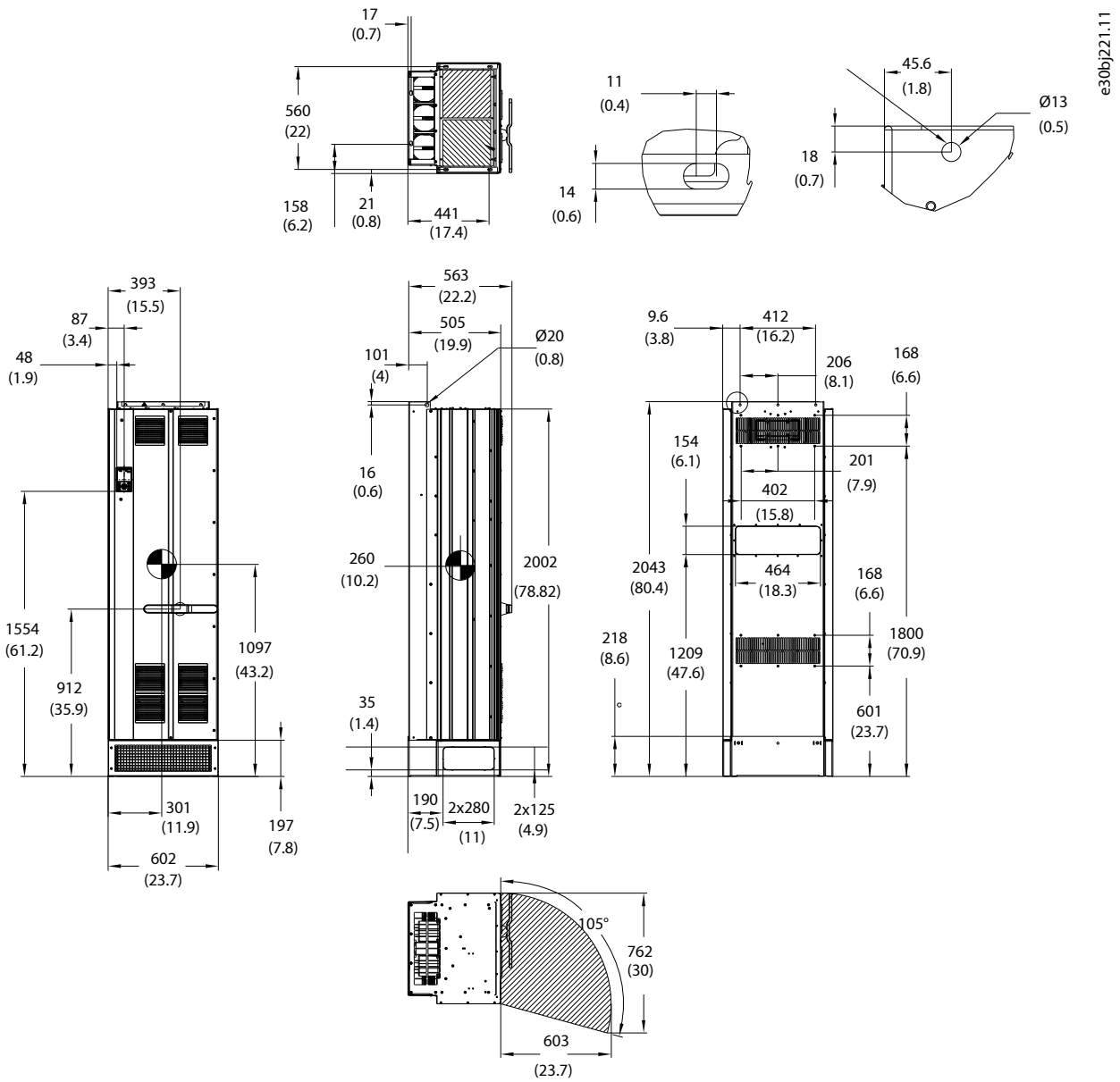

Figure 49: FB10c Dimensions

9.4.5 FB11 Dimensions



e30bj221.11

Figure 50: FB11 Dimensions

9.4.6 FB12 Dimensions

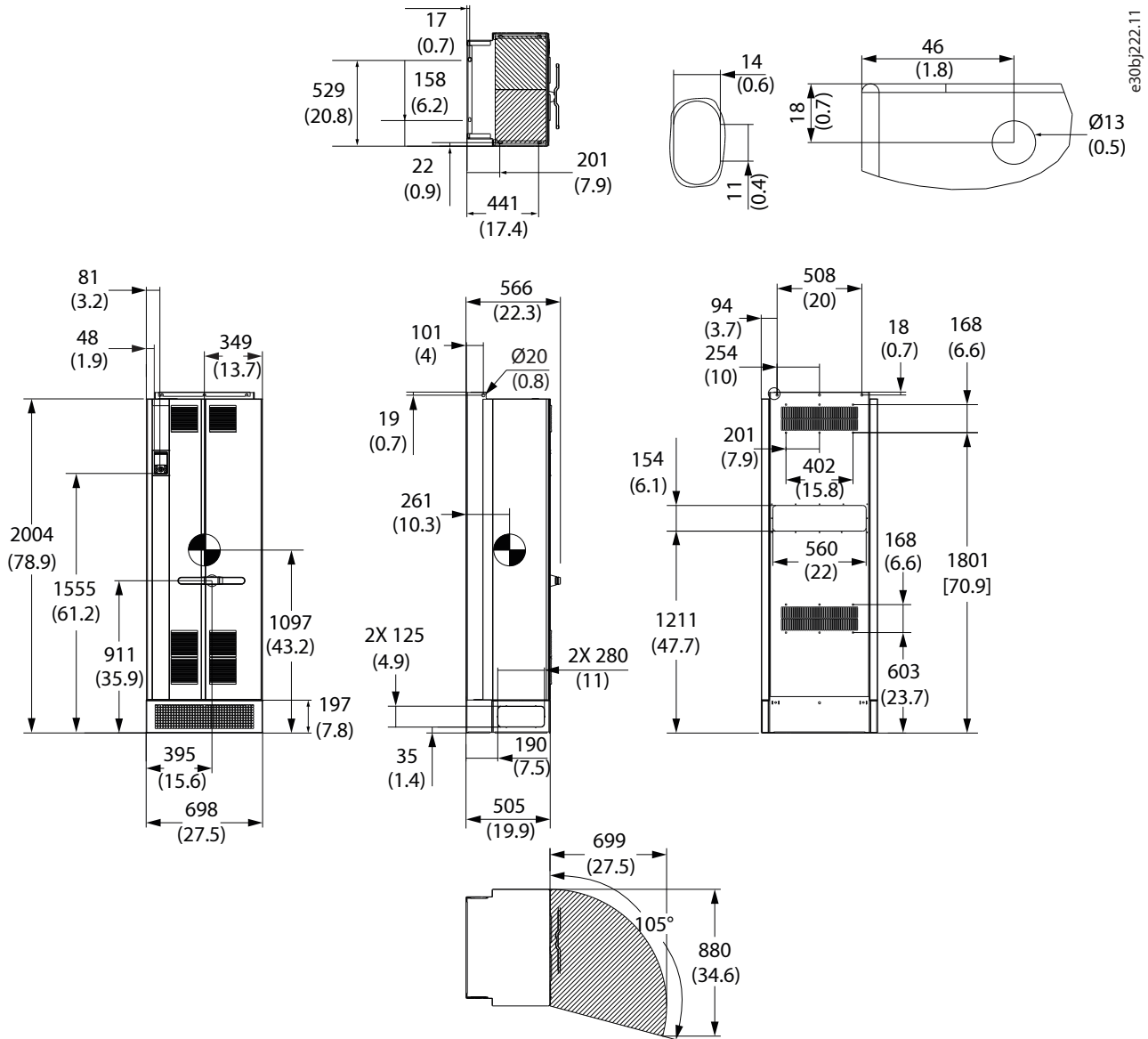

e30bj222.11

Figure 51: FB12 Dimensions

## 10 Mechanical Installation Considerations

### 10.1 Contents of the Shipment

The shipment contains:

- The drive including functional extension options (if ordered).
- Accessories needed for installing the drive (for example, connectors, EMC plates, cable clamps).
- The safety guide, which provides important safety information related to installing the drive.
- The installation guide, which provides instructions related to the mechanical and electrical installation of the drive.

### 10.2 Product Labels

#### 10.2.1 Overview

The drive, control panel, and functional extension options have labels that contain information required for legal or regulatory reasons, a unique identification of each component, and other relevant information.

#### 10.2.2 Product Labels on Drives

The product label on the drive contains information to identify the product, and legal and regulatory information. Depending on the frame, the label is either on the top of the drive or on the front cover of the drive as shown in [Figure 52](#). Frames Fx09–Fx12 have a second label inside the drive. Refer to the drawings available at <https://www.danfoss.com/en/service-and-support/documentation/> for the exact location of the label inside the drive.

When reinstalling the cover for frames FA09–FA12, make sure that the product label on the front cover matches the label inside the drive.

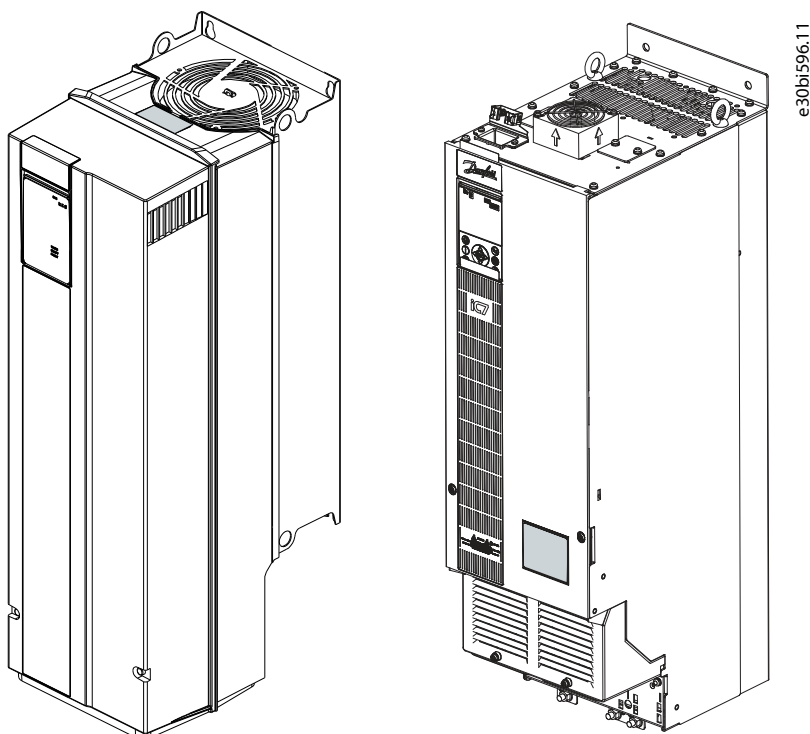

Figure 52: Locations of the Product Labels

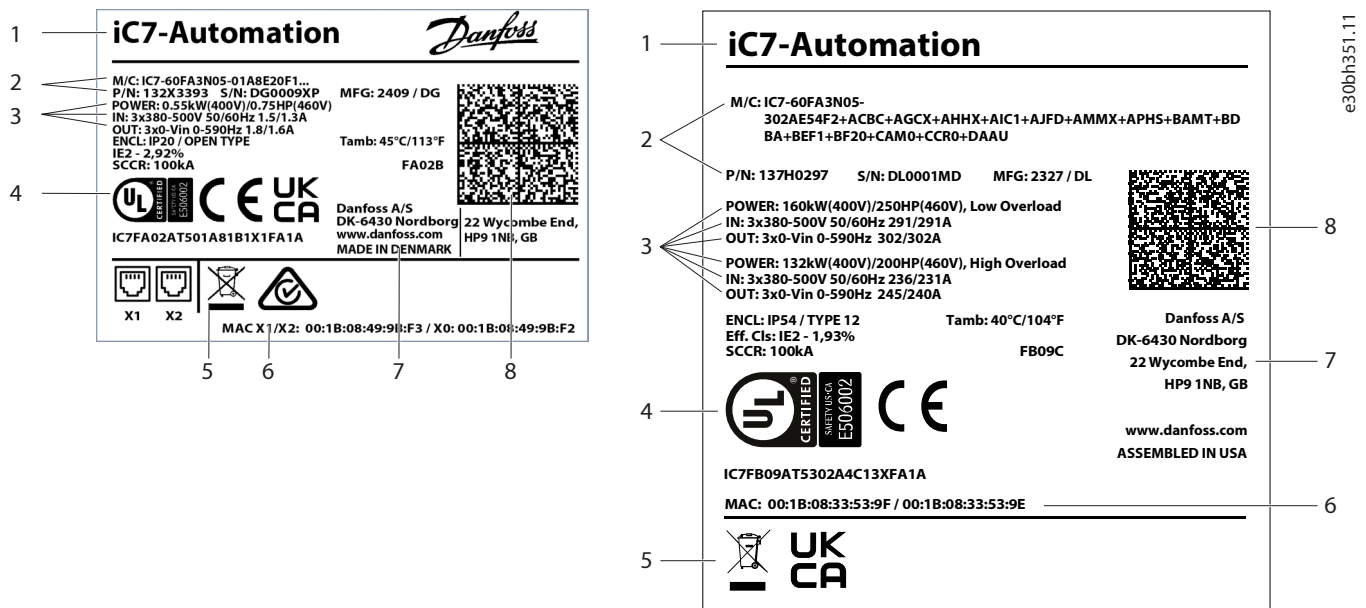

Figure 53: Product Labels for Fx02–Fx08 (Left) and Fx09–Fx12 (Right)

- 1 Product name
- 2 M/C, P/N, S/N, MFG
  - M/C includes the first 22 characters of the model code for frames Fx02–Fx08. For Fx09–Fx12, the complete model code is shown on the label. The complete model code can be read out from a parameter in the drive or from the 2D code.
  - P/N is the code number of the actual product.
  - S/N is the serial number.
  - MFG specifies the manufacturing year and week followed by assembly site ID.
- 3 Product data
  - The rating is given on 3 lines:
    - The 1st line lists the typical motor power rating at the referenced voltages.
    - The 2nd line lists input ratings (voltage range, frequency, and input current at given input voltages).
    - The 3rd line lists output ratings (voltage range, frequency, and rated output currents at the given input voltages).
 If the drive is rated with different currents in LO and HO mode, both ratings are stated.
  - Enclosure: States the protection rating of the drive both as an Ingress Protection rating and a UL compliant rating.
  - Ambient temperature: States the ambient temperature range without derating needed. For complete data, see [10.6.1 Overview of Derating for Operating Conditions](#).
  - Efficiency class: Efficiency class according to the ErP directive. The value given for 90% frequency/100% current working point. For more details, see MyDrive® Select.
  - Frame designation: Frame designation of the drive, making reference to documentation easy.
  - SCCR: The SCCR describes the maximum allowed short-circuit rating. For more information on short-circuit ratings with a specific fuse, see [8.4.1 Overview](#)
- 4 UL and CE compliance
 

Compliance codes are stated together with detailed information on approval limitations (if any).
- 5 Other warnings and compliance information
- 6 MAC address
 

MAC address of Ethernet communication ports of the drive.

- 7 Company name and address
- 8 2D code – accessible by using a Datamatrix ECC 200 compatible barcode reader – containing the model code, code number, serial number, and manufacture year and week.

The control panel and functional extensions have dedicated labels. For details, see [10.2.4 Product Labels on Functional Extensions](#) and [10.2.5 Product Labels on Control Panels](#).

### 10.2.3 Package Labels

The package label is placed on the drive packaging, and contains information about the drive.

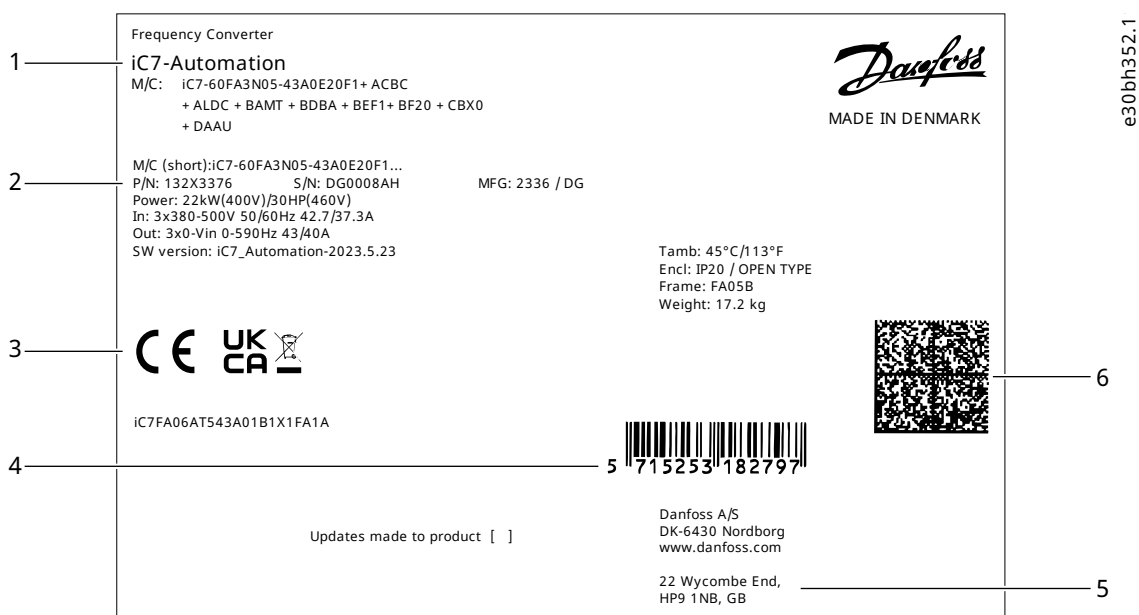

Figure 54: Example of a Package Label

1	Product name and other product-specific data	2	Code number, serial number, and manufacturing year and week (YYWW)
3	Approval marking required on packaging More approval markings are shown on the drive.	4	Barcode with EAN information
5	Company name and address	6	2D code – accessible by using a Datamatrix ECC 200 compatible barcode reader – containing the model code, code number, serial number, and manufacture year and week

### 10.2.4 Product Labels on Functional Extensions

Each functional extension has a product label that includes essential information about the option.

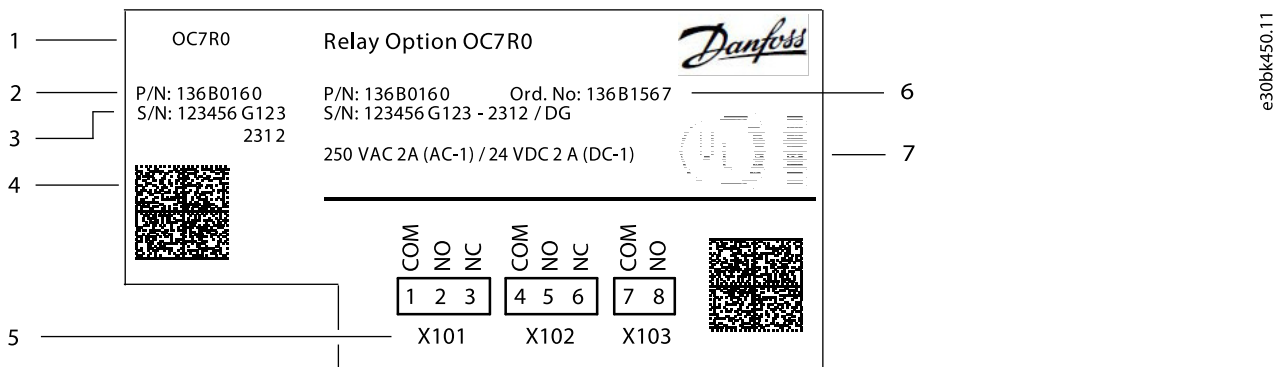

Figure 55: Example of a Product Label on a Functional Extension

1	Product name of the functional extension	2	Code number identifying the option
3	Serial number	4	2D code containing code number, serial number, production year and week, and product name
5	Identification of I/O connections on the option	6	Order number identifying the option kit that was ordered
7	Compliance and approval markings (if not covered by drive approvals)		

For further details, refer to option documentation.

### 10.2.5 Product Labels on Control Panels

The product label is on the back of the control panel.



Figure 56: Example of a Control Panel Label

The label contains the following information:

- Product name, code number, and serial number.
- Company name and address.
- 2D code – accessible by using a Datamatrix ECC 200 compatible barcode reader – containing the code number, serial number, and manufacturing year and week.
- Compliance and approval markings.
- Radio communication and MAC address information.

**NOTE:** The radio communication and MAC address information only apply to control panel options with wireless communication capabilities.



## 10.3 Disposal

### 10.3.1 Recommended Disposal

When the product reaches the end of its service life, its primary components can be recycled.

Before the materials can be removed, the product must be disassembled. Product parts and materials can be dismantled and separated. Generally, all metals, such as steel, aluminum, copper and its alloys, and precious metals can be recycled as material. Plastics, rubber, and cardboard can be used in energy recovery. Printed circuit boards and large electrolytic capacitors with a diameter of under 2.5 cm (1 in) need further treatment according to IEC 62635 guidelines. To ease recycling, plastic parts are marked with an appropriate identification code.

Contact your local Danfoss office for further information on environmental aspects and recycling instructions for professional recyclers. End-of-life treatment must follow international and local regulations.

All products are designed and manufactured in accordance with Danfoss company guidelines on prohibited and restricted substances. A list of these substances is available at <https://www.danfoss.com>.



This symbol on the product indicates that it must not be disposed of as household waste. Do not dispose of equipment containing electrical components together with domestic waste.

It must be handed over to the applicable take-back scheme for the recycling of electrical and electronic equipment.

- Dispose of the product through channels provided for this purpose.
- Comply with all local and currently applicable laws and regulations.

### 10.3.2 Real-time Clock Battery Disposal

Dispose of the old battery according to local disposal rules or applicable laws.



#### RISK OF FIRE OR EXPLOSION

- Do not recharge or disassemble the battery, or dispose of it in fire.

## 10.4 Storage until Installation

### 10.4.1 Reforming the Capacitors

For drives that are in storage and do not have voltage applied, maintenance of the capacitors in the drive may be required.

Reforming is required if the drive has been stored without applying voltage for more than 3 years. Reforming is possible only with drives with DC terminals. See [Table 53](#) for DC-link capacitor maintenance and reforming.

When reforming the capacitors:

- The reforming voltage must be 1.35–1.45 times the rated mains voltage. If the DC-link voltage stays at a low level and does not reach approximately  $1.41 \times U_{\text{mains}}$ , contact the local service agent.
- The supply current draw must not exceed 500 mA.

When the drive is operational, DC-link capacitors that have not been reformed can be damaged.

Table 53: Drive Storage Duration and Reforming Recommendations

Storage duration	Reforming guideline
Under 2 years	No reforming required. Connect to mains voltage.
2–3 years	Connect to mains voltage and wait a minimum of 30 minutes before loading the drive.
Over 3 years	Using a DC supply connected directly to the DC-link terminals of the drive, ramp up the voltage 0–100% of DC-bus voltage in increments of 25%, 50%, 75%, and 100% rated voltage under no load for 30 min at each increment. See <a href="#">Figure 57</a> .

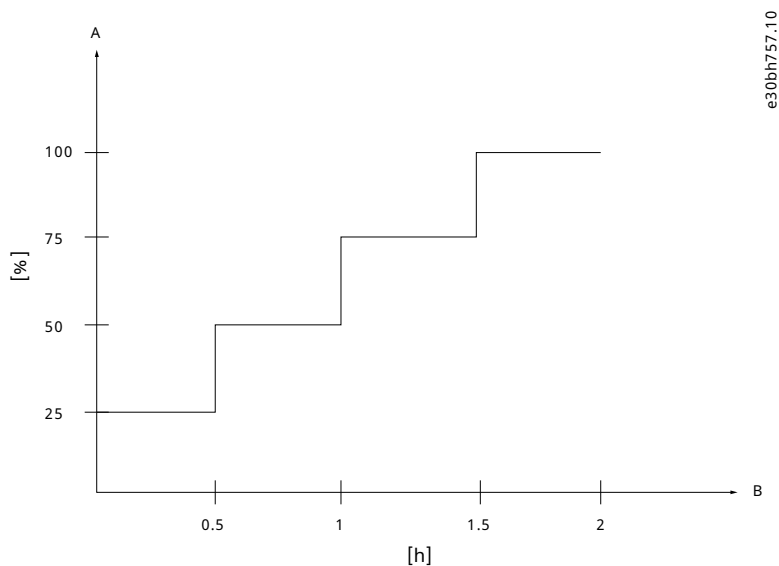

Figure 57: Reforming Procedure for DC Capacitors

A	Reforming voltage (percentage of rated voltage)	B	Hours
---	-------------------------------------------------	---	-------

Table 54: DC Bus Voltage Ramp-up Value

AC input voltage	Voltage across the DC link
380–500 V AC	680 V DC

## 10.4.2 Safe Transportation and Storage

Follow all information on transportation, storage, and proper handling given in the product-specific documentation. That includes:

- If the drive is stored before installing it, make sure that the ambient conditions agree to the specifications given in [8.3.8.2 Ambient Conditions during Storage](#).
- If the package is kept in storage for more than 4 months, keep it in controlled conditions:
  - Make sure that the temperature variation is small.
  - Make sure that the humidity is less than 50%.
- Only use lifting and handling equipment rated and suitable for the purpose.
- Check the weight of the drive and lift the drive with a lifting device, if needed. In this case, use the lifting eyes/bars designed for this purpose.
- Check the center of gravity on the packaging or on the drive before lifting the drive and avoid tilting to prevent the drive from overturning.

- Keep the drive in its package until installation. After unpacking, protect the drive from dust, debris, and moisture.

## 10.5 Prerequisites for Installation

### 10.5.1 Overview

To secure the best conditions and operation of the drive in its application, it is recommended to check the following points before selecting a drive:

- Check the operating environment against ambient conditions. See [8.3.8.4 Ambient Conditions during Operation](#).
- Consider the placement of the drive, and handling during installation, including the need for lifting devices. See [8.8 Packaging](#) for the weights and mechanical dimensions of the packaging, and chapter *Exterior and Terminal Dimensions* for the dimensions of the drives.
- Consider the needs for access to the drive during operation. See [10.8.1 Overview](#).
- Consider the needs for maintenance access. See [10.8.9 Recommended Space for Service Access](#).

### 10.5.2 Operating Environment

Make sure that the drive is installed within the specified installation conditions to ensure proper operation and expected lifetime of the product.

Table 55: Operating Environment Specifications

Environment	Specifications
Temperature	The drive must be installed in a location where the operational temperature range is compliant to the specifications of the drive. Consider both temperature at operation and temperature at storage (unpowered drive). If the nominal temperature rating is exceeded, derating must be applied. For more information about derating, see <a href="#">8.3.8.1 Overview</a> and <a href="#">10.6.2 Derating for Ambient Temperature</a> .
Altitude	Ensure that the drive is installed at the allowed altitude for proper cooling and compliance with isolation spacing. At altitudes above 1000 m (3300 ft), derating of drive performance applies. Derating is to be applied to the maximum output current or maximum operational temperature. Ensure that the drive is rated for the actual application. Maximum altitude depends on power grid configuration and grid voltage. Limitations are stated in <a href="#">8.3.8.4 Ambient Conditions during Operation</a> . For more information, see <a href="#">8.3.8.1 Overview</a> and <a href="#">10.6.3 Derating for Altitude</a> .
Vibration and shock	Ensure that the drive is installed in a location where it is not exposed to vibration and shock levels exceeding its specifications. If exposed to higher levels of vibration and shock, using dampers for installation is recommended. Special requirements are fulfilled when the drive is ordered with marine approval. For more information, see <a href="#">8.3.8.1 Overview</a> .
Humidity	The drive must be installed in a location where the humidity level is compliant to the specifications of the drive. If the installation area does not fulfill the required conditions, alternative measures can be taken by selecting other protective cabinets for installation, built-in heating elements, or a dehumidifier. For more information, see <a href="#">8.3.8.1 Overview</a> .

Table 55: Operating Environment Specifications (continued)

Environment	Specifications
Dust, fiber, and airborne particles	<p>Depending on the protection rating class, the allowed exposure to dust, fibers, and other airborne particles varies:</p> <ul style="list-style-type: none"> <li>IP20, IP21, UL Open Type, and UL Type 1 enclosures are not protected against dust, fibers, and other airborne particles, and should be installed in locations where these are not present, or in a dedicated enclosure.</li> <li>IP54/55 and UL Type 12 are protected against dust, fibers, and other airborne particles.</li> </ul> <p>Make sure that airborne particles are not clogging the heat sink and fan, because clogging limits the cooling of the drive. The drive detects clogging, and reduces performance or stops operation. Do not install the drive in a location where it is exposed to conductive particles.</p> <p>For more information, see <a href="#">8.3.8.1 Overview</a>.</p> <p>For more information on heat sink and fan maintenance, see <a href="#">10.7.5 Heat Sink and Fan Maintenance and Service</a>.</p>
Gases	<p>When installing the drive, exposure to gases must be observed. The drive is not intended to be installed in a location where it is exposed to explosive gases. If exposed to corrosive gases, relevant precautions must be taken. These precautions include selecting a drive with a higher protection rating, adding protective coating as an optional selection to the drive, or by installing the drive in a protective cabinet.</p> <p>For more information, see <a href="#">8.3.8.1 Overview</a>.</p>

## 10.6 Derating for Operating Conditions

### 10.6.1 Overview of Derating for Operating Conditions

If the drive is used outside the nominal specifications, derating must be considered.

Derating must be applied when:

- The maximum ambient temperature is 50 °C (122 °F), or 45 °C (113 °F), depending on the frame. Derating is required when operating at 24 h average ambient temperatures above 45 °C (113 °F) or 40 °C (104 °F), depending on frame.
- Operating at altitudes above 1000 m (3300 ft).
- Operating at a low output frequency (< 5 Hz).
- Operating with increased switching frequency.

Derating typically means operation and reduced output current and limited maximum temperature.

For detailed information about derating for a specific operating condition, see:

- [10.6.2 Derating for Ambient Temperature](#)
- [10.6.3 Derating for Altitude](#)
- [10.6.4 Derating for Output Frequency](#)
- [10.6.5 Derating for Switching Frequency](#)

MyDrive® Select supports making a more precise selection when selecting a frequency converter for operating conditions other than the nominal specifications. MyDrive® Select includes detailed data on the iC7 drives.

### 10.6.2 Derating for Ambient Temperature

If the frequency converter is operated above the maximum nominal temperature (45 °C/113 °F average temperature over 24 hours), derating is required.

If the average temperature within 24 hours does not exceed 45 °C (113 °F), operation at a maximum temperature of up to 50 °C (122 °F) is allowed for 1 hour. The temperature is 5 °C (9 °F) lower for frames FK12 (IP21/UL Type 1) and FB12 (IP54/UL Type 12) with product code 05–1260.

For more information on derating for higher temperatures and altitude, including the derating curves, see [10.6.3 Derating for Altitude](#). The maximum allowed temperature is 60 °C (140 °F).

In emergency situations, it is possible to override protections, and operate the drive at temperatures up to 70 °C (158 °F). Operation at this temperature is controlled with a dedicated setting in the software, and affects warranty.

### 10.6.3 Derating for Altitude

Cooling efficiency is reduced at higher altitudes. As a result, derating is required above 1000 m (3300 ft).

The maximum allowed altitude is 4400 m (14400 ft) at a system voltage (phase-ground voltage of grid) up to 300 V according to IEC 61800-5-1 on electrical safety. At system voltages above 300 V, the altitude is restricted to 2000 m (6500 ft). All 200–240 V grid types and 3-phase star-connected grids (TN, TT, IT) up to 500 V exhibit a system voltage of less than 300 V. All 3-phase delta grids above 380 V exhibit a system voltage above 300 V.

If the maximum nominal temperature is kept below 45 °C (113 °F), or alternatively below 50 °C (122 °F) for a maximum of 1 hour, derating of output current can be reduced. The temperature is 5 °C (9 °F) lower for frames FK12 (IP21/UL Type 1) and FB12 (IP54/UL Type 12) with product code 05–1260.

When selecting a frequency converter, follow the guidelines for derating based on ambient temperature and altitude. If needed, select an oversized drive.

If the average temperature within 24 hours does not exceed 45 °C (113 °F), operation at a maximum temperature of up to 50 °C (122 °F) is allowed for 1 hour.

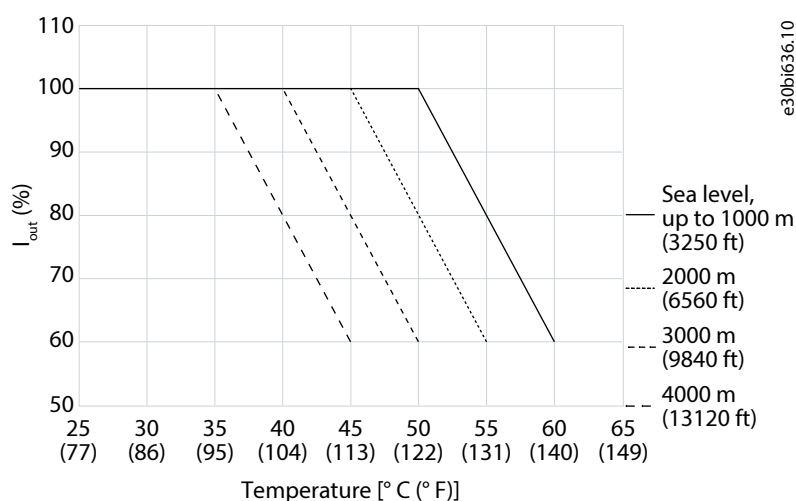

Figure 58: Derating of Output Current Versus Altitude and Ambient Temperature (Frames FA02–FA08, FK06–FK08)

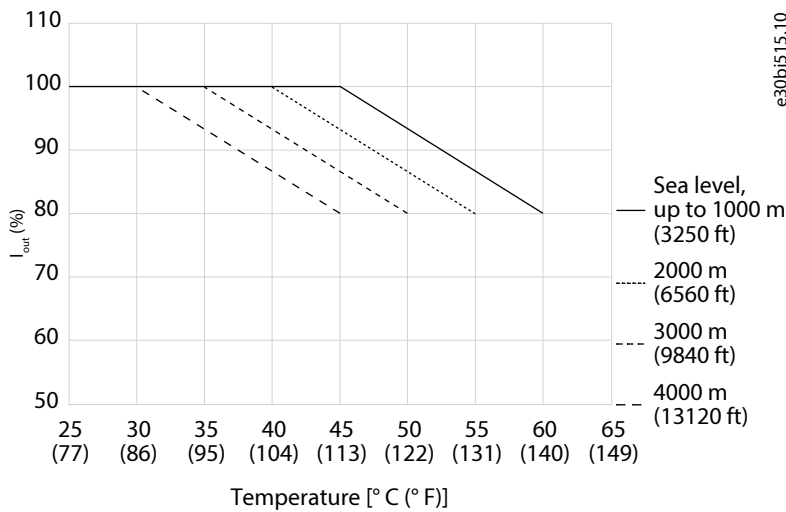

Figure 59: Derating of Output Current Versus Altitude and Ambient Temperature (Frames Fx09-Fx12, Low Overload)

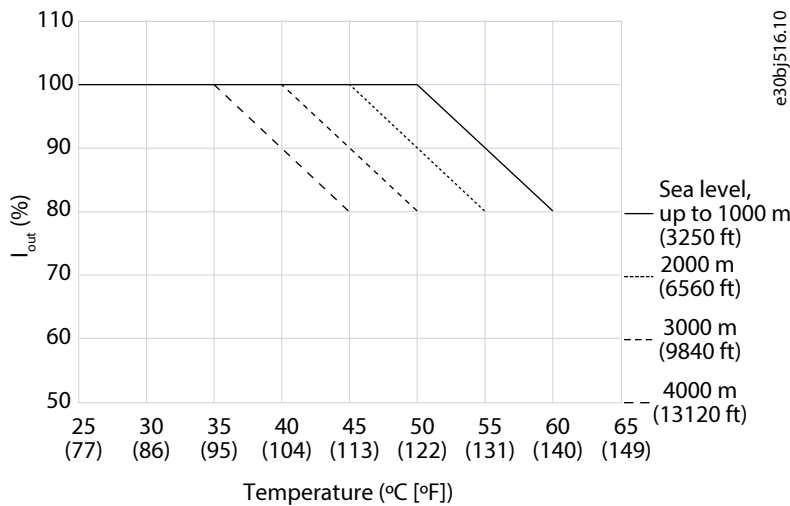

Figure 60: Derating of Output Current Versus Altitude and Ambient Temperature (Frames Fx09-Fx12, High Overload)

### 10.6.4 Derating for Output Frequency

At low-speed operation (output frequencies below 5 Hz) and high output current, the frequency converter is thermally loaded in an unusual way. To avoid limiting the lifetime of the frequency converter, derating of the output current is required.

Depending on duration and the temperature of the heat sink, the drive may automatically derate the transient current capacity when ramping up or down the motor (below 5 Hz).

For more specific guidance, use MyDrive® Select.

### 10.6.5 Derating for Switching Frequency

Derating of the output current is required, when the drive is operated above nominal switching frequency.

See the following graphs for recommended derating for each frame designation.

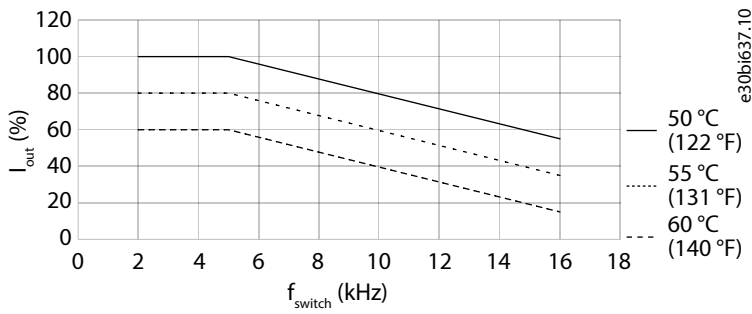

Figure 61: Derating of Output Current Versus Switching Frequency (FA02-FA04) with Low Overload (LO) and High Overload (HO1)

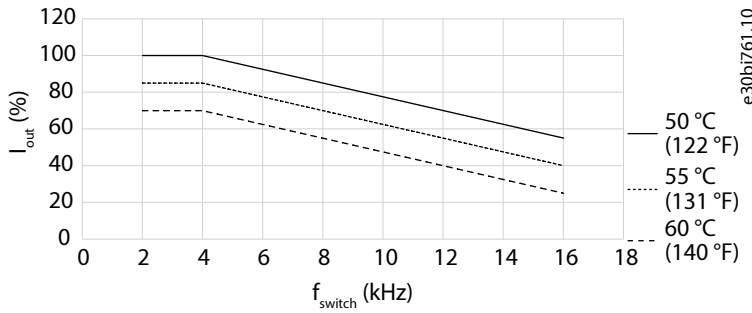

Figure 62: Derating of Output Current Versus Switching Frequency (FA05) with Low Overload (LO) and High Overload (HO1)

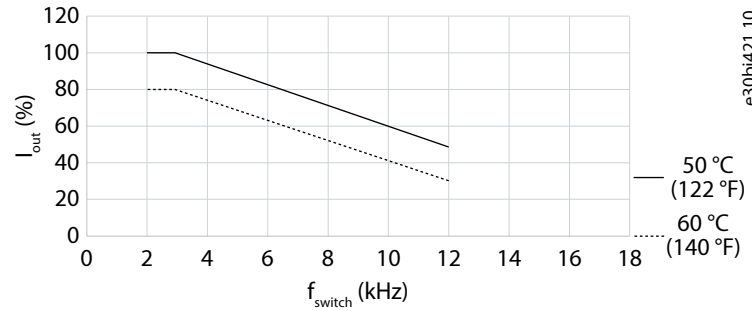

Figure 63: Derating of Output Current Versus Switching Frequency (Fx06-Fx08) with Low Overload (LO) and High Overload (HO1)

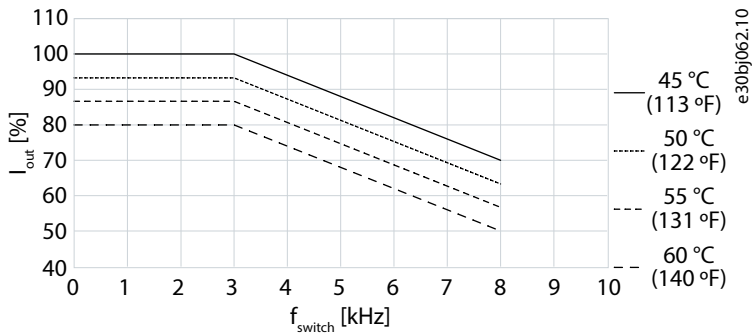

Figure 64: Derating of Output Current Versus Switching Frequency for Fx09-Fx10 with Low Overload (LO)

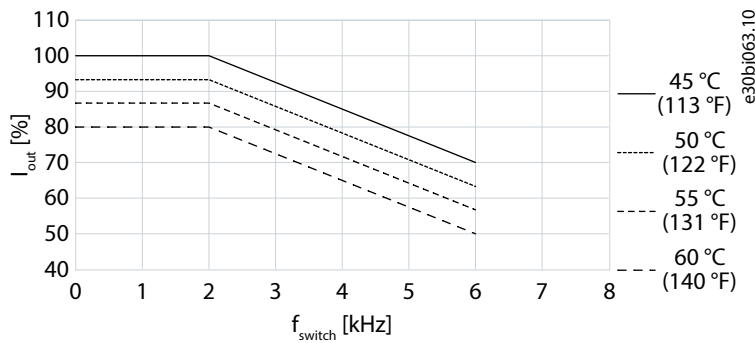

Figure 65: Derating of Output Current Versus Switching Frequency for Fx11-Fx12 with Low Overload (LO)

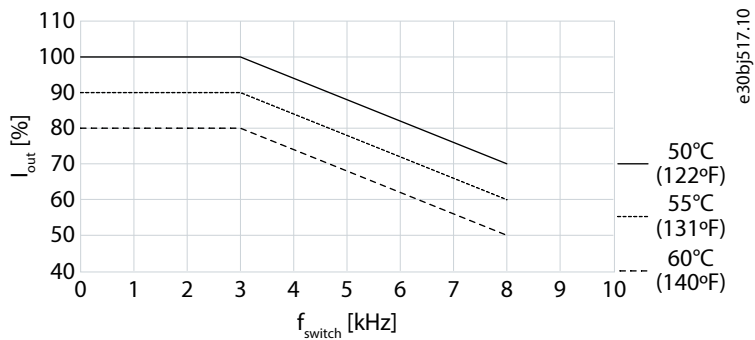

Figure 66: Derating of Output Current Versus Switching Frequency for Fx09-Fx10 with High Overload (HO1)

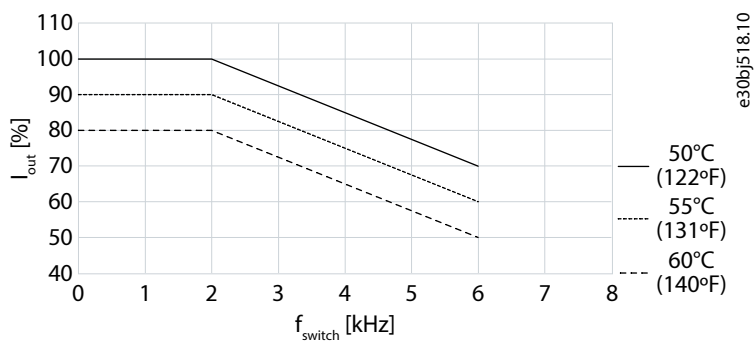

Figure 67: Derating of Output Current Versus Switching Frequency for Fx11-Fx12 with High Overload (HO1)

## 10.7 Maintenance Considerations

### 10.7.1 Maintenance Considerations

During the lifetime of the drive, regular maintenance or service actions may be needed, and access to relevant parts of the drive must be ensured.

#### CAUTION



#### HOT SURFACES

The drive contains metal components that are still hot even after the drive has been powered off. Failure to observe the high-temperature symbol (yellow triangle) on the drive can result in serious burns.

- Be aware that internal components, such as busbars, may be extremely hot even after the drive has been powered off.
- Do not touch exterior areas that are marked by the high-temperature symbol (yellow triangle). These areas are hot while the drive is in use and immediately after being powered off.



## 10.7.2 Regular Maintenance

Typical cases for maintenance include:

- Checking the I/O signal on the drive.
- Adding functional extensions options.
- Regularly checking the power connections and grounding.
- Reading data or parameterizing by connecting a PC to the drive.
- Using the memory card to, for example, copy drive settings.

## 10.7.3 Maintenance Schedule

The maintenance schedule of the drive depends on the use and operating environment of the drive. The maintenance schedule given in [Table 56](#) applies when the drive is operated within nominal specifications.

**Table 56: Maintenance Schedule**

Maintenance interval	Maintenance task
6–24 months (depending on environment)	<ul style="list-style-type: none"> <li>• Check the tightening torques of the power terminals.</li> <li>• Make sure that the cooling fan operates correctly.</li> <li>• Check for corrosion on terminals, busbars, and other surfaces.</li> <li>• Clean the heat sink and the cooling channel.</li> </ul>
6–10 years	<ul style="list-style-type: none"> <li>• Change the cooling fans.</li> <li>• Exchange the backup battery in the interface board. See <a href="#">10.7.6 Backup Battery Exchange</a>.</li> </ul>

A maintenance plan for each drive supports the optimum performance and lifetime of the drive. Danfoss offers several service products to, for example, the DrivePro® preventive maintenance service to provide help in determining the correct setup. For more information on DrivePro® services, see [www.danfoss.com](http://www.danfoss.com). For more information, contact Danfoss.

## 10.7.4 Service Access

To ensure planned and extended drive lifetime, Danfoss recommends regular inspection and service actions for the drive, motor, system, and cabinet/enclosure. To prevent breakdown, danger, and damage, examine, for example, the tightness of terminal connections and dust build-up in the drive at regular intervals depending on the operating conditions.

If the Danfoss drive is operated in environments near the limit or beyond design boundaries, maintenance of the drive is required.

Replace worn or damaged parts with original spare parts. For service and support, contact the local supplier. DrivePro® services extend the lifetime and increase the performance of iC7-Automation with commissioning and timely scheduled maintenance services. DrivePro® services are tailored to applications and operating conditions.

When planning the installation, proper access for service and maintenance needs must be considered. In general, it is recommended to ensure:

- Access to power cabling and connectors.
- Access to control wiring.
- Access to clean the cooling system (cooling channel and fan filters).
- Access to the port to connect the drive to a PC.

## 10.7.5 Heat Sink and Fan Maintenance and Service

The heat sink fins pick up dust from the cooling air. If the heat sink is not clean, the drive runs into overtemperature warnings and faults. When necessary, clean the heat sink.

The lifespan of the cooling fan of the drive depends on the running time of the fan, ambient temperature, and dust concentration. Fans can be removed from the drive for cleaning. Replacement fans are available from Danfoss.

### 10.7.6 Backup Battery Exchange

If the battery of the interface board needs to be replaced, use the type and brand of battery defined in [8.3.7 Interface Board](#).

Using a different battery may cause a risk of fire or explosion. Only qualified personnel are allowed to exchange the battery.

#### CAUTION

##### RISK OF FIRE AND EXPLOSION

- Replace the battery with a Panasonic BR1632A (3 V, 125 °C) coin-cell battery only. Using another battery may present a risk of fire or explosion. Only qualified personnel can exchange the battery.
- For detailed safety information, refer to the documentation provided with the battery.

#### CAUTION

##### RISK OF FIRE OR EXPLOSION

- Do not recharge or disassemble the battery, or dispose of it in fire.

## 10.8 Mechanical Installation

### 10.8.1 Overview

The drive is mounted primarily on a wall or an enclosed cabinet, or on structures (for example, metal frames or beams). See [Table 57](#) for more information on mounting surfaces for the different frames.

The products have been designed for installation type E/F according to IEC 60204-1/60364-5-52/61439-1 and NPFA 70, with a maximum of three sets of power cables in parallel in one tray.

If frames FK09–FK12 are installed on the floor, a dedicated pedestal is required.

Table 57: Mounting Surfaces for Drives

Frame designation	Cabinet	Wall	Structure	Floor
FA02–FA12	X	–	–	–
FK06–FK08	–	X	X	–
FK09a, FK09c, FK10a	–	X	–	X <sup>(2)</sup>
FK10c, FK11, FK12	–	–	–	X
FB09a, FB09c, FB10a	–	X	–	X <sup>(2)</sup>
FB10c, FB11, FB12	–	–	–	X

1) This BDM/CDM/PDS does not provide comprehensive mitigation for fire hazards. IP20/UL Open Type drives must be installed inside a supplementary enclosure, or in a restricted access area which provides appropriate protection against the spread of fire.

2) Optional floor mounting using pedestal kits. See [12.4 Ordering Options and Accessories](#) for information on ordering the kits.

For more details on installing the drives on different surfaces, see [10.8.3 Mounting Locations](#).

## 10.8.2 Mounting Considerations

When selecting and planning the installation site, observe the following considerations:

- The mounting surface supports the weight of the drive.
- The mounting surface must be non-flammable.
- The drive is installed vertically, but in special cases it can also be mounted in alternate directions. Installing the drive in alternate directions affects the performance of the drive. For more information, see [10.8.4 Mounting Orientation](#).
- Ensure proper space for lifting the drive, especially when lifting equipment is needed.
- Follow local regulations when lifting the drive. For details, refer to the product-specific installation and safety guides.
- Proper inlet and outlet spacing secures free airflow over the heat sink to enable proper cooling.
- The drives can be mounted side-by-side to save space in cabinets, or when mounted on walls in control rooms.
- There must be enough space in front of the drive for operating the control panel.
- Ensure proper space for the installation and placement of cables used for connecting the drive.
- To remove covers or open doors for service access, enough space must be left in front of the drive.

### ⚠ WARNING



#### SHOCK HAZARD

Touching an uncovered motor, mains, or DC connection plug or terminal can result in death or serious injury.

- All plugs and terminal protection covers for the motor, mains, and DC connections must be installed within the IP20 enclosure to provide an IP20 protection rating. If plug and terminal covers are not installed, the protection rating is considered IP00.

## 10.8.3 Mounting Locations

The drives are designed for installation in weather-protected environments. For more information, see [8.3.8.1 Overview](#). When mounting the drive on the wall, or in a cabinet, the installation must be vertical and the mounting surface must be solid, flat, and non-flammable.

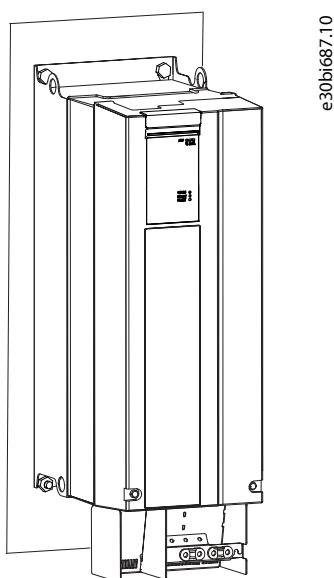
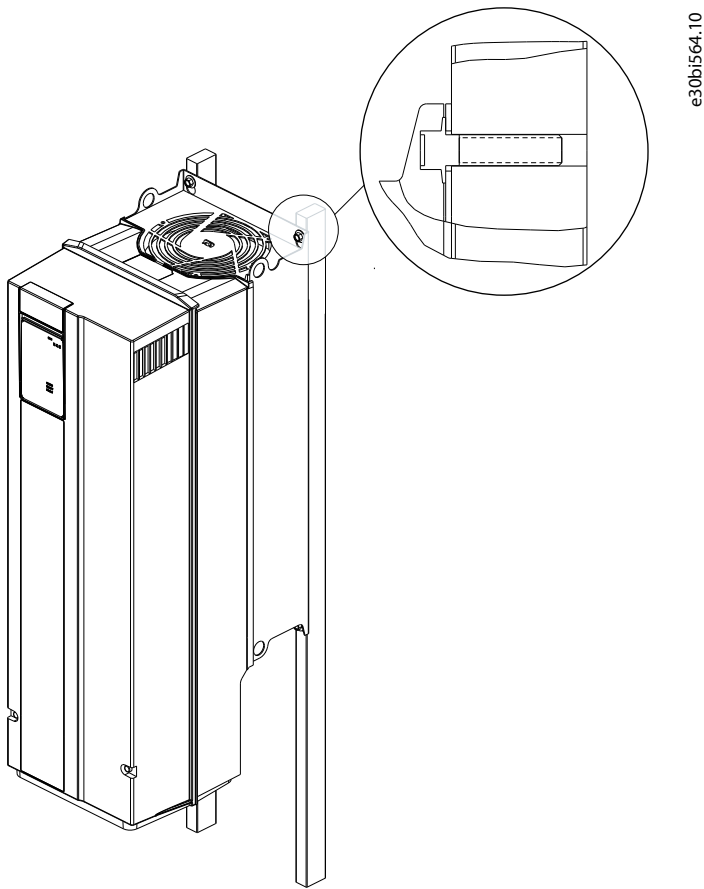

Figure 68: Mounting on the Wall or in a Cabinet

The iC7-Automation drives can also be mounted on structures (for example, metal frames or beams) as shown in [Figure 69](#). Do not expose the drive to bending forces from the structure. The installation must be vertical (as defined in [10.8.4 Mounting Orientation](#)), and the structure must be non-flammable.



**Figure 69: Mounting on Structures**

The drives are designed with a closed air-guiding channel, which secures the correct airflow for cooling. It must remain in the drive to ensure proper cooling. If defective, a new air-guide plate is needed. For more information, see [12.5 Ordering Self-service Parts](#).

IP21/UL Type 1 rated frames FK09–FK12 can also be mounted free-standing on floors. Floor-mounting FK09–FK10 frames requires a dedicated pedestal. Frames FK11–FK12 are shipped with a pedestal. For more information, refer to the installation guides for pedestal kits.

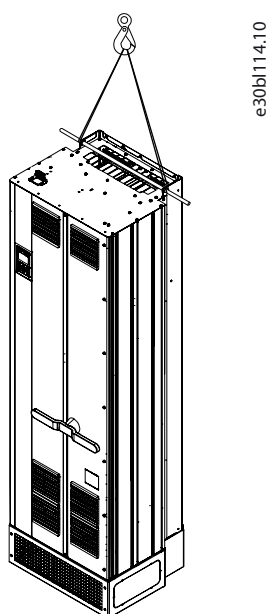

Figure 70: Mounting on a Pedestal

### 10.8.4 Mounting Orientation

The drive can be mounted in different directions, depending on the frame. Mounting in directions other than vertical affects drive performance. See [Table 58](#) and [Table 59](#) for more information on the effects of mounting direction on drive performance.

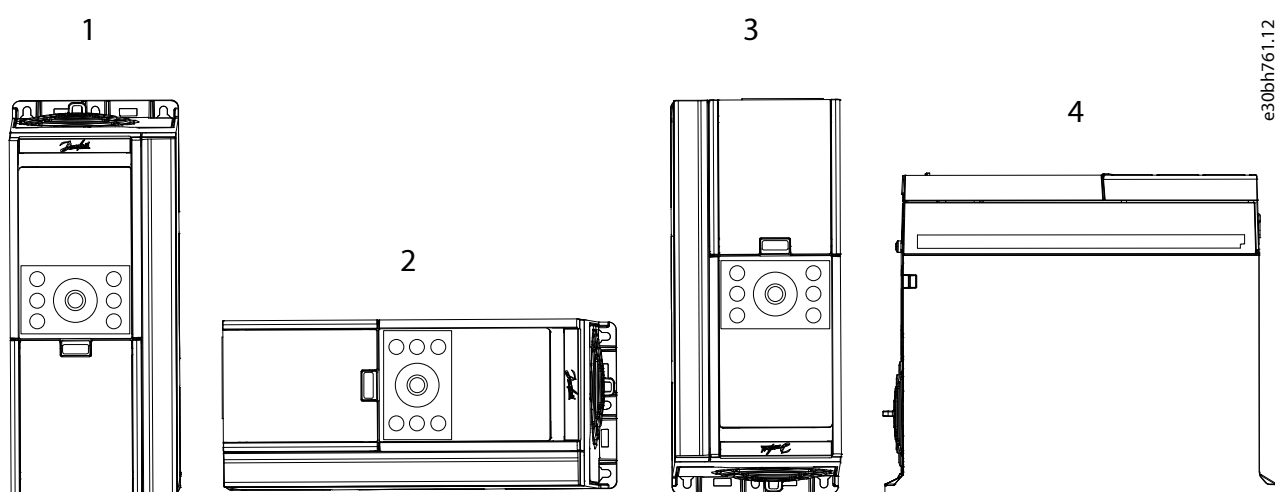

Figure 71: Mounting Orientations for Drives

Table 58: Mounting Orientations and Effects on Performance for IP20/UL Open Type Drives (FA02–FA12)

Orientation	Allowed for frame	Effects on performance
1 – Vertical installation	FA02–FA12	None
2 – Horizontal installation (rotated 90°)	FA02–FA08	<ul style="list-style-type: none"> <li>Limited robustness to vibration and shock</li> <li>Side-by-side mounting not possible</li> </ul>
	FA09–FA12	None

**Table 58: Mounting Orientations and Effects on Performance for IP20/UL Open Type Drives (FA02–FA12)** (continued)

Orientation	Allowed for frame	Effects on performance
3 – Turned upside down	No	–
4 – Mounted on back side	FA02–FA08	<ul style="list-style-type: none"> <li>• Protection reduced to IP00</li> <li>• Limited robustness to vibration and shock</li> <li>• Side-by-side mounting not possible</li> </ul>

**Table 59: Mounting Orientations and Effects on Performance for IP21/UL Type 1 and IP54/IP55/UL Type 12 Drives (FK06–FK12/FB09–FB12)**

Orientation	Allowed for frames	Effects on performance
1 – Vertical installation	FK06–FK12, FB09–FB12	None
2 – Horizontal installation (rotated 90°)	No	–
3 – Turned upside down	No	–
4 – Mounted on back side	FK06–FK08	<ul style="list-style-type: none"> <li>• Complies only to IP20/UL Open Type</li> <li>• Not protected against dripping water</li> <li>• Limited robustness to vibration and shock</li> <li>• Side-by-side mounting not possible</li> </ul>

### 10.8.5 Recommended Fasteners

Check the recommended sizes of screws, bolts, or studs for mounting the drive in the following tables.

**Table 60: Recommended Screws, Bolts, and Studs for IP20/UL Open Type Frames**

Frame	Drive weight [kg (lb)]	Screw/Bolt/Stud size
FA02	4.7 (10.4)	4 x M5 (3/16") <sup>(1)</sup>
FA03	5.7 (12.6)	4 x M5 (3/16") <sup>(1)</sup>
FA04	11.6 (25.6)	4 x M6 (3/16")
FA05	14.1 (31.1)	4 x M6 (3/16")
FA06	26 (57)	4 x M8 (5/16")
FA07	38 (84)	4 x M8 (5/16")
FA08	55 (121)	4 x M8 (5/16")
FA09	81 (179)	4 x M10 (3/8")
FA10	127 (280)	4 x M10 (3/8")
FA11	225 (496)	6 x M12 (1/2")
FA12	298 (657)	6 x M12 (1/2")

1) If the installation site is not exposed to vibration or shock, frames FA02-FA03 can be mounted with 3 screws. For more information, see [10.8.6.2 Drilling Patterns for Wall-mounted Frames \(FA02–FA12\)](#).

**Table 61: Recommended Screws, Bolts, and Studs for IP21/UL Type 1 Frames**

Frame	Drive weight [kg (lb)]	Screw/Bolt/Stud size
FK06	28 (62)	4 x M8 (5/16")
FK07	38 (84)	4 x M8 (5/16")
FK08	62 (137)	4 x M8 (5/16")
FK09a	89 (196)	4 x M10 (3/8")
FK09c	107 (236)	4 x M10 (3/8")
FK10a	139 (306)	4 x M10 (3/8")
FK10c	178 (392)	2 x M10 (3/8") and 8 x M12 (1/2")
FK11	244 (538)	9 x M12 (1/2")
FK12	327 (721)	9 x M12 (1/2")

**Table 62: Recommended Screws, Bolts, and Studs for IP54/IP55/UL Type 12 Frames**

Frame	Drive weight [kg (lb)]	Screw/Bolt/Stud size
FB09a	89 (196)	4 x M10 (3/8")
FB09c	107 (236)	4 x M10 (3/8")
FB10a	139 (306)	4 x M10 (3/8")
FB10c	178 (392)	2 x M10 (3/8") and 8 x M12 (1/2")
FB11	244 (538)	9 x M12 (1/2")
FB12	327 (721)	9 x M12 (1/2")

## 10.8.6 Drilling Patterns

### 10.8.6.1 Overview

When preparing mounting holes for the installation, use the drilling patterns. The drilling pattern equals the mounting plate of the drive or the cable entry plate, depending on the frame.

The required space for cooling, EMC plates, and other extensions is not included in the drilling patterns.

For total space needed, see the drawings in chapter *Exterior and Terminal Dimensions*.

### 10.8.6.2 Drilling Patterns for Wall-mounted Frames (FA02–FA12)

#### NOTICE

- IP20/UL Open Type frames FA02–FA03 are normally mounted with 4 screws. If not exposed to vibration or shock, they can be mounted with 3 screws only.
- If mounted with 3 screws, use the upper middle screw position. Use the outer positions for the upper screws when mounted with 4 screws.

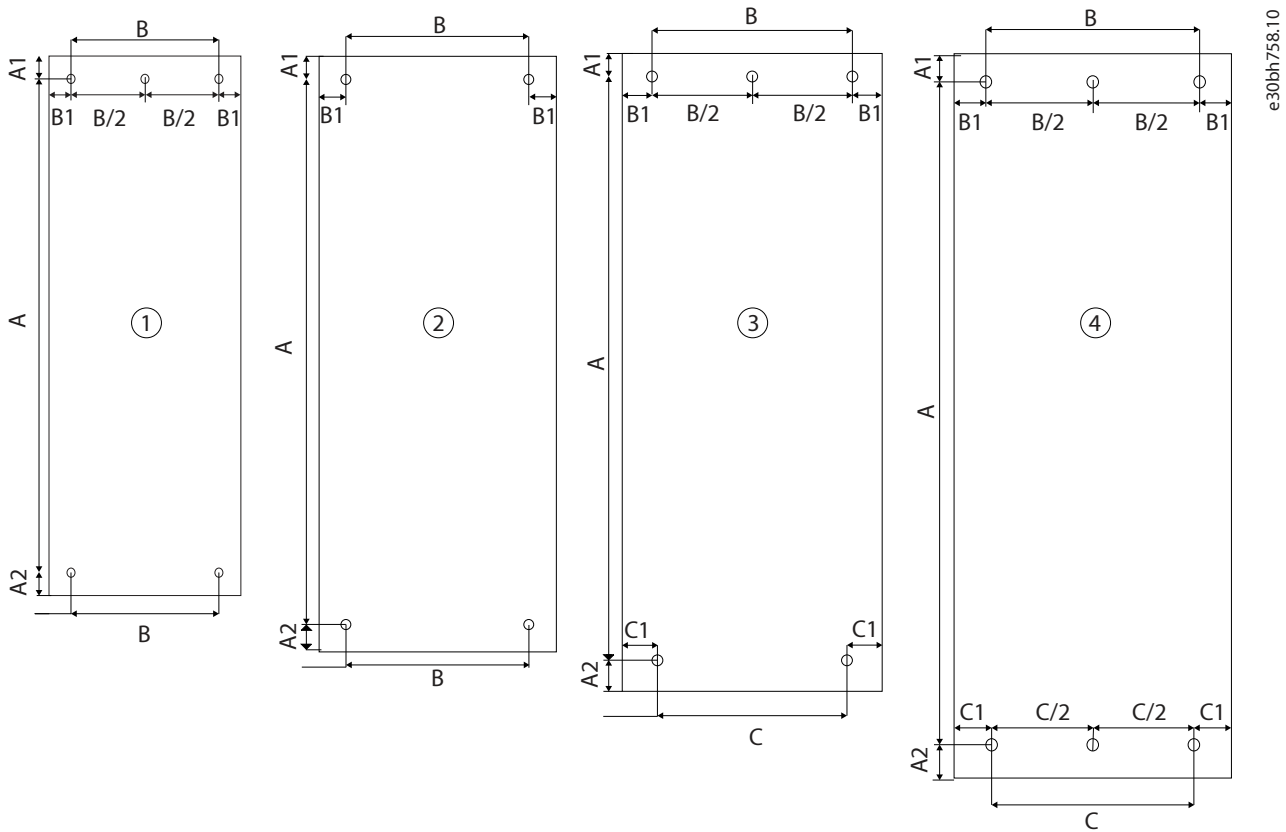

Figure 72: Drilling Patterns for Frames FA02–FA12

Table 63: Drilling Pattern Dimensions for Wall-mounted Frames (FA02–FA12)

Frame	Drilling pattern	A [mm (in)]	A1 [mm (in)]	A2 [mm (in)]	B [mm (in)]	B1 [mm (in)]	C [mm (in)]	C1 [mm (in)]
FA02	1	257 (10.1)	6.5 (0.26)	6.5 (0.26)	70 (2.8)	10 (0.4)	–	–
FA03	1	257 (10.1)	6.5 (0.26)	6.5 (0.26)	94 (3.7)	10 (0.4)	–	–
FA04	2	380 (15)	8 (0.32)	11 (0.43)	105 (4.1)	12.5 (0.5)	–	–
FA05	2	380 (15)	8 (0.32)	11 (0.43)	140 (5.5)	12.5 (0.5)	–	–
FA06	2	535 (21.1)	12 (0.47)	8 (0.32)	170 (6.7)	15 (0.6)	–	–
FA07	2	580 (22.1)	12 (0.47)	8 (0.32)	200 (7.9)	15 (0.6)	–	–
FA08	2	721 (28.4)	12 (0.47)	10 (0.39)	200 (7.9)	27.5 (1.08)	–	–
FA09	3	844 (33.2)	25 (0.98)	20 (0.79)	180 (7.1)	33.1 (1.3)	200 (7.9)	25 (0.98)
FA10	3	1051 (41.4)	25 (0.98)	20 (0.79)	280 (11.0)	33 (1.3)	271 (10.7)	39.5 (1.56)
FA11	4	1545 (60.8)	17.6 (0.69)	15 (0.59)	412 (16.2)	45.6 (1.8)	430 (16.9)	38.5 (1.52)
FA12	4	1545 (60.8)	17.6 (0.69)	15 (0.59)	508 (20.0)	45.6 (1.8)	526 (20.7)	38.5 (1.52)



### 10.8.6.3 Drilling Patterns for Wall-mounted Frames (FB09–FB10a)

**Table 64: Drilling Pattern Dimensions for Wall-mounted Frames (FB09–FB10a)**

Frame	Drilling pattern	A [mm (in)]	A1 [mm (in)]	A2 [mm (in)]	B [mm (in)]	B1 [mm (in)]	C [mm (in)]	C1 [mm (in)]
FB09a	3	944 (37.2)	25 (0.98)	20 (0.79)	180 (7.1)	33.1 (1.3)	200 (7.9)	63.5 (2.5)
FB09c	3	1380 (54.3)	25 (0.98)	18.7 (0.74)	180 (7.1)	33.1 (1.3)	200 (7.9)	62.5 (2.5)
FB10a	3	1176 (46.3)	25 (0.98)	24.5 (0.96)	280 (11)	33.1 (1.3)	271 (10.7)	74.5 (2.93)

### 10.8.6.4 Drilling Patterns for Wall-mounted Frames (FK06–FK09, FK10a)

**Table 65: Drilling Pattern Dimensions for Wall-mounted Frames (FK06–FK09, FK10a)**

Frame	Drilling pattern	A [mm (in)]	A1 [mm (in)]	A2 [mm (in)]	B [mm (in)]	B1 [mm (in)]	C [mm (in)]	C1 [mm (in)]
FK06	2	535 (21.1)	12 (0.47)	8 (0.32)	170 (6.69)	19.5 (0.77)	–	–
FK07	2	580 (22.8)	12 (0.47)	8 (0.32)	200 (7.9)	19.5 (0.77)	–	–
FK08	2	721 (28.4)	12 (0.47)	10 (0.39)	200 (7.9)	33.5 (1.3)	–	–
FK09a	3	944 (37.2)	25 (0.98)	20 (0.79)	180 (7.1)	33.1 (1.3)	200 (7.9)	63.5 (2.5)
FK09c	3	1380 (54.3)	25 (0.98)	18.7 (0.74)	180 (7.1)	33.1 (1.3)	200 (7.9)	62.5 (2.5)
FK10a	3	1176 (46.3)	25 (0.98)	24.5 (0.96)	280 (11)	33.1 (1.3)	271 (10.7)	74.5 (2.93)

### 10.8.6.5 Drilling Patterns for Free-standing Frames (FK10c/FB10c, FK11/FB11, FK12/FB12)

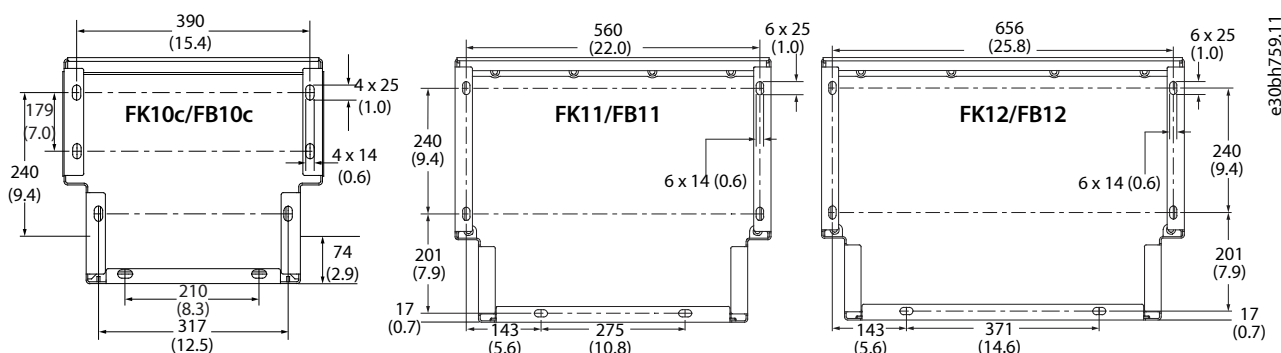
**Figure 73: Drilling Patterns for Cable Openings in the Cable Entry Plate (FK10c/FB10c, FK11/FB11, FK12/FB12)**

## 10.8.7 Placement of the Drive in the Installation

Before mounting the drive, prepare the mounting location with appropriate fasteners so the drive can be positioned safely. Make sure that there is enough space to handle the drive safely during installation. The center of gravity for each frame is shown in the drawings in chapter *Exterior and Terminal Dimensions*.

Frames FA02–FA05 can be lifted and mounted without lifting equipment by 1 or 2 persons. Check the weight on the packaging of the drive. All screws can be fitted before mounting the drive on the screws and tightening them.

When installing frames Fx06–Fx10, lift the drive using the lifting eyes as shown in [Figure 74](#). Ensure proper space for access of lifting tools at installation.

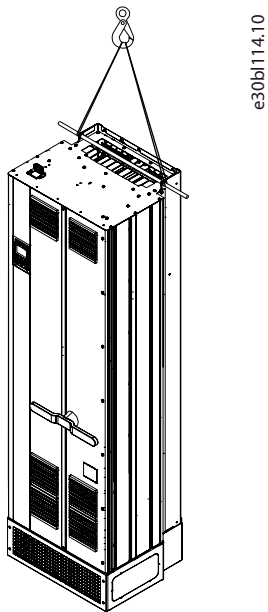

Figure 74: Lifting the Fx06–Fx10 Frames Using Lifting Eyes

Lower screws or bolts can be mounted before installation. Position the drive on the lower bolts, and mount the upper screws or bolts.

When installing frames Fx11–Fx12, lift the drive using the lifting eyes (see [Figure 75](#)). To avoid bending the lifting holes, use a bar.

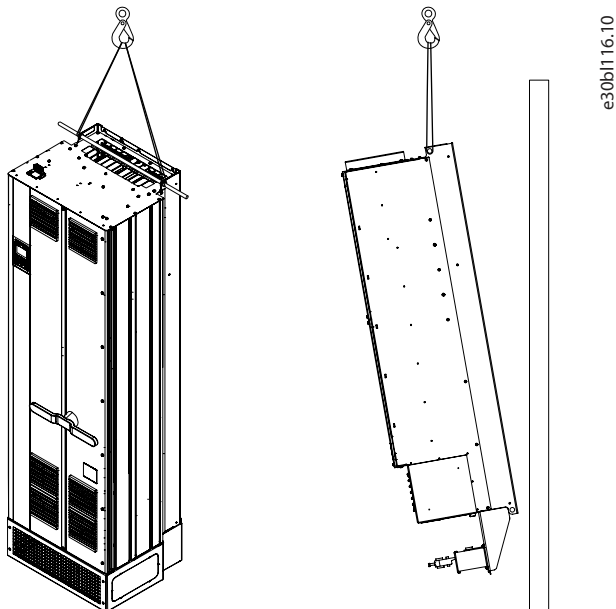

Figure 75: Lifting the Fx11–Fx12 Frames Using a Lifting Bar

Mount bolts for the lower part of the drive before mounting. Upper bolts are mounted when the drive is placed on the lower bolts, and placed towards the wall. If mounted on a pedestal, fix the pedestal to the floor before placing the drive on the pedestal.

## 10.8.8 Cooling

### 10.8.8.1 Overview of Cooling

All frequency converters are cooled by forced airflow. Frames Fx09–Fx12 have back-channel cooling, which makes installation of the drive more flexible.

For all installations, the temperature of the installation site must be kept within the specified operating temperature range by ventilation or cooling. The quality of the cooling air must comply with the environmental conditions as defined in the technical specifications (dust, airborne particles, chemical substances).

For more information on power loss and required cooling airflow, see [8.6.1 Power Loss](#) and [8.6.2 Airflow and Noise Levels](#).

### 10.8.8.2 Forced Air Cooling

All drives are air-cooled by forced airflow. For proper cooling, it must be ensured that there is sufficient clearance above and below the drive.

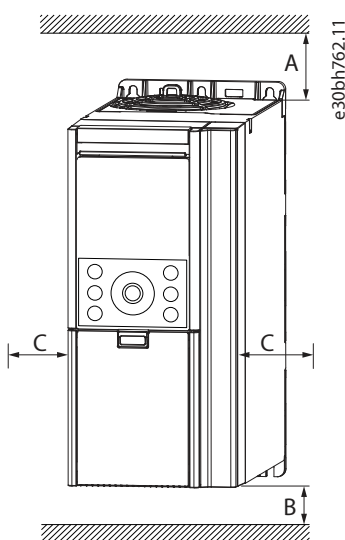

Figure 76: Clearance for Cooling

Table 66: Cooling Clearances for IP20/UL Open Type Frames

Frame	A [mm (in)]	B [mm (in)] <sup>(1)</sup>	C [mm (in)]
FA02	100 (3.9)	100 (3.9)	0 (0)
FA03	100 (3.9)	100 (3.9)	0 (0)
FA04	100 (3.9)	100 (3.9)	0 (0)
FA05	100 (3.9)	100 (3.9)	0 (0)
FA06	200 (7.9)	200 (7.9)	0 (0)
FA07	200 (7.9)	200 (7.9)	0 (0)
FA08	200 (7.9)	200 (7.9)	0 (0)
FA09	225 (8.9)	225 (8.9)	0 (0)
FA10	225 (8.9)	225 (8.9)	0 (0)

**Table 66: Cooling Clearances for IP20/UL Open Type Frames** (continued)

Frame	A [mm (in)]	B [mm (in)] <sup>(1)</sup>	C [mm (in)]
FA11	225 (8.9)	225 (8.9)	0 (0)
FA12	225 (8.9)	225 (8.9)	0 (0)

1) Distance does not include the EMC plate.

**Table 67: Cooling Clearances for IP21/UL Type 1 Frames**

Frame	A [mm (in)]	B [mm (in)] <sup>(1)</sup>	C [mm (in)]
FK06	200 (7.9)	200 (7.9)	0 (0)
FK07	200 (7.9)	200 (7.9)	0 (0)
FK08	200 (7.9)	200 (7.9)	0 (0)
FK09	225 (8.9)	225 (8.9)	–
FK10a	225 (8.9)	225 (8.9)	–
FK10c	225 (8.9)	–	–
FK11	225 (8.9)	–	0 (0)
FK12	225 (8.9)	–	0 (0)

1) Distance does not include the EMC plate.

**Table 68: Cooling Clearances for IP54/IP55/UL Type 12 Frames**

Frame	A [mm (in)]	B [mm (in)] <sup>(1)</sup>	C [mm (in)]
FB09	225 (8.9)	225 (8.9)	–
FB10a	225 (8.9)	225 (8.9)	–
FB10c	225 (8.9)	–	–
FB11	225 (8.9)	–	0 (0)
FB12	225 (8.9)	–	0 (0)

1) Distance does not include the EMC plate.

### 10.8.8.3 Back-channel Cooling

Back-channel cooling directs the heat out of the cabinet or room either by using closed air ducts or dedicated openings. Back-channel cooling applies to frames Fx09–Fx12.

A drive installed in a cabinet uses closed air ducts to minimize the heat dissipated inside the cabinet. The ducts direct external cooling air to the drive and out of the installation cabinet. The reduced heat dissipation minimizes the need for extra ventilation or cooling of the cabinet.

Cooling air can also be directed from outside a room to the drive heat sink. Heated air is vented to the outside of the drive. The top and bottom cooling openings of the drive are closed by covers, and cooling air is redirected out from the back of the drive.

See [Figure 77](#) for an example of cooling through air ducts and openings from the back of the drive.

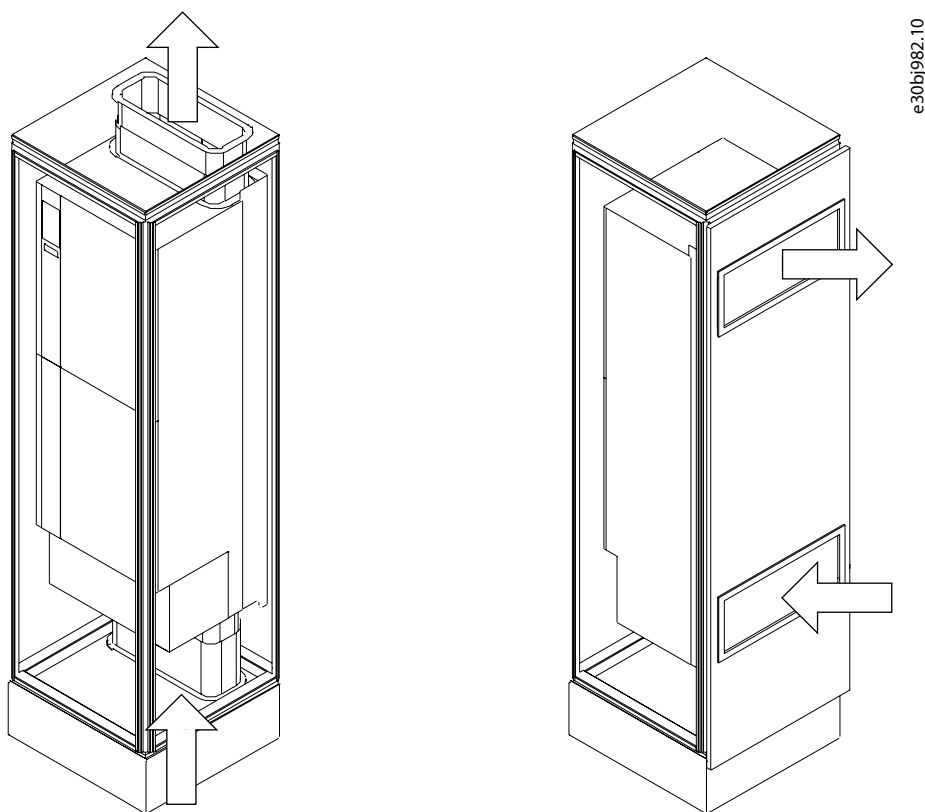

Figure 77: Examples of Back-channel Cooling Principles: Bottom-in, Top-out Cooling through Air Ducts (Left), Back-in, Back-out Cooling through Openings in the Back of the Drive (Right)

Back-channel cooling kits are available for IP20/UL Open Type frames (FA09–FA12). The kits make it easier to install drives in standard industrial frames such as Rittal. Back-channel cooling kits are also available for IP21/UL Type 1 frames (FK09–FK12) and IP54/IP55/UL Type 12 frames (FB09–FB12).

For more information on available cooling kits, see [12.4 Ordering Options and Accessories](#).

### 10.8.9 Recommended Space for Service Access

To ensure access to the drive for service and maintenance, it is recommended to reserve sufficient space around the drive.

The general recommendations include:

- Enough space in the front of the drive for removing covers, and access to the control board and installed options from the front.
- Enough space above the drive to access and remove fans for cleaning or service.
- Enough space below the drive to access the cooling channel entry to clean and remove pluggable connectors (FA02–FA05), and to mount EMC plates (FA02–FA12).

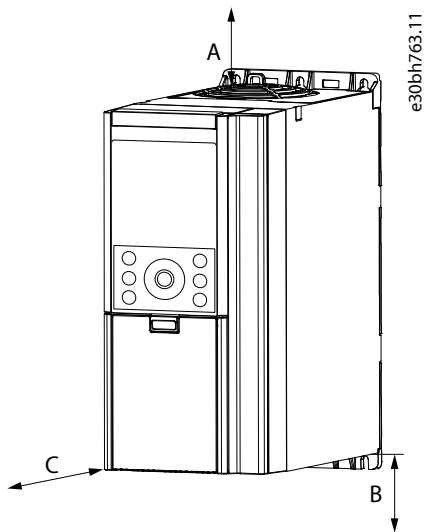

Figure 78: Recommended Clearance for Service Access

Table 69: Clearances for Service Access

Frame	Recommended space for access		
	Above (A) [mm (in)]	Below (B) [mm (in)]	Front (C) [mm (in)]
FA02	200 (7.9) <sup>(2)</sup>	200 (7.9) <sup>(2)</sup>	100 (3.9)
FA03	200 (7.9) <sup>(2)</sup>	200 (7.9) <sup>(2)</sup>	100 (3.9)
FA04	200 (7.9) <sup>(2)</sup>	200 (7.9) <sup>(2)</sup>	100 (3.9)
FA05	200 (7.9) <sup>(2)</sup>	200 (7.9) <sup>(2)</sup>	100 (3.9)
Fx06	200 (7.9)	200 (7.9)	400 (15.7) <sup>(3)</sup>
Fx07	200 (7.9)	200 (7.9)	400 (15.7) <sup>(3)</sup>
Fx08	250 (9.8)	300 (11.8)	400 (15.7) <sup>(3)</sup>
Fx09	225 (8.8)	225 (8.8)	400 (15.7) <sup>(4)</sup>
Fx10	225 (8.8)	225 (8.8)	600 (23.6) <sup>(4)</sup>
Fx11	225 (8.8)	225 (8.8)	800 (31.5) <sup>(4)</sup>
Fx12	225 (8.8)	225 (8.8)	800 (31.5) <sup>(4)</sup>

1) When referring to the entire series instead of a specific variant, Fx is used. For example, when describing FA02 and FK02 as a series, Fx02 is used.

2) Sufficient space to the cooling duct, exceeding the need for cooling. Alternatively, unplug the drive, and remove it from the installation for service.

3) Clearance needed for removing the cover.

4) Clearance needed for opening the door.

# 11 Electrical Installation Considerations

## 11.1 Wiring Diagram

This chapter gives a brief overview of the typical connections of a drive. See [Figure 79](#) for a principle diagram of the drive. The drive is built around a power unit, a control unit, and optional I/O options. The exact configuration depends on the drive model.

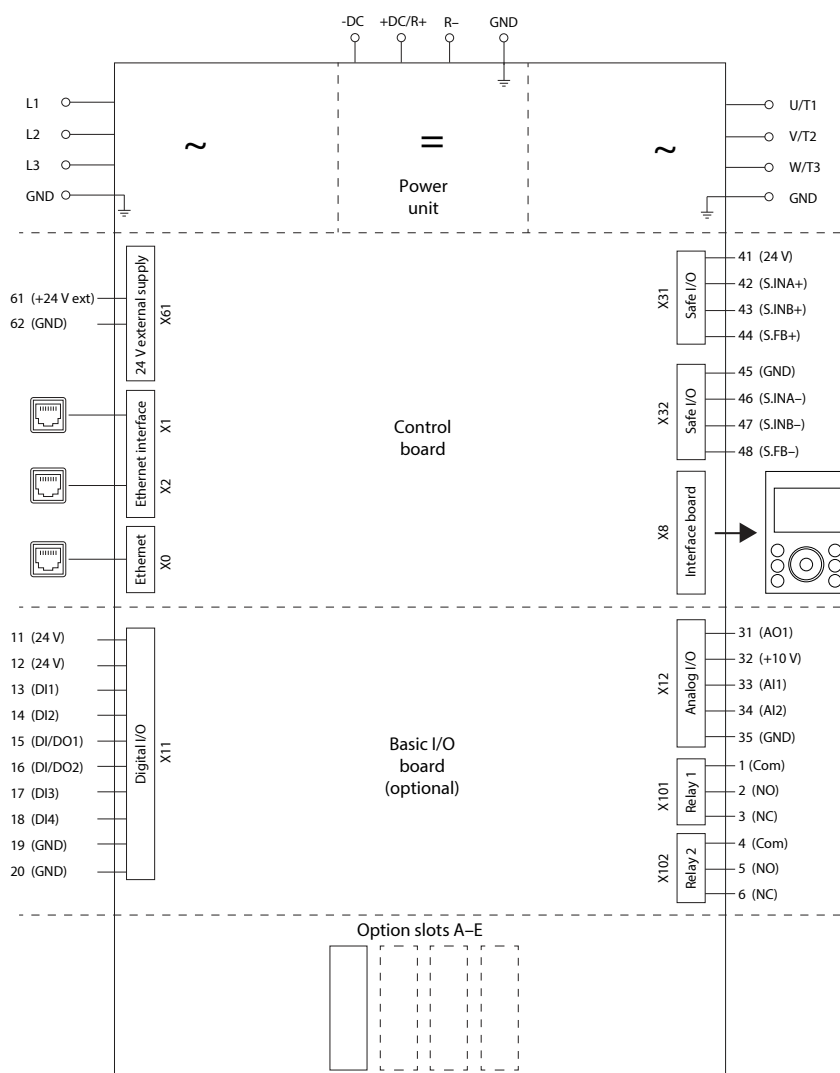

e30bk387.11

Figure 79: Wiring Diagram for Frequency Converters with an Ethernet-based Control Board

## 11.2 Grid Type and Protection

### 11.2.1 Grid Types

The drive can operate in different network types with rated network supply voltage:

- TN-S, TN-C, TN-C-S, TT (grounded delta)
- IT (ungrounded delta)

For detailed information about the parameters related to grid types, refer to the application guide.

### 11.2.2 Currents on Protective Earth and Potential Equalization/Leakage Currents

A properly dimensioned protective earth (PE) setup is essential for the safety of the drive system protecting against electric shock. The PE connections of the drive installation ensure that the drive system remains safe preventing that single fault currents generate hazardous voltages on accessible conductive parts, such as conductive enclosure parts.

The drive must be installed according to the requirement for PE connection and supplementary protective bonding as specified in EN 60364-5-54:2011 cl. 543 and 544. For the automatic disconnection if there is a fault at the motor side, it must be ensured that the impedance of the PE connection between drive and motor is sufficiently low to ensure compliance to IEC/EN 60364-4-41:2017 cl. 411 or 415. The impedance must be verified by initial and periodic test according to IEC/EN 60364-4-41:2017.

Local requirements may also apply.

Designing the system according to IEC/EN 61800-5-1:2017 ensures the suitability for the connection of PE and protective bonding of accessible conductive parts according to EN 60364-5-54:2011. When the drive is used as a component inside specific applications, special requirements for the proper connection to the PE, for example those specified in EN 60204-1:2018 and IEC/EN 61439-1:2021, can apply.

In low-voltage networks currents can arise on the protective conductor (PE) and equipotential bonding conductors and structures connected to earth potential as an undesirable effect. Since there are different causes for these currents, it is beneficial to know them to avoid them.

A drive setup consists of a mains supply, the drive inverter, its cabling, and a motor with the load side. Due to the behavior of the active and passive components and the electrical setup of the installation, several phenomena may appear resulting in currents on the PE conductor.

- Inductive coupling due to asymmetry in mains cables and/or busbars can cause PE current at the mains frequency and its harmonics.
- Inductive coupling due to asymmetry in motor cables can cause PE current at the motor fundamental frequency.
- As part of the EMI filter DC link, capacitive decoupling to PE can cause PE currents at 150 Hz/180 Hz.
- Voltage distortion/harmonic content on the mains can typically cause PE currents in the 150 Hz–2000 Hz range.
- Common-mode currents due to motor cable capacitance from motor phases to PE typically result in PE currents at the switching frequency and harmonics typically above 2 kHz.

The PE current is made up of several contributions and depends on various system configurations:

- RFI filtering
- Motor cable length
- Motor cable shielding
- Drive power

### 11.2.3 PE Current Measurement

As the currents have different frequencies, it is not useful to measure an effective value only. Instead, it is required to perform a frequency/FFT measurement. This can be done by using an appropriate oscilloscope or specific measuring equipment. Just analyzing the effective value with a current clamp at the PE connection of the drive leads to insufficient and misleading results.



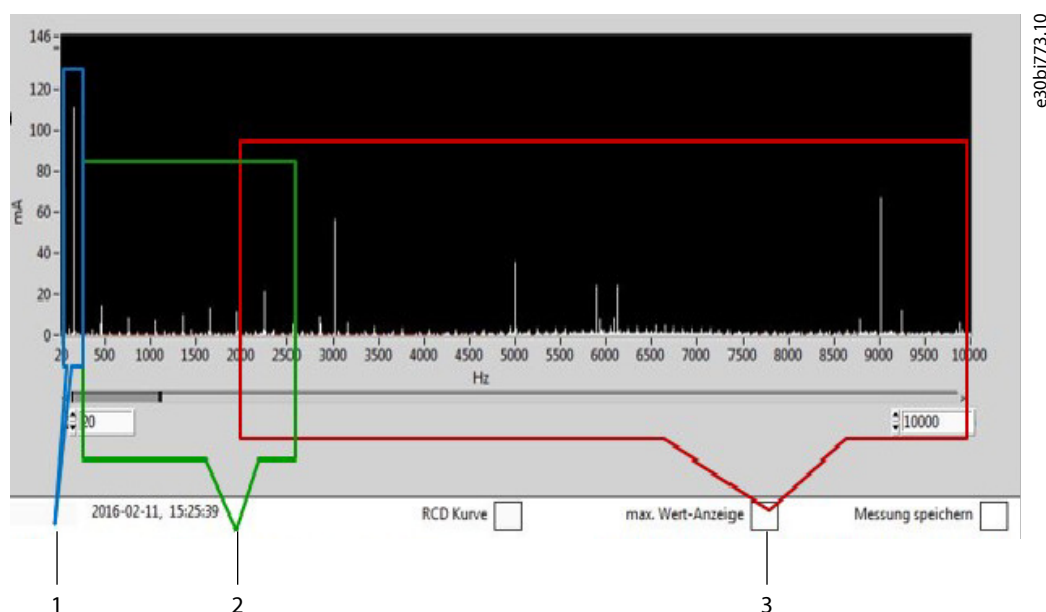

Figure 80: Example of FFT Measurement

- |                                                                                                                            |                                                                                                                                                                             |
|----------------------------------------------------------------------------------------------------------------------------|-----------------------------------------------------------------------------------------------------------------------------------------------------------------------------|
| <p>1 <math>f &lt; 50</math> Hz: Typical for inductive coupling in unsymmetrical cables and conductor.</p>                  | <p>2 <math>f = 150\text{--}2500</math> Hz: Typical harmonic components in grid.<br/><math>f = 150</math> Hz: Common-mode current typical due to rectifier with DC link.</p> |
| <p>3 <math>f &gt; 2</math> kHz: Typical common-mode current due to capacitive coupling between cable/motor and ground.</p> |                                                                                                                                                                             |

**⚠ WARNING**



**ELECTRICAL SHOCK HAZARD - LEAKAGE CURRENT HAZARD >3.5 MA**

Leakage currents exceed 3.5 mA. Failure to connect the drive properly to protective earth (PE) can result in death or serious injury.

- Ensure reinforced protective earthing conductor according to IEC 60364-5-54 cl. 543.7 or according to local safety regulations for high touch current equipment. The reinforced protective earthing of the drive can be done with:
  - a PE conductor with a cross-section of at least 10 mm<sup>2</sup> (8 AWG) Cu or 16 mm<sup>2</sup> (6 AWG) Al.
  - an extra PE conductor of the same cross-sectional area as the original PE conductor as specified by IEC 60364-5-54 with a minimum cross-sectional area of 2.5 mm<sup>2</sup> (14 AWG) (mechanically protected) or 4 mm<sup>2</sup> (12 AWG) (not mechanically protected).
  - a PE conductor completely enclosed with an enclosure or otherwise protected throughout its length against mechanical damage.
  - a PE conductor part of a multi-conductor power cable with a minimum PE conductor cross-section of 2.5 mm<sup>2</sup> (14 AWG) (permanently connected or pluggable by an industrial connector. The multi-conductor power cable shall be installed with an appropriate strain relief).
- NOTE: In IEC/EN 60364-5-54 cl. 543.7 and some application standards (for example IEC/EN 60204-1), the limit for requiring reinforced protective earthing conductor is 10 mA leakage current.

**WARNING****LEAKAGE CURRENT HAZARD**

Leakage currents can exceed 5%. Failure to ground the drive properly can result in death or serious injury.

- Ensure that the minimum size of the ground conductor complies with the local safety regulations for high touch current equipment.

Protective earth (PE) and equipotential bonding are usually connected to one another so that equipotential bonding currents are also distributed over the entire PE system.

PE currents and their impact on the system can be avoided or reduced by using short motor cables, symmetrical cables (especially for current ratings > 50 A), or shielded cables with low capacitance between conductors and PE.

### 11.2.4 Residual Current Device (RCD) Protection

Residual current devices (RCD) may be used to provide additional protection against electrical shock and fire hazards due to fault currents because of insulation faults or high leakage currents. Additional consideration is needed when RCDs are used in front of the drive. RCDs must always be installed according to local regulations.

**WARNING****ELECTRICAL SHOCK AND FIRE HAZARD – RCD COMPLIANCE**

Failure to use a Type B residual current-operated protective device (RCD) can lead to the RCD not providing the intended protection and therefore can result in death, fire, or other serious hazard.

- When an RCD is used for protection against electrical shock or against fire, only a Type B device is allowed on the supply side.

RCD/RCM devices cannot differentiate between operating and fault currents, and their function can be impaired. RCDs can be triggered even though there is no insulation fault in the installation.

The current measured by an RCD/RCM on mains phases might differ from the measured PE current. This is due to magnetic coupled PE current not being present on mains phases.

The frequency characteristic of Type B RCDs is not completely standardized, and vendor-specific differences are to be expected in the upper frequency range. Consult the documentation of the RCD in question for more information.

### 11.2.5 Isolation Monitoring Devices

When operating on an IT grid, isolation monitoring devices can be used for observing the integrity of the isolation in the supply cabling, motor, motor cabling, and the drive.

The typical applications are:

- Preventive detection of degradation of the isolation system.
- Ground fault detection on IT mains.

The isolation monitor is a key component in an IT mains installation. It allows preventive maintenance and warns whenever a ground fault occurs. Several types of isolation monitors exist with different operation principles, for example, DC-voltage injection, DC voltage with alternating polarity injection and current injection. Not all isolation monitors are compatible with drive systems due to capacitances to ground and drives producing common-mode voltages. It is essential that the isolation monitor used in a drive system installation is compatible with drives.

## 11.3 EMC-compliant Installation Guidelines

### 11.3.1 EMC-compliant Installation Guidelines

This chapter gives a general introduction to proper EMC-compliant installation practice. To obtain an EMC-compliant installation, follow the instructions provided in the installation and safety guides supplied with the drive.

#### NOTICE

According to the EMC Directive, a system is defined as a combination of several types of equipment, finished products, and/or components combined, designed and/or put together by the same person (system manufacturer) intended to be placed on the market for distribution as a single functional unit for an end user and intended to be installed and operated together to perform a specific task.

The EMC directive applies to products/systems and installations, but in case the installation is built up of CE-marked products/systems, the installation can also be considered compliant with the EMC directive. Installations are not CE-marked.

According to the EMC Directive, as a manufacturer of products/systems is responsible for obtaining the essential requirements of the EMC directive and attaching the CE mark. For systems involving load sharing and other DC terminals, can only ensure compliance with the EMC Directive when combinations of products are connected as described in the technical documentation.

If any third-party products are connected to the load share or other DC terminals on the AC drives, cannot guarantee that the EMC requirements are fulfilled.

If installed in residential environments, and not compliant to category C1, the drive may not provide adequate protection to radio reception in such locations. In such cases supplementary mitigation measures might be required, for example, the use of shielding or increasing the distance between affected products.

If not compliant to category C1 or C2, the drive must not be installed in a public low voltage network, which supplies residential premises. Radio frequency interference can be expected if used on such a network. Follow the instructions for installation given in the product-specific installation guide.

If the RFI filters of the drive are disabled, the drive fulfills category C4. In this case the drive is intended to be used in an installation powered by a supply which does not radiate, for example a dedicated transformer or generator, or low voltage underground lines.

If guidelines for installation are not followed carefully, radio frequency interference can be expected.

See [Figure 81](#) for an example on how to ensure a proper EMC-compliant installation.

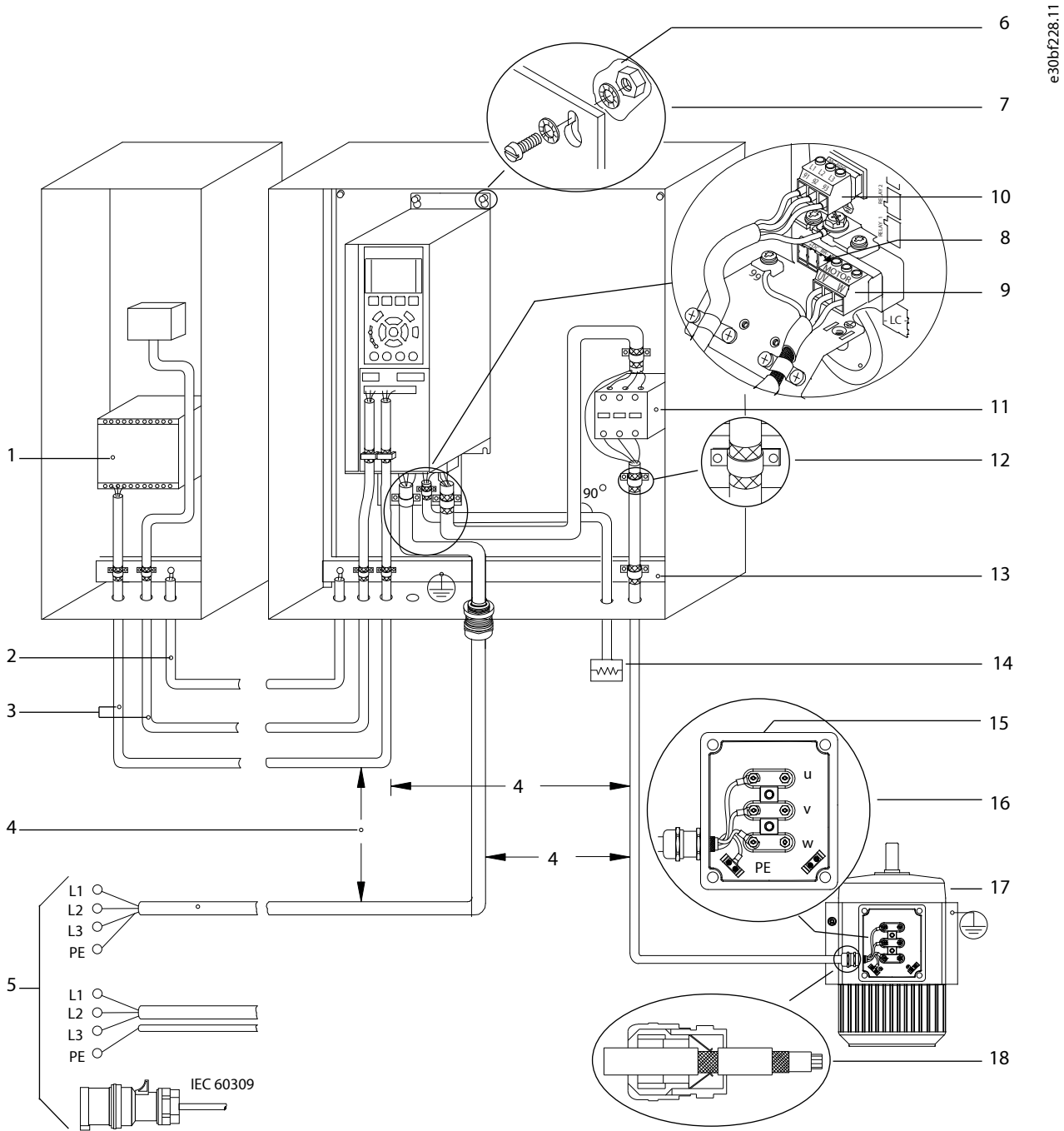

e30bf28.11

Figure 81: Example of Proper EMC Installation

1	Programmable logic controller (PLC)	2	Minimum 16 mm <sup>2</sup> (6 AWG) equalizing cable
3	Control cables	4	Minimum 200 mm (7.9 in) between control cables, motor cables, and mains cables
5	Mains supply options, see IEC/EN 61800-5-1	6	Bare (unpainted) surface
7	Star washers	8	Brake cable (shielded) – not shown, but same grounding principle applies as for motor cable
9	Motor cable (shielded)	10	Mains cable (unshielded)

11	Output contactor	12	Cable insulation stripped
13	Common ground busbar. Follow local and national requirements for cabinet grounding.	14	Brake resistor
15	Terminal box	16	Connection to motor
17	Motor	18	EMC cable gland

### 11.3.2 Power Cables and Grounding

Depending on the installation and the required EMC compliance level, using shielded cables is required for motor, brake, and DC connections. Alternatively, unshielded cables within a metal conduit can also be used.

If a shielded cable is used, it is important to connect the shield through a 360° connection. Connect the shield with the supplied clamps, and avoid pigtails, as they limit the shielding functionality.

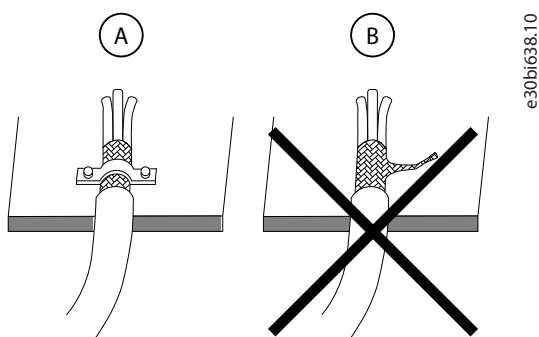

Figure 82: Installation of Cable Shield

#### NOTICE

##### SHIELDED CABLES

If shielded cables or metal conduits are not used, the unit and the installation do not meet regulatory limits.

If a non-shielded wire is used to connect a brake resistor, it is recommended to twist the wires to reduce the electric noise.

Ensure that the cables are as short as possible to reduce interference level from the entire system and minimize losses.

 **WARNING****ELECTRICAL SHOCK HAZARD - LEAKAGE CURRENT HAZARD >3.5 MA**

Leakage currents exceed 3.5 mA. Failure to connect the drive properly to protective earth (PE) can result in death or serious injury.

- Ensure reinforced protective earthing conductor according to IEC 60364-5-54 cl. 543.7 or according to local safety regulations for high touch current equipment. The reinforced protective earthing of the drive can be done with:
  - a PE conductor with a cross-section of at least 10 mm<sup>2</sup> (8 AWG) Cu or 16 mm<sup>2</sup> (6 AWG) Al.
  - an extra PE conductor of the same cross-sectional area as the original PE conductor as specified by IEC 60364-5-54 with a minimum cross-sectional area of 2.5 mm<sup>2</sup> (14 AWG) (mechanically protected) or 4 mm<sup>2</sup> (12 AWG) (not mechanically protected).
  - a PE conductor completely enclosed with an enclosure or otherwise protected throughout its length against mechanical damage.
  - a PE conductor part of a multi-conductor power cable with a minimum PE conductor cross-section of 2.5 mm<sup>2</sup> (14 AWG) (permanently connected or pluggable by an industrial connector. The multi-conductor power cable shall be installed with an appropriate strain relief).
- NOTE: In IEC/EN 60364-5-54 cl. 543.7 and some application standards (for example IEC/EN 60204-1), the limit for requiring reinforced protective earthing conductor is 10 mA leakage current.

Ground the drive according to applicable standards and directives. Use a dedicated ground wire for input power, motor power, and control wiring. Terminate individual ground wires separately, complying with the dimension requirements.

Follow motor manufacturers wiring requirements when connecting to the motors.

Keep the grounding wire as short as possible. The minimum cable cross-section for the ground wires is 10 mm<sup>2</sup> (7 AWG). Alternatively, it is possible to use 2 rated ground wires terminated separately. Do not ground drives to each other in a daisy-chain fashion (see [Figure 83](#)).

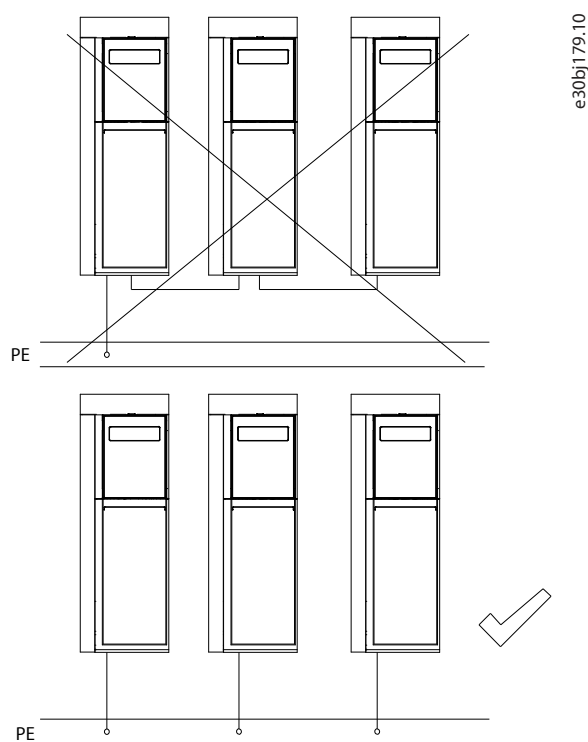

Figure 83: Grounding Principle

### 11.3.3 Control Cables

Use shielded cables for control wiring and avoid placing control wires next to power cables. Ideally, isolate the control cables from the power cables (mains, motor, brake, and DC) by routing them separately or keep a minimum distance of 200 mm (7.9 in). For optional shielding, both ends of the shielded control cables must have the shield connected.

Keep 24 V signal cables apart from 110 V or 230 V signals from relays, for example.

When the drive is connected to a thermistor, ensure that the wiring is shielded and reinforced/double isolated. A 24 V DC supply voltage is recommended.

For communication purpose and command/control lines, follow the particular protocol standard.

## 11.4 Motor Installation Considerations

### 11.4.1 Motor Installation Considerations

When selecting an AC drive, consider the following aspects:

- **Torque limits:** When an AC drive controls a motor, torque limits can be set for that motor. Selecting a frequency converter with an apparent power rating that matches the rated current or power of the motor ensures that the required load can be driven reliably. However, an extra reserve is necessary to enable smooth acceleration of the load and also cater for occasional peak loads.
- **Current ratings** of the drive and the motor. Power rating is only a rough guide.
- **Correct operating voltage.**
- Ensure that the motor withstands the **maximum peak voltage** on the motor terminals.
- **Required speed range:** Operation above the nominal motor supply frequency (50 Hz or 60 Hz) is possible only at reduced power. Operation at low frequency and high torque can cause the motor to overheat due to lack of cooling.
- **Derating:** Synchronous motors require derating, typically by 2–3 times, because the power factor, and hence the current, can be high at low frequency.

- **Overload performance:** The drive limits current to 160% or 200% of full current quickly. A standard, fixed-speed motor tolerates these overloads.
- **Stopping the motor:** If it is necessary to stop the motor quickly, using a brake resistor should be considered (select braking terminals on iC7-Automation) to absorb the energy.
- The **direction of rotation** when connected to the frequency converter's output terminals U-V-W follows the specification from NEMA MG1 and IEC 60034-8. Ensure correct direction of rotation in the end application to avoid a potentially hazardous situation. If only 1 direction of rotation is required, it is recommended to parameterize the drive to operate in the relevant direction only.

**WARNING**



**INDUCED VOLTAGE**

Induced voltage from output motor cables that run together or near other power cables can charge equipment capacitors, even with the mains power turned off and locked out. Failure to run output motor cables separately, or to use shielded cables, could result in death or serious injury.

- Install output motor cables in separate conduits or use shielded cables.

For the basics of protecting the motor insulation and bearings in AC drive systems, see [11.4.3 Motor Insulation](#) and [11.4.5 Bearing Currents](#).

### 11.4.2 Supported Motor Types

The iC7-Automation drives are compatible with:

- Asynchronous AC induction motors
- Synchronous permanent magnet motors

The drives are motor-independent, and can be connected to any brand of motor. For instructions on how to set up motors, refer to the relevant application guide.

For detailed information about the supported motor types, contact Danfoss.

### 11.4.3 Motor Insulation

Because of rapid switching and reflections in the cables, motors are subject to more voltage stress in the windings when fed by AC drives than with sinusoidal supply voltage.

Regardless of frequency, the AC drive output comprises pulses of approximately the drive DC-bus voltage with a short rise time. The pulse voltage can almost double at the motor terminals, depending on the attenuation and reflection properties of the motor cable and the terminals. This stresses the motor winding insulation and can cause it to break down, resulting in possible sparking.

Depending on voltage and cable length, a filter or reinforced insulation of the motor is required.

**Table 70: Recommended Motor Winding Protection**

Voltage (V)	Cable length (m [ft])	Protection
500–600	<150 (492)	Insulation and dU/dt filter
>600	<150 (492)	Insulation and dU/dt filter
>600	>150 (492)	Insulation

### 11.4.4 Parallel Motors

Many applications use more motors operating at the same speed. In some cases 1 drive controls multiple motors. When controlling multiple motors, the following conditions must be fulfilled:

- All motors must operate at the same speed.



- The design must accommodate the drive as a single point of failure.
- All motors must be started simultaneously by the drive. If an additional motor is connected during the operation of motors, oversizing the drive might be needed to avoid overcurrent faults.

### 11.4.5 Bearing Currents

AC drives can cause common mode voltages which induce voltages across motor bearings, leading to current flow through motor bearings. To protect against bearing currents, use either sine-wave filters, common-mode filters, or a combination of the two.

Two types of bearing current behaviors exist:

- Capacitive bearing behavior
- Resistive bearing behavior

The steep switching rate of the AC drive output voltage combined with the inherent common-mode voltage produced by the AC drive causes shaft voltage. Motor asymmetries, or the use of asymmetric motor cables especially in high-power applications where the motor current exceeds 100–200 A can also cause shaft voltage.

Bearing currents cannot be directly measured. Only rotor-to-ground can be measured to some extent. At motor sizes of 100 kW and up, it can be assumed that 10–30% of the measured common-mode current is bearing currents.

The bearing current type is a consequence of all elements in the installation, for example, the motor cable, drive, motor type and topology, shaft load and mechanical installation, and system grounding. The best way to control bearing currents is to combine common-mode filtering with a sine-wave filter, or to use an all-mode filter that significantly reduces bearing currents.

### 11.4.6 Motor Thermal Protection

During operation, the motor connected to the drive can be monitored to avoid overheating.

#### NOTICE

##### EXCESSIVE HEAT AND PROPERTY DAMAGE

Overcurrent can generate excessive heat within the drive. Failure to provide overcurrent protection can result in risk of fire and property damage.

- Additional protective devices such as short-circuit protection or motor thermal protection between drive and motor is required for applications with multiple motors.
- Input fusing is required to provide short-circuit and overcurrent protection. If fuses are not factory-supplied, the installer must provide them. Refer to the product-specific documentation for fuse specifications.

Depending on the criticality of overheating, different monitoring methods can be used:

- Built-in Electronic Thermal Motor monitoring
- External connected sensors (Pt, Ni, PTC, or KTY sensors)

For information on configuring the functionalities, refer to the application guide.

### 11.4.7 Electronic Thermal Relay Function

The electronic thermal relay (ETR) function protects the motor from thermal overload without connecting an external device by estimating the motor temperature based on present load and time.

The ETR function meets the relevant requirements of UL 61800-5-1, including the Thermal Memory Retention requirement, and ensures a class 20 protection level.

## NOTICE

### PROPERTY DAMAGE

Protection against motor overload is not included in the default setting. The ETR function provides class 20 motor overload protection. Failure to set the ETR function means that motor overload protection is not provided and property damage can occur if the motor overheats.

- Enable the ETR function. Refer to the application guide for more information.

## 11.4.8 External Connected Sensors

Monitoring can be done by using analog input or digital inputs on the I/O board or with functional extension options. The sensors must be either double isolated or have reinforced insulation between motor and drive control.

The analog input allows measurement of the temperature by using external sensors.

Using a digital input allows monitoring with a PTC sensor. The PTC must be connected from 24 V DC to the digital input.

## 11.5 Power Cable Considerations

### 11.5.1 Overview

When selecting power cables, consider the following:

- All wiring must comply with local and national regulations regarding cross-section and ambient temperature requirements.
- Drives are designed for use with 70 °C (158 °F) rated copper cables for frames up to Fx07. For Fx08–Fx12, a 90 °C (194 °F) rated copper cable is recommended. Unless otherwise stated, the ambient temperature of the drive matches the cable rating.
- Aluminum cables can be used from 35 mm<sup>2</sup> onwards. Proper connections must be secured by removing the oxide layer and applying joint compound.
- Cable lugs are required for the PE wire for frames FA02–FA05.

For details on power connector sizing, see [8.5 Power Connectors](#). The dimensions apply to both solid and stranded cables.

### 11.5.2 Torque Requirements

Connections must be tightened with the correct torque. See [Table 71](#), [Table 72](#), and [Table 73](#).

**Table 71: Torque Requirements for IP20/UL Open Type Frames**

Frame	Mains/Motor [Nm (in-lb)]	DC/Brake [Nm (in-lb)]	Ground connection [Nm (in-lb)]
FA02	0.7 (6.2)	0.7 (6.2)	2–3 (17.7–26.5)
FA03	0.7 (6.2)	0.7 (6.2)	2–3 (17.7–26.5)
FA04	1.2–1.5 (10.6–13.3)	1.2–1.5 (10.6–13.3)	2–3 (17.7–26.5)
FA05	2.0–2.5 (17.7–22.1)	2.0–2.5 (17.7–22.1)	2–3 (17.7–26.5)
FA06	14 (124)	14 (124)	2–3 (17.7–26.5)
FA07	14 (124)	14 (124)	2–3 (17.7–26.5)
FA08	20 (177)	14 (124)	2–3 (17.7–26.5)
FA09	19 (168)	19 (168)	9.6 (84)
FA10	19 (168)	19 (168)	19 (168)

**Table 71: Torque Requirements for IP20/UL Open Type Frames** (continued)

Frame	Mains/Motor [Nm (in-lb)]	DC/Brake [Nm (in-lb)]	Ground connection [Nm (in-lb)]
FA11	19 (168)/35 (310)	19 (168)	9.6 (84)/19 (168)
FA12	19 (168)/35 (310)	19 (168)	9.6 (84)/19 (168)

**Table 72: Torque Requirements for IP21/UL Type 1 Frames**

Frame	Mains/Motor [Nm (in-lb)]	DC/Brake [Nm (in-lb)]	Ground connection [Nm (in-lb)]
FK06	14 (124)	14 (124)	2–3 (17.7–26.5)
FK07	14 (124)	14 (124)	2–3 (17.7–26.5)
FK08	20 (177)	14 (124)	2–3 (17.7–26.5)
FK09 <sup>(1)</sup>	19 (168)	19 (168)	9.6 (84)
FK10 <sup>(2)</sup>	19 (168)	19 (168)	9.6 (84)
FK11	19 (168)/35 (310)	19 (168)	19 (168)
FK12	19 (168)/35 (310)	19 (168)	19 (168)

1) Applies to both FK09a and FK09c.

2) Applies to both FK10a and FK10c.

**Table 73: Torque Requirements for IP54/IP55/UL Type 12 Frames**

Frame	Mains/Motor [Nm (in-lb)]	DC/Brake [Nm (in-lb)]	Ground connection [Nm (in-lb)]
FB09	19 (168)	19 (168)	9.6 (84)
FB10	19 (168)	19 (168)	9.6 (84)
FB11	19 (168)/35 (310)	19 (168)	19 (168)
FB12	19 (168)/35 (310)	19 (168)	19 (168)

## 11.6 Control Cable Connections

### 11.6.1 Overview

Examples are shown with the control board and the optional basic I/O board. Standard I/O configurations are described with references to functionalities and connector numbering. For detailed information on I/O performance, see chapter *General Technical Data*. For detailed information on addressing the I/O, refer to the relevant application guide.

Standard setup is for 24 V logic (NPN logic). Operation with reverse logic is set in the software. For the locations of all I/O connections of the control board with the optional Basic I/O board, see [Figure 84](#).

The control connections in iC7-Automation drives come in 3 different colors, each color indicating a different characteristic of the connector.

Table 74: Control Connector Colors

Color	Functionality
Gray	Low voltage control (up to 24 V)
Black	Isolated I/O control that can support up to 250 V AC
Yellow	Functional safety

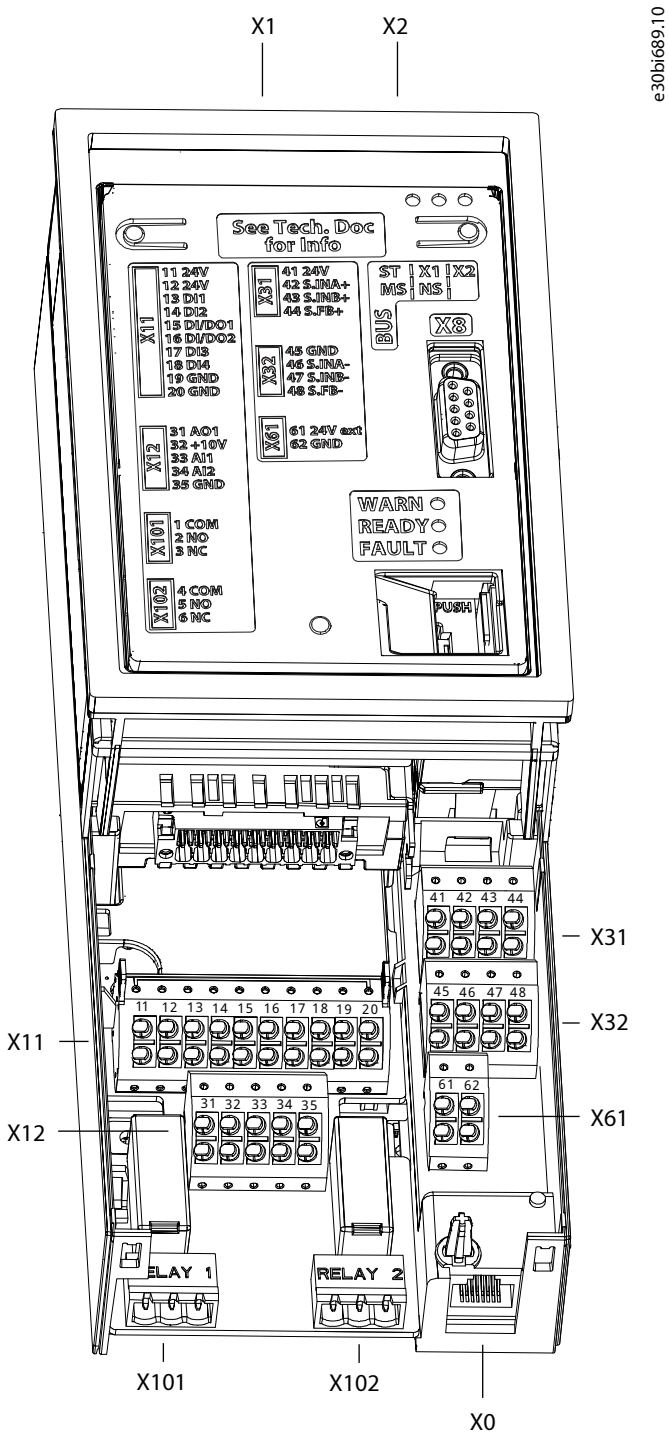

Figure 84: Location of Connections on the Control Board without Functional Extension Options

Table 75: I/O Connectors

Location	Connector name	Function	Color
Control board	X31	Functional safety connector	Yellow
	X32	Functional safety connector	Yellow
	X61	24 V external supply	Gray
Basic I/O (+BDDBA)	X11	Digital I/O connector	Gray
	X12	Analog I/O connector	Gray
	X101	Relay 1	Black
	X102	Relay 2	Black

The frequency converters can be equipped with 1–4 functional extension options. The number of options depends on the frame. For detailed information about the number of option slots in each frame, see [7.3.1 Overview](#).

### 11.6.2 Functional Safety I/Os (X31, X32)

The functional safety I/Os are configured for dual channel STO and STO feedback by default. To ensure correct installation, the I/O has 2 connectors that are not interchangeable.

If other functional safety functions than **STO, not upgradable (+BEF1)** have been selected in the drive configuration, the I/Os can be reconfigured. Use 24 V and GND from connectors X31/X32 when using the functional safety I/Os.

#### NOTICE

If **STO, not upgradable (+BEF1)** has been selected, the control board only supports hardwired STO, and cannot be reconfigured.

Table 76: Functional Safety I/O Functions

X31			X32		
Terminal	Terminal Name	Function	Terminal	Terminal Name	Function
41	24 V	+ 24 V DC Output	45	GND	0 V/GND
42	S.INA+	+ Safe Input Channel A	46	S.INA–	– Safe Input Channel A
43	S.INB+	+ Safe Input Channel B	47	S.INB–	– Safe Input Channel B
44	S.FB+	+ STO feedback	48	S.FB–	– STO Feedback

### 11.6.3 External 24 V Supply (X61)

The drive is fitted with a possibility to connect an external 24 V DC supply to the control board. If the mains supply is disconnected, the external 24 V supply allows continued operation of bus communication, built-in control programs, and control of I/Os.

Table 77: External 24 V (X61)

Terminal	Function
61	+24 V external supply
62	GND

### 11.6.4 Digital and Analog I/O (X11/X12)

Extra digital and analog I/Os are on the optional basic I/O board. See [Table 78](#) and [Table 79](#) for the configuration and supported functions of each I/O. For more information on the details of the functionalities, refer to the relevant application guide.

Connector X11 covers digital I/O, pulse I/O, and encoder support (HTL). The standard setting is NPN logic (24 V), but can be changed by a parameter to PNP (negative logic). For other encoder variants, a encoder/resolver option is required.

Connector X12 supports analog I/O and temperature sensors.

Table 78: I/O Connector X11: Digital and Pulse I/O

Terminal number	Terminal name <sup>(1)</sup>	Function
11	–	+24 V
12	–	+24 V
13	T13	Digital input 1
14	T14	Digital input 2
15	T15	Digital input/Digital output 1
16	T16	Digital input/Digital output 2 (also supports pulse output or pulse input)
17	T17	Digital input 3 (also supports encoder input A)
18	T18	Digital input 4 (also supports encoder input B)
19	–	GND
20	–	GND

1) The terminal name is used in application software to identify the terminal.

Table 79: I/O Connector X12: Analog I/O

Terminal number	Terminal name	Function
31	T31	Analog output (0–10 V, 0/4–20 mA)
32	–	+10 V reference
33	T33	Analog input 1 ( $\pm 10$ V, 0/4–20 mA)
34	T34	Analog input 2 ( $\pm 10$ V, 0/4–20 mA)
35	–	GND

**⚠ CAUTION**



**THERMISTOR INSULATION**

Risk of personal injury or equipment damage.

- To meet the PELV insulation requirements, use only thermistors with reinforced or double insulation.

### 11.6.5 Relay (X101/X102)

There are 2 relays on the basic I/O board. Each relay is galvanically isolated from other controls, and can operate voltages up to 250 V. Relevant installation requirements must be observed.

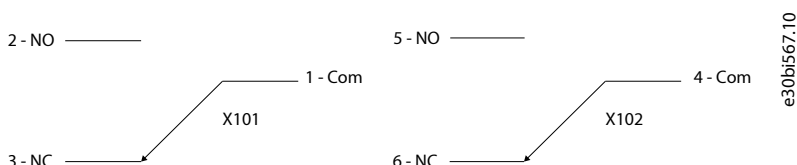

**Figure 85: Relay X101 and X102 Functionality**

**Table 80: Connector X101 and X102 Functions**

Terminal X101 (Terminal name: T2) <sup>(1)</sup>		Terminal X102 (Terminal name: T5) <sup>(1)</sup>	
Numbering	Function	Number	Function
1	Common	4	Common
2	Normally Open (NO)	5	Normally Open (NO)
3	Normally Closed (NC)	6	Normally Closed (NC)

<sup>1)</sup> The terminal name is used in application software to identify the terminal.

### 11.6.6 Communication Ports (X0, X1, X2)

#### 11.6.6.1 Overview

The locations of the communication ports depend on the frame. All connections are placed in the control board, but the wiring varies between different frames.

#### 11.6.6.2 Communication Port Locations in FA02-FA12 Frames

Port X0 is on the control board as shown in [Figure 86](#). The port is typically used to connect to a PC or similar equipment to configure the drive.

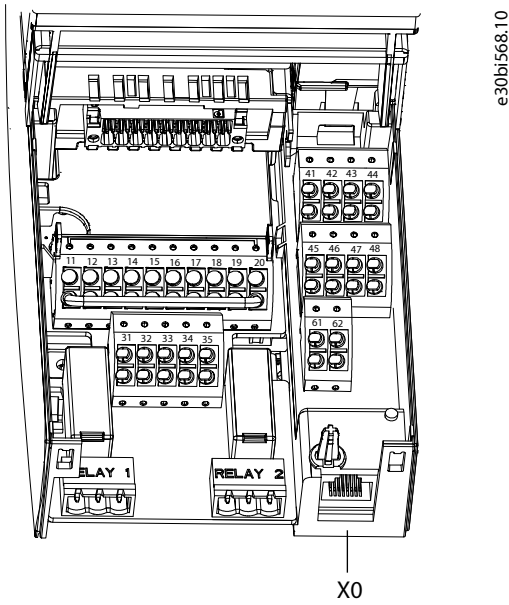

Figure 86: Location of the X0 Port on the Control Board

The communication interfaces X1 and X2 are on the top of the frequency converter as shown in [Figure 87](#). Industrial-grade RJ45 connectors are recommended for optimal connection.

A combined shield/fixing plate, the Fieldbus EMC plate, is available as an accessory to strengthen the mechanical fixation of the cables. For ordering details, see [12.5 Ordering Self-service Parts](#).

Figure 87: Location of the Communication Interface, X1/X2 in FA02-FA12 Frames (with the Optional EMC Plate)

### 11.6.6.3 Communication Port Locations in FB09–FB12/FK06–FK12 Frames

Port X0 is on the control board and communication ports X1 and X2 are located inside the frequency converter.

The position of the ports and the recommended wiring path are shown in [Figure 88](#) and [Figure 89](#).

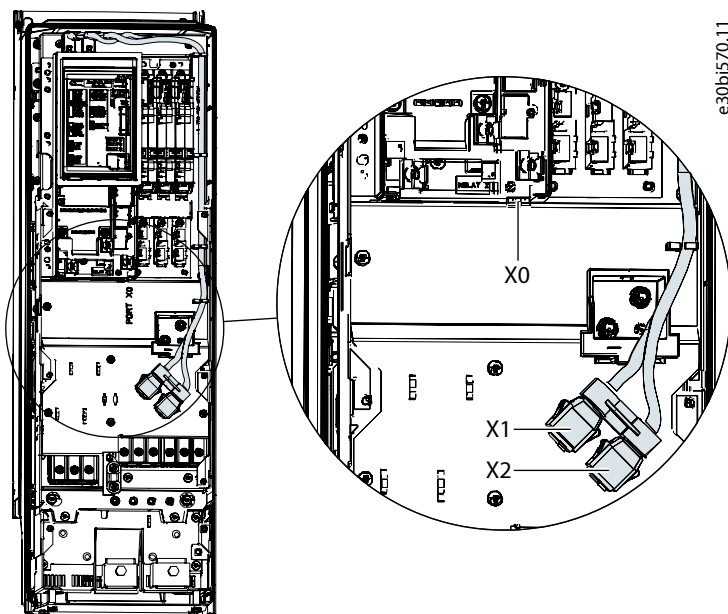

Figure 88: Communication Port X0, X1, and X2 Locations in FK06–FK08 Frames



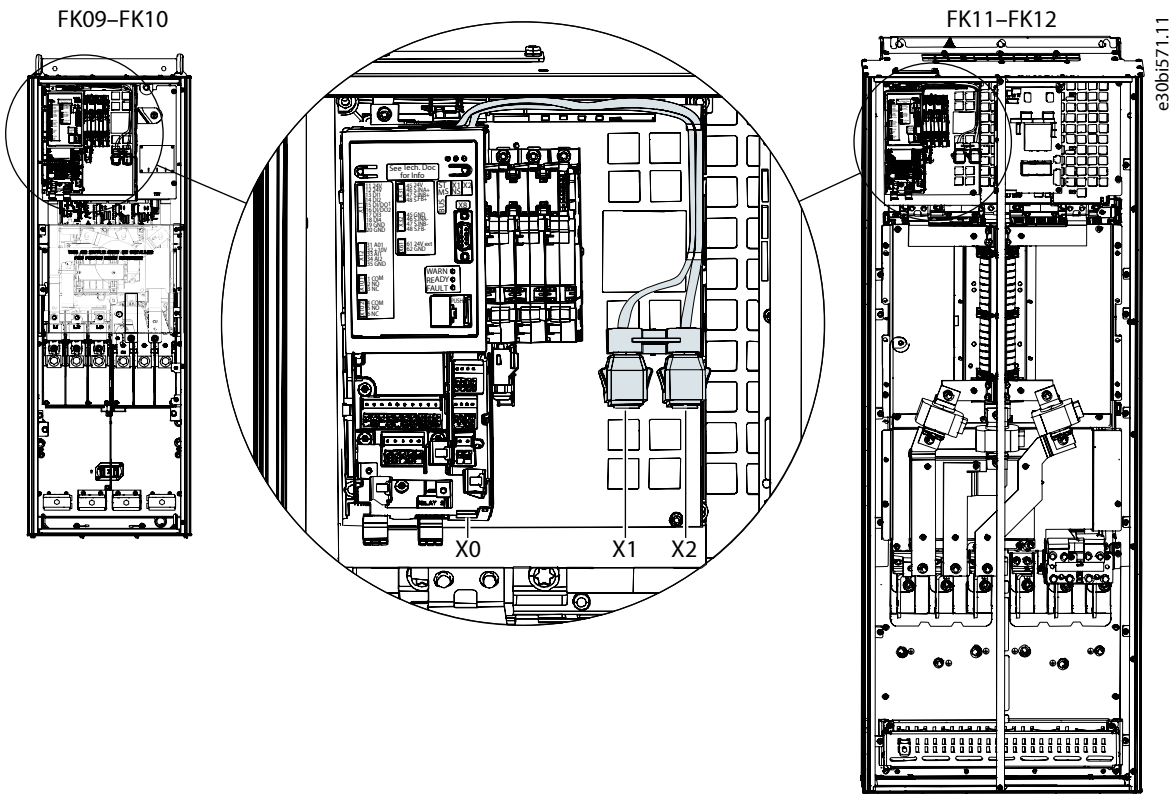

Figure 89: Communication Port X0, X1, and X2 Locations in FB09–FB12/FK09–FK12 Frames

### 11.6.7 Control Panel Connection (X8)

The control panel is typically mounted on the frequency converter. The control panel connects to the drive through the X8 connector on the interface board.

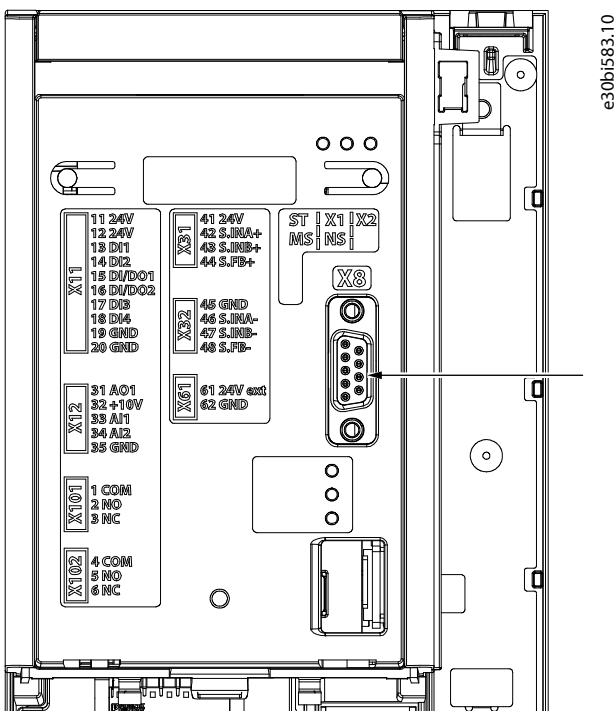

Figure 90: Location of the X8 Connector

It is also possible to mount the control panel externally with a control panel mounting kit. See [5.5.4 Control Panels](#) and the *iC7 Series Control Panels Mounting Kits Installation Guide* for more information on external mounting of control panels.

### 11.6.8 Functional Extension Options

Each drive can be fitted with 1–4 extra functional extension options, depending on the frame. The options are placed in option slots A–E. For more information on the detailed physical positions of the option slots, see [7.3.1 Overview](#).

As the connections to some option positions are established via other options, the following dependencies must be observed when designing the system:

- Option in slot B requires an option in slot A.
- Option in slot D requires an option in slot C.
- Option in slot E requires options in both slot C and slot D.

#### NOTICE

**WHEN ORDERING FRAMES FA02–FA05 WITH NO OPTIONS OR 1 OPTION ONLY, IT IS IMPORTANT TO CONSIDER CAREFULLY IF MORE THAN 1 OPTION IS NEEDED LATER.**

Adding more options increases the depth of the frequency converter.

- To secure upgradability, it is recommended to prepare for field upgradability in slot B (code +CBX0).

**Table 81: Number of Options Available for Different Frames**

Frame	No. of options	Slot A	Slot B	Slot C	Slot D	Slot E
IP20/UL Open Type	FA02a	1	O	–	–	–
	FA02b	2	O	O	–	–
	FA03a	1	O	–	–	–
	FA03b	3	O	O	O	–
	FA04a	1	O	–	–	–
	FA04b	3	O	O	O	–
	FA05a	1	O	–	–	–
	FA05b	4	O	O	O	O
	FA06–FA12	4	O	–	O	O
IP21/UL Type 1	FK06–FK12	4	O	–	O	O
IP54/IP55/UL Type 12	FB09–FB12	4	O	–	O	O

The position of the different slots and the recommendations for installing control cables for extra functional extension options fitted in the frequency converter are shown in [7.3.2 Option Slots](#).

For frames FA02b–FA05b, with options placed in both slot A and B, an extra EMC plate is needed to support the connected control cables.

When installing control cables, wires are connected to the connectors of the selected options, and the cable is fixed (shield connected) in the clamp connection.

For details on the control wiring for options, refer to *iC7 Series Functional Extension options Operating Guide*.

### 11.6.9 Control Cable Connections

For frames Fx06–Fx12, the control connectors are located as shown in [Figure 91](#). The drive has fastener joining points to secure the position of the wires.

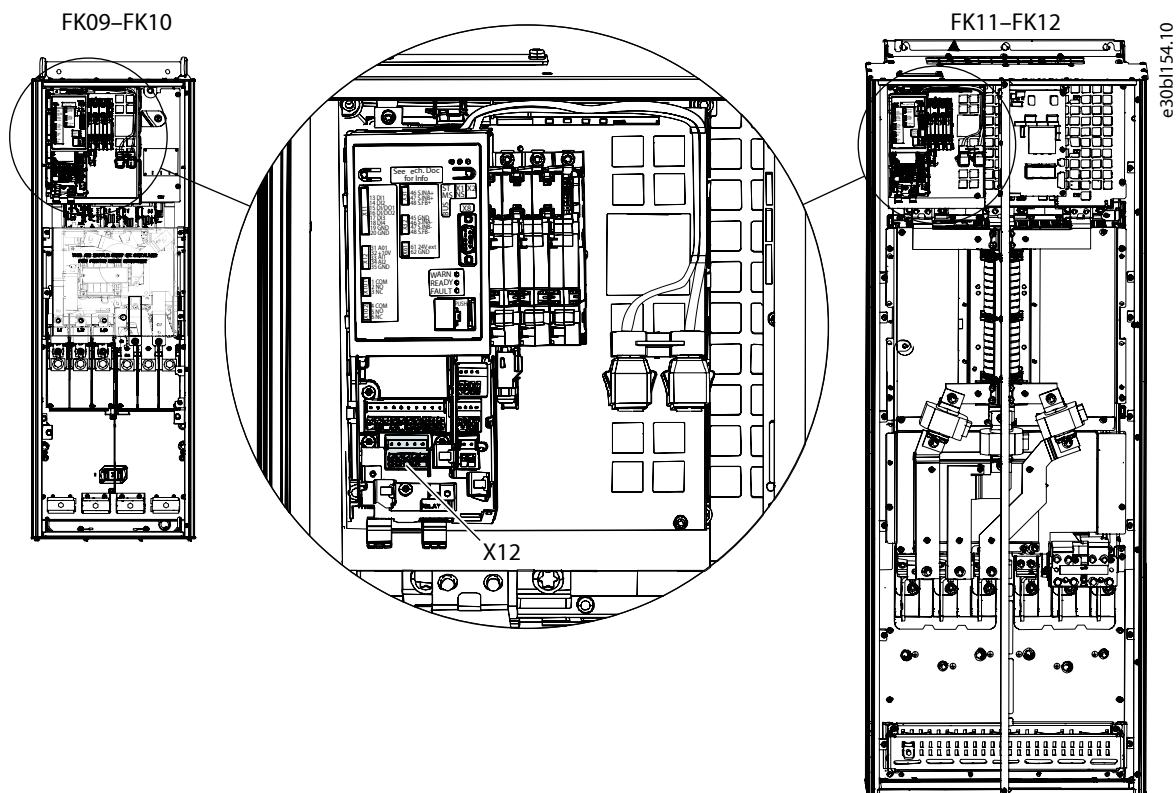

Figure 91: Control Connections in Frames FK06–FK12

### 11.6.10 Control Wire Sizes and Stripping Lengths

Connections are made by pushing solid wire into the connector. If flexible (multicore) wire is used, ferrules are recommended. When flexible wire is used without ferrules, the connector is pushed with a small screwdriver as shown in [Figure 92](#). The maximum size of the screwdriver is 3 mm (2.5 mm for connectors X31 and X32).

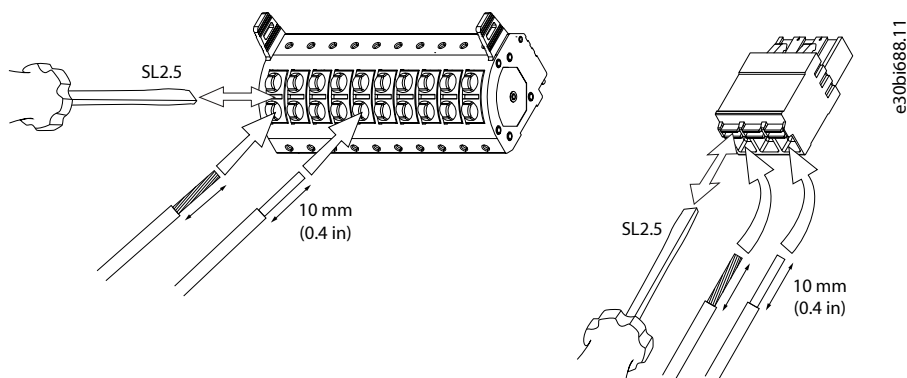

Figure 92: Inserting Wires into the Connector

**Table 82: Cable Sizing for Connectors X31, X32**

Wire type	Cross-section [mm <sup>2</sup> (AWG)]	Stripping length [mm (in)]
Solid	0.2–1.5 (24–16)	10 (0.4)
Flexible	0.2–1.5 (24–16)	10 (0.4)
Flexible with ferrule w/o plastic sleeve	0.5–1.5 (20–16)	10 (0.4)
Flexible with ferrule w plastic sleeve	0.5 (24)	10 (0.4)

**Table 83: Cable Sizing for Connectors X11, X12, X61**

Wire type	Cross-section [mm <sup>2</sup> (AWG)]	Stripping length [mm (in)]
Solid	0.2–2.5 (24–14)	10 (0.4)
Flexible	0.2–2.5 (24–14)	10 (0.4)
Flexible with ferrule without plastic sleeve	0.5–2.5 (20–14)	10 (0.4)
Flexible without ferrule with plastic sleeve	0.5–1 (20–17)	10 (0.4)

**Table 84: Cable Sizing for Connectors X101, X102**

Wire type	Cross-section [mm <sup>2</sup> (AWG)]	Stripping length [mm (in)]
Solid	0.2–2.5 (24–14)	10 (0.4)
Flexible	0.2–2.5 (24–14)	10 (0.4)
Flexible with ferrule without plastic sleeve	0.25–2.5 (24–14)	10 (0.4)
Flexible without ferrule with plastic sleeve	0.25–2.5 (24–14)	10 (0.4)

### 11.6.11 Cable Shield Connection

The cable shield must be completely in contact with the EMC clamp on the EMC plate. Cable isolation must be removed and the cable shield exposed for the entire surface. Avoid pigtailed.

For frames FA02b–FA05b, 2 EMC plates are used.

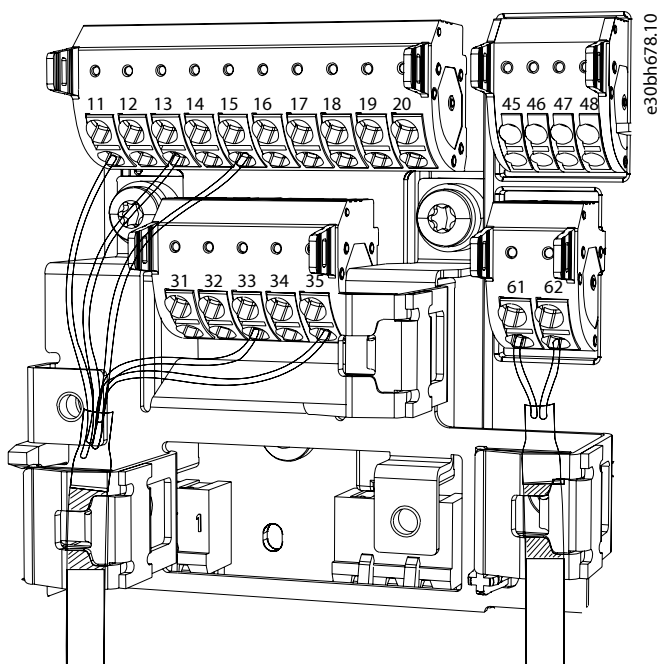

Figure 93: Correct Connection of the Cable Shield

### 11.7 STO Installation Considerations

Due to the galvanic isolation of the safe inputs, various connections and different polarities are possible in the wiring.

For example, connect a safety actuator to safe input terminals, and set the voltage references as shown in [Figure 94](#) and [Figure 95](#). Setups with the same voltage level on both channels (+24 V) are supported, but also setups with different voltage levels (+24 V and GND).

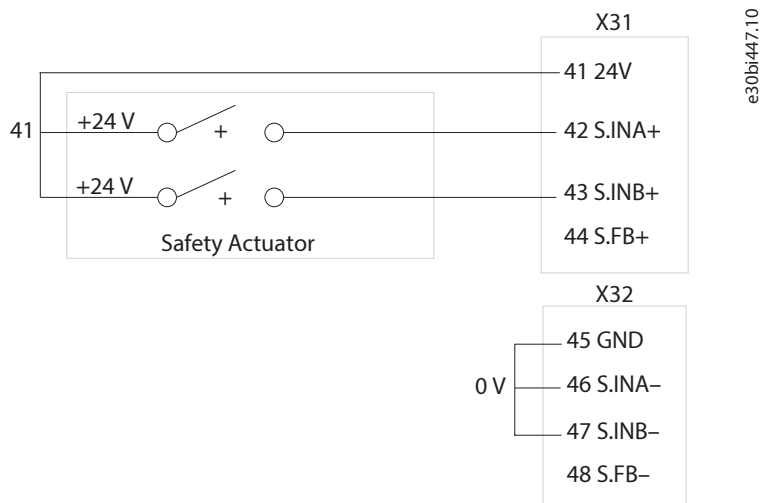
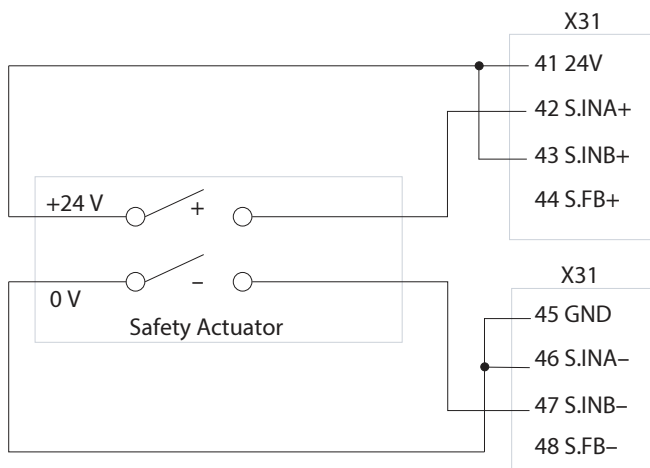

Figure 94: STO Connection Example for Using the Same Polarities (Channel A and Channel B = 24 V)



e30bi446.10

Figure 95: STO Connection Example for Using Different Polarities

For more information on functional safety, refer to *iC7-Automation Frequency Converters Functional Safety Operating Guide*.

## 12 How to Order

### 12.1 Selecting the Frequency Converter

**Prerequisite:** When selecting a frequency converter, the load conditions of the application must always be considered first. Selecting the optimum rating requires knowledge about the load profile of the system, for example the motor current and power, application load characteristics, and operational conditions. For more information about load profiles, see [5.6.1 Load Profile Overview](#).

When selecting a frequency converter, follow these steps to ensure that the drive fulfills the installation and application requirements.

1. Select a power unit and power hardware that match the installation and application requirements.
2. Select control options, functional extensions, communication interfaces, and control panels.
3. Select application software and additional features and/or functionality, if needed.

It is also possible to select filters and braking options, accessories, and Danfoss DrivePro® services. For more information, see the ordering site at <https://www.danfoss.com>.

### 12.2 Model Code

#### 12.2.1 Overview

The configuration of the drive is reflected in the model code. The model code can be used to identify the specific drive configuration and its inbuilt features.

A model code may look like the following example:

**iC7-60FA3N05-43A0E20F1+ACBC+ALDC+BAPR+BDBA+BEF1+BF20+CAC0+CBR0+CCT0+DAAU+DD11+EA000001**

The model code in the example contains the following elements:

**Table 85: Example of a Final Model Code**

Model code	Function
iC7-60	Product group: iC7-60
FA	Product category: Freq. converter, air-cooled
3N	Product type: 3~ (3 phase power supply)
05	Mains voltage: 380–500 V AC
43A0	Current rating: 43 A
E20	Protection rating: IP20/UL Open Type
F1	EMC category: C1 & C2 category (built-in EMC filter)
+ACBC	Integrated brake chopper
+ALDC	DC terminals
+BAPR	Communication interface, X1/X2: Control board with PROFINET RT OS7PR
+BDBA	Standard I/O: 4xDI, 2xDI/O, 2xAI, 1xAO, 2xRO
+BEF1	Safe Torque Off, not upgradable
+BF20	Control Panel 2.8 OPX20
+CAC0	General Purpose I/O OC7C0 in slot A

**Table 85: Example of a Final Model Code** (continued)

Model code	Function
+CBR0	Relay Option OC7R0 in slot B
+CCT0	Temperature Measurement OC7T0 in slot C
+DAAU	iC7-Automation
+DD11	Motion application added to application software

The model code is made up of a mandatory section that describes the basic power hardware (22 characters), and a section that indicates other feature categories (identified as a "Plus code"). Selections in the mandatory part of the model code have fixed positions.

**Table 86: Mandatory Elements in the Model Code**

Position	Example	Function
1–6	iC7-60	Product group
7–8	FA	Product category
9–10	3N	Product type
11–12	05	Mains voltage
14–17	43A0	Current rating
18–20	E20	Protection rating
21–22	F1	EMC category

Further selections are indicated as fixed character strings with a plus sign (+) as the separator between each feature-specific string. The first two characters after the plus sign indicate the feature group, and the remaining characters indicate the selection. When configured, the codes are listed in alphabetical order. A standard selection is defined for the products, which is indicated in this guide in **bold text**, and is not shown in the model code. Only if another selection is made, it is shown in the model code.

The feature category groups are introduced in [Table 87](#).

**Table 87: Plus Code Groups in the Model Code**

Plus code group	Description
+Axxx	Optional power hardware features
+Bxxx	Control hardware
+Cxxx	Control options
+Dxxx	Application software and additional functionality
+Exxx	Customized settings (for reference only)

For more information about the general dependencies in model code plus code groups, see the dedicated sections for each plus code group. In the sections describing each of the plus code groups, the following symbols are used to indicate availability:

- **X** indicates a standard selection.
- **O** indicates an optional selection.



- A dash (–) indicates that the selection is not available.

The dependencies are not described in full detail, but the configurator at [www.danfoss.com](http://www.danfoss.com) supports the correct selections for frequency converters.

### 12.2.2 Power Hardware

When ordering a drive, a selection must be made for each of the mandatory elements. The available selections are shown for each frame in [Table 88](#), [Table 89](#), and [Table 90](#).

**Table 88: Mandatory Power Hardware Elements for IP20/UL Open Type Drives (FA02–FA12)**

Element	Code	Description	FA02–FA05	FA06–FA08	FA09–FA12
Product group	iC7-60	iC7-60	X	X	X
Product category	FA	Frequency converter, air-cooled	X	X	X
Product type	3N	3~ (3 phase)	X	X	X
Mains voltage <sup>(1)</sup>	05	380–500 V AC	X	X	X
Current rating <sup>(1)</sup>	01A3–1260	The drive rating in amperes.	See <a href="#">8.2.2 Ratings for Frequency Converters with 380–500 V Supply Voltage</a> .		
Protection rating	E20	IP20/UL Open type	X	X	X
EMC category <sup>(2)</sup>	F1	C1 and C2 category	X	X	–
	F2	C2 category	X	X	X
	F3	C3 category	X	X	X

1) The mains voltage and current rating codes form the product code that is used to identify a frame, for example, in the product label and in the technical specifications in this guide.

2) For more information on the compliance level and recommended cable lengths, see [8.10.1 EMC Compliance Levels](#).

**Table 89: Mandatory Power Hardware Elements for IP21/UL Type 1 Drives (FK06–FK12)**

Element	Code	Description	FK06–FK08	FK09–FK12
Product group	iC7-60	iC7-60	X	X
Product category	FA	Frequency converter, air-cooled	X	X
Product type	3N	3~ (3 phase)	X	X
Mains voltage <sup>(1)</sup>	05	380–500 V AC	X	X
Current rating <sup>(1)</sup>	01A3–1260	The drive rating in amperes.	See <a href="#">8.2.2 Ratings for Frequency Converters with 380–500 V Supply Voltage</a> .	
Protection rating	E21	IP21/UL Type 1	X	X
EMC category <sup>(2)</sup>	F1	C1 and C2 category	X	–
	F2	C2 category	X	X
	F3	C3 category	X	X

1) The mains voltage and current rating codes form the product code that is used to identify a frame, for example, in the product label and in the technical specifications in this guide.

2) For more information on the compliance level and recommended cable lengths, see [8.10.1 EMC Compliance Levels](#).

Table 90: Mandatory Power Hardware Elements for IP54/IP55/UL Type 12 Drives (FB09–FB12)

Element	Code	Description	FB09–FB12
Product group	iC7-60	iC7-60	X
Product category	FA	Frequency converter, air-cooled	X
Product type	3N	3~ (3 phase)	X
Mains voltage <sup>(1)</sup>	05	380–500 V AC	X
Current rating <sup>(1)</sup>	01A3–1260	The drive rating in amperes.	See <a href="#">8.2.2 Ratings for Frequency Converters with 380–500 V Supply Voltage</a> .
Protection rating	E54	IP54/UL Type 12	X
EMC category <sup>(2)</sup>	F1	C1 and C2 category	–
	F2	C2 category	X
	F3	C3 category	X

1) The mains voltage and current rating codes form the product code that is used to identify a frame, for example, in the product label and in the technical specifications in this guide.

2) For more information on the compliance level and recommended cable lengths, see [8.10.1 EMC Compliance Levels](#).

### 12.2.3 Optional Power Hardware (+Axxx)

Additional hardware features can be selected as listed in [Table 91](#), [Table 92](#), and [Table 93](#). If a selection is not made when ordering a drive, the standard selection (shown in bold) is applied.

Table 91: Optional Power Hardware Components (Category +Axxx) for IP20/UL Open Type Drives (FA02–FA12)

Function	Model code	Selection description	FA02–FA05	FA06–FA08	FA09–FA12
Integrated brake chopper	<b>+ACXX</b>	None	–	X	X
	+ACBC	Yes <sup>(1)</sup>	X	O	O <sup>(2)</sup>
Extra environmental protection	<b>+AGXX</b>	None	X	X	–
	+AGCX	Coated boards	O	O	X
Mains input device	<b>+AJXX</b>	None	X	X	X
	+AJFX	AC fuses	–	–	O
DC terminals	<b>+ALXX</b>	None	–	X	X
	+ALDC	Yes	X	O	O <sup>(2)</sup>
Heat sink access panel	<b>+APXX</b>	None	X	X	X
	+APHS	Yes	–	–	O

1) Not applicable to model 05-385A.

2) DC terminals and brake chopper cannot be combined. DC terminals are not available for FA11 and FA12 frames.

Table 92: Optional Power Hardware Components (Category +Axxx) for IP21/UL Type 1 Drives (FK06–FK12)

Function	Model code	Selection description	FK06–FK08	FK09–FK12
Integrated brake chopper	+ACXX	None	X	X
	+ACBC	Yes <sup>(1)</sup>	O <sup>(2)</sup>	O <sup>(3)</sup>
Extra environmental protection	+AGXX	None	X	–
	+AGCX	Coated boards	O	X
Humidity protection device	+AHXX	None	X	X
	+AHHS	Space Heater	–	O
Integrated common-mode filter	+AIXX	None	X	X
	+AIC1	Yes	–	X <sup>(4)</sup>
Mains input device	+AJXX	None	X	–
	+AJFX	AC fuses	O	X
	+AJXD	Mains switch	O <sup>(2)</sup>	–
	+AJFD	AC fuses and mains switch	O <sup>(2)</sup>	O
DC terminals	+ALXX	None	X	X
	+ALDC	Yes	O <sup>(2)</sup>	O <sup>(3)</sup>
Touch protection	+AMXX	None	X	X
	+AMMX	Yes	–	O
Heat sink access panel	+APXX	None	X	X
	+APHS	Yes	–	O

1) Not applicable to model 05-385A.

2) Integrated brake chopper and DC terminals cannot be combined with Mains input device (Mains switch or AC fuses and mains switch).

3) DC terminals and brake chopper cannot be combined. DC and brake are not available in FK09a and FK10a frames. DC terminals are not available in FK11 and FK12 frames.

4) Only applies to FK09c and FK10c.

Table 93: Optional Power Hardware Components (Category +Axxx) for IP54/IP55/UL Type 12 Drives (FB09–FB12)

Function	Model code	Selection description	FB09–FB12
Integrated brake chopper	+ACXX	None	X
	+ACBC	Yes <sup>(3)</sup>	O <sup>(3)</sup>
Extra environmental protection	+AGXX	None	–
	+AGCX	Coated boards	X
Humidity protection device	+AHXX	None	X
	+AHHS	Space heater	O
Integrated common-mode filter	+AIXX	None	X
	+AIC1	Yes	X <sup>(3)</sup>

**Table 93: Optional Power Hardware Components (Category +Axxx) for IP54/IP55/UL Type 12 Drives (FB09–FB12) (continued)**

Function	Model code	Selection description	FB09–FB12
Mains input device	+AJXX	None	X
	+AJFX	AC fuses	O
	+AJXD	Mains switch	–
	+AJFD	AC fuses and mains switch	O
DC terminals	+ALXX	None	X
	+ALDC	Yes	O <sup>(3)</sup>
Touch protection	+AMXX	None	X
	+AMMX	Yes	O
Heat sink access panel	+APXX	None	X
	+APHS	Yes	O

1) Not applicable to model 05-385A.

2) DC terminals and brake chopper cannot be combined. DC and brake are not available in FB09a and FB10a frames. DC terminals are not available in FB11 and FB12 frames.

3) Only applies to FB09c and FB10c.

## 12.2.4 Control Board Features (+Bxxx)

Available selections for control board functionalities are listed in [Table 94](#). If a selection is not made, the standard configuration (shown in bold) is applied. The control board type (code +BAxx) and functional safety type (code +BExx) must always be selected.

**Table 94: Control Board Features in the Model Code**

Function	Model code	Selection description
Communication interface, X1/X2	+BAMT	Modbus TCP OS7MT
	+BAPR	PROFINET RT OS7PR
	+BAIP	EtherNet/IP OS7IP
	+BAEC	EtherCAT OS7EC
Standard I/O	<b>+BDXX</b>	<b>None</b>
	+BDDBA	Basic I/O (4 x DI, 2 x combined DI/DO, 2 x AI, 1 x AO, 2 x Relay)
Functional safety	+BEF1	Safe Torque Off – Not upgradable
	+BEF2	STO, SS1-t, fieldbus <sup>(1)</sup>
Control panel	<b>+BF00<sup>(2)</sup></b>	<b>Blind Panel OPX00</b>
	+BF20	Control Panel 2.8 OPX20

1) iC7-Automation frequency converters support PROFI-safe. More fieldbuses will be supported in future releases.

2) Not available for Fx09–Fx12.

## 12.2.5 Functional Extension Options (+Cxxx)

For guidance on option slots, see [Table 95](#).

The final code of the selection depends on the slot which the option is installed in. For example, when installing the General Purpose I/O OC7C0 option in slot B, the code is +CBC0.

**Table 95: Functional Extension Model Codes**

Model Code					Function
Slot A	Slot B	Slot C	Slot D	Slot E	
–	<b>+CBXX</b>	–	–	–	None – Not upgradable <sup>(1)</sup>
<b>+CAXO</b>	+CBX0	<b>+CCX0</b>	<b>+CDX0</b>	<b>+CEX0</b>	None
+CAC0	+CBC0	+CCC0	+CDC0	+CEC0	General Purpose I/O OC7C0
+CAR0	+CBR0	+CCR0	+CDR0	+CER0	Relay Option OC7R0
+CAM0	–	–	–	–	Encoder/Resolver Option OC7M0
+CAT0	+CBT0	+CCT0	+CDT0	+CET0	Temperature Measurement OC7T0

1) If only 1 option is required for frames FA02–FA05, select +CBXX. The frame designations are FA02a–FA05a.

### 12.2.6 Application Software and Additional Functionality (+Dxxx)

The available selections for application software and additional functionalities are listed in [Table 96](#). If a selection is not made when ordering a drive, the standard selection (shown in bold) is applied.

**Table 96: Application Software and Additional Feature Selections in the Model Code**

Function	Model code	Selection description
Product series	+DAAU	iC7-Automation
Additional drive features 1	<b>+DD1X</b>	<b>None</b>
	+DD11	Motion
High speed enabled	<b>+DI6X</b>	None
	+DI61	Enabled <sup>(1)</sup>

1) Only with special agreement due to dual-use restrictions.

### 12.2.7 Customized Settings (+Exxx)

The selections for customized settings are typically based on settings that are not selectable in the standard product offering. They are only shown to indicate possible variants.

**Table 97: Customized Settings in the Model Code**

Function	Model code	Selection description
Customization file package ID	<b>+EAXXXXXX</b>	Customized settings of the drive indicated by a 6-digit alphanumeric value
Product software ID	<b>+ECXX</b>	Latest released version <sup>(1)</sup>
Technical documentation	+EGXX	None <sup>(2)</sup>
	<b>+EGIN</b>	<b>Installation guide included</b>

**Table 97: Customized Settings in the Model Code** (continued)

Function	Model code	Selection description
Customer specific label	+EJXX	No
	+EJCL	Yes

1) By default, drives are shipped with latest released software (+ECXX). If shipped with a different version, the code is different and can be read in the model code information of the drive.

2) With special agreement only.

## 12.3 Ordering Filters and Braking Options

### 12.3.1 Harmonic Filters

#### 12.3.1.1 Harmonic Filters Selection Guidelines

The Advanced Harmonic Filter OF7P2 must be selected to match the input current rating of the frequency converter.

Multiple frequency converters can be connected to a single filter. In this case, input fusing is required for the filter and each drive. The fuse must be selected according to drive fuse selection guidelines. When installing 1 advanced harmonic filter to 1 drive, fuses can be moved from the input of the drive to the input of the filter only.

Danfoss recommends using Danfoss filters with iC7-Automation frequency converters. For more information, see filter documentation.

#### 12.3.1.2 Advanced Harmonic Filter OF7P2, 380–415 V, 50 Hz Supply

**Table 98: Terminology Used in the Advanced Harmonic Filter Selection Table**

Term	Description
Product code	Frequency converter product code. The product code consists of the mains voltage code and the current rating code of the model code.
Rated input current	The rated input current of the frequency converter as RMS and the theoretical fundamental value in the selected overload capability. The RMS value is the effective value of the input currents including harmonics above the fundamental current or grid frequency. The nominal input current to frequency converter corresponds to the fundamental value when combined with an advanced harmonic filter.
Code no.	The code number of the filter that matches the frequency converter operating conditions. Protection ratings are IP20 and UL Open Type. An optional IP21/UL Type 1 upgrade kit is available for improved protection. The optional IP21/UL Type 1 kit is available in 2 versions: with and without integrated capacitor disconnect circuitry.
Frame	The frame designation of the filter. The frame designation is used as a reference when selecting the optional IP21/UL Type 1 kits.

Table 99: Selection Table for Advanced Harmonic Filter OF7P2, 380–415 V, 50 Hz Grid

Frequency converter				Advanced Harmonic Filter OF7P2				
Product code	Overload rating	Rated input current 380–440 V		Rated current 380–415 V 50 Hz [A]	IP20/UL Open Type			
		RMS [A]	Fundamental [A]		THDi: 5%		THDi: 10%	
					Frame	Code no.	Frame	Code no.
05-01A3	All	1.1	–	–	P2AX1i	132N6802	P2AX1i	132N6818
05-01A8	All	1.5	–	–	P2AX1i	132N6802	P2AX1i	132N6818
05-02A4	All	2.0	–	–	P2AX1i	132N6802	P2AX1i	132N6818
05-003A	All	2.6	–	–	P2AX1i	132N6802	P2AX1i	132N6818
05-004A	All	3.5	–	–	P2AX1i	132N6802	P2AX1i	132N6818
05-05A6	All	5.0	–	–	P2AX1i	132N6802	P2AX1i	132N6818
05-07A2	All	6.5	–	–	P2AX1i	132N6802	P2AX1i	132N6818
05-09A2	All	8.8	–	–	P2AX1i	132N6802	P2AX1i	132N6818
05-12A5	All	11.2	–	–	P2AX1i	132N6802	P2AX1i	132N6818
05-16A0	All	15.3	–	–	P2AX1e	132N6803	P2AX1e	132N6819
05-24A0	All	22.0	–	–	P2AX2e	132N6804	P2AX2i	132N6820
05-31A0	All	30.0	–	–	P2AX2e	132N6805	P2AX2i	132N6821
05-38A0	All	36.0	–	–	P2AX3i	132N6806	P2AX3i	132N6822
05-43A0	All	43.0	–	–	P2AX3i	132N6807	P2AX3i	132N6823
05-61A0	All	57.0	–	–	P2AX3i	132N6808	P2AX3i	132N6824
05-73A0	All	70.0	–	–	P2AX4i	132N6809	P2AX4i	132N6825
05-90A0	All	85.0	–	–	P2AX4e	132N6810	P2AX4e	132N6826
05-106A	All	103.0	–	–	P2AX5e	132N6811	P2AX5e	132N6827
05-147A	All	139.0	–	–	P2AX5e	132N6812	P2AX5e	132N6828
05-170A	All	167.0	–	–	P2AX6e	132N6813	P2AX6i	132N6829
05-206A	LO	198.0	–	–	P2AX6e	132N6814	P2AX6i	132N6831
	HO1	164.0	–	–	P2AX6e	132N6813	P2AX6i	132N6829
05-245A	LO	236.0	–	–	P2AX7i	132N6815	P2AX7i	132N6832
	HO1	198.0	–	–	P2AX6e	132N6814	P2AX6i	132N6831
05-302A	LO	291.0	–	–	P2AX7i	132N6816	P2AX7i	132N6833
	HO1	236.0	–	–	P2AX7i	132N6815	P2AX7i	132N6832
05-385A	LO	371.0	–	–	P2AX8e	132N9618	P2AX7i	132N9620
	HO1	291.0	–	–	P2AX7i	132N6816	P2AX7i	132N6833

Table 99: Selection Table for Advanced Harmonic Filter OF7P2, 380–415 V, 50 Hz Grid (continued)

Frequency converter				Advanced Harmonic Filter OF7P2				
Product code	Overload rating	Rated input current 380–440 V		Rated current 380–415 V 50 Hz [A]	IP20/UL Open Type			
		RMS [A]	Fundamental [A]		THDi: 5%		THDi: 10%	
					Frame	Code no.	Frame	Code no.
05-395A	LO	380.0	–	–	P2AX8e	132N9618	P2AX7i	132N9620
	HO1	291.0	–	–	P2AX7i	132N6816	P2AX7i	132N6833
05-480A	LO	462.0	–	–	P2AX8e	132N9619	P2AX8e	132N9621
	HO1	371.0	–	–	P2AX8e	132N9618	P2AX7i	132N9620
05-588A	LO	566.0	–	–	P2AX7i	2 x 132N6816	P2AX7i	2 x 132N6833
	HO1	462.0	–	–	P2AX8e	132N9619	P2AX8e	132N9621
05-685A	LO	633.0	–	–	P2AX8i	2 x 132N6817	P2AX7i	2 x 132N6834
	HO1	566.0	–	–	P2AX7i	2 x 132N6816	P2AX7i	2 x 132N6833
05-736A	LO	709.0	–	–	P2AX8e	2 x 132N9618	P2AX7i	2 x 132N9620
	HO1	633.0	–	–	P2AX8i	2 x 132N6817	P2AX7i	2 x 132N6834
05-799A	LO	769.0	–	–	P2AX8e	2 x 132N9618	P2AX7i	2 x 132N9620
	HO1	669.0	–	–	P2AX8e	2 x 132N9618	P2AX7i	2 x 132N9620
05-893A	LO	860.0	–	–	P2AX8e	2 x 132N9619	P2AX8e	2 x 132N9621
	HO1	769.0	–	–	P2AX8e	2 x 132N9618	P2AX7i	2 x 132N9620
05-1000	LO	963.0	–	–	P2AX8e	2 x 132N9619	P2AX8e	2 x 132N9621
	HO1	847.0	–	–	P2AX8e	2 x 132N9619	P2AX8e	2 x 132N9621
05-1120	LO	1078.0	–	–	P2AX8e	3 x 132N9618	P2AX7i	3 x 132N9620
	HO1	963.0	–	–	P2AX8e	2 x 132N9619	P2AX8e	2 x 132N9621



Table 99: Selection Table for Advanced Harmonic Filter OF7P2, 380–415 V, 50 Hz Grid (continued)

Frequency converter				Advanced Harmonic Filter OF7P2				
Product code	Overload rating	Rated input current 380–440 V		Rated current 380–415 V 50 Hz [A]	IP20/UL Open Type			
		RMS [A]	Fundamental [A]		THDi: 5%		THDi: 10%	
					Frame	Code no.	Frame	Code no.
05-1260	LO	1200.0	–	–	P2AX8e	3 x 132N9619	P2AX8e	3 x 132N9621
	HO1	1059.0	–	–	P2AX8e	3 x 132N9618	P2AX7i	3 x 132N9620

### 12.3.1.3 Advanced Harmonic Filter OF7P2, 380–415 V, 60 Hz Supply

Table 100: Terminology Used in the Advanced Harmonic Filter Selection Table

Term	Description
Product code	Frequency converter product code. The product code consists of the mains voltage code and the current rating code of the model code.
Rated input current	The rated input current of the frequency converter as RMS and the theoretical fundamental value in the selected overload capability. The RMS value is the effective value of the input currents including harmonics above the fundamental current or grid frequency. The nominal input current to frequency converter corresponds to the fundamental value when combined with an advanced harmonic filter.
Code no.	The code number of the filter that matches the frequency converter operating conditions. Protection ratings are IP20 and UL Open Type. An optional IP21/UL Type 1 upgrade kit is available for improved protection. The optional IP21/UL Type 1 kit is available in 2 versions: with and without integrated capacitor disconnect circuitry.
Frame	The frame designation of the filter. The frame designation is used as a reference when selecting the optional IP21/UL Type 1 kits.

Table 101: Selection Table for Advanced Harmonic Filter OF7P2, 380–415 V, 60 Hz Supply

Frequency converter				Advanced Harmonic Filter OF7P2				
Product code	Overload rating	Rated input current 380–440 V		Rated current 380–415 V 60 Hz [A]	IP20/UL Open Type			
		RMS [A]	Fundamental [A]		THDi: 5%		THDi: 10%	
					Frame	Code no.	Frame	Code no.
05-01A3	All	1.1	–	–	P2AX1i	132N6491	P2AX1i	132N6785
05-01A8	All	1.5	–	–	P2AX1i	132N6491	P2AX1i	132N6785
05-02A4	All	2.0	–	–	P2AX1i	132N6491	P2AX1i	132N6785
05-003A	All	2.6	–	–	P2AX1i	132N6491	P2AX1i	132N6785

Table 101: Selection Table for Advanced Harmonic Filter OF7P2, 380–415 V, 60 Hz Supply (continued)

Frequency converter					Advanced Harmonic Filter OF7P2			
Product code	Overload rating	Rated input current 380–440 V		Rated current 380–415 V 60 Hz [A]	IP20/UL Open Type			
		RMS [A]	Fundamental [A]		THDi: 5%		THDi: 10%	
					Frame	Code no.	Frame	Code no.
05-004A	All	3.5	–	–	P2AX1i	132N6491	P2AX1i	132N6785
05-05A6	All	5.0	–	–	P2AX1i	132N6491	P2AX1i	132N6785
05-07A2	All	6.5	–	–	P2AX1i	132N6491	P2AX1i	132N6785
05-09A2	All	8.8	–	–	P2AX1i	132N6491	P2AX1i	132N6785
05-12A5	All	11.2	–	–	P2AX1i	132N6491	P2AX1i	132N6785
05-16A0	All	15.3	–	–	P2AX1e	132N6492	P2AX1e	132N6786
05-24A0	All	22.0	–	–	P2AX2e	132N6496	P2AX2i	132N6787
05-31A0	All	30.0	–	–	P2AX2e	132N6497	P2AX2i	132N6788
05-38A0	All	36.0	–	–	P2AX3i	132N6498	P2AX3i	132N6789
05-43A0	All	43.0	–	–	P2AX3i	132N6499	P2AX3i	132N6790
05-61A0	All	57.0	–	–	P2AX3i	132N6500	P2AX3i	132N6791
05-73A0	All	70.0	–	–	P2AX4i	132N6501	P2AX4i	132N6792
05-90A0	All	85.0	–	–	P2AX4e	132N6502	P2AX4e	132N6793
05-106A	All	103.0	–	–	P2AX5e	132N6503	P2AX5e	132N6794
05-147A	All	139.0	–	–	P2AX5e	132N6506	P2AX5e	132N6795
05-170A	All	167.0	–	–	P2AX6e	132N6510	P2AX6i	132N6796
05-206A	LO	198.0	–	–	P2AX7i	132N6511	P2AX6i	132N6798
	HO1	164.0	–	–	P2AX6e	132N6510	P2AX6i	132N6796
05-245A	LO	236.0	–	–	P2AX7i	132N6512	P2AX7i	132N6799
	HO1	198.0	–	–	P2AX7i	132N6511	P2AX6i	132N6798
05-302A	LO	291.0	–	–	P2AX8i	132N6513	P2AX7i	132N6800
	HO1	236.0	–	–	P2AX7i	132N6512	P2AX7i	132N6799
05-385A	LO	371.0	–	–	P2AX8e	132N6514	P2AX7e	132N6801
	HO1	291.0	–	–	P2AX8i	132N6513	P2AX7i	132N6800
05-395A	LO	380.0	–	–	P2AX8e	132N6514	P2AX7e	132N6801
	HO1	291.0	–	–	P2AX8i	132N6513	P2AX7i	132N6800
05-480A	LO	462.0	–	–	P2AX8e	132N9615	P2AX8e	132N9617
	HO1	371.0	–	–	P2AX8e	132N6514	P2AX7e	132N6801

Table 101: Selection Table for Advanced Harmonic Filter OF7P2, 380–415 V, 60 Hz Supply (continued)

Frequency converter					Advanced Harmonic Filter OF7P2			
Product code	Overload rating	Rated input current 380–440 V		Rated current 380–415 V 60 Hz [A]	IP20/UL Open Type			
		RMS [A]	Fundamental [A]		THDi: 5%		THDi: 10%	
					Frame	Code no.	Frame	Code no.
05-588A	LO	566.0	–	–	P2AX8i	2 x 132N6513	P2AX7i	2 x 132N6800
	HO1	462.0	–	–	P2AX8e	132N9615	P2AX8e	132N9617
05-685A	LO	633.0	–	–	P2AX8e	2 x 132N6514	P2AX7e	2 x 132N6801
	HO1	566.0	–	–	P2AX8i	2 x 132N6513	P2AX7i	2 x 132N6800
05-736A	LO	709.0	–	–	P2AX8e	2 x 132N6514	P2AX7e	2 x 132N6801
	HO1	633.0	–	–	P2AX8e	2 x 132N6514	P2AX7e	2 x 132N6801
05-799A	LO	769.0	–	–	P2AX8e	2 x 132N9614	P2AX7e	2 x 132N9616
	HO1	669.0	–	–	P2AX8e	2 x 132N9614	P2AX7e	2 x 132N9616
05-893A	LO	860.0	–	–	P2AX8e	2 x 132N9615	P2AX8e	2 x 132N9617
	HO1	769.0	–	–	P2AX8e	2 x 132N9614	P2AX7e	2 x 132N9616
05-1000	LO	963.0	–	–	P2AX8e	2 x 132N9615	P2AX8e	2 x 132N9617
	HO1	847.0	–	–	P2AX8e	2 x 132N9615	P2AX8e	2 x 132N9617
05-1120	LO	1078.0	–	–	P2AX8e	3 x 132N9614	P2AX7e	3 x 132N9616
	HO1	963.0	–	–	P2AX8e	2 x 132N9615	P2AX8e	2 x 132N9617
05-1260	LO	1200.0	–	–	P2AX8e	3 x 132N9615	P2AX8e	3 x 132N9617
	HO1	1059.0	–	–	P2AX8e	3 x 132N9614	P2AX7e	3 x 132N9616

## 12.3.1.4 Advanced Harmonic Filter OF7P2, 440–480 V, 60 Hz Supply

Table 102: Terminology Used in the Advanced Harmonic Filter Selection Table

Term	Description
Product code	Frequency converter product code. The product code consists of the mains voltage code and the current rating code of the model code.
Rated input current	The rated input current of the frequency converter as RMS and the theoretical fundamental value in the selected overload capability. The RMS value is the effective value of the input currents including harmonics above the fundamental current or grid frequency. The nominal input current to frequency converter corresponds to the fundamental value when combined with an advanced harmonic filter.
Code no.	The code number of the filter that matches the frequency converter operating conditions. Protection ratings are IP20 and UL Open Type. An optional IP21/UL Type 1 upgrade kit is available for improved protection. The optional IP21/UL Type 1 kit is available in 2 versions: with and without integrated capacitor disconnect circuitry.
Frame	The frame designation of the filter. The frame designation is used as a reference when selecting the optional IP21/UL Type 1 kits.

Table 103: Selection Table for Advanced Harmonic Filter OF7P2, 440–480 V, 60 Hz Supply

Frequency converter				Advanced Harmonic Filter OF7P2				
Product code	Overload rating	Rated input current 441–500 V		Rated current 440–480 V 60 Hz [A]	IP20/UL Open Type			
		RMS [A]	Fundamental [A]		THDi: 5%		THDi: 10%	
					Frame	Code no.	Frame	Code no.
05-01A3	All	0.9	–	–	P2AX1i	132N6491	P2AX1i	132N6785
05-01A8	All	1.3	–	–	P2AX1i	132N6491	P2AX1i	132N6785
05-02A4	All	1.8	–	–	P2AX1i	132N6491	P2AX1i	132N6785
05-003A	All	2.3	–	–	P2AX1i	132N6491	P2AX1i	132N6785
05-004A	All	3.1	–	–	P2AX1i	132N6491	P2AX1i	132N6785
05-05A6	All	4.3	–	–	P2AX1i	132N6491	P2AX1i	132N6785
05-07A2	All	5.7	–	–	P2AX1i	132N6491	P2AX1i	132N6785
05-09A2	All	7.4	–	–	P2AX1i	132N6491	P2AX1i	132N6785
05-12A5	All	9.8	–	–	P2AX1i	132N6491	P2AX1i	132N6785
05-16A0	All	13.4	–	–	P2AX1e	132N6492	P2AX1e	132N6786
05-24A0	All	20.0	–	–	P2AX2e	132N6496	P2AX2i	132N6787
05-31A0	All	26.0	–	–	P2AX2e	132N6497	P2AX2i	132N6788
05-38A0	All	31.0	–	–	P2AX3i	132N6498	P2AX3i	132N6789
05-43A0	All	37.0	–	–	P2AX3i	132N6499	P2AX3i	132N6790

Table 103: Selection Table for Advanced Harmonic Filter OF7P2, 440–480 V, 60 Hz Supply (continued)

Frequency converter				Advanced Harmonic Filter OF7P2				
Product code	Overload rating	Rated input current 441–500 V		Rated current 440–480 V 60 Hz [A]	IP20/UL Open Type			
		RMS [A]	Fundamental [A]		THDi: 5%		THDi: 10%	
					Frame	Code no.	Frame	Code no.
05-61A0	All	50.0	–	–	P2AX3i	132N6500	P2AX3i	132N6791
05-73A0	All	61.0	–	–	P2AX4i	132N6501	P2AX4i	132N6792
05-90A0	All	74.0	–	–	P2AX4e	132N6502	P2AX4e	132N6793
05-106A	All	90.0	–	–	P2AX5e	132N6503	P2AX5e	132N6794
05-147A	All	122.0	–	–	P2AX5e	132N6506	P2AX5e	132N6795
05-170A	All	145.0	–	–	P2AX6e	132N6510	P2AX6i	132N6796
05-206A	LO	189.0	–	–	P2AX7i	132N6511	P2AX6i	132N6798
	HO1	160.0	–	–	P2AX6e	132N6510	P2AX6i	132N6796
05-245A	LO	231.0	–	–	P2AX7i	132N6512	P2AX7i	132N6799
	HO1	189.0	–	–	P2AX7i	132N6511	P2AX6i	132N6798
05-302A	LO	291.0	–	–	P2AX8i	132N6513	P2AX7i	132N6800
	HO1	231.0	–	–	P2AX7i	132N6512	P2AX7i	132N6799
05-385A	LO	350.0	–	–	P2AX8e	132N6514	P2AX7e	132N6801
	HO1	291.0	–	–	P2AX8i	132N6513	P2AX7i	132N6800
05-395A	LO	350.0	–	–	P2AX8e	132N6514	P2AX7e	132N6801
	HO1	291.0	–	–	P2AX8i	132N6513	P2AX7i	132N6800
05-480A	LO	439.0	–	–	P2AX8e	132N9615	P2AX8e	132N9617
	HO1	350.0	–	–	P2AX8e	132N6514	P2AX7e	132N6801
05-588A	LO	501.0	–	–	P2AX8i	2 x 132N6513	P2AX7i	2 x 132N6800
	HO1	439.0	–	–	P2AX8e	132N9615	P2AX8e	132N9617
05-685A	LO	568.0	–	–	P2AX8i	2 x 132N6513	P2AX7i	2 x 132N6800
	HO1	501.0	–	–	P2AX8i	2 x 132N6513	P2AX7i	2 x 132N6800
05-736A	LO	633.0	–	–	P2AX8e	2 x 132N6514	P2AX7e	2 x 132N6801
	HO1	568.0	–	–	P2AX8i	2 x 132N6513	P2AX7i	2 x 132N6800

Table 103: Selection Table for Advanced Harmonic Filter OF7P2, 440–480 V, 60 Hz Supply (continued)

Frequency converter				Advanced Harmonic Filter OF7P2				
Product code	Overload rating	Rated input current 441–500 V		Rated current 440–480 V 60 Hz [A]	IP20/UL Open Type			
		RMS [A]	Fundamental [A]		THDi: 5%		THDi: 10%	
					Frame	Code no.	Frame	Code no.
05-799A	LO	703.0	–	–	P2AX8e	2 x 132N6514	P2AX7e	2 x 132N6801
	HO1	629.0	–	–	P2AX8e	2 x 132N6514	P2AX7e	2 x 132N6801
05-893A	LO	755.0	–	–	P2AX8e	2 x 132N9614	P2AX7e	2 x 132N9616
	HO1	674.0	–	–	P2AX8e	2 x 132N6514	P2AX7e	2 x 132N6801
05-1000	LO	863.0	–	–	P2AX8e	2 x 132N9615	P2AX8e	2 x 132N9617
	HO1	755.0	–	–	P2AX8e	2 x 132N9614	P2AX7e	2 x 132N9616
05-1120	LO	990.0	–	–	P2AX8e	3 x 132N6514	P2AX7e	3 x 132N6801
	HO1	863.0	–	–	P2AX8e	2 x 132N9615	P2AX8e	2 x 132N9617
05-1260	LO	1107.0	–	–	P2AX8e	3 x 132N9614	P2AX7e	3 x 132N9616
	HO1	990.0	–	–	P2AX8e	3 x 132N6514	P2AX7e	3 x 132N6801

### 12.3.1.5 IP21/UL Type 1 Kits and Backplates for Advanced Harmonic Filter OF7P2

Table 104: Terminology Used in Advanced Harmonic Filter OF7P2 IP21/UL Type 1 Kit Selection Tables

Term	Description
Frame	Cabinet designation of the filter with IP20/UL Type 1 protection rating.
IP21/Type 1 kit	The optional kits are designed as generic kits that match the individual cabinets of the harmonic filter. The upgrade kit is meant for field installation.
Basic kit	Basic kit without integrated circuitry for disconnecting the capacitors in the filter. This kit upgrades the protection rating of the filter to IP21/UL Type 1.

**Table 104: Terminology Used in Advanced Harmonic Filter OF7P2 IP21/UL Type 1 Kit Selection Tables** (continued)

Term	Description
With integrated circuitry	Basic kit with integrated circuitry for disconnecting the capacitors in the filter. This kit upgrades the filter to IP21/UL Type 1 protection rating and includes integrated circuitry for disconnecting the capacitors in the filter by a dedicated frequency converter control function. The kits are generic kits that support the complete harmonic filter program with individual settings matching the grid supply voltage.
Frame IP21/Type 1	The cabinet designation of the complete filter with the IP21/UL Type 1 kit mounted.

**Table 105: Accessories for Advanced Harmonic Filter OF7P2**

IP21 upgrade kit (accessory)				Backplate
Basic kit		Kit with integrated capacitor disconnect circuitry		
Name	Code number	Name	Code number	Code number
IP21/UL Type 1 kit - P2KX1b	136B3119	IP21/UL Type 1 kit w/contactor - P2KX1b	136B3132	130B3283
IP21/UL Type 1 kit - P2KX2b	136B3120	IP21/UL Type 1 kit w/contactor - P2KX2b	136B3133	130B3284
IP21/UL Type 1 kit - P2KX3b	136B3121	IP21/UL Type 1 kit w/contactor - P2KX3b	136B3134	130B3285
IP21/UL Type 1 kit - P2KX4b	136B3122	IP21/UL Type 1 kit w/contactor - P2KX4b	136B3135	130B3286
IP21/UL Type 1 kit - P2KX5b	136B3123	IP21/UL Type 1 kit w/contactor - P2KX5b	136B3136	130B3287
IP21/UL Type 1 kit - P2KX6b	136B3124	IP21/UL Type 1 kit w/contactor - P2KX6b	136B3137	130B3287
IP21/UL Type 1 kit - P2KX7b	136B3125	IP21/UL Type 1 kit w/contactor - P2KX7b	136B3138	130B3288
IP21/UL Type 1 kit - P2KX8b	136B3126	IP21/UL Type 1 kit w/contactor - P2KX8b	136B3139	130B3288

## 12.3.2 Sine-wave Filters

### 12.3.2.1 Sine-wave Filters Selection Guidelines

Sine-wave filters are selected to match the output current of the frequency converter. Select a filter that matches the overload rating (LO, HO1, or HO2) selected for the application and supply voltage.

For details on selecting and ordering a sine-wave filter, see [12.3.2.2 Sine-wave Filter OF7S1](#).

For information on filters for frames Fx09–Fx12, contact Danfoss.

For information on installing filters, see *iC7 Series Sine-wave Filter OF7S1 Installation Guide*.

## 12.3.2.2 Sine-wave Filter OF7S1

Table 106: Terminology Used in Sine-wave Filter Selection Table

Term	Description
Product code	The product code of the frequency converter. The product code consists of the mains voltage code and current rating code of the model code.
Overload setting	The overload setting of the frequency converter.
Rated output current	The rated output current of the frequency converter in the given voltage supply range and selected overload capability.
Rated current	The rated current of the filter in the given voltage supply range, 0–70 Hz motor frequency.
Code no.	Code number of the sine-wave filter that matches the frequency converter operating conditions. Protection ratings are IP00 or IP20 and UL Open Type. An optional IP21/UL Type 1 upgrade kit is available.
Frame	The frame designation of the filter, which is also used as the reference in mechanical drawings.

Table 107: Selection Table for Sine-wave Filter OF7S1

Frequency converter			Sine-wave Filter						
Product code	Overload rating	Rated output current		Rated current		IP00/UL Open Type		IP20/UL Open Type <sup>(1)</sup>	
		380–440 V [A]	441–500 V [A]	380–440 V [A]	441–500 V [A]	Code no.	Frame	Code no.	Frame
05-01A3	LO	1.3	1.2	2.4	2.1	132H4239	S1C02	132H5070	S1A02
	HO1	1.3	1.2	2.4	2.1	132H4239	S1C02	132H5070	S1A02
	HO2	0.9	0.8	2.4	2.1	132H4239	S1C02	132H5070	S1A02
05-01A8	LO	1.8	1.6	2.4	2.1	132H4239	S1C02	132H5070	S1A02
	HO1	1.8	1.6	2.4	2.1	132H4239	S1C02	132H5070	S1A02
	HO2	1.3	1.1	2.4	2.1	132H4239	S1C02	132H5070	S1A02
05-02A4	LO	2.4	2.1	2.4	2.1	132H4239	S1C02	132H5070	S1A02
	HO1	2.4	2.1	2.4	2.1	132H4239	S1C02	132H5070	S1A02
	HO2	1.8	1.6	2.4	2.1	132H4239	S1C02	132H5070	S1A02
05-03A0	LO	3.0	2.1	4.0	3.4	132H5061	S1C02	132H5061	S1A02
	HO1	3.0	2.7	4.0	3.4	132H5061	S1C02	132H5061	S1A02
	HO2	2.4	2.1	4.0	3.4	132H5061	S1C02	132H5061	S1A02
05-04A0	LO	4.0	3.4	4.0	3.4	132H5061	S1C02	132H5061	S1A02
	HO1	4.0	3.4	4.0	3.4	132H5061	S1C02	132H5061	S1A02
	HO2	3.4	3.0	4.0	3.4	132H5061	S1C02	132H5061	S1A02



Table 107: Selection Table for Sine-wave Filter OF7S1 (continued)

Frequency converter			Sine-wave Filter						
Product code	Overload rating	Rated output current		Rated current		IP00/UL Open Type		IP20/UL Open Type <sup>(1)</sup>	
		380–440 V [A]	441–500 V [A]	380–440 V [A]	441–500 V [A]	Code no.	Frame	Code no.	Frame
05-05A6	LO	5.6	4.8	7.2	6.3	132H5062	S1C02	132H5072	S1A02
	HO1	5.6	4.8	7.2	6.3	132H5062	S1C02	132H5072	S1A02
	HO2	4.3	3.4	7.2	6.3	132H5062	S1C02	132H5072	S1A02
05-07A2	LO	7.2	6.3	7.2	6.3	132H5062	S1C02	132H5072	S1A02
	HO1	7.2	6.3	7.2	6.3	132H5062	S1C02	132H5072	S1A02
	HO2	5.6	4.8	7.2	6.3	132H5062	S1C02	132H5072	S1A02
05-09A2	LO	9.2	8.2	12.5	11	132H5063	S1C02	132H5073	S1A02
	HO1	9.2	8.2	12.5	11	132H5063	S1C02	132H5073	S1A02
	HO2	8	6.3	12.5	11	132H5063	S1C02	132H5073	S1A02
05-12A5	LO	12.5	11	12.5	11	132H5063	S1C02	132H5073	S1A02
	HO1	12.5	11	12.5	11	132H5063	S1C02	132H5073	S1A02
	HO2	10	7.6	12.5	11	132H5063	S1C02	132H5073	S1A02
05-16A0	LO	16	14.5	16	14.5	132H5064	S1C03	132H5074	S1A03
	HO1	16	14.5	16	14.5	132H5064	S1C03	132H5074	S1A03
	HO2	13	11	16	14.5	132H5064	S1C03	132H5074	S1A03
05-24A0	LO	24	21	31	27	132H5065	S1C04	132H5075	S1A04
	HO1	24	21	31	27	132H5065	S1C04	132H5075	S1A04
	HO2	17	14.5	31	27	132H5065	S1C04	132H5075	S1A04
05-31A0	LO	31	27	31	27	132H5065	S1C04	132H5075	S1A04
	HO1	31	27	31	27	132H5065	S1C04	132H5075	S1A04
	HO2	25	21	31	27	132H5065	S1C04	132H5075	S1A04
05-38A0	LO	38	34	43	40	132H5066	S1C05	132H5077	S1A05
	HO1	38	34	43	40	132H5066	S1C05	132H5077	S1A05
	HO2	32	27	43	40	132H5066	S1C05	132H5077	S1A05
05-43A0	LO	43	40	43	40	132H5066	S1C05	132H5077	S1A05
	HO1	43	40	43	40	132H5066	S1C05	132H5077	S1A05
	HO2	38	34	43	40	132H5066	S1C05	132H5077	S1A05
05-61A0	LO	61	55	73	66	132H5067	S1C05	132H5078	S1A06
	HO1	61	55	73	66	132H5067	S1C05	132H5078	S1A06
	HO2	46	40	73	66	132H5067	S1C05	132H5078	S1A06

Table 107: Selection Table for Sine-wave Filter OF7S1 (continued)

Frequency converter			Sine-wave Filter						
Product code	Overload rating	Rated output current		Rated current		IP00/UL Open Type		IP20/UL Open Type <sup>(1)</sup>	
		380–440 V [A]	441–500 V [A]	380–440 V [A]	441–500 V [A]	Code no.	Frame	Code no.	Frame
05-73A0	LO	73	66	73	66	132H5067	S1C05	132H5078	S1A06
	HO1	73	66	73	66	132H5067	S1C05	132H5078	S1A06
	HO2	61	55	73	66	132H5067	S1C05	132H5078	S1A06
05-90A0	LO	90	81	106	96	132H5068	S1C07	132H5080	S1A07
	HO1	90	81	106	96	132H5068	S1C07	132H5080	S1A07
	HO2	73	66	106	96	132H5068	S1C07	132H5080	S1A07
05-106A	LO	106	96	106	96	132H5068	S1C07	132H5080	S1A07
	HO1	106	96	106	96	132H5068	S1C07	132H5080	S1A07
	HO2	90	81	106	96	132H5068	S1C07	132H5080	S1A07
05-147A	LO	147	133	170	156	132H5069	S1C08	132H5081	S1A08
	HO1	147	133	170	156	132H5069	S1C08	132H5081	S1A08
	HO2	106	96	170	156	132H5069	S1C08	132H5081	S1A08
05-170A	LO	170	156	170	156	132H5069	S1C08	132H5081	S1A08
	HO1	170	156	170	156	132H5069	S1C08	132H5081	S1A08
	HO2	147	133	170	156	132H5069	S1C08	132H5081	S1A08

1) Optional IP21/UL Type 1 kit available.

### 12.3.2.3 IP21/UL Type 1 Upgrade Kits for S1A02–S1A08 Sine-wave Filters

Table 108: Selection Table for IP21/UL Type 1 Upgrade Kits

Sine-wave filter (IP20/UL Open type)		IP21/UL Type 1 accessory kits		
Code no.	Frame	Code no.	Description	Frame
132H5070	S1A02	136B2782	IP21/UL Type 1 kit - S1K02b	S1K02b
132H5071	S1A02	136B2782	IP21/UL Type 1 kit - S1K02b	S1K02b
132H5072	S1A02	136B2782	IP21/UL Type 1 kit - S1K02b	S1K02b
132H5073	S1A02	136B2782	IP21/UL Type 1 kit - S1K02b	S1K02b
132H5074	S1A03	136B2783	IP21/UL Type 1 kit - S1K03b	S1K03b

Table 108: Selection Table for IP21/UL Type 1 Upgrade Kits (continued)

Sine-wave filter (IP20/UL Open type)		IP21/UL Type 1 accessory kits		
Code no.	Frame	Code no.	Description	Frame
132H5075	S1A04	136B2784	IP21/UL Type 1 kit - S1K04b	S1K04b
132H5077	S1A05	136B2785	IP21/UL Type 1 kit - S1K05b	S1K05b
132H5078	S1A06	136B2786	IP21/UL Type 1 kit - S1K06b	S1K06b
132H5080	S1A07	136B2787	IP21/UL Type 1 kit - S1K07b	S1K07b
132H5081	S1A08	136B2788	IP21/UL Type 1 kit - S1K08b	S1K08b

## 12.4 Ordering Options and Accessories

Table 109: Code Numbers for Ordering Options and Accessories

Category	Part name	Compatibility	Code no.
Control panel options and accessories	Blind Panel OPX00	Fx02–Fx08	136B2055
	Control Panel 2.8 OPX20	Fx02–Fx12	136B3128
	Control panel flush mounting kit	Fx02–Fx12	136B2082
	Control panel surface mounting kit	Fx02–Fx12	136B2083
	Control panel cable – 2.5 m	Fx02–Fx12	136B2084
	Control panel cable – 5 m	Fx02–Fx12	136B2085
	Control panel cable – 10 m	Fx02–Fx12	136B2086
Functional extensions	General Purpose I/O OC7C0	Fx02–Fx12	136B1568
	Relay Option OC7R0	Fx02–Fx12	136B1567
	Encoder/Resolver Option OC7M0	Fx02–Fx12	136B1569
	Temperature Measurement OC7T0	Fx02–Fx12	181B6143
Cooling kits for Rittal TS8 and VX25 enclosures	In-bottom/out-top cooling kit, FA09	FA09	176F4038
	In-bottom/out-back cooling kit, FA09	FA09	176F4040
	In-back/out-top cooling kit, FA09	FA09	176F4042
	In-back/out-back cooling kit, FA09	FA09	176F4045
	In-back/out-back cooling kit, FK09a/FB09a	FK09a/FB09a	176F4184
	In-back/out-back cooling kit, FK09c/FB09c	FK09c/FB09c	176F4190
	In-bottom/out-top cooling kit, FA10	FA10	176F4039

Table 109: Code Numbers for Ordering Options and Accessories (continued)

Category	Part name	Compatibility	Code no.
	In-bottom/out-back cooling kit, FA10	FA10	176F4041
	In-back/out-top cooling kit, FA10	FA10	176F4043
	In-back/out-back cooling kit, FA10	FA10	176F4046
	In-back/out-back cooling kit, FK10a/FB10a	FK10a/FB10a	176F4185
	In-back/out-back cooling kit, FK10c/FB10c	FK10c/FB10c	176F4191
	In-bottom/out-top cooling kit for FA11 frequency converters – 600 mm cabinet	FA11	176F4047
	In-bottom/out-top cooling kit for FA11 frequency converters – 800 mm cabinet	FA11	176F4192
	In-bottom/out-back cooling kit for FA11 frequency converters – 600 mm cabinet	FA11	176F4059
	In-bottom/out-back cooling kit for FA11 frequency converters – 800 mm cabinet	FA11	176F4193
	In-back/out-top cooling kit for FA11 frequency converters	FA11	176F4061
	In-back/out-back cooling kit for FA11 frequency converters	FA11	176F4057
	In-bottom/out-top cooling kit for FA12 frequency converters	FA12	176F4048
	In-bottom/out-back cooling kit for FA12 frequency converters	FA12	176F4060
	In-back/out-top cooling kit for FA12 frequency converters	FA12	176F4062
	In-back/out-back cooling kit for FA12 frequency converters	FA12	176F4058
<b>Pedestal kits</b>	400 mm Pedestal kit for FK09a/FB09a frequency converters	FK09a/FB09a	176F4034
	200 mm Pedestal kit for FK09c/FB09c frequency converters	FK09c/FB09c	176F4036
	400 mm Pedestal kit for FK10a/FB10a frequency converters	FK10a/FB10a	176F4035
	400 mm Pedestal kit for FK11/FB11 frequency converters	FK11/FB11	176F4044
	400 mm Pedestal kit for FK12/FB12 frequency converters	FK12/FB12	176F4037
<b>Common mode core kits</b>	HF Common mode core kit, FK09a/FB09a	FK09a/FB09a	176F4174
	HF Common mode core kit, FK10a/FB10a	FK10a/FB10a	176F4175
	HF Common mode core kit, FK11/FB11	FK11/FB11	176F4176
	HF Common mode core kit for FK12/FB12	FK12/FB12	176F4177
<b>Touch protection kits</b>	Touch protection kit, FK09a/FB09a	FK09a/FB09a	176F4164
	Touch protection kit, FK09c/FB09c	FK09c/FB09c	176F4163
	Touch protection kit, FK10a/FB10a	FK10a/FB10a	176F4161
	Touch protection kit, FK10c/FB10c	FK10c/FB10c	176F4162
	Touch protection kit, FK11/FB11	FK11/FB11	176F4132
	Touch protection kit, FK12/FB12	FK12/FB12	176F4135

**Table 109: Code Numbers for Ordering Options and Accessories** (continued)

Category	Part name	Compatibility	Code no.
Ground bar kits	Ground bar kit, FK09a/FB09a <sup>(1)</sup>	FK09a/FB09a	176F4170
	Ground bar kit, FK09c/FB09c	FK09c/FB09c	176F4186
	Ground bar kit, FK10a/FB10a <sup>(1)</sup>	FK10a/FB10a	176F4171
	Ground bar kit, FK10c/FB10c	FK10c/FB10c	176F4187
	Ground bar kit for FK11/FB11, FK12/FB12 <sup>(2)</sup>	FK11/FB11, FK12/ FB12	176F4188
Multi-wire kits	Multi-wire kit, Fx09–Fx10	Fx09-Fx10	176F4189

1) If a common-mode filter kit is used, it is not possible to use a ground bar kit.

2) If a common-mode filter kit is used, components of the ground bar kit cannot be installed for the output side.

## 12.5 Ordering Self-service Parts

Parts that may need to be replaced during the lifetime of the drive are available as spare parts. Available self-service parts are listed in [Table 110](#). For other parts, contact Danfoss. A list of available spare parts for products can also be found at <https://www.danfoss.com>.

**Table 110: List of Self-service Parts**

Part type	Part name	Used in	Code number
Control covers	Terminal cover iC7 FA02a	FA02a	136B2056
	Terminal cover iC7 FA02b	FA02b	136B2059
	Terminal cover iC7 FA03a	FA03a	136B2057
	Terminal cover iC7 FA03b	FA03b	136B2060
	Terminal cover iC7 FA04a-FA05a	FA04a, FA05a	136B2058
	Terminal cover iC7 FA04b-FA05b	FA04b, FA05b	136B2061
	Side cover FA03a	FA03a	136B2066
	Side cover FA03b	FA03b	136B2069
	Side cover FA04a	FA04a	136B2067
	Side cover FA04b	FA04b	136B2070
	Side cover FA05a	FA05a	136B2068
	Side cover FA05b	FA05b	136B2071
Control panel cradles	Control panel cradle FA02a	FA02a	136B2062
	Control panel cradle FA02b	FA02b	136B2064
	Control panel cradle FA03a-FA05a	FA03a-FA05a	136B2063
	Control panel cradle FA03b-FA05b	FA03b-FA05b	136B2065
	Control panel cradle Fx06-Fx08	Fx06-Fx08	136B2943

Table 110: List of Self-service Parts (continued)

Part type	Part name	Used in	Code number
<b>Control connectors</b>	Control board connectors (X31, X32, X61)	Control board	136B1927
	I/O connectors (X11, X12, X101, X102)	Basic I/O board	136B1924
	I/O connectors (X101, X102, X103)	Relay Option OC7R0	136B3162
	I/O connector (X14)	General Purpose I/ O OC7C0	136B3160
	I/O connector (X15)	Encoder/Resolver Option OC7M0	136B3161
	I/O connector (X54)	Temperature Mea- surement OC7T0	Contact Danfoss.
	Option connector	Options	136B1570
<b>Power connectors</b>	Power connectors FA02-FA03	FA02, FA03	136B2072
	Power connectors FA04	FA04	136B2073
	Power connectors FA05	FA05	136B2074
<b>Input plates</b>	Input plate FK06	FK06	136B2939
	Input plate FK07	FK07	136B2940
	Input plate FK08	FK08	136B2941
<b>EMC plates</b>	Power connectors and EMC plate FA02- FA03	FA02-FA03	136B1921
	Power connectors and EMC plate FA04	FA04	136B1922
	Power connectors and EMC plate FA05	FA05	136B1923
	EMC plate FA06	FA06	136B3507
	EMC plate FA07	FA07	136B3508
	EMC plate FA08	FA08	136B3509
<b>Control EMC plates</b>	EMC plate Slot A	Fx02–Fx12	136B2076
	EMC plate Slot B	FA02–FA05	136B1925
	EMC plate Slot C-E	Fx03–Fx12	136B1928
	Fieldbus EMC plate FA02-FA08	FA02–FA08	136B1926
	Fieldbus EMC plate FA09-FA12	FA09–FA12	176F3529

Table 110: List of Self-service Parts (continued)

Part type	Part name	Used in	Code number
Fans	Main fan FA02	FA02	136B2077
	Main fan FA03	FA03	136B2078
	Main fan FA04	FA04	136B2079
	Main fan FA05	FA05	136B2080
Door filter	Door filter for FK09-FK12/FB09-FB12	FK09-FK12/FB09-FB12	176F3353







**Danfoss A/S**  
Ulsnaes 1  
DK-6300 Graasten  
[drives.danfoss.com](http://drives.danfoss.com)

Any information, including, but not limited to information on selection of product, its application or use, product design, weight, dimensions, capacity or any other technical data in product manuals, catalog descriptions, advertisements, etc. and whether made available in writing, orally, electronically, online or via download, shall be considered informative, and is only binding if and to the extent, explicit reference is made in a quotation or order confirmation. Danfoss cannot accept any responsibility for possible errors in catalogs, brochures, videos and other material. Danfoss reserves the right to alter its products without notice. This also applies to products ordered but not delivered provided that such alterations can be made without changes to form, fit or function of the product. All trademarks in this material are property of Danfoss A/S or Danfoss group companies. Danfoss and the Danfoss logo are trademarks of Danfoss A/S. All rights reserved.

M00271

