

ENGINEERING  
TOMORROW

*Danfoss*

Operator's Manual

# ET4500-002 Crimping Machine

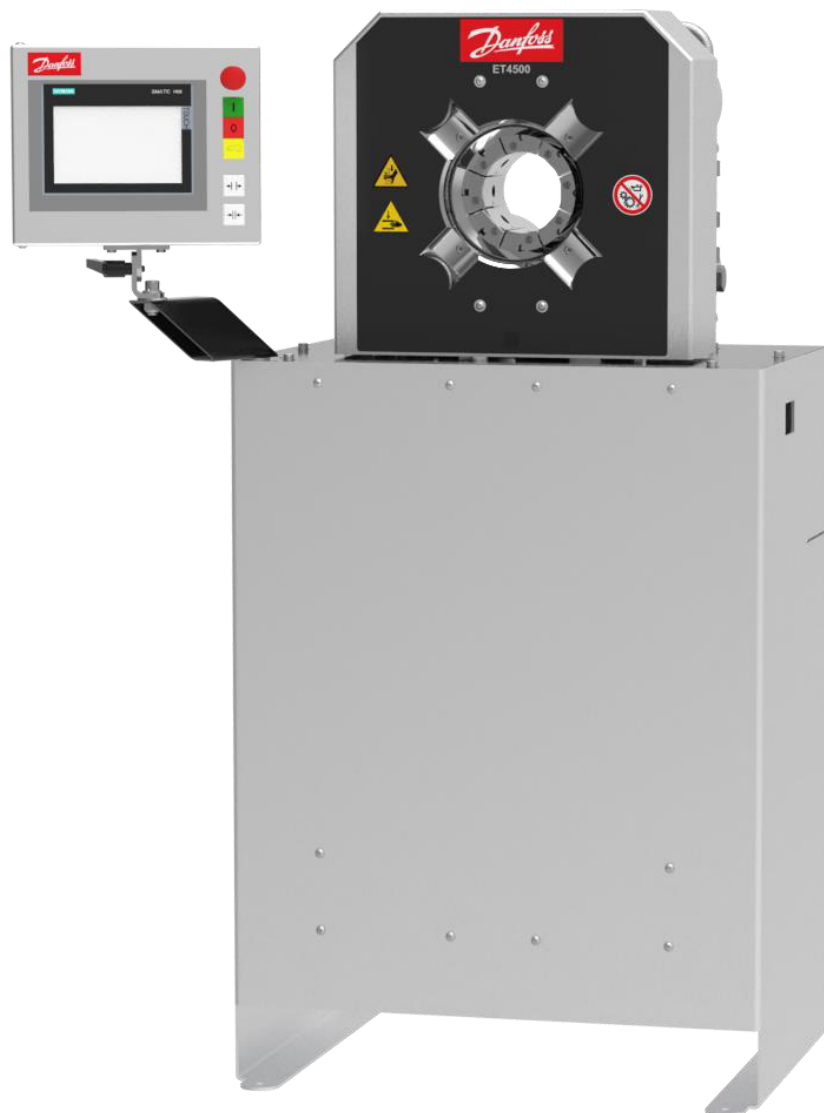

## Imprint

**Manufacturer:**

UNIFLEX-Hydraulik GmbH  
Robert-Bosch-Strasse 50-52  
D-61184 Karben  
Germany

Phone: +49 (0) 60 39 / 91 71 - 0  
Fax: +49 (0) 60 39 / 91 71 - 181

**This Operating Manual of the machine is a translation; the original is in German.**

**Date of revision: 2024-07-22**

**Version: 1.1**

© Copyright by UNIFLEX-Hydraulik GmbH

Technical modifications reserved.

The reproduction, distribution and utilization of this document as well as the communication of its contents to others without explicit authorization are prohibited. Offenders will be held liable for the payment of damages. All rights reserved in the event of the grant of a patent, utility model or design.

## EC / UK - Declaration of Conformity

In accordance with EC Machinery Directive 2006/42/EC and UK-Supply of Machinery (Safety) Regulations 2008.

The following machine

ET4500-002

was developed, designed and manufactured in compliance with EC Directive 2006/42/EC and UK-Supply of Machinery (Safety) Regulations 2008, in the sole responsibility of

UNIFLEX-Hydraulik GmbH  
Robert-Bosch-Strasse 50 - 52  
D-61184 Karben

The following standards, codes and specifications have been applied:

- EC Directive 2006/42/EC
- EMC Directive 2014/30/EC
- EN ISO 12100: 2010
- EN 60204-1: 2018
- UK-Supply of Machinery (Safety) Regulations 2008
- UK-Electromagnetic Compatibility Regulations 2016

This declaration are invalid when the machine is modified or if unauthorized and unapproved third-party components are used without our prior approval.

Entity authorised for documentation: Uniflex-Hydraulik GmbH, Technical Documentation Dept.

Karben, 28.09.2022



Managing Director Harald von Waitz

# Contents

<b>1</b>	<b>About this document</b> .....	<b>7</b>
1.1	Target groups .....	7
1.2	Storage .....	9
1.3	Name plate .....	9
<b>2</b>	<b>Safety instructions</b> .....	<b>10</b>
2.1	Presentation of warnings .....	10
2.2	Intended use .....	10
2.3	Product-specific risks .....	11
2.3.1	Risks imposed by mechanical equipment .....	12
2.3.2	Risks imposed by electricity .....	12
2.3.3	Risks imposed by hydraulic equipment .....	12
2.3.4	Risks imposed by noise .....	13
2.3.5	Risks imposed by substances .....	13
2.3.6	Risk by hot surfaces .....	13
2.3.7	Risks in case of fire .....	13
2.4	Safety .....	14
2.4.1	Working area .....	14
2.4.2	Emergency-stop button .....	14
2.4.3	Protection equipment .....	15
2.4.4	Warning signs on the machine .....	16
<b>3</b>	<b>Machine description</b> .....	<b>17</b>
3.1	Design and function .....	17
3.2	Forming process .....	19
3.3	Operation and display elements C.2 .....	20
3.4	Electric sockets .....	22
3.5	Foot pedal (accessory) .....	22
3.6	Depth stop (accessory) .....	23
3.7	Operation modes .....	23
3.8	Technical data .....	26
<b>4</b>	<b>Transport and commissioning</b> .....	<b>29</b>
4.1	Transport .....	29
4.2	Intermediate storage of machine/unit .....	30
4.3	Commissioning .....	30

## Contents

---

4.3.1	Filling hydraulic oil .....	31
4.3.2	Electrical connection .....	33
4.3.3	Bleeding the hydraulic system .....	36
<b>5</b>	<b>Operation .....</b>	<b>37</b>
5.1	What you have to observe .....	37
5.2	Activation .....	37
5.3	Forming the workpiece.....	38
5.3.1	Prerequisites.....	38
5.3.2	Remote automatic mode, via dual foot switch .....	38
5.3.3	Operation mode buttons control panel.....	40
5.3.4	Remote automatic mode, via depth stop .....	41
5.4	Changing the crimping dies .....	42
5.4.1	Changing the crimping dies using a die wrench .....	42
5.5	Replacing the intermediate dies.....	44
5.5.1	Changing the crimping dies with the quick die change system (only profile 239).....	47
5.6	Depth stop (accessory).....	49
5.7	Setting the forming dimension .....	50
5.8	Forming travel limitation .....	50
5.9	Stop .....	51
5.10	Emergency stop.....	52
5.11	Cleaning.....	52
<b>6</b>	<b>Maintenance.....</b>	<b>54</b>
6.1	What you have to observe .....	54
6.2	Maintenance schedule.....	54
6.3	Hydraulic oil change.....	56
6.4	Checking and replacing slide bearing plates.....	58
<b>7</b>	<b>Troubleshooting .....</b>	<b>60</b>
<b>8</b>	<b>Decommissioning, disposal .....</b>	<b>61</b>
8.1	Dismantling .....	62
8.2	Recycling .....	62
8.3	Consumables and waste.....	62
<b>9</b>	<b>Annex .....</b>	<b>63</b>
9.1	Accessories (retrofitable) .....	64
9.2	Spare parts list.....	65
9.2.1	Tool.....	65

## Contents

---

9.2.2	Basic dies .....	66
9.2.3	Mechanical equipment .....	67
9.2.4	Hydraulic system .....	68
9.2.5	Electric equipment.....	70
9.3	Spare parts kit .....	72
9.4	Service tool.....	73
9.5	Retaining bolt for standard crimping dies (depending on crimping die) .....	74
9.6	Hydraulic diagram.....	76
9.7	Electric diagram.....	76
9.8	Maintenance log .....	84
9.9	Declaration of qualified staff .....	85

## 1 About this document

### 1.1 Target groups

---

# 1 About this document

In this Operation Manual, the “forming machine ET4500-002” is consistently referred to as machine.

This Operation Manual includes important notes on how you operate your machine/unit safely, properly and economically.

Use not in compliance with the intended purpose may result in hazard to the operator's health and life and/or in the risk of damage to/the machine/unit. Consequently, please only use the machine/unit

- in good order and condition,
- in accordance with its intended purpose,
- in a safety-conscious manner, with awareness of risks and hazards,
- in compliance with all notes included in this Operation Manual.

The machine/unit may only be operated by staff who

- has read the Operation Manual,
- has understood it,
- has been instructed in the operation of the machine/unit, and
- has signed in the Annex.



Figures may include accessories/options. Customer-specific equipment may vary.

The product images shown are for reference only and may differ from the product delivered.

### 1.1 Target groups

The target groups of this Operation Manual are:

#### **Owner**

An owner is a natural person or entity using the device himself/herself/itself, or on whose behalf the device is used. An owner may appoint a representative to exercise the owner's rights and obligations.

The owner has to make sure that

# 1 About this document

## 1.1 Target groups

---

- national provisions, occupational safety regulations and applicable environmental protection regulations are fully complied with;
- persons working on the machine/unit are adequately qualified;
- persons working on the machine/unit are suitable for operating the machine/unit;
- the Operation Manual has been read and understood. One hardcopy of the Operation Manual must always be kept at a designated place where the machine/unit is used.
- persons working on the machine/unit are aware of potential risks;
- the operating staff is familiar with the location as well as with operating the fire alarm and fighting means. Free access to this equipment must be ensured.
- personal protection equipment is worn (safety footwear, protection gloves and safety glasses).

### **Machine/unit fitters**

Machine/unit fitters must be at least 18 years old and have completed training for the task, i.e. they must have attended a specialist vocational training.

#### A fitter

- must observe the instructions in the Operation Manual;
- must inform the owner on failures and damage.

### **Operator**

An operator is a person charged with and instructed in the proper operation of the machine/unit by the owner or the otherwise contractually obliged person.

#### The operator

- must observe the instructions in the Operation Manual;
- must inform the owner on failures and damage.
- must not perform and maintenance or repair work on the machine/unit.



# 1 About this document

## 1.2 Storage

---

### 1.2 Storage

The Operation Manual is part of the machine/unit and must be kept near the machine/unit at all times. Upon disposal of the machine/unit, the Operation Manual must also be handed over.

### 1.3 Name plate

The name plate is fixed near the power cable.

## 2 Safety instructions

### 2.1 Presentation of warnings

Warning notes in the Operation Manual warn against risks involved with the handling of the machine/unit. Risk levels are identified as follows:

**HAZARD!**

The signal word HAZARD identifies an imminent hazard resulting in serious injuries or death. This warning is supplemented by a triangular hazard symbol.

**WARNING!**

The signal word WARNING identifies a potentially hazardous situation, which might result in serious injuries or death. This warning is supplemented by a triangular hazard symbol.

**CAUTION!**

The signal word CAUTION identifies a potentially hazardous situation, which might result in light injuries. This warning is supplemented by a triangular hazard symbol.

**ATTENTION!**

The signal word ATTENTION identifies a potentially hazardous situation, in which the product or property in the environment may be damaged. This warning is supplemented by a hazard symbol or an exclamation mark.

### 2.2 Intended use

This machine is a forming machine for industrial use, only suitable for the manufacture of hose connections with a permissible diameter depending on the fitting and the hose thickness, see “Technical Data” in Section 3.

Intended purposes include:

- single workplace for one person only,
- single stroke with manual feed and withdrawal,
- for maximum hydraulic operating pressure, see “Technical Data” in Section 3.
- operating temperature between 10 °C and 35 °C,
- operation in a closed room,
- use of eight identical original UNIFLEX dies with the same label or seven dies and one associated marking crimping die.

## 2 Safety instructions

### 2.3 Product-specific risks

---

- The machine must not be operated by persons not capable of operating the machine without any risk. These may include:
  - persons with physical or mental disabilities;
  - children and persons under age;
  - persons with a restricted capability for the operation of machines (e.g. under the influence of drugs, alcohol or narcotics)

Use of the control in compliance with the intended purpose also includes compliance with the instructions in this Operation Manual.

#### **Use for other than the intended purpose**

Any other use is considered as being not in compliance with the intended purpose, in particular:

- design modification of the machine;
- use in explosive environments;
- forming of non-metal workpieces without specific safeguards approved by UNIFLEX;
- misuse of consumables and waste materials.

In particular non-metal workpieces may be overstressed by the forming process so that this may result in a sudden failure. Chips or seriously accelerated workpiece parts impose a high risk potential for operators, individuals and objects, even outside the working area.

#### **WARNING!**



#### **Risk for life and health!**

Use not in compliance with the intended purpose imposes risks for life and health. Consequences resulting from use for other than the intended purpose shall be under the sole responsibility of the owner.

- Always use the machine in compliance with its intended purpose.

### 2.3 Product-specific risks

The machine/unit is designed in accordance with the latest state of technology. Nevertheless, the machine/unit may impose risks:

---

## 2 Safety instructions

### 2.3 Product-specific risks

---

#### 2.3.1 Risks imposed by mechanical equipment

##### **Risk of squeezing**

When the die system closes, there is a risk of getting squeezed between the die and the workpiece.

- Keep the feed opening for the workpiece as small as possible.
- Keep sufficient distance to the die system.

##### **Tilting hazard**

The risk of tilting mainly exists while the machine is being transported.

- Observe the machine's centre of gravity during transport.

#### 2.3.2 Risks imposed by electricity

There is a risk of electrocution near the live parts!

- Work on electric systems may only be performed by qualified electricians or instructed and trained persons under the supervision of a qualified electrician.
- Deactivate the machine/unit and secure it against unintentional restart before maintenance.

#### 2.3.3 Risks imposed by hydraulic equipment

Risks are imposed by all hydraulic lines and connections. Hydraulic systems are subject to special safety provisions. Work on hydraulic equipment may only be performed by persons with expert knowledge of and experience with hydraulic equipment.

- After the machine/unit is deactivated, the given and potentially hazardous residual energy has to be considered.
- Relieve the residual pressure in the system before performing repair or maintenance work on hydraulic systems.
- Regularly check lines and bolted connections for leaks and visible damage. Immediately remedy any damage detected.

Repair work on the hydraulic system of the machine/unit or on its components may only be performed by UNIFLEX specialist staff.

## 2 Safety instructions

### 2.3 Product-specific risks

---

#### 2.3.4 Risks imposed by noise

The noise level meter acc. to IEC 804, Class 2, was calibrated before measuring.

The operation of the machine/unit causes noise emissions of < 70 dB(A) at the workplace. Noise protection is not required.

Higher noise emissions may occur when other machine/unit is simultaneously used at the workplace. The machine/unit owner must provide for appropriate protection, e.g.

- instruct staff to wear ear protection,
- provide information/instructions on risks,
- identify hazardous areas,
- provide health monitoring.

#### 2.3.5 Risks imposed by substances

Oils, greases and emulsions may penetrate the skin. When handling hazardous substances, oils and greases, the manufacturers' safety instructions have to be observed. Apply skin protection appropriate for the hazardous substances used.

#### 2.3.6 Risk by hot surfaces

There is a risk of burning when the electric motor and/or the workpiece are touched after forming.

- Keep sufficient distance to the electric motor.
- Wear protection gloves.

#### 2.3.7 Risks in case of fire

The operating staff has to be familiar with the location as well as with operating the fire alarm and fighting means. Free access to this equipment must be ensured.

Never use water to extinguish a fire. For appropriate fire extinguishing action, please read the safety data sheet of the hydraulic oil supplier.

## 2.4 Safety

### 2.4.1 Working area

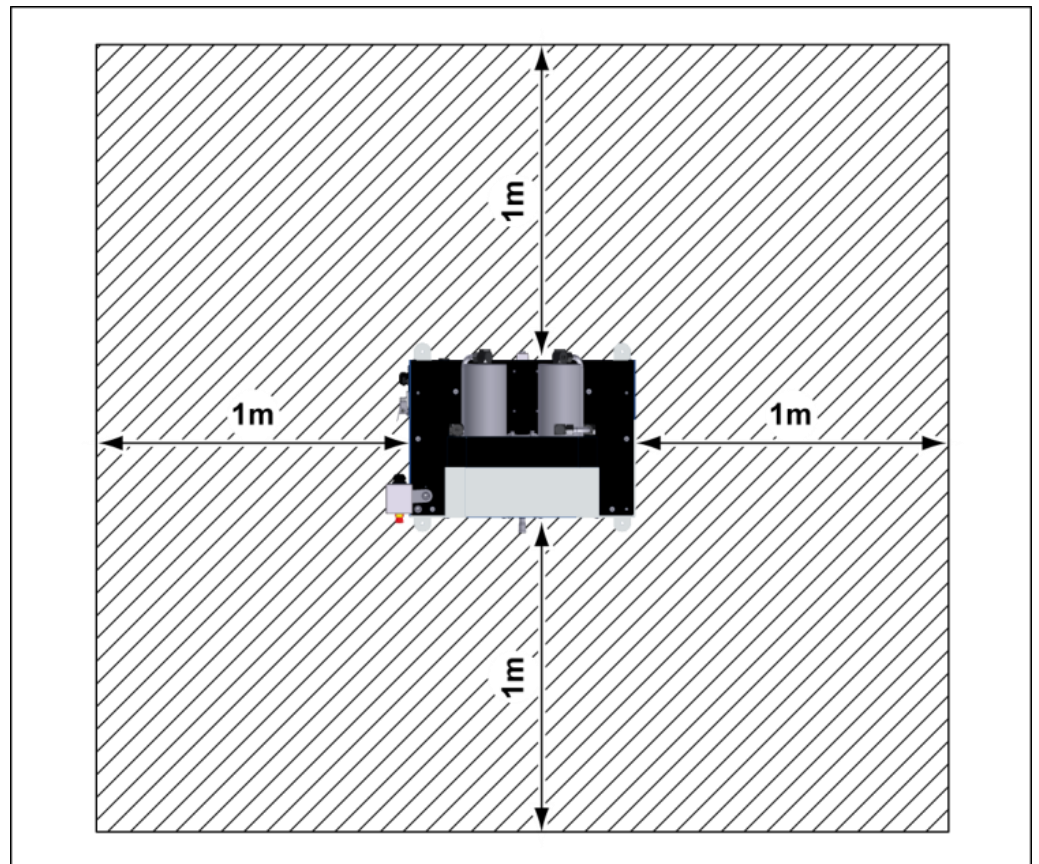

The working area is designed as the area 1 metre all around the machine (shaded).

- Keep the working area free from trip hazards
- Use ducts for lines and cables
- Provide good illumination
- Keep access to hydraulic supply free

### 2.4.2 Emergency-stop button

The machine is fitted with an emergency-stop button on the control panel.

## 2 Safety instructions

### 2.4 Safety

---

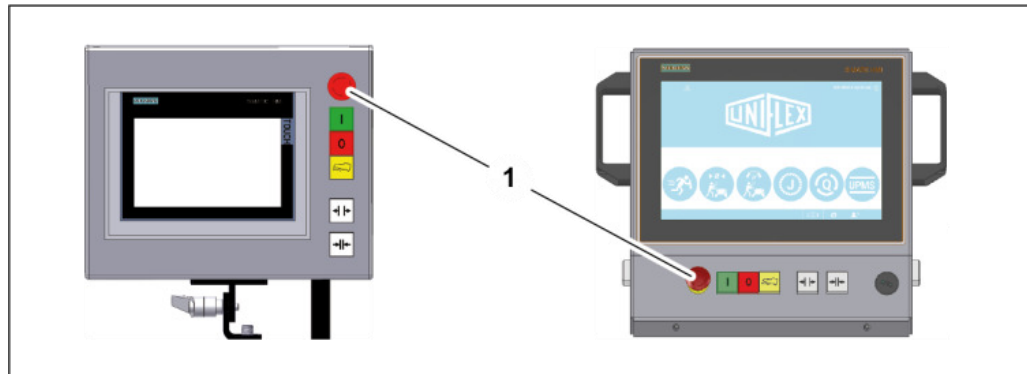

Immediately activate the emergency-stop button (1) in cases of emergency.

Remedy the cause of the emergency stop first before unlocking the emergency-stop button.

Do not pull the emergency-stop button for unlocking it, but release it by rotating it.

#### 2.4.3 Protection equipment

Due to the variety of customer-specific workpieces, UNIFLEX is not capable of supplying additional standard protection equipment together with the machine for the prevention of potential residual risks imposed by the machine.

The necessity of additional, workpiece-specific protection equipment may for instance arise for angled workpiece geometries needing a large opening for being inserted into the forming machine. The pressure joining of insulators, structural steel and steel ropes, too, may require special safeguards.

The owner has to consider the need for adapted protection equipment before commissioning. If such need exists, the relevant protection equipment has to be mounted before commissioning of the machine.

UNIFLEX will provide you with customized solutions for protection equipment upon request. Please do not hesitate to address your personal contact for consultation.



Mounted safety equipment must not be removed, bypassed or avoided.

## 2 Safety instructions

### 2.4 Safety

#### 2.4.4 Warning signs on the machine



	<b>Hand injury</b> on the die system
	<b>Risk of squeezing</b> on the die system
	<b>Oiling / greasing prohibited</b> on the die system

Illegible or missing warning signs must immediately be replaced by the owner.



## 3 Machine description

### 3.1 Design and function

#### Basic machine

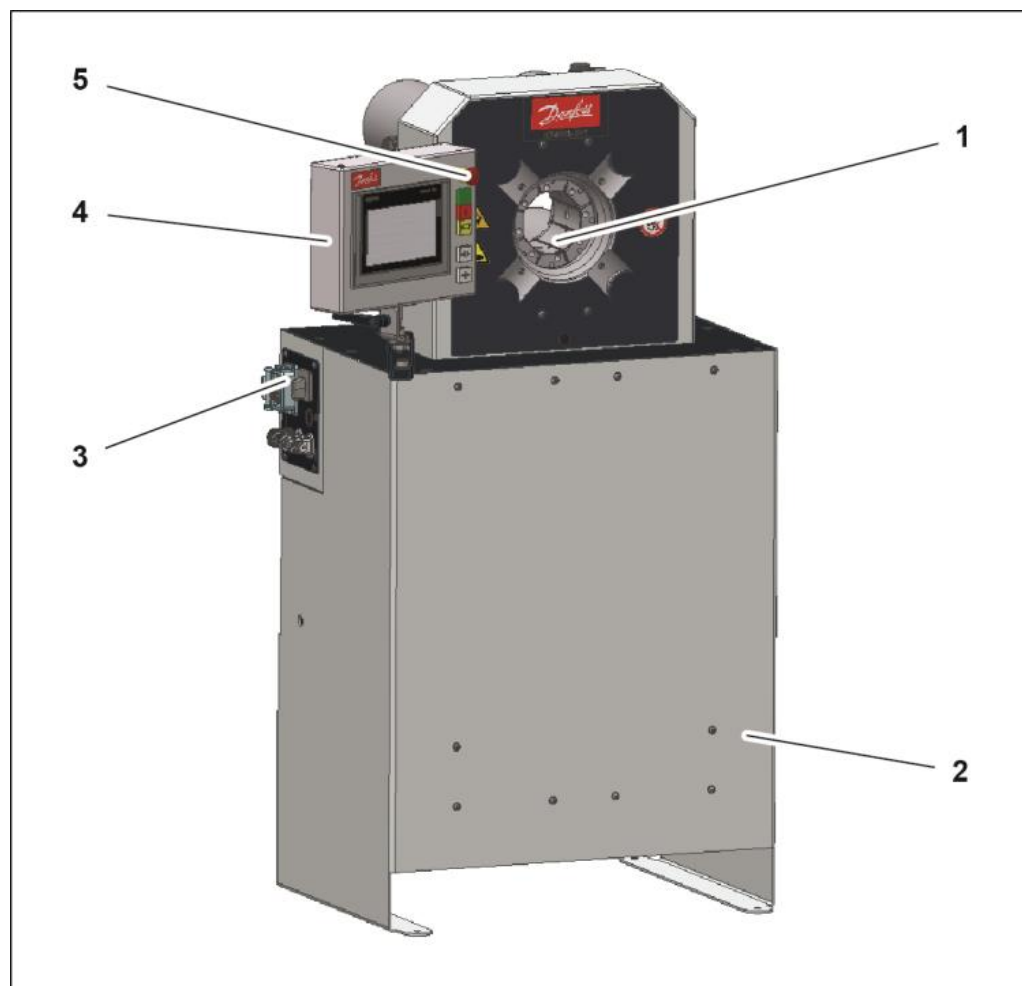

- (1) Crimping tool
- (2) Hydraulic tank (with electric motor, pump)
- (3) Main power switch
- (4) Control panel with buttons and control system CONTROL C.2 / IPC
- (5) Emergency-stop button

The crimping tool (1) is closed hydraulically, whereby the workpiece is formed. The pressure needed for this purpose is built up by the electrically driven pump (2) in the cylinders.

## 3 Machine description

### 3.1 Design and function

---

The position encoder system records the current position of the die system and transfers the value to the control system.

Data records may be saved in the item memory and recalled at any time in the control system. Depending on the operation mode, the actual forming process is controlled via the buttons on the control panel (4), the depth stop or the dual foot switch.

#### Crimping tool

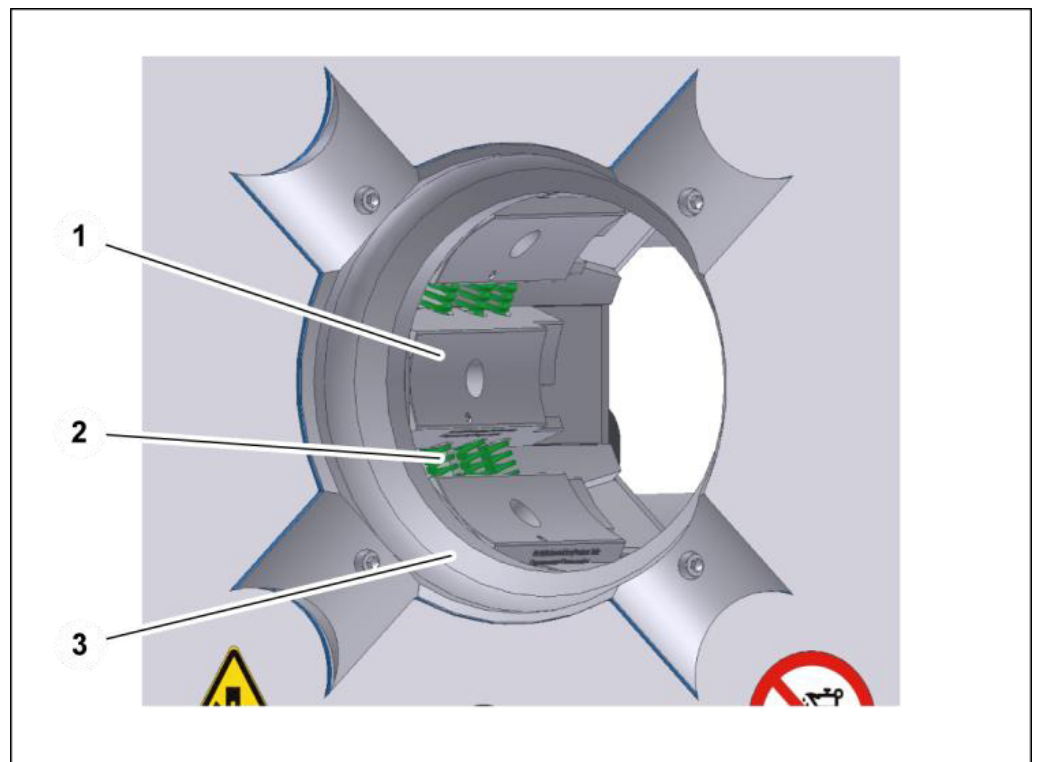

The die system comprises basic dies, intermediate dies (depending on the application) and crimping dies.

All basic dies are supported on slide plate. The crimping dies and the intermediate dies, if any, are placed on the basic dies (1). The intermediate dies are needed, if small workpieces are to be formed on a large machine.

After the forming process, the basic dies are pressed apart by the springs (2) when the tool opens. The bearing segments (3) on the front guide the basic dies axially in the tool.

#### Accessories

The machine may be fitted with accessories. A list of the available accessories is included in the Annex, Section "Accessories".

## 3.2 Forming process

There are two types of forming process with different target parameters:

- Forming to a defined diameter
- Forming to a defined pressure

### **Forming to a defined diameter**

This is the standard process for forming to produce hydraulic hoses. The crimping tool closes until it reaches a pre-set diameter, regardless of the required forming force. The required forming force may be up to the machine's maximum capacity.

Optionally, it is possible to monitor the required forming pressure (= forming force) at the time when the pre-set diameter is reached, in order to detect workpiece deviations (PFM option: Pressure Force Monitoring).

### **Forming to a defined pressure**

This process is used for special applications, e.g. insulators with a fibreglass rod, which are pressure-sensitive. Due to the workpiece tolerances, forming to a specific diameter could result in the destruction of the workpiece. The crimping tool closes until the pre-set pressure value is reached; there is no pressure control.

Optionally, it is possible to monitor the obtained forming diameter at the time when the pre-set pressure is reached, in order to detect workpiece deviations (PFM option: Pressure Force Monitoring).

Optional pressure control to the requested pre-set pressure, including the possibility to vary the pressure built-up speed and soft approach of the pre-set pressure (PFC function: Pressure Force Control).

### 3 Machine description

#### 3.3 Operation and display elements C.2

<b>WARNING!</b>	
	<p><b>Risk of injuries!</b></p> <p>In particular non-metal workpieces may be overstressed by the forming process so that this may result in a sudden failure. Chips or seriously accelerated workpiece parts impose a high risk potential for operators, individuals and objects, even outside the working area!</p> <ul style="list-style-type: none"><li>• Relevant workpieces should only be formed using specific safeguards.</li></ul>

<b>ATTENTION!</b>	
	<p><b>Risk of damage to machinery!</b></p> <p>The machine lifetime is reduced with a high permanent load, while wear increases disproportionately.</p> <ul style="list-style-type: none"><li>• When using the machine in series production, it must not permanently be loaded with over 2/3 of the maximum operating pressure.</li><li>• The especially high load during pressure joining of isolators, structural steel as well as steel ropes (PFC applications) necessitates machine overhauls after 150,000 forming processes, each. Please contact our Service department in due time: +49 (0)6039 9171-0.</li></ul>

### 3.3 Operation and display elements C.2

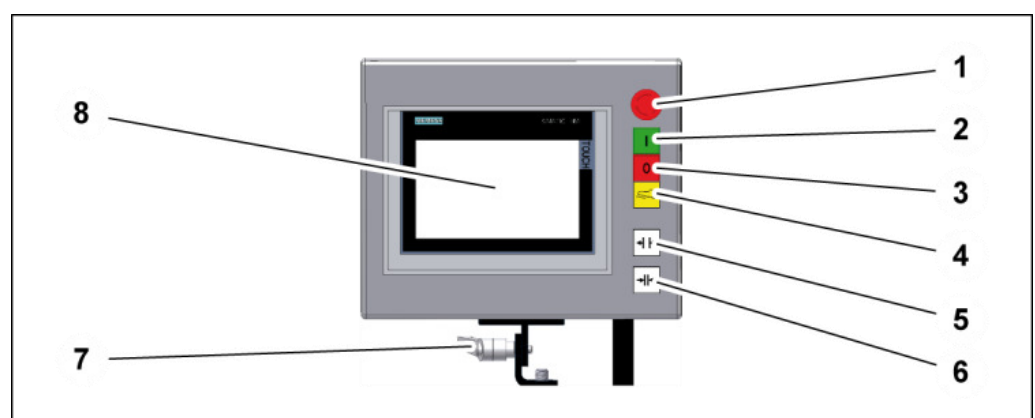

(1) Emergency-stop button

## 3 Machine description

### 3.3 Operation and display elements C.2

---

- (2) Illuminated Motor on button [I]
- (3) Motor off button [O]
- (4) Illuminated foot switch [↵]
- (5) Illuminated Open tool button [←|→]
- (6) Illuminated Close tool button [→|←]
- (7) Locking lever / angle setting
- (8) control panel of CONTROL C.2



The illuminated buttons [I] and [O] may be arranged the other way round, depending on the control version.



The operation of the control system CONTROL C.2 is described in a separate Operation Manual. This description is supplied with the machine.

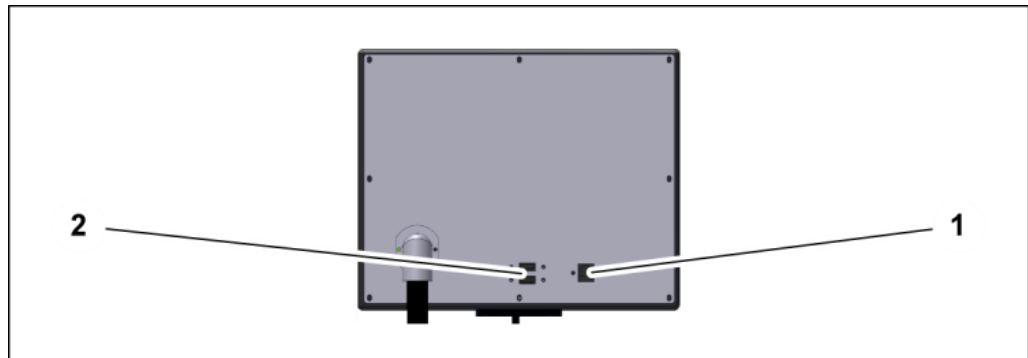

- (1) LAN socket for connection with a network. Network connection options are set out in the description of the relevant optional packages.
- (2) 2 x USB sockets (for the use of memory media, callipers or barcode scanners certified by UNIFLEX, only)

### 3 Machine description

#### 3.4 Electric sockets

#### 3.4 Electric sockets

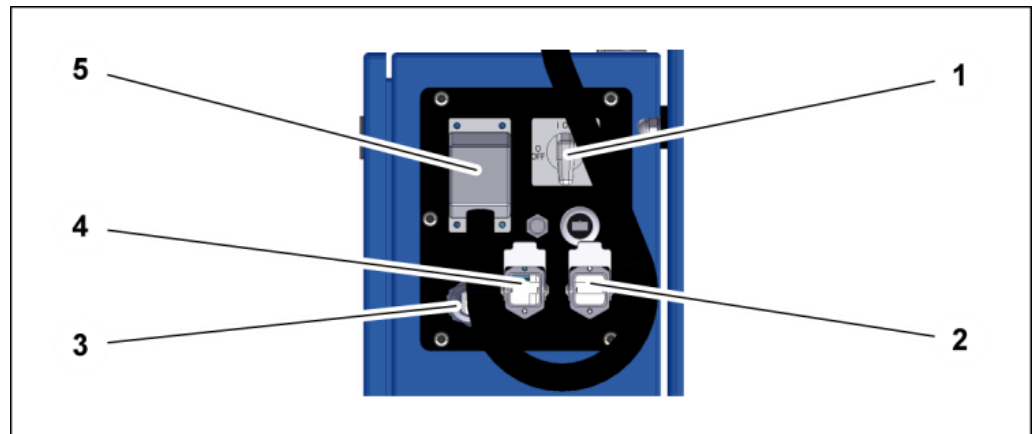

- (1) Main power switch
- (2) Socket for single foot switch
- (3) Power cable screw connection
- (4) Socket for depth stop / dual foot switch
- (5) Control panel connection

#### 3.5 Foot pedal (accessory)



- (1) Close machine pedal [→|←]
- (2) Open machine pedal [←|→]

#### WARNING!



#### Risk by fatiguing posture!

A static posture may result in work-related musculoskeletal disorders and reduce productivity.

- Make sure that operators have sufficient periods of relief and recreation.

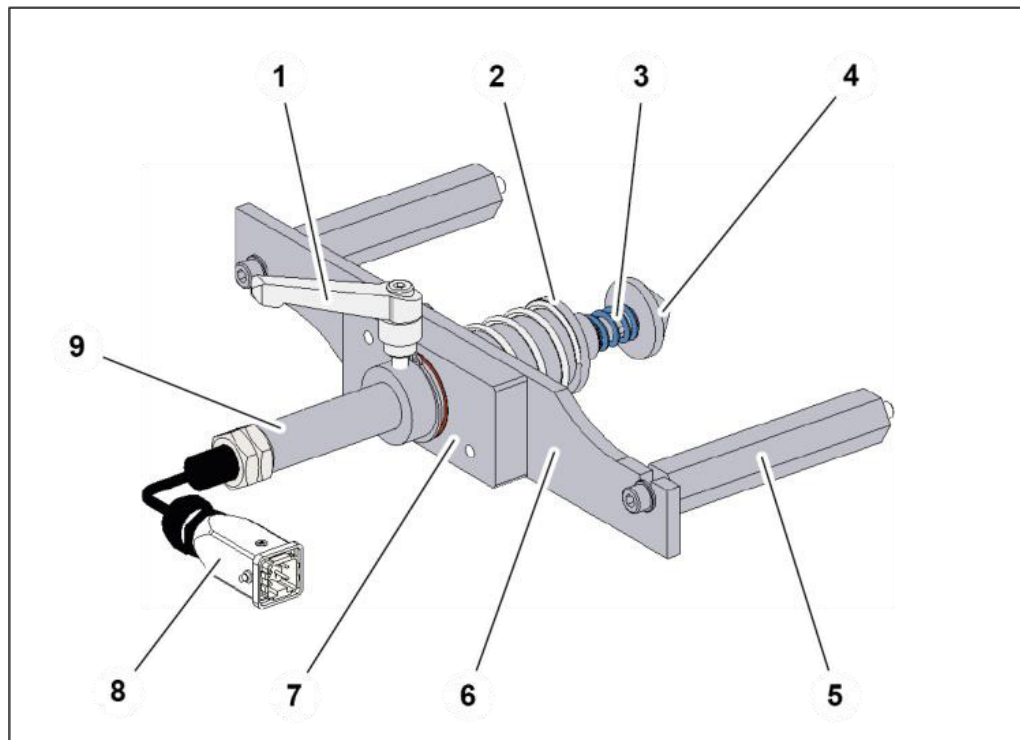

### 3.6 Depth stop (accessory)



- (1) Clamp lever
- (2) Sleeve
- (3) Plunger
- (4) Stop pin
- (5) Spacer
- (6) Clamping yoke
- (7) Guidance
- (8) Connection cable with plunger switch
- (9) Sleeve

### 3.7 Operation modes

The control unit provides for the following operation modes for operating the forming tool:

- Manual operation  
C.2  / IPC  is activated in the control. The forming

## 3 Machine description

### 3.7 Operation modes



---

process is controlled manually via the buttons on the control panel or external buttons (depth stop or dual foot switch):

- Activate the [→|←] button for closing and forming. The [←|→] button is used for opening.
- Dual foot switch  
The right foot switch is used for closing and forming. The left foot switch is used for opening.
- Depth stop  
The tool is closed automatically when the workpiece activates the depth stop by pressure. Press the [←|→] button to open the tool.

As soon as the pre-set forming diameter or forming pressure is reached in the control, the tool stops and opens automatically.

- Semi-automatic operation

C.2  / IPC  is activated in the control. The forming process is started manually via the buttons on the control panel or external buttons, e.g. the dual foot switch:

- Activate the [→|←] button for closing and forming.
- Dual foot switch  
The right foot switch is used for closing.
- Depth stop  
The tool is closed automatically when the workpiece activates the depth stop by pressure.

As soon as the forming diameter or forming pressure as defined in the control is reached, the tool stops and opens automatically after the preset holding time.

Production is possible in any operation mode.



The operation mode selected before deactivating the machine will be active upon a restart. The operation modes are set on the control panel.



When the Foot switch button  is activated, the Close tool button [→|←] is inoperative, even if the button is illuminated. The Open tool button [←|→] is always active independently.



## 3 Machine description

### 3.7 Operation modes

---



The operation of the control system is described in a separate Operation Manual. This description is supplied with the machine.

## 3 Machine description

### 3.8 Technical data

---

#### 3.8 Technical data

##### Machine

Dimensions L x W x H	745 x 600 x 1360 mm
Weight	approx. 490 kg
Control	CONTROL CONTROL C.2
Operation mode	S6-70%
Noise level	69 dB(A)*
Protection class	IP 40

##### Function

Forming force	2800 kN / 280 t
Max. forming range	Ø crimping dies + 17 mm (max. outside diameter of the fittings before the forming process)
Maximum Ø crimping dies	92 mm
Opening size without dies	147 mm
Opening distance	+45 mm
Closing speed	6,2 mm/s*
Forming speed	1,7 mm/s*
Opening speed	10,7 mm/s*

##### Work piece capacity

SAE R15 / 4SH 1 Part fittings	2", depending on the fitting
SAE R15 2 Part fittings	1 1/2", depending on the fitting
4 SH 2 Part fittings	2", depending on the fitting
Industry	3"
90° bend	2", depending on the fitting
Die type	266

## 3 Machine description

### 3.8 Technical data

---

#### Electrical connection

Voltage variant	<b>230 V 50/60 Hz, 3 phases</b> <b>380 - 420 V 50 Hz, 3 phases</b> <b>380 - 480 V 60 Hz, 3 phases</b>
Power rating	4 kW
Back-up fuse	230 V: 20 A delayed, 380 - 480 V: 16 A delayed, preferably thermal fuses, if circuit breakers are used these should be of the class C type.

#### Hydraulic system

Oil volume	approx. 70 l
Oil type	HM 46 or HLP 46, ISO 11158 / ISO 6743-4, 10 $\mu$ filtered
The oil type can be adapted for specific applications	Viscosity class 68 mm <sup>2</sup> /s for high- temperature operating conditions.  Viscosity class 32 mm <sup>2</sup> /s for low- temperature operating conditions.
System pressure	max. 330 bar

#### We recommend industrial flooring meeting the following structural requirements

Permanent floor loading	Approx. 0.07 kg/mm <sup>2</sup>
Floor carrying capacity	Min. 2500 kg/m <sup>2</sup>
Floor quality	B25
Evenness	Max. unevenness 5 mm/m
Inclination	max. 5 mm/m

## 3 Machine description

### 3.8 Technical data

---

#### Ambient conditions

Ambient temperature 10 °C – 35 °C

Air humidity 45 % – 65 %

The \* data are theoretical/computed values, or values measured on a prototype. Actual values may vary slightly, depending on the machine.



The use of special hydraulic oil with improved properties and additives can prolong the service life of the machine and extends the oil change interval.

Information and assistance for the oil analysis can be provided by you local oil supplier.

## 4 Transport and commissioning

### 4.1 Transport

## 4 Transport and commissioning

### 4.1 Transport

The goods should be transported in the original packaging. During transport, the goods must be secured safely within the packaging. All applicable laws and regulations relating to securing loads shall be observed during transport.

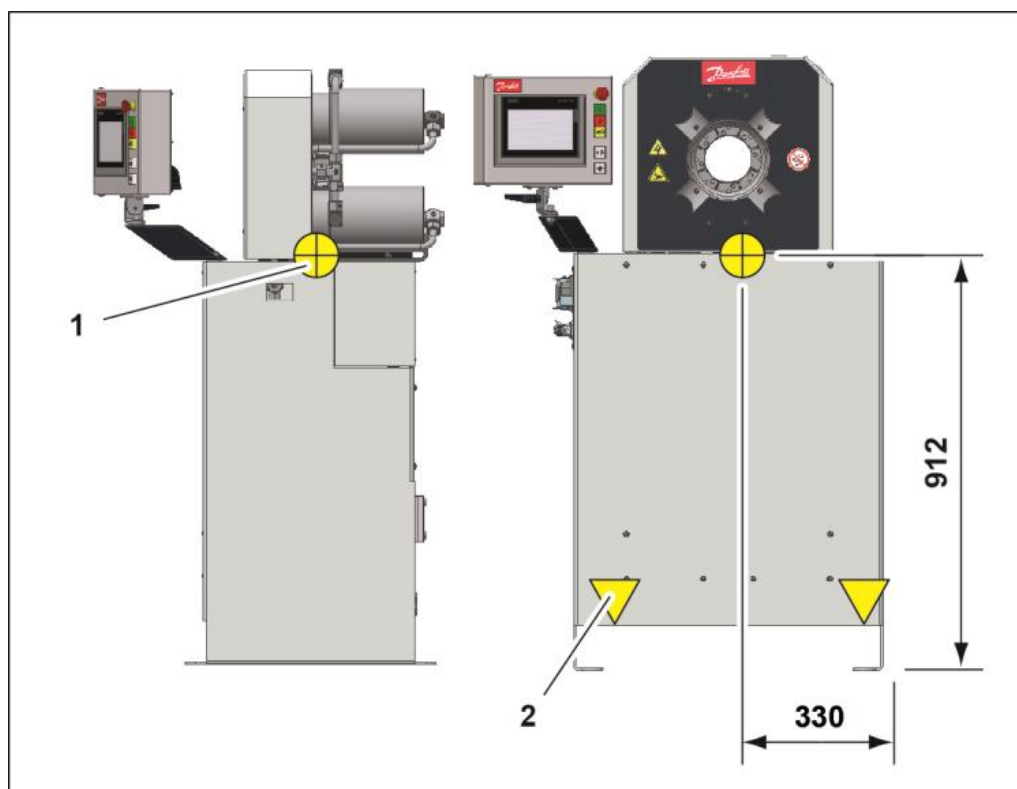

The machine/unit may only be unloaded and transported by means of a forklift, a lift truck or a crane. When a crane is used for transport, lifting gear with a sufficient length and lifting capacity has to be used. For machine/unit weight, please refer to "Technical data" in Section 3.

### WARNING!



#### **Danger from falling loads!**

Risk of injury from falling loads.

- Do not stand under suspended loads.

## 4 Transport and commissioning

### 4.2 Intermediate storage of machine/unit

<b>WARNING!</b>	
	<p><b>Danger from tilting machine/unit!</b></p> <p>The machine/unit may tilt if it is transported improperly. There is a risk of being injured.</p> <ul style="list-style-type: none"><li>• Consider the machine/unit's centre of gravity (1).</li><li>• Only lift the machine/unit at the designated points.</li></ul>

1. Lift the machine/unit with a forklift, lift truck or crane at the designated points (2) and transfer it to the location of installation.

### 4.2 Intermediate storage of machine/unit

If the machine/unit cannot be mounted immediately upon delivery, it must be protected against:

- Contamination,
- Weather influences,
- Mechanical damage.

The machine/unit components may only be stored in closed rooms and under the following conditions:

- temperature between 10°C and 35°C,
- maximum air humidity 80% (non-condensating).

### 4.3 Commissioning

The machine is commissioned by the customer's fitter.

1. Place the machine on an even ground at the place of installation.

<b>WARNING!</b>	
	<p><b>Risk by tilting machine!</b></p> <p>If not bolted to the floor, the machine may tilt. There is a risk of being injured.</p> <ul style="list-style-type: none"><li>• Fix the machine on the floor.</li></ul>

## 4 Transport and commissioning

### 4.3 Commissioning

---

2. Use suitable bolts to fix the machine legs on the floor.



Place the machine in a way so that it is easily accessible for maintenance work from all sides.

3. Check the machine for damage.
4. Check the electric cables for damage.
5. Train the operating staff and record training sessions in "Declaration of trained staff", Section 9.

#### WARNING!



##### **Risk of injuries!**

Machine components might loosen during transport. Such components might be flung out during to the forming process. There is a risk of being injured.

- Open and close the machine several times without any work-piece.
- Check the machine for atypical noise.

#### 4.3.1 Filling hydraulic oil

If the UNIFLEX forming machine was purchased without hydraulic oil filling, the appropriate new, clean and pre-filtered hydraulic oil has to be filled before commissioning (for oil type, please refer to "Technical data" in Section 3).

## 4 Transport and commissioning

### 4.3 Commissioning

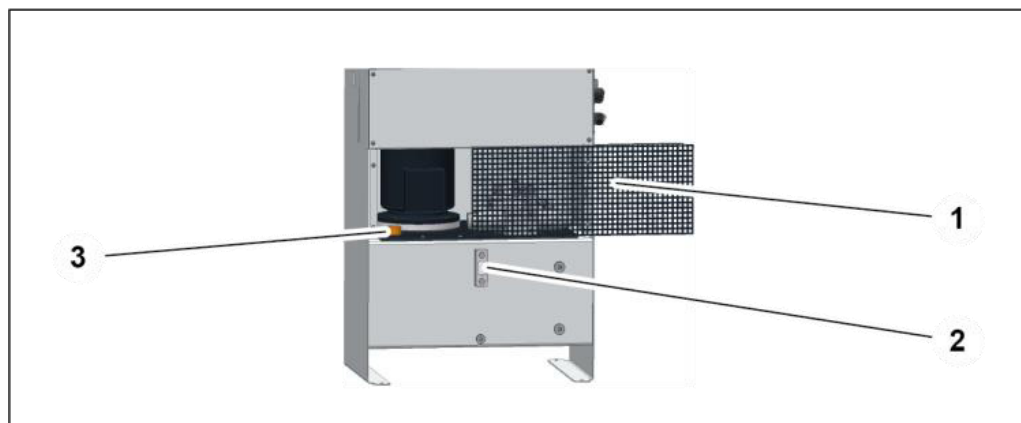

#### CAUTION!



##### Risk of injuries!

Contact with hydraulic oil and other consumables imposes a risk of injuries for the skin, eyes, respiratory and intestinal tracts! Hydraulic liquid spills impose danger of slipping and falling!

- Observe supplier's protection and safety instructions (see data sheet).
- Wear personal protection equipment.
- Do not eat, drink or smoke in the working area and when handling consumables.
- Ensure good ventilation.
- Avoid floor contamination.

#### ATTENTION!



##### Risk of fire!

Hydraulic liquid spray or spills imposes a risk of fire.

- Avoid ignition sources (welding, cutting and soldering work) near the hydraulic oil filling.

1. Dismantle the grating (1).
2. Open the bleed screw (3).
3. Fill in hydraulic oil; for quantity and type, please refer to "Technical data" in Section 3. The oil level can be read on the fill level indicator (2). The oil level should be at the centre of the fill level indicator.
4. Close the bleed screw (3).
5. Mount grating (1).



## 4 Transport and commissioning

### 4.3 Commissioning

---

6. Do not operate the machine for a minimum of four hours so that the dirt particles in the system may settle.

#### 4.3.2 Electrical connection

##### ATTENTION!



##### Risk of damage to machinery

The voltage range described in this Section is only permissible for multi-voltage machines (MVA). Reconnecting the machine with a fixed input voltage will result in the destruction of the machine.

- Do not reconnect machines with fixed input voltage.

##### WARNING!



##### Risk by electrical voltage!

There is a risk of electrocution near the live parts!

- Work on electric systems may only be performed by qualified electricians or instructed and trained persons under the supervision of a qualified electrician.
- Do not operate the machine without a sufficiently rated ground wire.
- Deactivate the machine and secure it against unintentional restart before maintenance.

## 4 Transport and commissioning

### 4.3 Commissioning

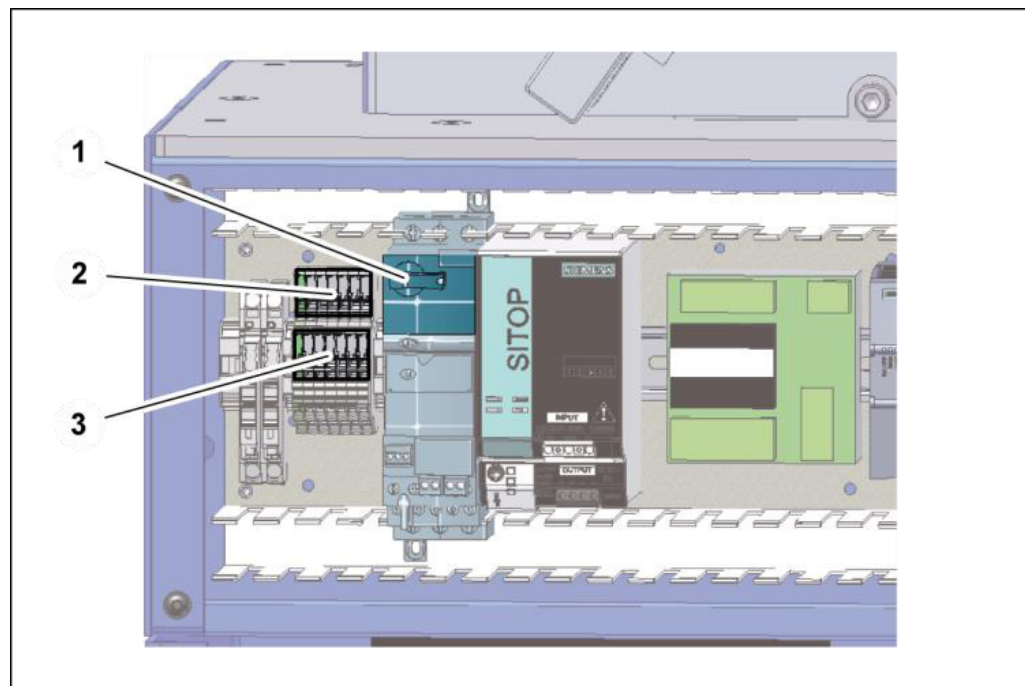

1. Place the voltage selection plug on the correct slot in the control cabinet -  $\Delta$  230 V at the bottom connection (3), Y 400 V at the top connection (2).
2. Set the motor protection switch (1) as specified in the Technical data.



The permissible voltage frequency ranges and the relevant motor protection setting are also indicated on the sticker in the control cabinet.

3. Have the power cable of the machine connected to the local mains by a qualified electrician according to the regulations of the Electricity Board.
4. Check the electric motor rotational direction according to the arrow. Exchange outer cable (phases) of the connection, if required.

## 4 Transport and commissioning

### 4.3 Commissioning

---

#### ATTENTION!



#### **Risk of damage to machinery!**

Extended operation of the motor with an incorrect rotational direction or operating the machine without oil will destroy the hydraulic pump.

- Make sure that the hydraulic oil filling in the machine is sufficient before starting the machine.
- Ensure that the rotational direction of the motor is correct. Observe the red arrow on the motor cover.

## 4 Transport and commissioning

### 4.3 Commissioning

---

#### 4.3.3 Bleeding the hydraulic system

1. Switch on the machine.
2. Operate the machine in the idle mode for two minutes in order to fill the pump with oil.
3. Open and close the tool several times.
4. Check oil level, add hydraulic oil if required.

## 5 Operation

### 5.1 What you have to observe

---

## 5 Operation

### 5.1 What you have to observe

The operator has received the Operation Manual from the owner, has read and understood it and will observe it.

#### Before starting and/or re-starting

- Ensure sufficient illumination of the working area of the machine/unit.

#### During operation

- Observe the safety instructions on the machine/unit.
- Make sure that no other persons stay in the working area.
- Use appropriate aids to handle heavy workpiece.
- Each movement of the hand must be observed.
- The control cabinet must be closed securely.
- Eating, drinking and smoking at the workplace is prohibited.
- Wear close-fitting clothes.
- Do not wear watches or jewellery.

### 5.2 Activation

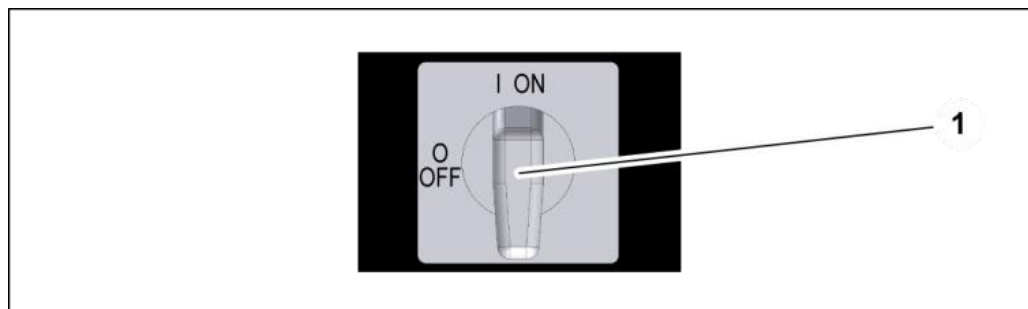

1. Check that there is no emergency-stop situation.
2. Activate the power switch (1). The control starts the operating system; the starting screen showing the UNIFLEX logo will appear after a few seconds.

## 5 Operation

### 5.3 Forming the workpiece

---

## 5.3 Forming the workpiece

### 5.3.1 Prerequisites

Prerequisites for a correct forming process:

- The die system and the workpiece match each other.
- The proper jaw system is correctly mounted in the tool.
- The forming dimension and the dies have been entered in the control system, please also refer to "Setting the forming dimension" in Section 5.
- Preferably form the workpiece in the centre of the crimping die length. Eccentric forming leads to a conical forming result and an increased one-sided wear of the die system and the bearing plates.

### 5.3.2 Remote automatic mode, via dual foot switch

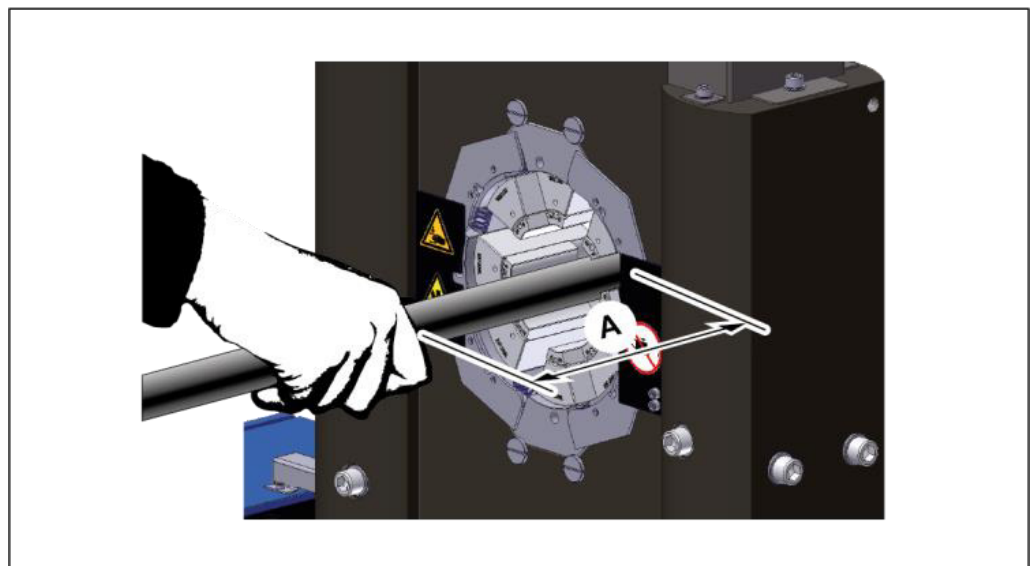

## 5 Operation

### 5.3 Forming the workpiece

#### WARNING!



#### Risk of squeezing!

When the die system closes, there is a risk of getting squeezed between the die and the workpiece.

- Keep the feed opening for the workpiece as small as possible.
- Keep a minimum distance of 120 mm (A) to the die system.

1. Press [



The operation mode Remote automatic via the dual foot switch is only functional if the plug of the dual foot switch is connected to the control cabinet.

## 5 Operation

### 5.3 Forming the workpiece

#### 5.3.3 Operation mode buttons control panel

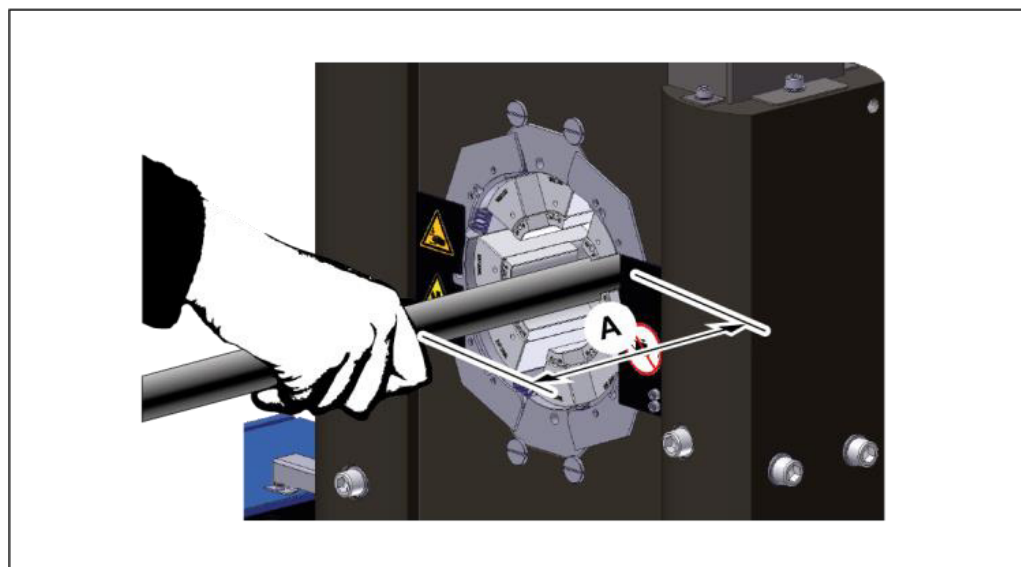

#### WARNING!



#### Risk of squeezing!

When the die system closes, there is a risk of getting squeezed between the die and the workpiece.

- Keep the feed opening for the workpiece as small as possible.
- Keep a minimum distance of 120 mm (A) to the die system.

1. Manually position the pre-mounted workpiece in the tool.
2. Hold the workpiece with one hand during the forming process.
3. Press and hold the button [↵] to close the tool; the forming process starts and ends when the pre-set diameter/pressure is reached.
4. **Manual operation mode:** Press the [↵] button upon completion of the forming process to open the tool.
5. **Semiautomatic operation mode:** Wait until the hold time defined in the control has expired; the tool will then open automatically.
6. Remove the workpiece from the tool.
7. Check the forming dimension after the first forming process. Correct the forming dimension in case of deviations between the actual dimension and the specified dimension (see “Setting the forming dimension” in Section 5).



## 5 Operation

### 5.3 Forming the workpiece



Open the crimping tool only so much that the hose may be placed and/or removed easily. Excessive opening means risk of squeezing and time loss.

#### 5.3.4 Remote automatic mode, via depth stop

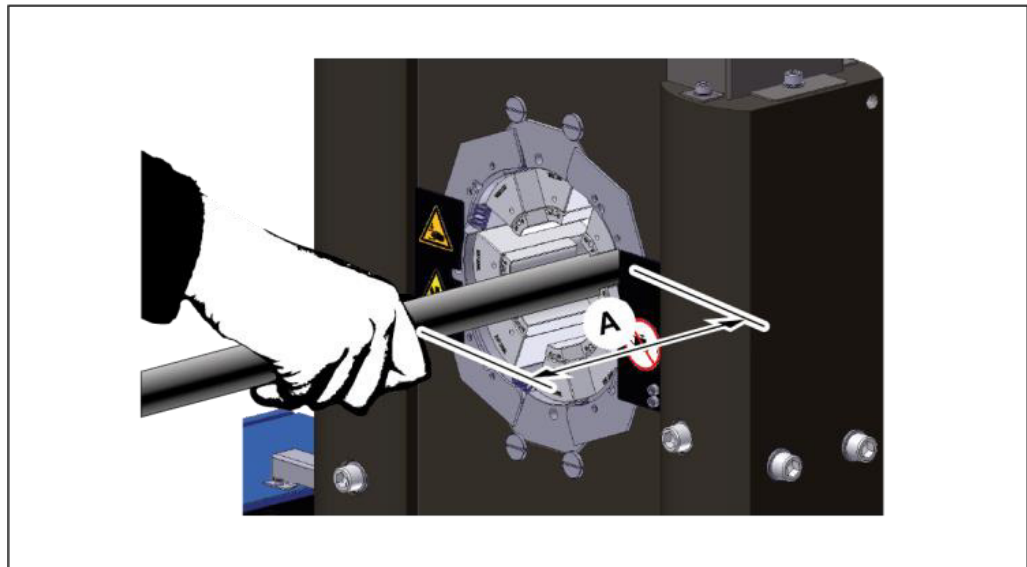

### WARNING!



#### Risk of squeezing!

When the die system closes, there is a risk of getting squeezed between the die and the workpiece.

- Keep the feed opening for the workpiece as small as possible.
- Keep a minimum distance of 120 mm (A) to the die system.

1. Switch on the button to activate the depth stop.
2. Insert the pre-assembled workpiece into the machine manually and press it against the depth stop.
3. Hold the workpiece with one hand during forming; the workpiece must continuously activate the depth stop during forming.
4. **Manual operation mode:** Press the button to open the machine when the forming process is completed.

## 5 Operation

### 5.4 Changing the crimping dies

5. **Semi-automatic operation mode:** Wait until the hold time defined in the control has expired; the tool will then open automatically.
6. Remove the workpiece from the tool.
7. Check the forming dimension after the first forming process. Correct the forming dimension in case of deviations between the actual dimension and the specified dimension (see "Setting the forming dimension" in Section 5).



The Automatic External mode with the depth stop is only functional if the connection of the depth stop is established in the control cabinet.

## 5.4 Changing the crimping dies

### 5.4.1 Changing the crimping dies using a die wrench

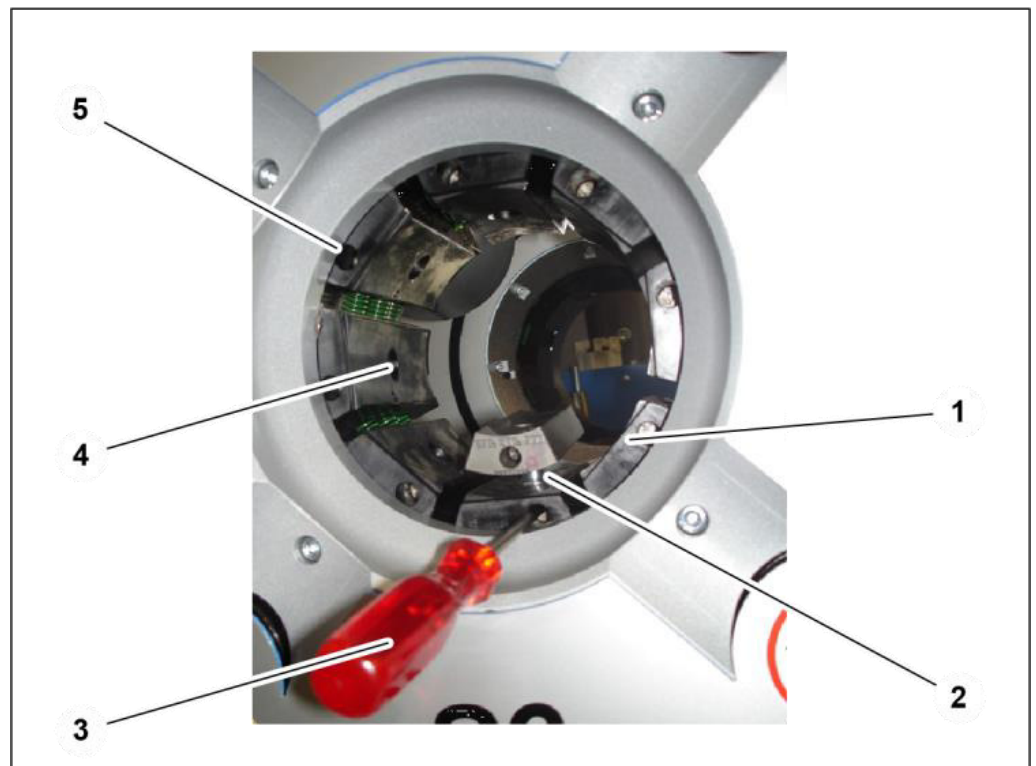

#### Positioning the crimping dies

1. Close the crimping tool until the holes (5) are visible for using the locking bolt.

## 5 Operation

### 5.4 Changing the crimping dies

2. Switch off the machine using the main switch and secure it against switching on unintentionally.

#### WARNING!



##### Risk of squeezing!

When the die system closes, there is a risk of getting squeezed between the dies.

- Only replace the crimping dies when the machine is switched off.

3. Use the supplied die wrench (3) to push and hold the locking bolt backward in the basic die (1).
4. Place the crimping dies into the mounting hole (4) using the retaining bolt (2).
5. Remove the die wrench (3) to release the pressure on the locking bolt - the crimping die is now fixed.



Always use a complete set of equal crimping dies with the same identification and diameter. One set comprises eight crimping dies or seven crimping dies and one matching marking die.

#### Removing the crimping dies

1. Close the crimping tool until the holes (5) are visible for using the retaining bolt.
2. Switch off the machine using the main switch and secure it against switching on unintentionally.

#### WARNING!



##### Risk of squeezing!

When the die system closes, there is a risk of getting squeezed between the dies.

- Only replace the crimping dies when the machine is switched off.

3. Hold the crimping die to be removed with one hand.
4. Use the other hand to push and hold the locking bolt backward in the basic die (1) by means of the die wrench (3).
5. Remove the crimping die concerned.

## 5 Operation

### 5.5 Replacing the intermediate dies

---

6. Remove the die wrench (3) and release the pressure on the locking bolt.



After forming heavy fittings, the locking bolt may be slightly sluggish. In this case, use a mallet to release the locking bolt by slightly hitting on the die wrench.

### 5.5 Replacing the intermediate dies

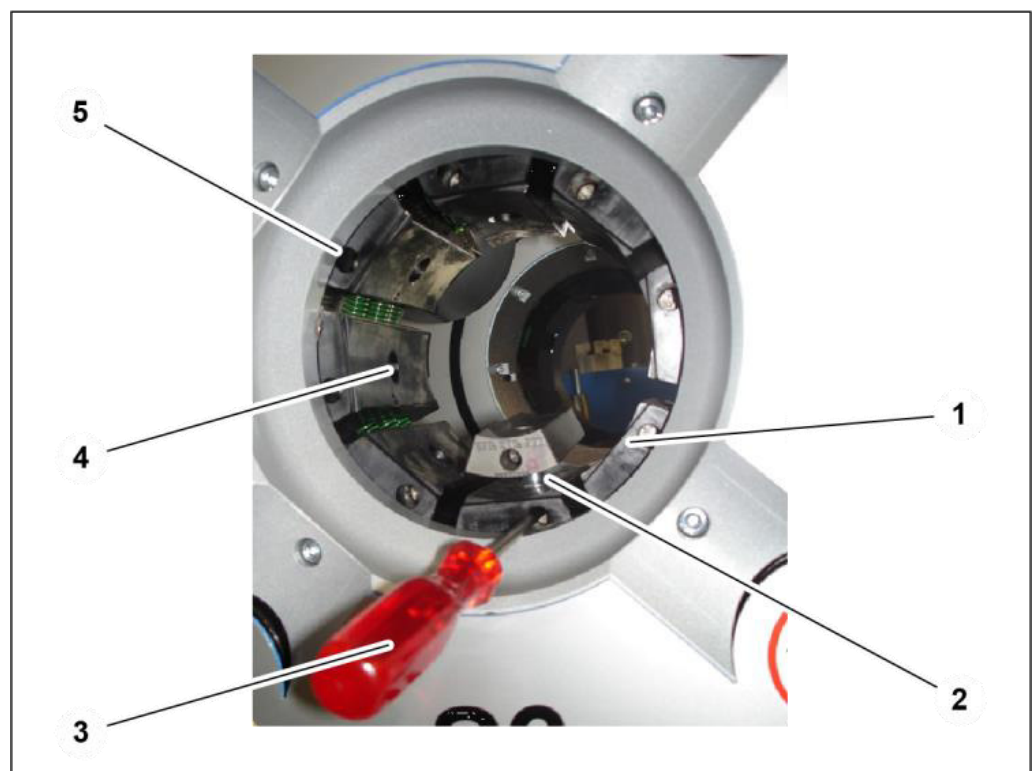

#### Position the intermediate dies

1. Close the crimping tool until the holes (5) are visible for using the locking bolt.
2. Switch off the machine using the main switch and secure it against switching on unintentionally.

## 5 Operation

### 5.5 Replacing the intermediate dies

#### WARNING!



#### Risk of squeezing!

When the die system closes, there is a risk of getting squeezed between the dies.

- Only replace the intermediate dies when the machine is deactivated.

3. Use the supplied die wrench (3) to push and hold the locking bolt backward in the basic die (1).
4. Place the intermediate dies into the mounting hole (4) using the retaining bolt (2).
5. Remove the die wrench (3) to release the pressure on the locking bolt - the intermediate die is now fixed.



Always mount a complete set of identical intermediate dies with the same label and diameter.

#### Removing the intermediate dies

1. Close the crimping tool until the holes (5) are visible for using the locking bolt.
2. Switch off the machine using the main switch and secure it against switching on unintentionally.

#### WARNING!



#### Risk of squeezing!

When the die system closes, there is a risk of getting squeezed between the dies.

- Only replace the intermediate dies when the machine is deactivated.

3. Hold the intermediate die to be removed with one hand.
4. Use the other hand to push and hold the locking bolt backward in the basic die (1) by means of the die wrench (3).
5. Remove the intermediate die concerned.

## 5 Operation

### 5.5 Replacing the intermediate dies

6. Remove the die wrench(3) and release the pressure on the locking bolt.



#### ATTENTION!



##### **Risk of damage to machinery!**

If the profile 266/268/237 intermediate dies (1) are placed in the tool by means of crimping dies PB 239 and QDC 239, the base dies, the locking bolts in the base dies as well as the retaining bolts of the intermediate and crimping dies will be destroyed.

- Only mount profile 266/268/237 intermediate dies individually and manually.



After forming heavy fittings, the locking bolt may be slightly sluggish. In this case, use a mallet to release the locking bolt by slightly hitting on the die wrench.

## 5 Operation

### 5.5 Replacing the intermediate dies

#### 5.5.1 Changing the crimping dies with the quick die change system (only profile 239)

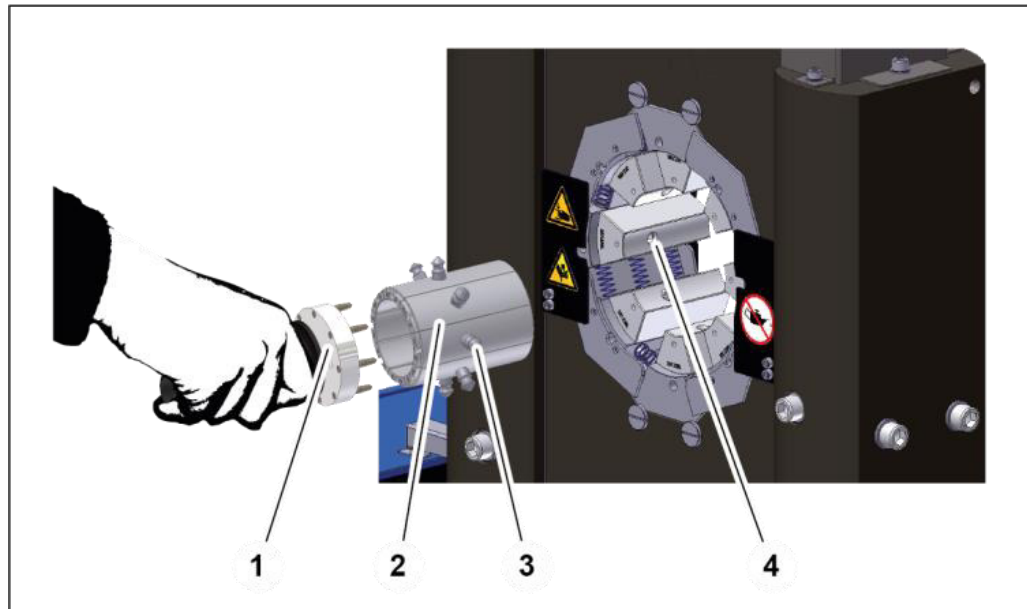

1. Select the change position for crimping dies in the control by activating the button [QDC].
2. Press the [↶ ↷] button to open the crimping tool so that the dies type PB239 can just be inserted.
3. Push the eight pins of the quick die change system (1) into the front holes of the crimping dies (2).
4. Rotate anti-clockwise and remove the crimping dies (2) from the deposit.
5. Check the retaining bolts (3) of the crimping dies for damage.
6. Hold the quick die change system with crimping dies in the centre of the crimping tool.

#### WARNING!



#### Risk of squeezing!

When the die system closes, there is a risk of getting squeezed between the dies.

- Take care that no parts of your body are inside the forming area when the crimping dies close.

## 5 Operation

### 5.5 Replacing the intermediate dies

#### ATTENTION!



#### Risk of damage to machinery!

The retaining bolts and the crimping dies will be destroyed if the retaining bolts do not fit in the mounting hole of the base dies or intermediate dies.

- Pay attention to the correct position of the quick die change system with crimping dies.

7. Press the [→|←] button to close the tool.  
All retaining bolts (3) must slide into the relevant mounting hole (4) of the basic or intermediate dies, and the spring-mounted pressure pieces must engage into the retaining bolts.
8. Remove the quick die change system (1) and check that the crimping dies fit tightly.
9. Proceed in reverse order to remove the crimping dies.



Always use a complete set of equal crimping dies with the same identification and diameter. One set comprises eight crimping dies or seven crimping dies and one matching marking die.

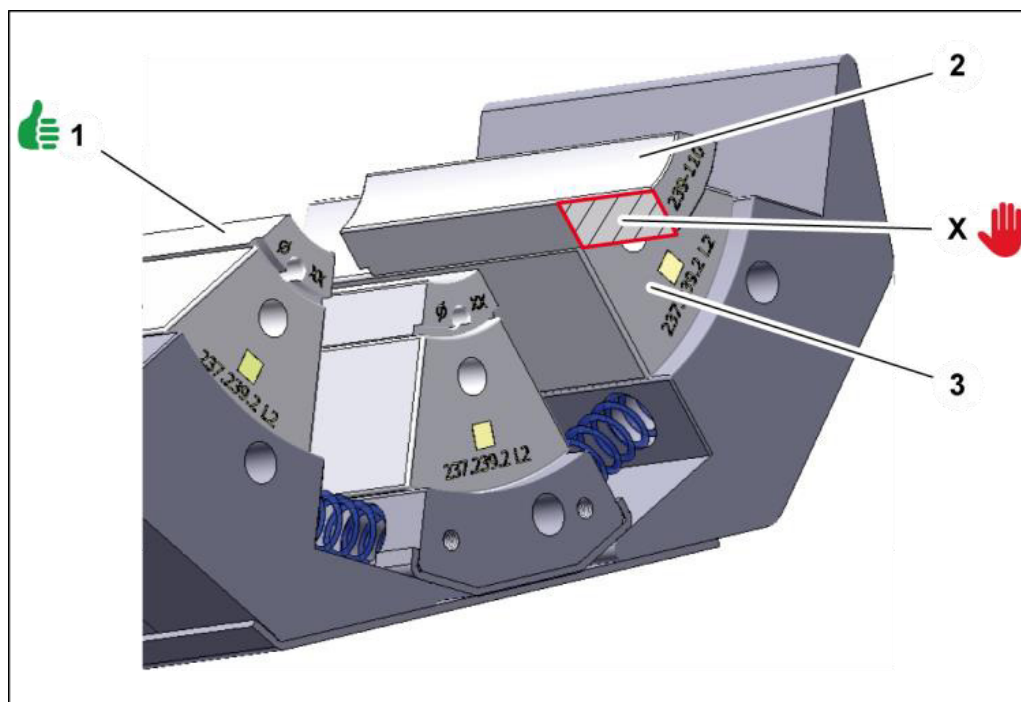



## 5 Operation

### 5.6 Depth stop (accessory)

#### ATTENTION!



#### Risk of damage to machinery!

If the crimping dies protrude beyond the basic and intermediate dies, the crimping dies, the intermediate dies and the machine will be damaged (see (X) in the figure). In the figure, the crimping die (2) is placed incorrectly.

- Place the crimping die (2) in the base and/or intermediate die (3) so that it does not protrude. In the figure, the crimping die (1) is placed correctly.

### 5.6 Depth stop (accessory)

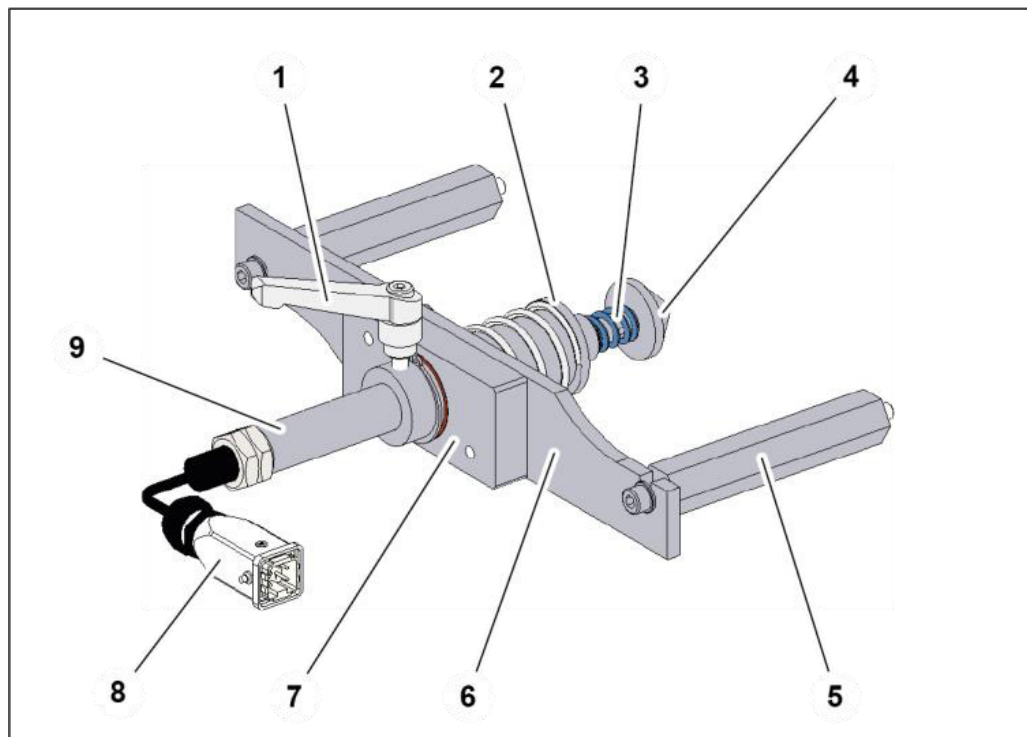

- (1) Clamp lever
- (2) Sleeve
- (3) Plunger
- (4) Stop pin
- (5) Spacer
- (6) Clamping yoke
- (7) Guidance

## 5 Operation

### 5.7 Setting the forming dimension

---

- (8) Connection cable with plunger switch
- (9) Sleeve

### 5.7 Setting the forming dimension

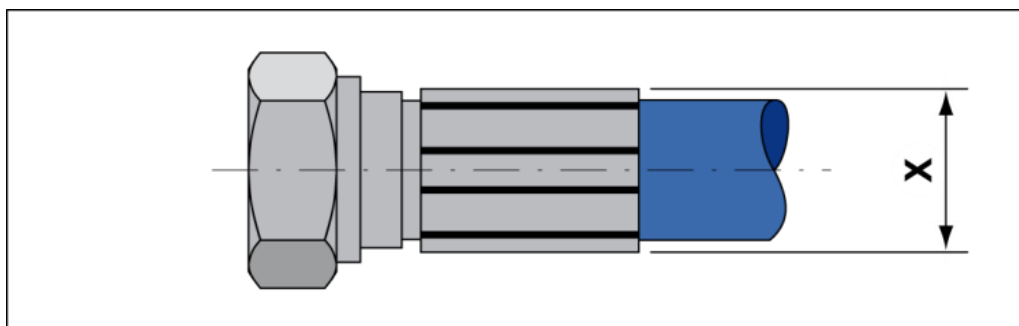

The forming dimension (X) must be set specifically for the workpiece.

1. Read the forming dimension in the forming dimension table of the system supplier, e.g.  $\varnothing$  17.4 mm.
2. Select crimping dies with a smaller or the same diameter, e.g.  $\varnothing$  17 mm,
3. Place the crimping dies in the tool.
4. Set the control and/or micrometer to the requested dimension:  
**Control system:** Forming dimension diameter  
**Micrometer:** Workpiece forming dimension less crimping die diameter
5. Form the workpiece.
6. Check the workpiece.
7. If the dimension is reached: manufacture other identical workpieces.
8. If the dimension is not reached: Adjust difference on control and/or in the micrometer, repeat the forming process and check the workpiece.

### 5.8 Forming travel limitation

If the forming process is started outside the maximum forming range, see “Technical data” in Section 3, the forming distance limitation is activated and the machine stops, depending on the equipment. With machines without any forming distance limitation,

## 5 Operation

### 5.9 Stop

---

tools components may be damaged if the forming range is exceeded.

### 5.9 Stop

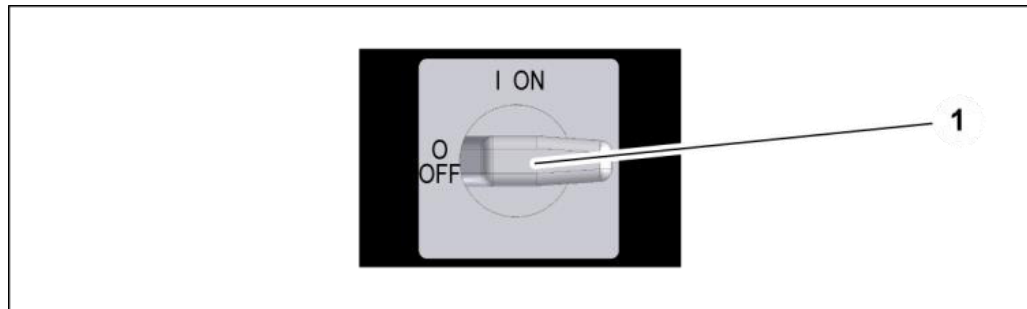

1. Complete the forming process.
2. Deposit the work piece outside the machine.
3. Deactivate the main switch (1).
4. Check the machine for contamination, leaks and external damage.
5. Check the crimping tool and retaining bolts for contamination, damage and secure fitting.
6. Check the oil level.
7. Remove contamination, dust and chips using a vacuum.



Inform the fitter in case of damage or other irregularities.

## 5.10 Emergency stop

### In case of an emergency

Immediately press the emergency-stop button (1) in cases of emergency. The crimping tool movement will be stopped. The drive unit is shut down.

### Restart after and emergency

#### WARNING!



#### Risk of injuries!

The emergency-stop button was probably activated due to the occurrence of a hazardous situation. A restart of the machine may cause injuries if the hazardous situation has not yet been remedied!

- Remedy the hazardous situation before a restart.

1. Remedy the cause of the emergency stop.
2. Unlock the emergency-stop button.
3. Reset the error messages on the control.

## 5.11 Cleaning

#### ATTENTION!



#### Risk of damage to machinery!

If the machine is cleaned with a steam jet or compressed air, dirt and water may ingress in the machine and cause serious damage.

- Do not use a steam jet to clean the machine.
- Do not use compressed air to clean the machine.

1. Vacuum the machine from metal abrasion (crimping scale) in the opened crimping tool, or use a soft cloth to clean it. For

## 5 Operation

### 5.11 Cleaning

---

this purpose, remove the crimping dies and the intermediate dies.

## 6 Maintenance

### 6.1 What you have to observe

---

## 6 Maintenance

Regular maintenance will ensure the continuous operation reliability of the device.

### 6.1 What you have to observe

This Section describes action to be taken by you as the fitter regularly to ensure the troublefree use of the machine/unit.

- Maintenance work may only be performed by qualified maintenance staff (machine/unit fitters).
- Repair work on the machine/unit or components may only be performed by appropriately qualified expert staff or UNIFLEX experts!
- The machine/unit must always be deactivated during maintenance work (see "Deactivation" in Section 5). Use the lock to prevent the main switch from being switched on and also attach a sign. Example text:

Machine/unit out of service for  
maintenance work!  
Do not switch on!

- Welding, flame-cutting and grinding work on and in the machine/unit and its environment must be approved in advance. There is a risk of fire. The machine/unit must be cleaned from dust and inflammable substances. Adequate ventilation must be ensured.

### 6.2 Maintenance schedule

If not specified otherwise, inspections listed in the maintenance schedule are visual inspection. Replace defective parts.

If you work in 2 shifts, the check frequency has to be doubled. If you work in 3 shifts, you proceed as with 2-shift operation.

Record maintenance work performed in the maintenance log.

## 6 Maintenance

### 6.2 Maintenance schedule

Maintenance item	Weekly	Monthly	Every 6 months	Number of years
<b>Hydraulic system</b>				
Hydraulic energy lines – hoses: Check for porosity and leaks.		X		
Hydraulic energy lines - bolted connections of hoses and pipes: Check for leaks.		X		
Hydraulic oil: Check oil level, add oil if required (see "Replacing hydraulic oil" in Section 6).		X		
Hydraulic oil: Replace				1
Hydraulic hoses: Have replaced (DIN 20066) no later than six years after manufacture (see label). Make sure that replacement hoses are of equivalent quality (high-pressure hoses).				6
<b>Crimping tool</b>				
Crimping tool: Check for damage and wear.		X		
Retaining bolt: Check for damage.		X		
Slide bearing plates: Check for wear (see "Checking and replacing slide bearing plates" in Section 6).			X	
Pressure springs between base dies: Check for damage.			X	
Check all bolted connections for secure fitting and retighten if necessary.				1
<b>Safety equipment</b>				
Emergency-stop button/Emergency stop device: Check function	X			
Fixed guards and covers: Check for completeness and correct installation.		X		
For machines with foot switch, only Check case foot switch for completeness. The case protects the pedals against unintentional activation.		X		
Warning signs on the machine: Check legibility (see "Warning signs on the machine" in Section 2).			X	

## 6 Maintenance

### 6.3 Hydraulic oil change

---



Hydraulic oil changes and wear part replacements must be recorded in the maintenance log!

### 6.3 Hydraulic oil change

#### CAUTION!



##### Risk of injuries!

Contact with hydraulic oil and other consumables imposes a risk of injuries for the skin, eyes, respiratory and intestinal tracts! Hydraulic liquid spills impose danger of slipping and falling!

- Observe supplier's protection and safety instructions (see data sheet).
- Wear personal protection equipment.
- Do not eat, drink or smoke in the working area and when handling consumables.
- Ensure good ventilation.
- Avoid floor contamination.

#### ATTENTION!



##### Risk of fire!

Hydraulic liquid spray or spills imposes a risk of fire.

- Avoid ignition sources (welding, cutting and soldering work) near the hydraulic oil filling.



## 6 Maintenance

### 6.3 Hydraulic oil change

---

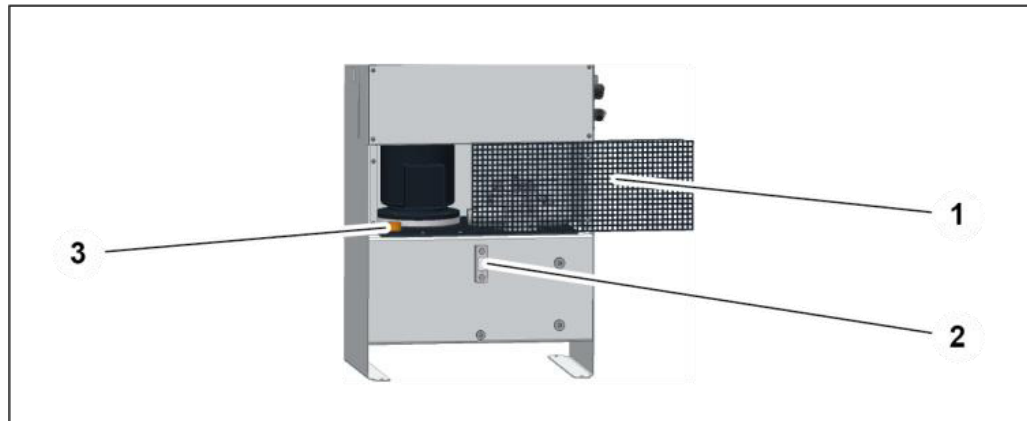

1. Deactivate the machine on the main switch and secure it against unintentional restart.
2. Let the hydraulic oil cool down until the tank enclosure is warm to the touch.
3. Dismantle the grating (1).
4. Open the air ventilation cap (2).
5. Pump out hydraulic oil using an external pump.
6. Add new hydraulic oil (see “Technical Data” in Section 3).
7. Close the air ventilation cap (2).
8. Mount grating (1).
9. Do not operate the machine for a minimum of four hours so that the dirt particles in the system can settle.
10. Switch on the machine.
11. Operate the machine in the idle mode for two minutes.
12. Run the tool several times to bleed the hydraulic oil system.
13. Check oil level. The oil level should be at the centre of the fill level indicator (2); refill hydraulic oil, if required.



Dispose of the oil in compliance with the applicable local environmental protection regulations.

## 6 Maintenance

### 6.4 Checking and replacing slide bearing plates

---

#### 6.4 Checking and replacing slide bearing plates

##### Checking slide bearing plates

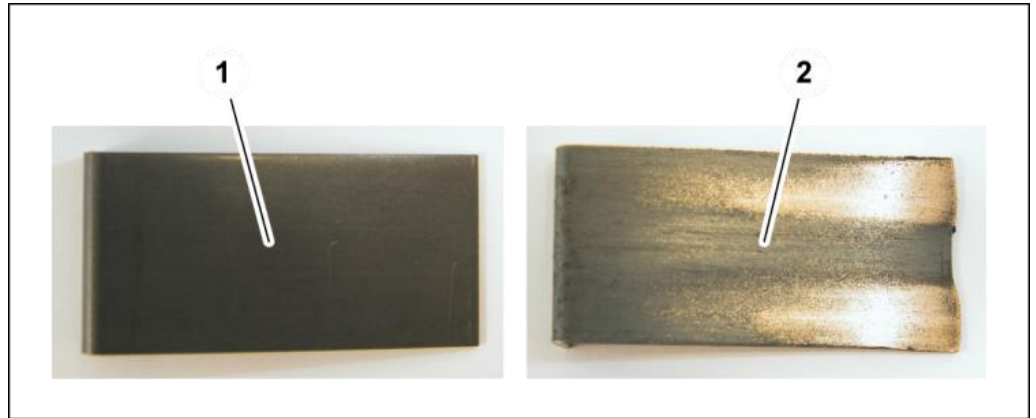

Check slide bearing plates for wear, replace defective parts. The slide bearing plate (1) is new, the slide bearing plate (2) is worn.

#### **ATTENTION!**



##### **Risk of damage to machinery!**

Worn slide bearing plates may cause damage to the machine and lead to inaccuracies of the forming dimension.

- Replace worn slide bearing plates in good time.

## 6 Maintenance

### 6.4 Checking and replacing slide bearing plates

#### Replacing slide bearing plates

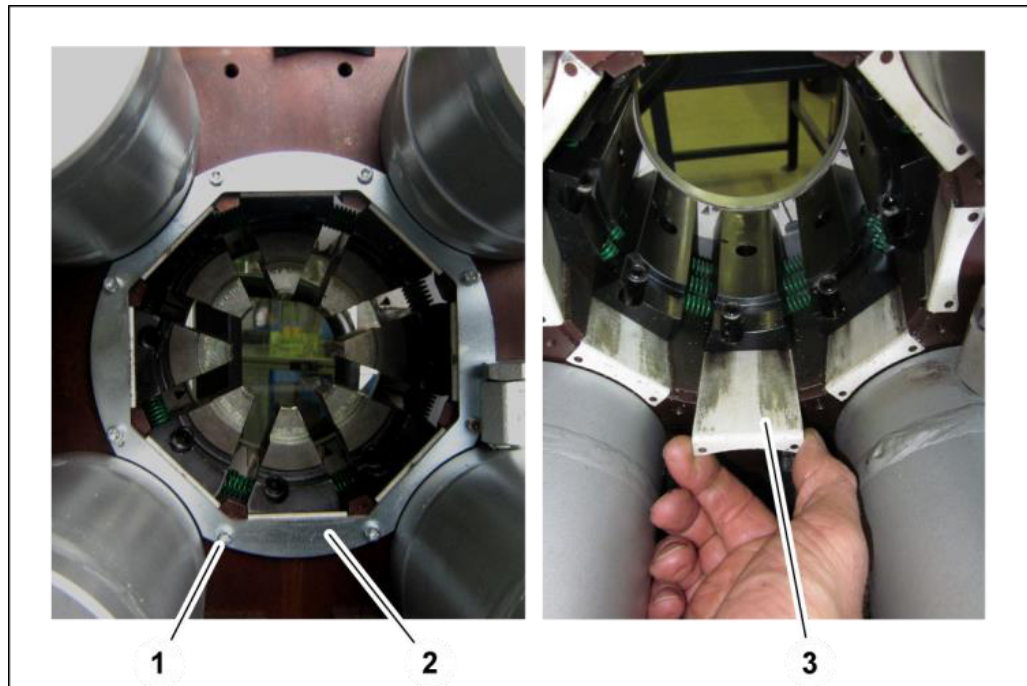

1. Open the crimping tool fully.
2. Deactivate the machine on the main switch and secure it against unintentional restart.
3. Loosen bolts (1) on clamping ring (2).
4. Remove clamping ring (2).
5. Pull out old slide bearing plate (3).
6. Insert the new slide bearing plate (3).  
Replace all eight slide bearing plates in this manner.
7. Remount clamping ring (2).
8. Tighten screws (1).



Shims, if present, have to be inserted at the same position as before.



After replacement of the slide bearing plates, the machine has to be recalibrated (see CONTROL C2 / IPC Operation Manual).

## 7 Troubleshooting

### 6.4 Checking and replacing slide bearing plates

## 7 Troubleshooting

Error	Cause	Remedy
Machine does not close/open	Main switch is OFF	Activate the main switch
	Voltage incorrect	Check voltage supply
	Power plug defective	Check power plug and replace if necessary
	Rotational direction of electric motor incorrect	Check rotation direction, correct electrical connection
	Insufficient amount of hydraulic oil	Refill oil
	Power unit defective	Check power unit
Machine forms unevenly/conically	Operation buttons defective	Check operation buttons and replace, if required
	Bearing plates worn	Check bearing plates for wear and replace if necessary
	Base dies damaged	Check base dies for damage and replace if necessary
	Crimping dies damaged	Check crimping dies for damage and replace if necessary
	Crimping area not centred	Preferably form the workpiece in the centre of the crimping die length.
Crimping dimension not achieved	Bearing plates worn	Check bearing plates for wear and replace if necessary
	Oil pressure too low	Check oil pressure at the MP measuring point, pump or pipe may be leaking or defective, repair or replace
	Incorrect crimping dies used	Check crimping die diameter and profile and exchange, if required (see "Technical data", Section 3, for crimping die profile)

Error messages displayed on the control panel are described in the separate operating instructions of the control system.

## 8 Decommissioning, disposal

### WARNING!



#### Risk by electrical voltage!

There is a risk of electrocution near the live parts!

- Shut down the machine/unit.
- Disconnect the machine/unit from the power supply.

### CAUTION!



#### Risk of injuries!

Contact with hydraulic oil and other consumables imposes a risk of injuries for the skin, eyes, respiratory and intestinal tracts! Hydraulic liquid spills impose danger of slipping and falling!

- Observe supplier's protection and safety instructions (see data sheet).
- Wear personal protection equipment.
- Do not eat, drink or smoke in the working area and when handling consumables.
- Ensure good ventilation.
- Avoid floor contamination.

### ATTENTION!



#### Risk of fire!

Hydraulic liquid spray or spills imposes a risk of fire.

- Avoid ignition sources (welding, cutting and soldering work) near the hydraulic oil filling.

### CAUTION!



#### Risk of injuries!

Parts of the machine/unit may be under pressure and/or tension. Loosening components may impose a risk of injuries!

- De-pressurize the machine/unit before performing any work and check for potential sources of hazard.

## 8 Decommissioning, disposal

### 8.1 Dismantling

---

#### 8.1 Dismantling

This section describes activities to be performed by you as the operator to ensure the safe dismantling of the machine/unit.

- The machine/unit may only be dismantled by entrusted and qualified staff.
- Open the machine/unit completely.
- Depressurise the machine/unit before dismantling it (deactivate the hydraulic pump and secure it against restart; operate valve manually, if any; open bolted hydraulic connections slowly and carefully).
- Check the machine/unit for mechanical tension and consider it during dismantling.
- Empty the machine/unit of all consumables, see “Maintenance”, Section 6.

#### 8.2 Recycling

The machine/unit contains metal, hydraulic hoses, electric cables and electronic components, depending on the type.

As regards disposal, the applicable national environmental protection and waste disposal regulations have to be complied with.

#### 8.3 Consumables and waste

Observe applicable national environmental protection and waste disposal regulations.

Return consumables, e.g. oils, greases, test media, to supplier - they are hazardous waste. Also observe the information given on the safety data sheet.

## 9 Annex



Individual machine/unit components may deviate in their features. Please indicate the serial number of the machine for spare part orders.

## 9 Annex

### 9.1 Accessories (retrofittable)

---

#### 9.1 Accessories (retrofittable)

Accessories	Part code
Quick die change system	QDC 239.5
Die deposit	QDS 239 B QDS 239 C QDS 239 R
TU-QDS crimping die deposit system	TU-QDS F Basic TU-QDS F Shelf TU-QDS F 239 I
End stop	TA S6.2 manual TA S6.3 C A automatic C.2
Mirror	SHS S6.2 Table machine SHS S6.2 B free-standing machines only
Camera set	OCS 10.3 retro
Lamp with magnetic base	LUS
Die wrench	239.017.4
Universal table (only EcoLine and MobileLine)	TU
Crimping dies system	PB 239 / 266

Please contact our Sales department for ordering accessories.

For more control accessories, please refer to the Control C.2 / IPC Operation Manual.



## 9.2 Spare parts list

### 9.2.1 Tool

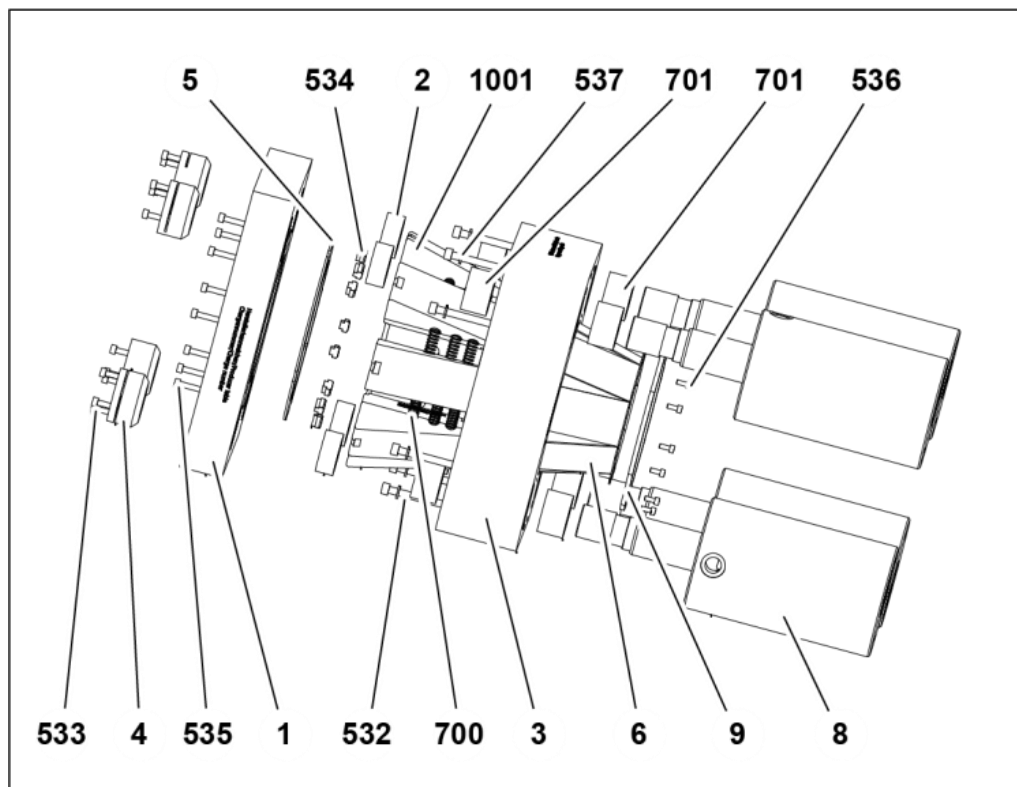

Item	Quantity	Part code	Designation
1	1	266.185.0	Pressure plate, front
2	4	266.187.4	Sleeve
3	1	266.191.0	Pressure plate, back
4	4	266.186.3	Ball nut
5	2	266.195.3	Bearing segment
6	1 set	266.5	Bearing plates
8	4	266.398.3	Hydraulic cylinder
9	2	266.215.3	Clamping segment
532	8	798.110128	Cylinder bolt DIN EN ISO 4762 – M8x100
533	12	798.120066	Cylinder bolt DIN EN ISO 4762 – M6x20
534	8	268.135.4	T-nut DIN 508 M6x8
535	8	798.110112	Cylinder bolt DIN EN ISO 4762 M6x25
536	8	798.110098	Cylinder bolt DIN EN ISO 4762 M5x12
537	8	798.750004	Snap ring DIN 127 Ø8

## 9 Annex

### 9.2 Spare parts list

Item	Quantity	Part code	Designation
700	24	268.150	Pressure spring
701	8	266.193	Sleeve, Ø 45/Ø 50/ length long
1001	8	266.1192	Base dies mounted
-	-	266.1195	Complete tool

#### 9.2.2 Basic dies

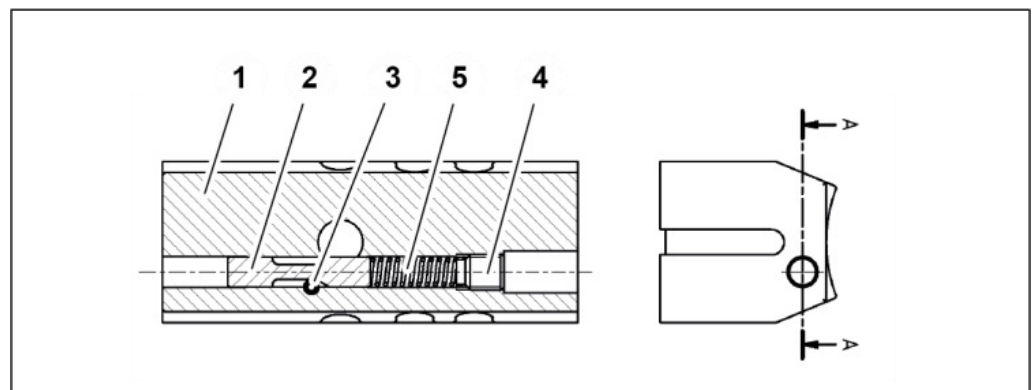

Item	Quantity	Article code	Designation
1	8	266.198.1	Basic dies
2	8	235.008.4	Locking pin
3	8	798.420027	Threaded pin DIN EN ISO 4028 M5x10
4	8	798.420029	Threaded pin DIN EN ISO 4028 M12x16
5	8	D-195A-21	Compression spring

## 9 Annex

### 9.2 Spare parts list

#### 9.2.3 Mechanical equipment

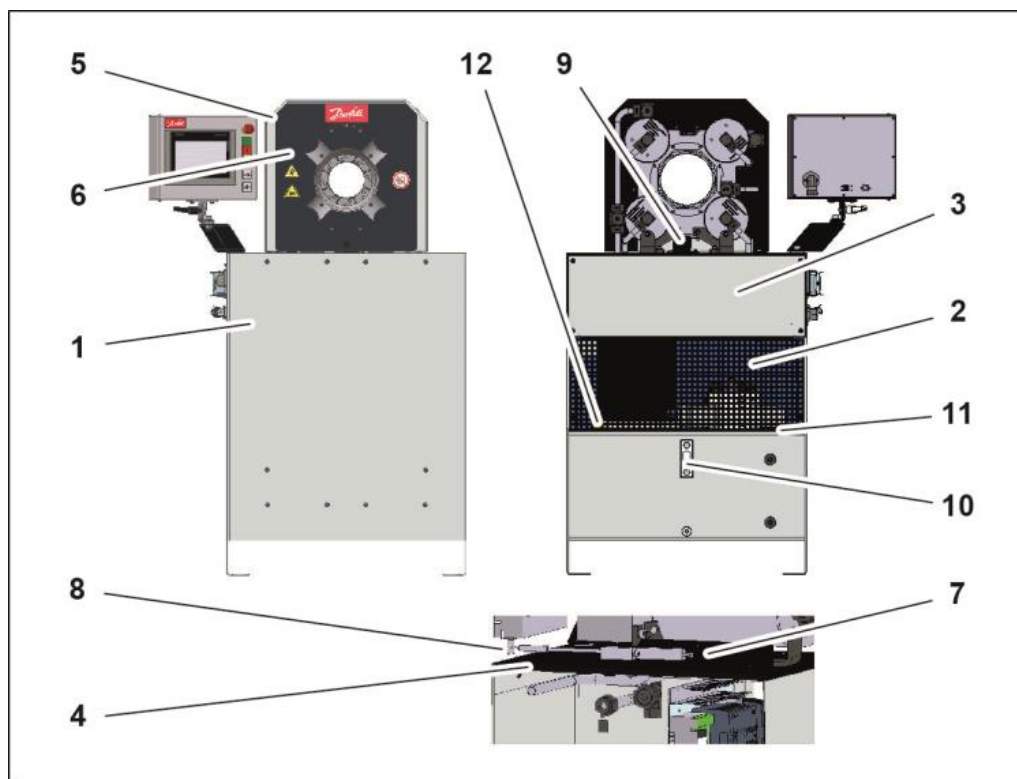

Item	Quantity	Part code	Designation
1	1	268.280.1 + colour code	Chassis
2	1	268.284.3 + colour code	Grid
3	1	268.285.2 + colour code	Cover plate
4	1	266.283.2	Mounting plate
5	1	266.224.2 + colour code	Cover
6	1	777.924.2	Designation sign
7	1	266.256.3	Position encoder mounting angle
8	1	264.243.4	Position encoder stop bracket
9	1	266.255.3	Position encoder cover
10	1	266.353	Level indicator
11	1	268.349.2	Tank seal
12	1	GN 552-R3/4"	air ventilation cap with oil dipstick
No picture	1	715.4	Squeezing risk warning sign
No picture	1	578.4	Oil prohibition sign

## 9 Annex

### 9.2 Spare parts list

Item	Quantity	Part code	Designation
No picture	1	716.4	Warning of hand injuries sign

#### 9.2.4 Hydraulic system

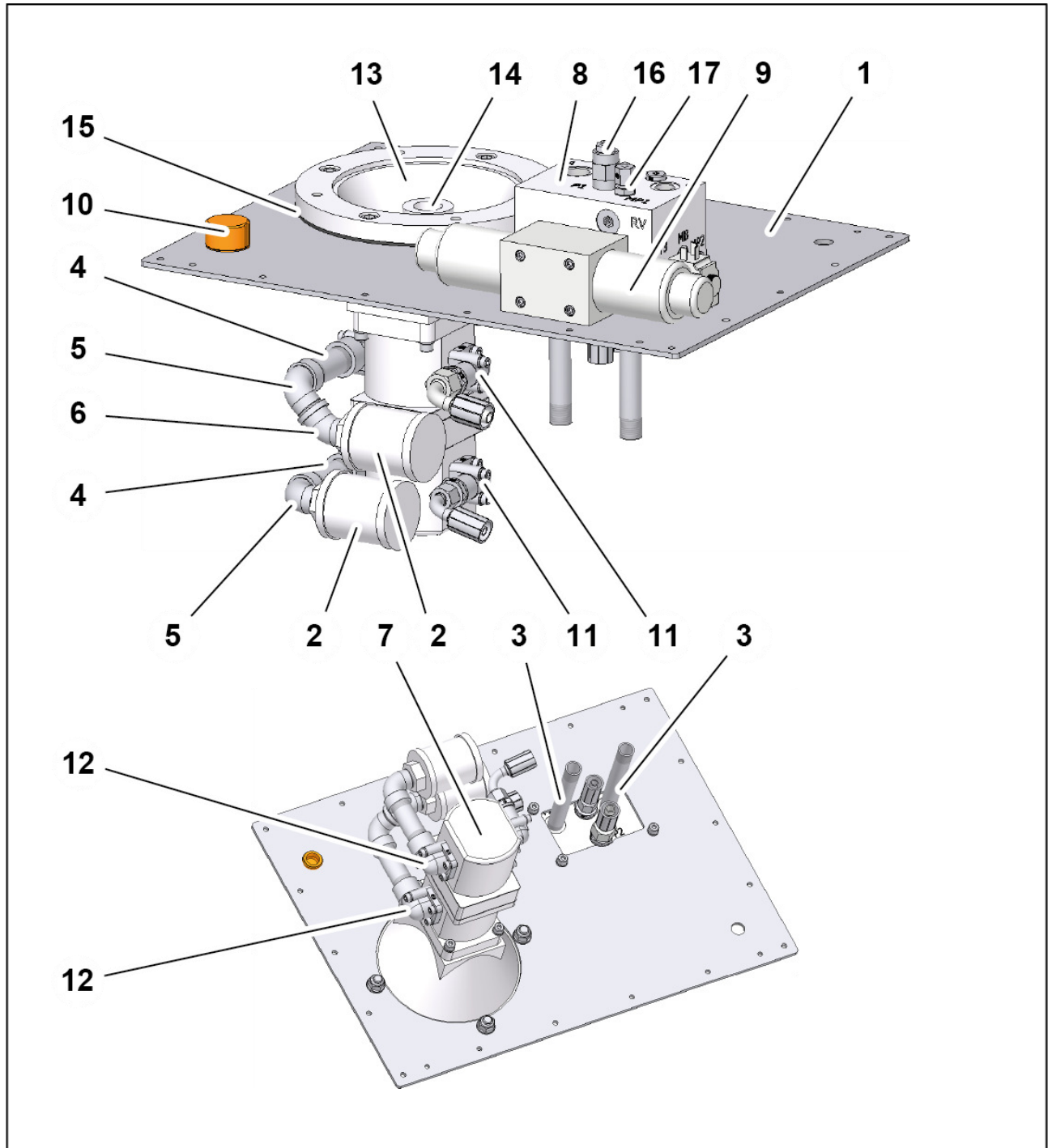

## 9 Annex

### 9.2 Spare parts list

Item	Quantity	Part code	Designation
1	1	268.293.2	Tank cover
2	2	239.517	Suction filter 3/4"
3	2	239.518	Double pipe nipple
4	2	239.520	Double pipe nipple
5	2	239.529	Angle
6	1	239.535	Angle
7	1	268.337	Hydraulic double pump
8	1	268.325.3	Hydraulic block, complete
9	1	777.349	NG 10 valve
10	1	GN 552-R3/4"-A1	air ventilation caps
11	2	777.361	Gear pump flange
12	2	777.362	Gear pump flange
13	1	777.300	Bell housing
14	1	24/30N2a-28	Coupling
15	1	777.301.3	Gasket
16	1	235.326 777.3336 777.341	Pressure limiting valve for hydraulic block 268.325.3_A / 268.325.3_D Pressure limiting valve for hydraulic block 268.325.3_B Pressure limiting valve for hydraulic block 268.325.3_C
17	1	777.325 777.338 777.340	Directional valve for hydraulic block 268.325.3_A / 268.325.3_D Directional valve for hydraulic block 268.325.3_B Directional valve for hydraulic block 268.325.3_C
No picture	1	268.349.2	Tank seal
No picture	1	232.011	Electric motor 4 kW (S6/S8)
No picture	1	266.011	Electric motor 5.5 kW (S10)
No picture	1	238.139	Electric motor 5.5 kW 200 V 60 Hz 3 phases
No picture	1	266.019	Electric motor 5.5 kW 575 V 60 Hz 3 phases

## 9 Annex

### 9.2 Spare parts list

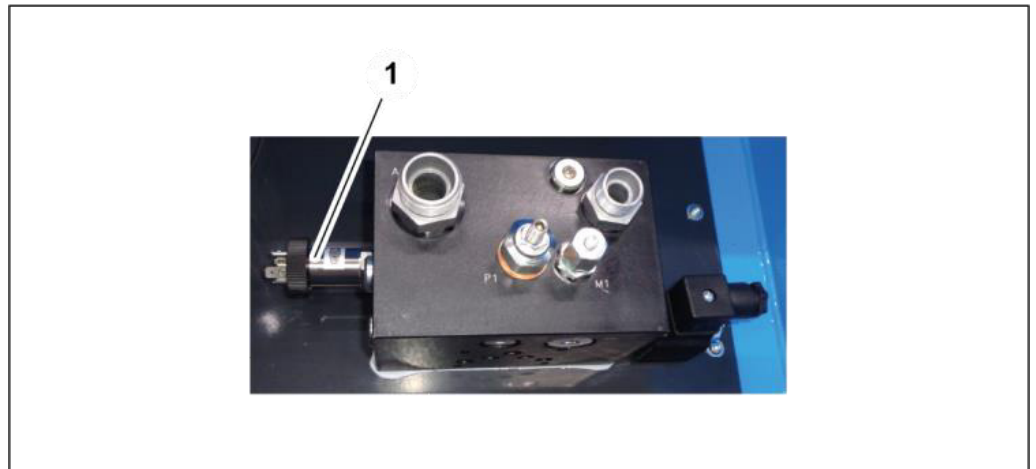

Item	Quantity	Part code	Designation
1	1	220.916	Pressure sensor 0 - 400 bar

#### 9.2.5 Electric equipment

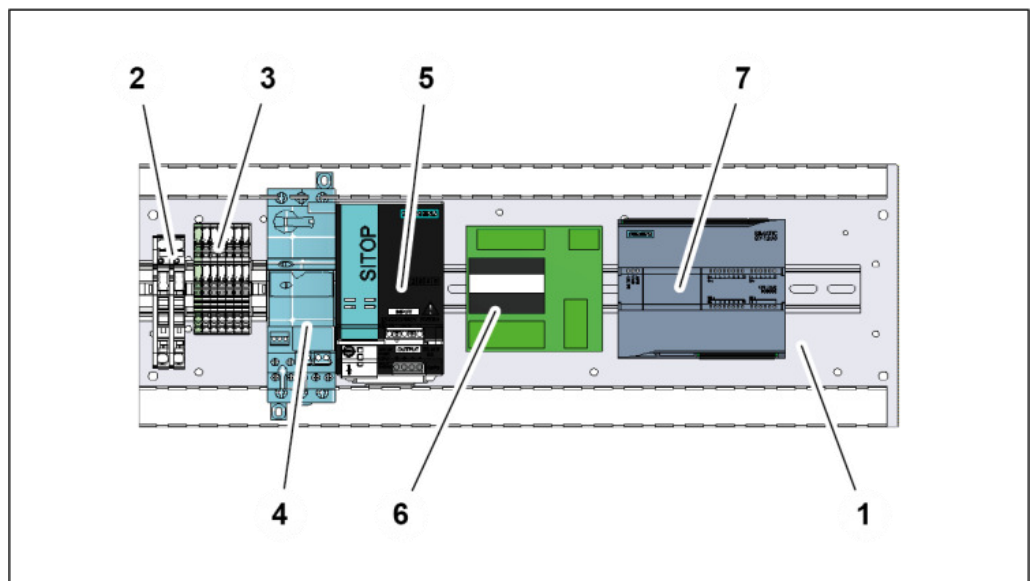

Item	Quantity	Part code	Designation
1	1	807.601	E-plate, complete
2	1	888.652	Clamping block
3	1	888.653	Voltage selection plug
4	1	888.014	Motor protection switch
5	1	807.318	Switching power supply

## 9 Annex

### 9.2 Spare parts list

Item	Quantity	Part code	Designation
6	1	888.406 888.411 888.410	Interface module Relay Optical coupler
7	1	807.375	CPU Controller
No picture	1	VME 0231	Fine wire fuse

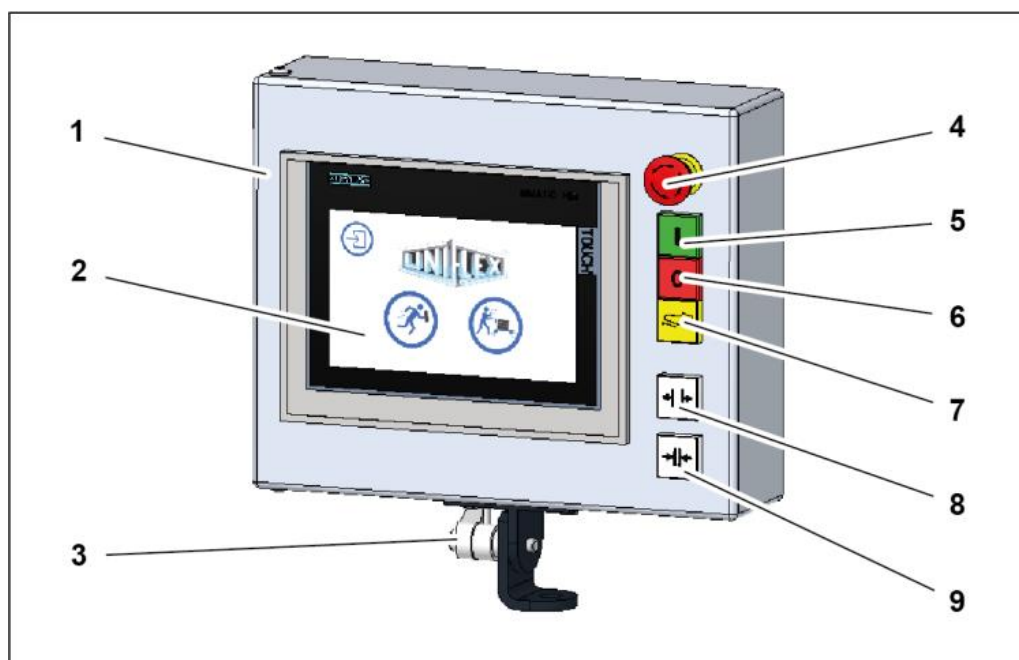

Item	Quantity	Part code	Designation
1	1	807.710	Control panel 800 mm C.2 with memory card
2	1	807.374	Uniflex Touch Panel
3	1	777.022	Clamp lever
4	1	807.067	Emergency-stop button, complete
5	1	800.061	"Motor Start" button
6	1	800.060	"Motor Stop" button
7	1	807.068	Button: Foot pedal switching
8	1	800.063	"Open" button
9	1	800.062	"Close" button

## 9 Annex

### 9.3 Spare parts kit

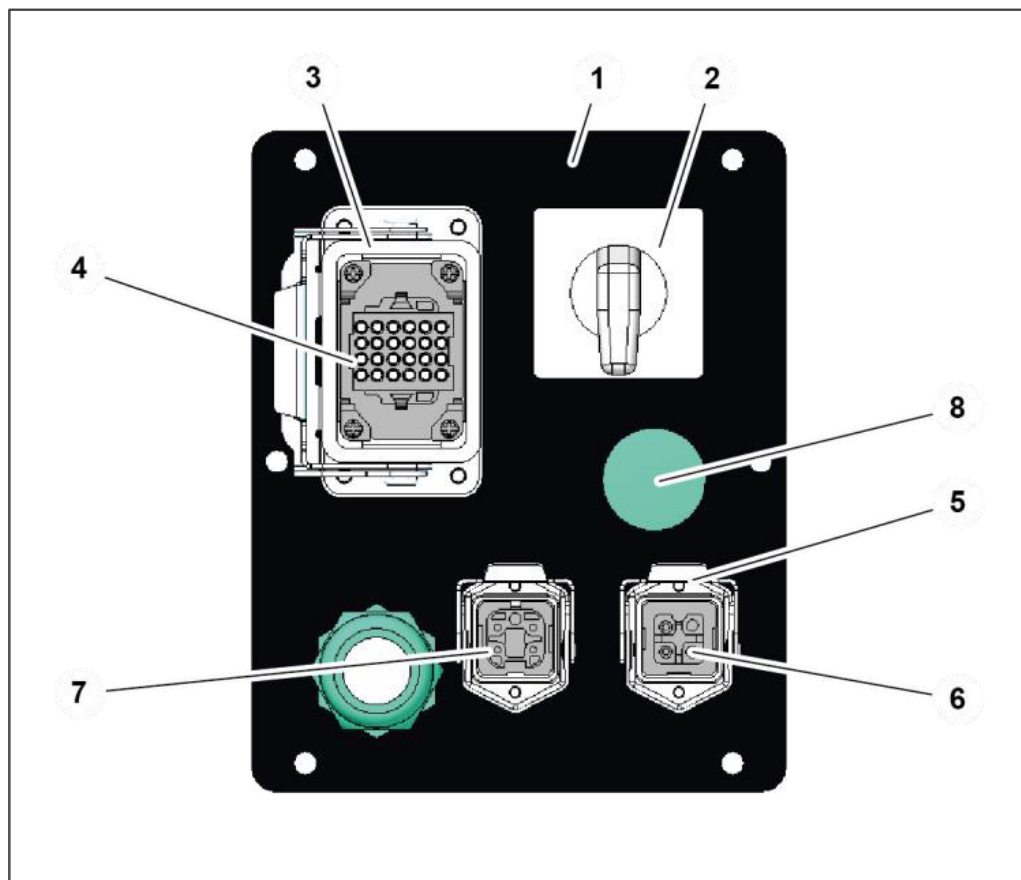

Item	Quantity	Part code	Designation
1	1	800.202.3	Mounting plate
2	1	8.06.100	Main power switch
3	1	888.223	Mounted housing
4	1	888.224	Socket insert
5	2	888.227	Mounted housing
6	1	888.228	Socket insert, 3-pin
7	1	888.229	Socket insert, 4-pin
8	1	888.498	Cover plug

### 9.3 Spare parts kit

Quantity	Part code	Designation
1 set	266.5	Pressure plate slide bearing plate, back
1 set	266.8	Bearing plate segments, front
8 per set	239.041.4 sw	Plastic retaining pin (section: 239 / 239L)



## 9 Annex

### 9.4 Service tool

---

Quantity	Part code	Designation
8 per set	239.041.4	Retaining bolt, steel (profile: 239 / 239L)
8 per set	239.151	Pressure piece (profile: 239 / 239L)
8 per set	232.504.4	Retaining bolt (profile 266)
1 set	266.11	Repair tool set









### 9.4 Service tool

Quantity	Article code	Designation
1	266.550	Mounting aid, ball nut for tool 266.1190 - S6
1	266.551	Mounting aid, ball nut for tool 266.1195 - S6S
1	266.580	Mounting aid, slide bearing plate (item 6), pressure plate, front

## 9 Annex

### 9.5 Retaining bolt for standard crimping dies (depending on crimping die)

### 9.5 Retaining bolt for standard crimping dies (depending on crimping die)

Retaining bolt	Crimping die profile									
	262	263	239	266	232	237	554	245	246	247
 262.104.4	x									
 262.129.3		x								
 239.041.4			x							
 239.041.4 (sw)			x							
 232.504.4				x	x	x				
 232.505.4					Ø96 / Ø103					
 220.502.4							x			
 245.114.4								x	x	x

## 9 Annex

### 9.5 Retaining bolt for standard crimping dies (depending on crimping die)

---

# 9 Annex

## 9.6 Hydraulic diagram

### 9.6 Hydraulic diagram

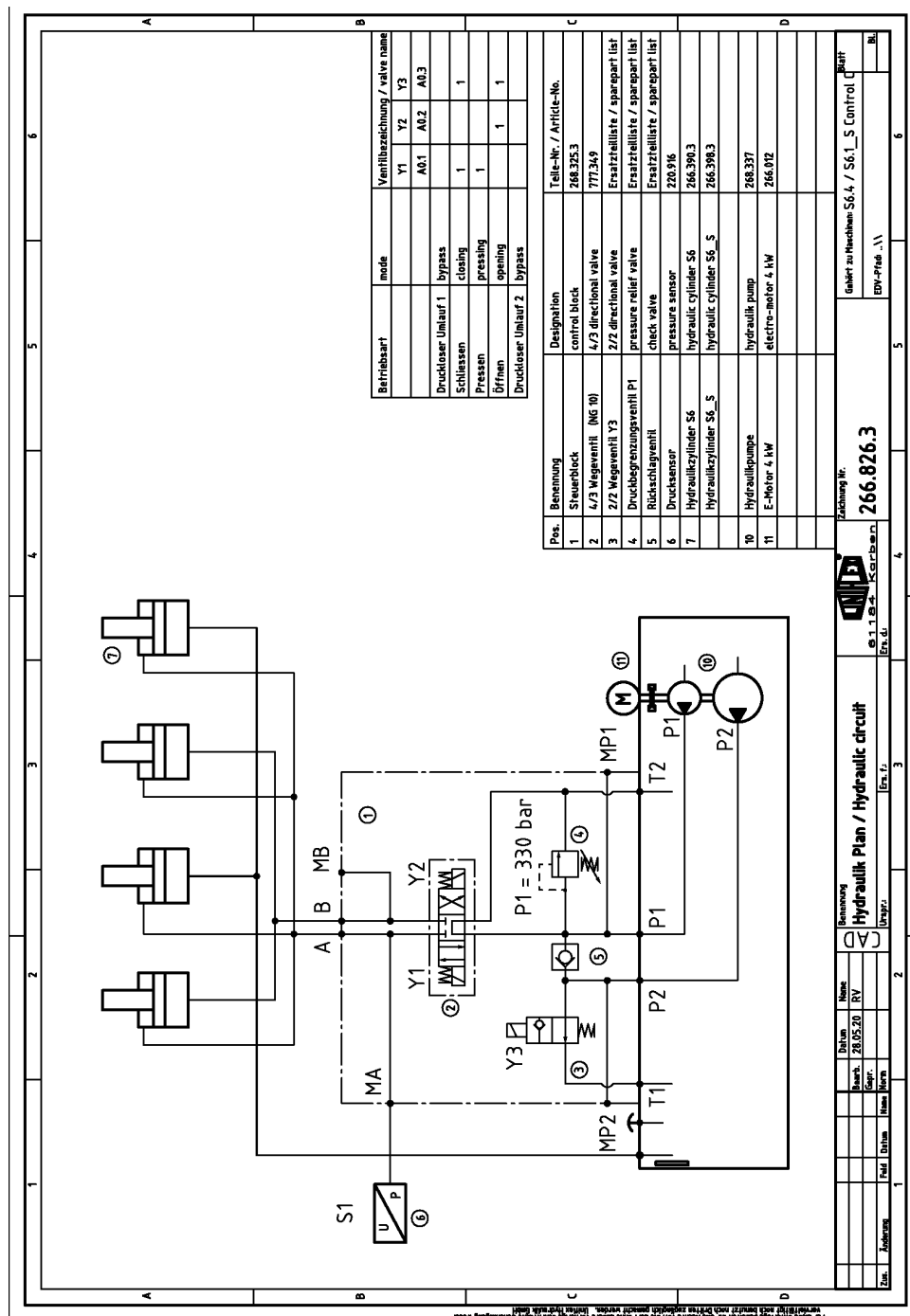

### 9.7 Electric diagram

# 9 Annex

## 9.7 Electric diagram

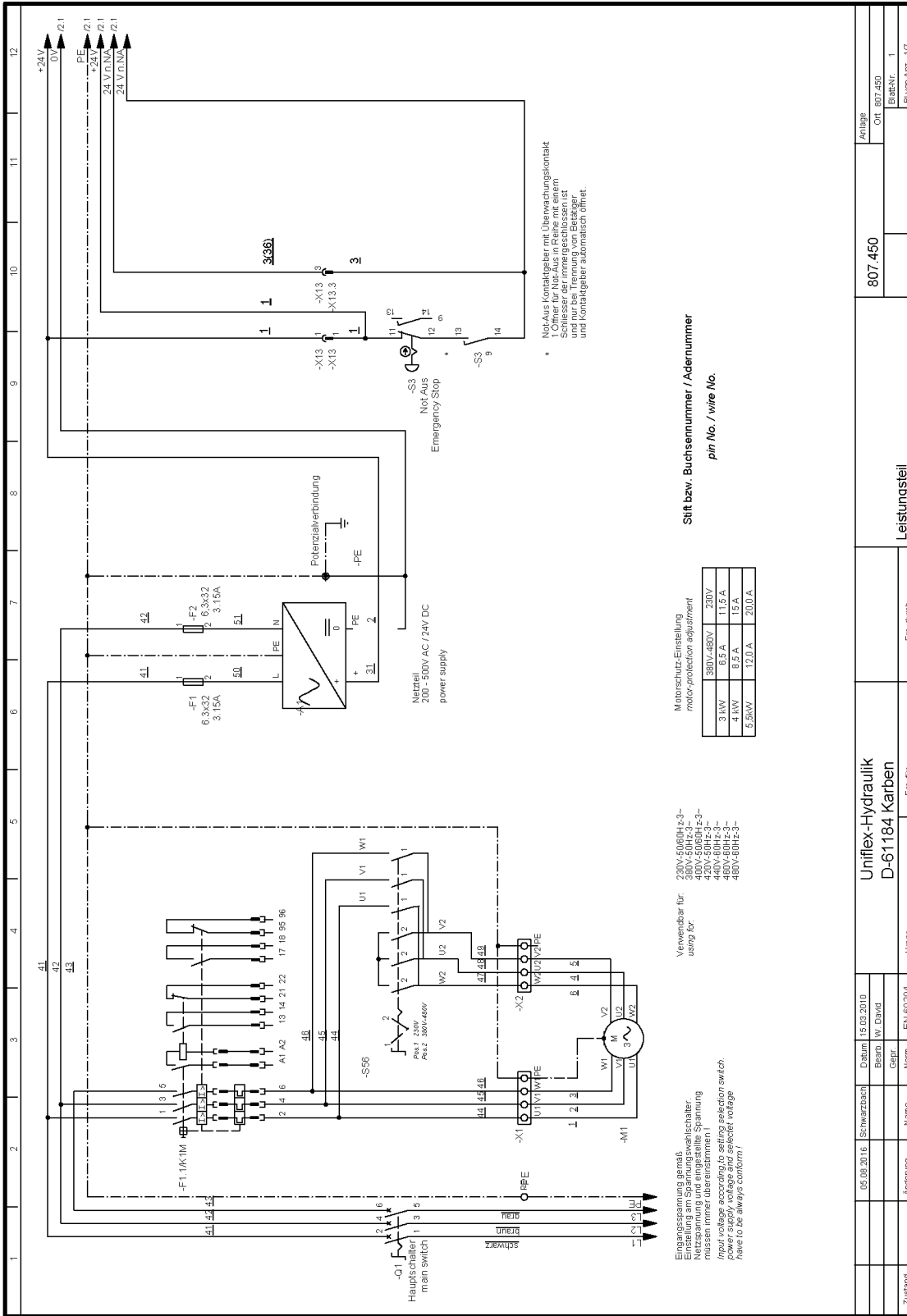

# 9 Annex

## 9.7 Electric diagram

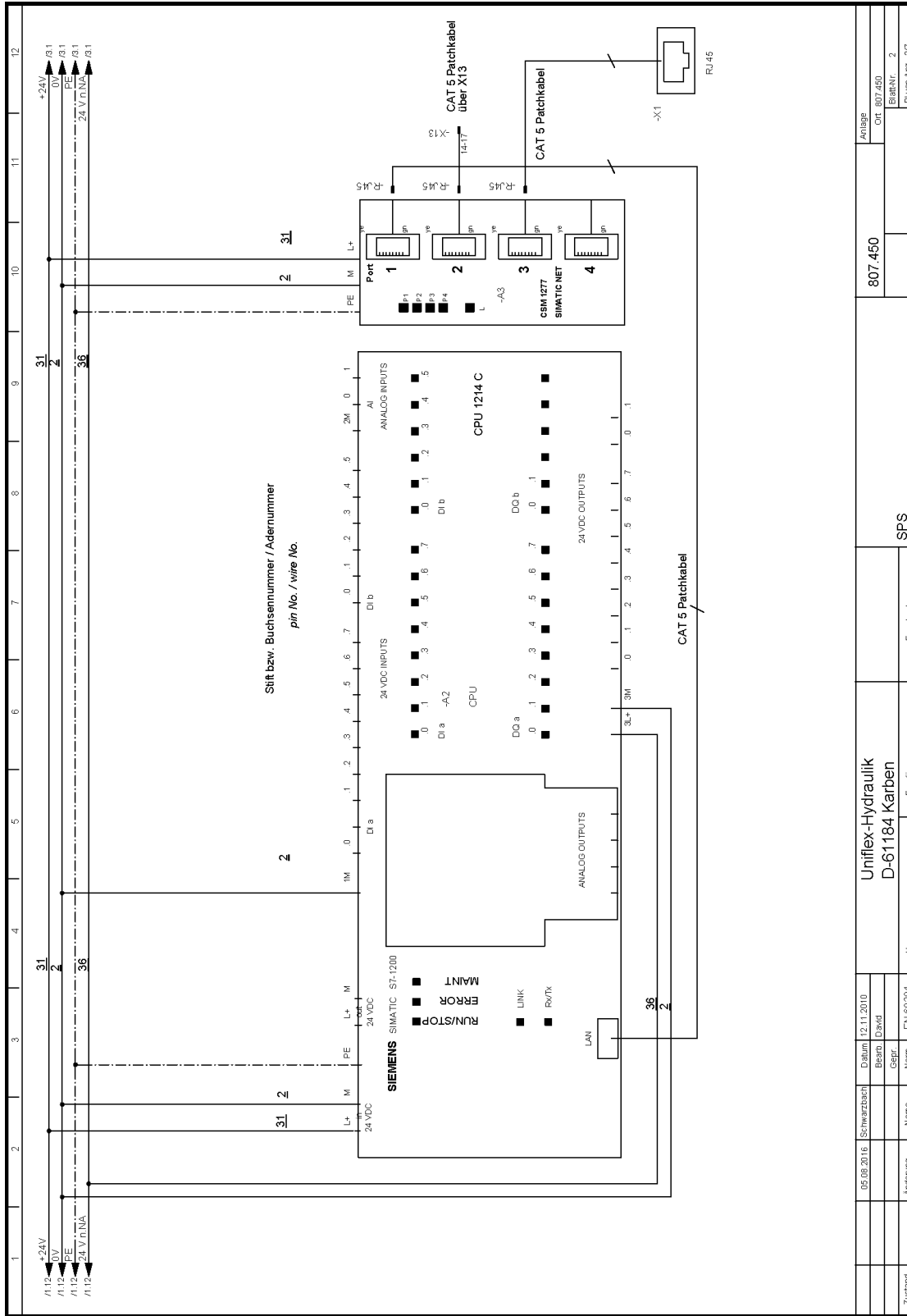

Zustand	06.08.2016	Schwarzbach	Datum	12.11.2010	Uniflex-Hydraulik		807.450		Anlage
			Beschr.	David	D-61184 Karben				Ort
			Gepr.						807.450
			Name	Norm	EN 60204	SPS		BlattNr. 2	
			Änderung	Name	Urspr.	Ers. durch		BlattAnz. 2/7	

# 9 Annex

## 9.7 Electric diagram

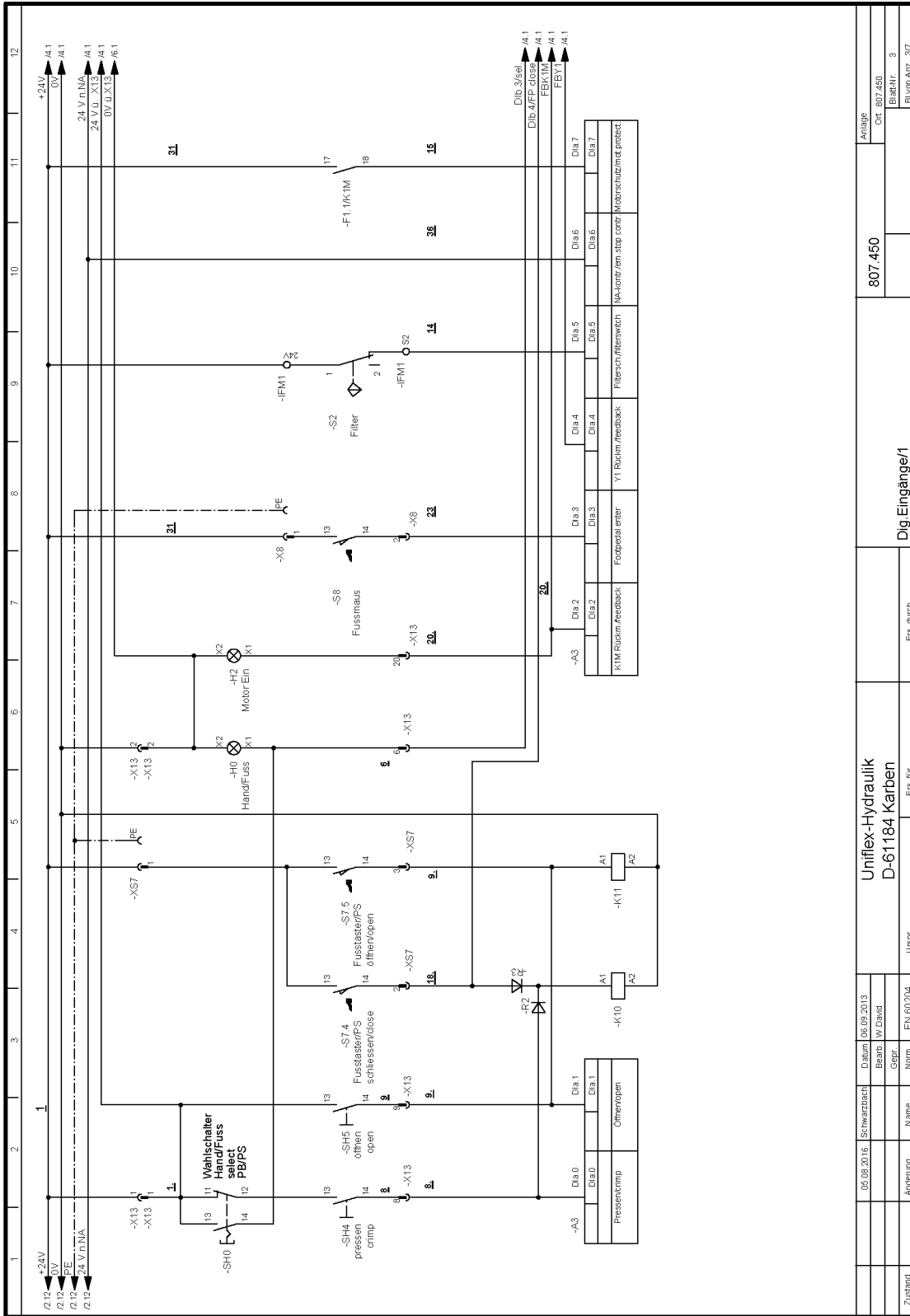

Uniflex-Hydraulik  
D-61184 Karben

Datum	05.09.2013
Bearb.	W. David
CS/Pl.	
Norm.	EN 60204
Urspr.	

Zustand	
Änderung	

807 450	807 450
Dig. Eingänge/1	
Ansage	
Dr. 607 450	
Blatt/Nr.	3
Blatt/Nr.	397

# 9 Annex

## 9.7 Electric diagram

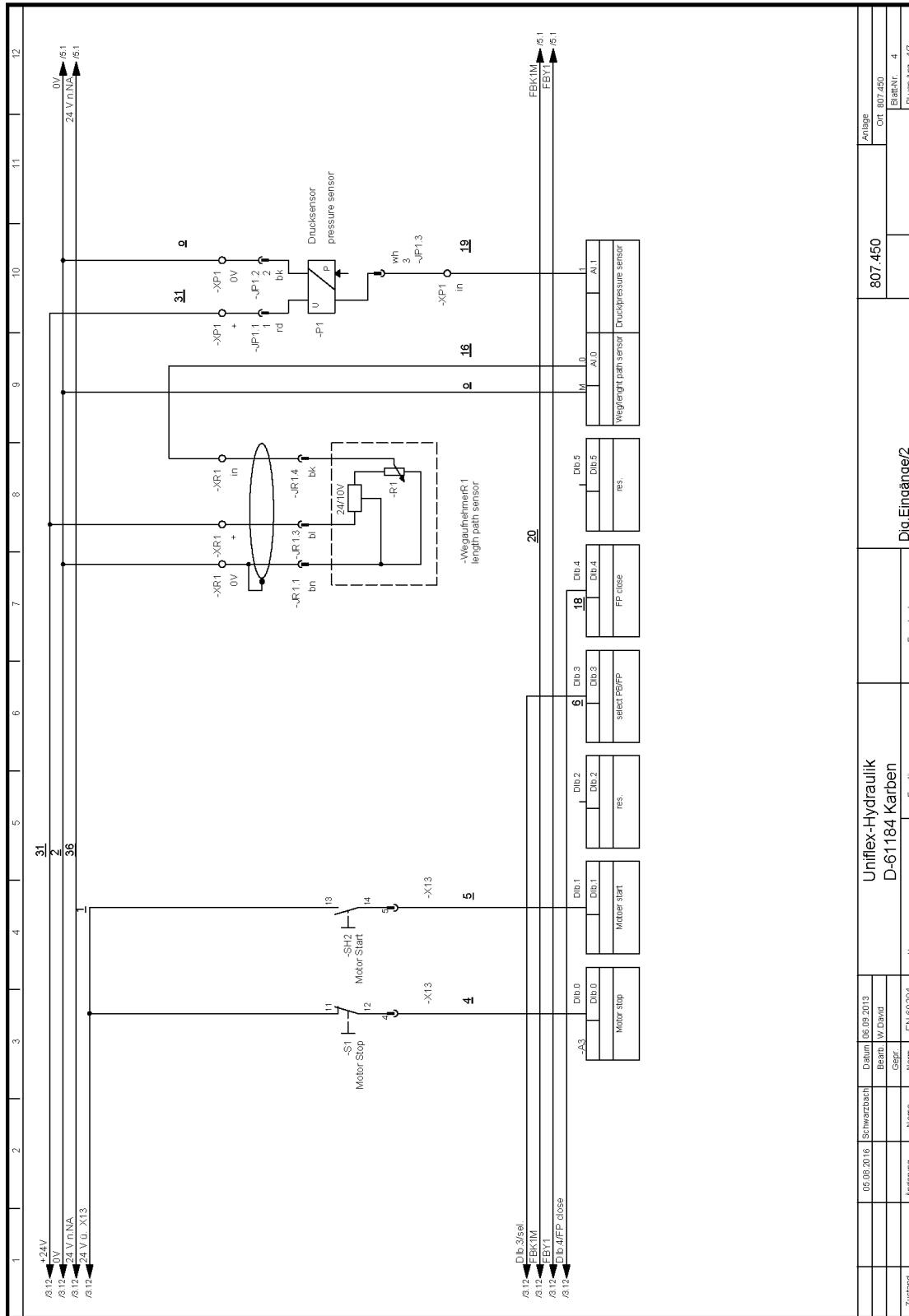



# 9 Annex

## 9.7 Electric diagram

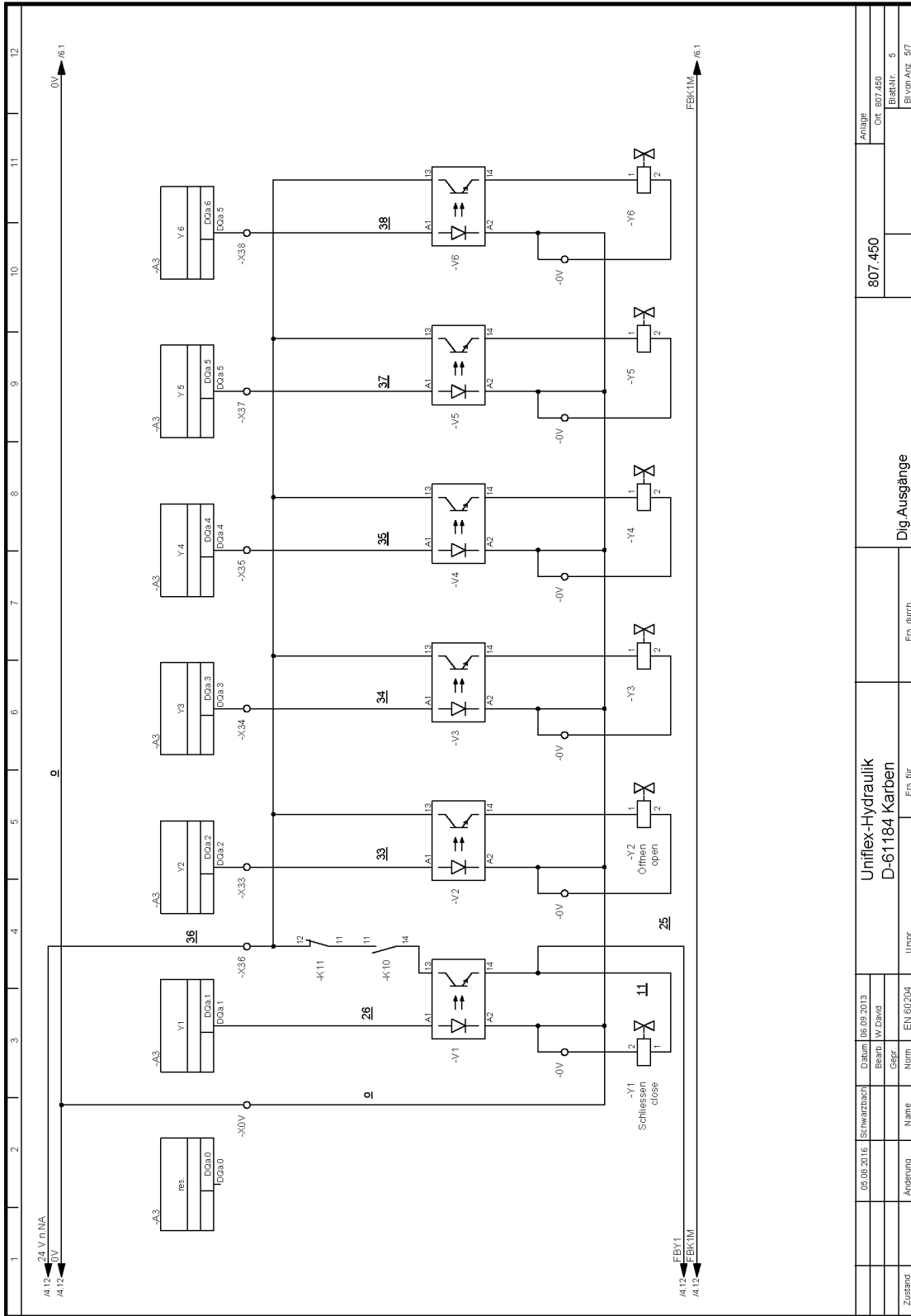

Zustand	05.08.2016	Schwarzbach	Datum	06.09.2013	Uniflex-Hydraulik	807.450	Anlage
Änderung			Bereit.	Iw David	D-61184 Karben		Dr. 807.450
Name			Gespr.				BlattNr. 5
Norm			Urspr.				Blattanz. 5/7
							Erst durch
							Erst durch

# 9 Annex

## 9.7 Electric diagram

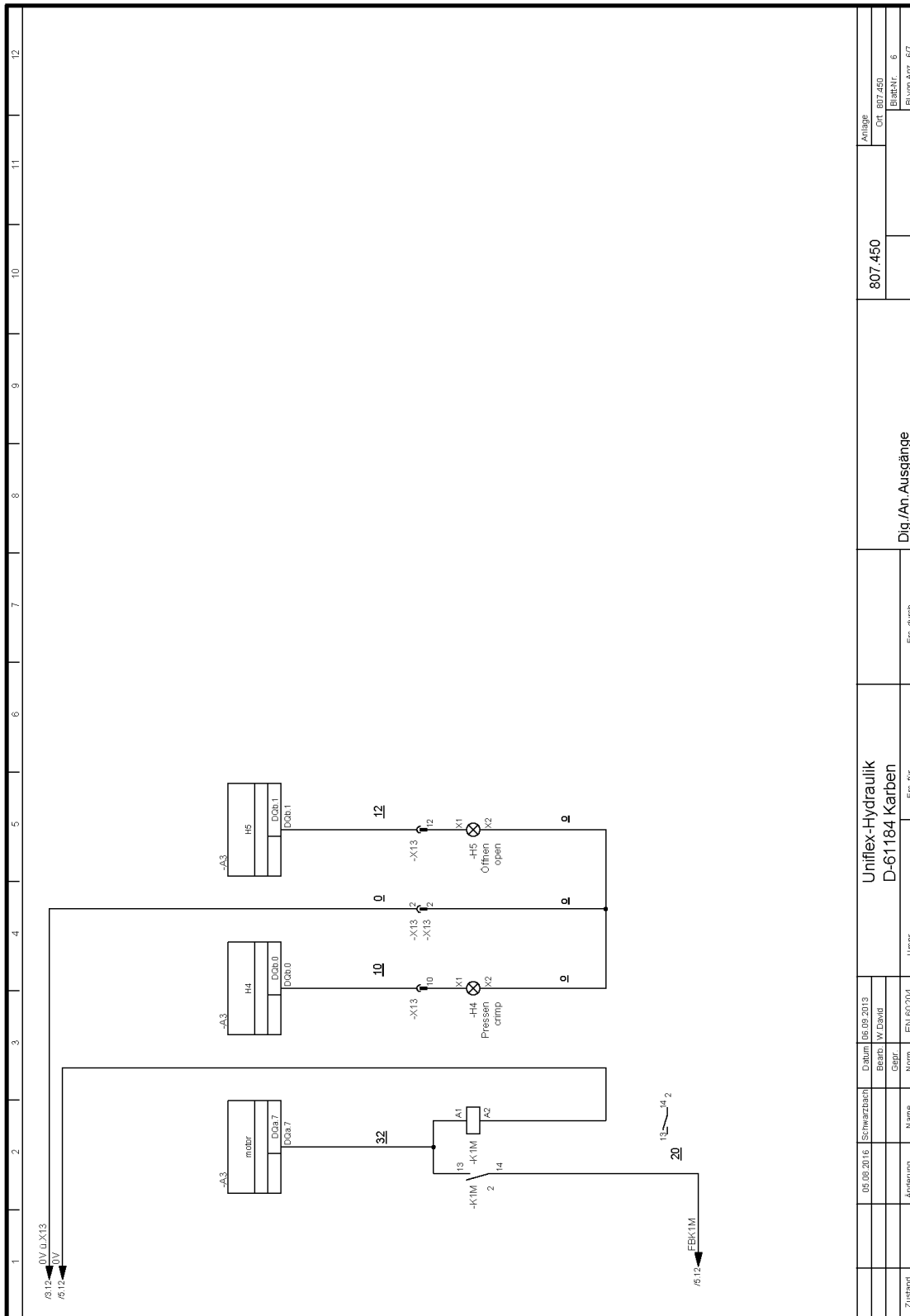

05.09.2016	Schwarzbach	Calum	06.09.2013	Uniflex-Hydraulik		807.450	Anlage
		Bened	IV David	D-61184 Karben			CH 617.051
		Gerr		Ers. für			Blatt Nr. 6
		Name	Norm	Ers. durch			Blatt Anz. 6/7
Zustand	Änderung		Unser	D/g./An./Ausgänge			
				Ers. für			

# 9 Annex

## 9.7 Electric diagram

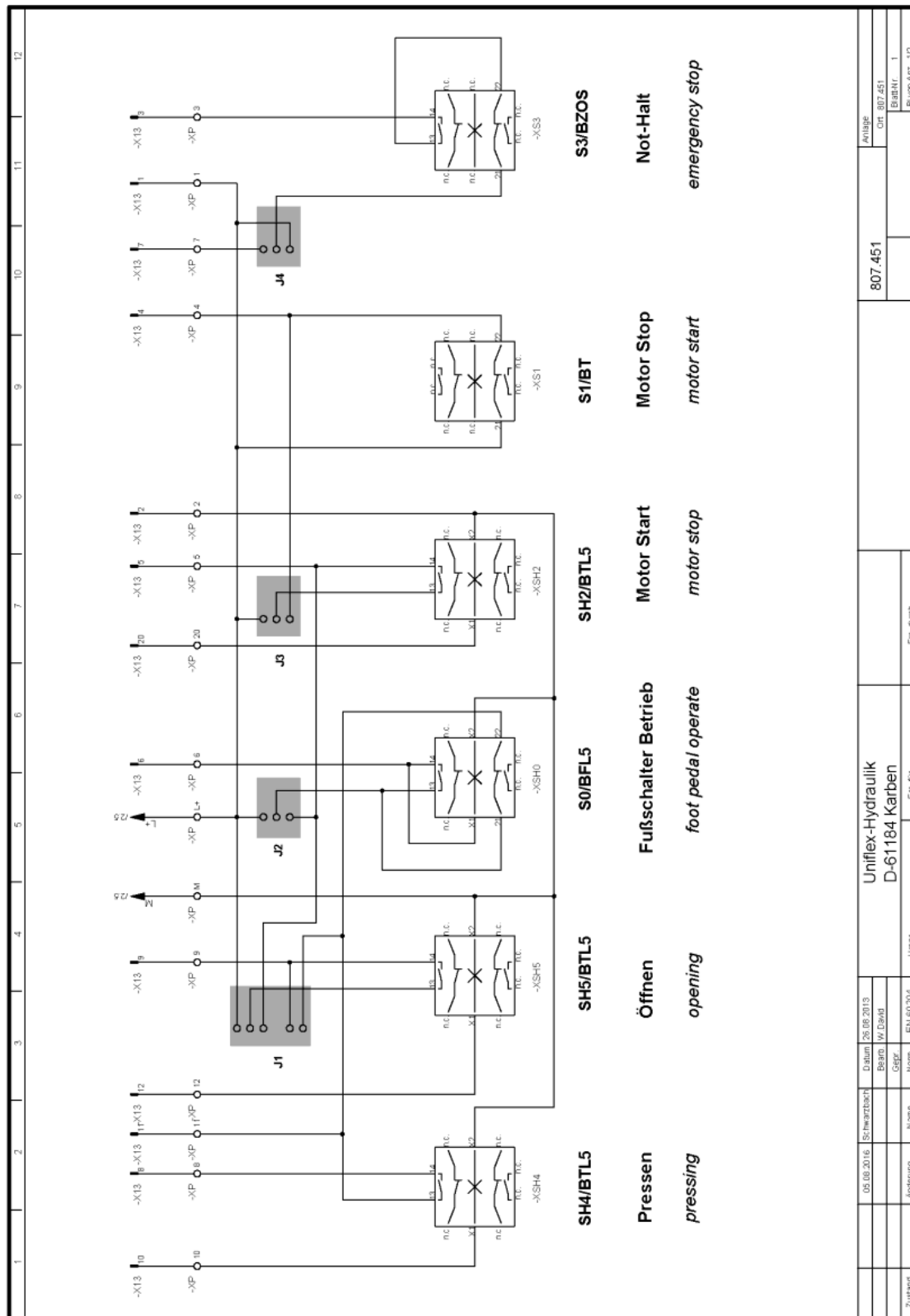

05.08.2016		Schwarzbach		Datum   26.08.2013		807.451		AVI/GE	
		Beard		Nr. David				Ort   807.451	
		CSEZ						EBA/AN   1	
		Norm   EN 60204		Unger				S. von A/S - 12	
Zustand		Abänderung		Name		Ers. für		Ers. durch	
				Uniflex-Hydraulik D-61184 Karben					

# 9 Annex

## 9.8 Maintenance log

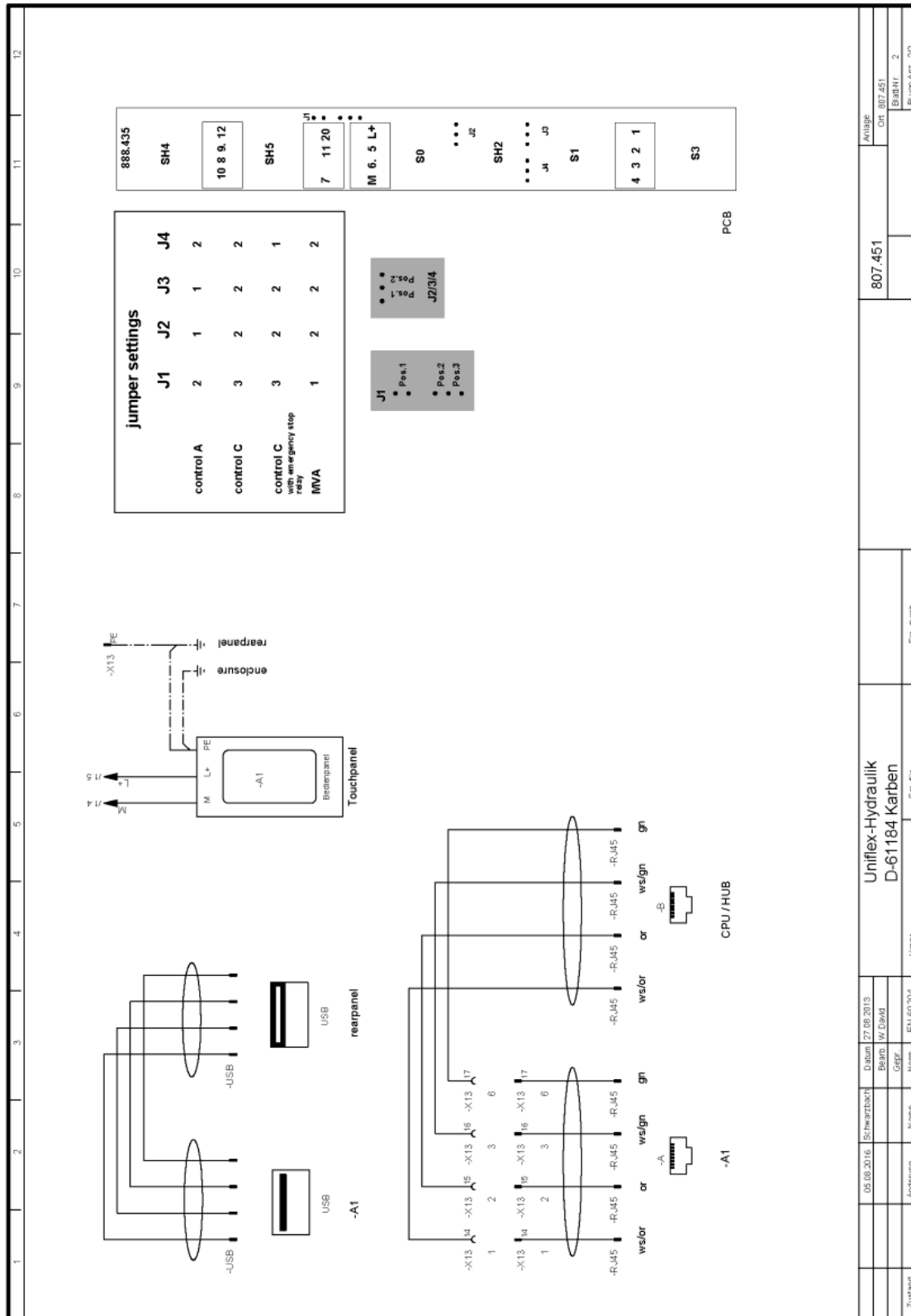

## 9.8 Maintenance log

## 9 Annex

### 9.9 Declaration of qualified staff

Hydraulic oil	Hose assembly	Retaining bolt	Slide bearing plate	Pressure springs	Guiding plate	Relay	Remark	Date	Signature
<input type="checkbox"/>	<input type="checkbox"/>	<input type="checkbox"/>	<input type="checkbox"/>	<input type="checkbox"/>	<input type="checkbox"/>	<input type="checkbox"/>			
<input type="checkbox"/>	<input type="checkbox"/>	<input type="checkbox"/>	<input type="checkbox"/>	<input type="checkbox"/>	<input type="checkbox"/>	<input type="checkbox"/>			
<input type="checkbox"/>	<input type="checkbox"/>	<input type="checkbox"/>	<input type="checkbox"/>	<input type="checkbox"/>	<input type="checkbox"/>	<input type="checkbox"/>			
<input type="checkbox"/>	<input type="checkbox"/>	<input type="checkbox"/>	<input type="checkbox"/>	<input type="checkbox"/>	<input type="checkbox"/>	<input type="checkbox"/>			
<input type="checkbox"/>	<input type="checkbox"/>	<input type="checkbox"/>	<input type="checkbox"/>	<input type="checkbox"/>	<input type="checkbox"/>	<input type="checkbox"/>			
<input type="checkbox"/>	<input type="checkbox"/>	<input type="checkbox"/>	<input type="checkbox"/>	<input type="checkbox"/>	<input type="checkbox"/>	<input type="checkbox"/>			
<input type="checkbox"/>	<input type="checkbox"/>	<input type="checkbox"/>	<input type="checkbox"/>	<input type="checkbox"/>	<input type="checkbox"/>	<input type="checkbox"/>			
<input type="checkbox"/>	<input type="checkbox"/>	<input type="checkbox"/>	<input type="checkbox"/>	<input type="checkbox"/>	<input type="checkbox"/>	<input type="checkbox"/>			
<input type="checkbox"/>	<input type="checkbox"/>	<input type="checkbox"/>	<input type="checkbox"/>	<input type="checkbox"/>	<input type="checkbox"/>	<input type="checkbox"/>			
<input type="checkbox"/>	<input type="checkbox"/>	<input type="checkbox"/>	<input type="checkbox"/>	<input type="checkbox"/>	<input type="checkbox"/>	<input type="checkbox"/>			
<input type="checkbox"/>	<input type="checkbox"/>	<input type="checkbox"/>	<input type="checkbox"/>	<input type="checkbox"/>	<input type="checkbox"/>	<input type="checkbox"/>			
<input type="checkbox"/>	<input type="checkbox"/>	<input type="checkbox"/>	<input type="checkbox"/>	<input type="checkbox"/>	<input type="checkbox"/>	<input type="checkbox"/>			
<input type="checkbox"/>	<input type="checkbox"/>	<input type="checkbox"/>	<input type="checkbox"/>	<input type="checkbox"/>	<input type="checkbox"/>	<input type="checkbox"/>			
<input type="checkbox"/>	<input type="checkbox"/>	<input type="checkbox"/>	<input type="checkbox"/>	<input type="checkbox"/>	<input type="checkbox"/>	<input type="checkbox"/>			
<input type="checkbox"/>	<input type="checkbox"/>	<input type="checkbox"/>	<input type="checkbox"/>	<input type="checkbox"/>	<input type="checkbox"/>	<input type="checkbox"/>			
<input type="checkbox"/>	<input type="checkbox"/>	<input type="checkbox"/>	<input type="checkbox"/>	<input type="checkbox"/>	<input type="checkbox"/>	<input type="checkbox"/>			
<input type="checkbox"/>	<input type="checkbox"/>	<input type="checkbox"/>	<input type="checkbox"/>	<input type="checkbox"/>	<input type="checkbox"/>	<input type="checkbox"/>			
<input type="checkbox"/>	<input type="checkbox"/>	<input type="checkbox"/>	<input type="checkbox"/>	<input type="checkbox"/>	<input type="checkbox"/>	<input type="checkbox"/>			
<input type="checkbox"/>	<input type="checkbox"/>	<input type="checkbox"/>	<input type="checkbox"/>	<input type="checkbox"/>	<input type="checkbox"/>	<input type="checkbox"/>			
<input type="checkbox"/>	<input type="checkbox"/>	<input type="checkbox"/>	<input type="checkbox"/>	<input type="checkbox"/>	<input type="checkbox"/>	<input type="checkbox"/>			
<input type="checkbox"/>	<input type="checkbox"/>	<input type="checkbox"/>	<input type="checkbox"/>	<input type="checkbox"/>	<input type="checkbox"/>	<input type="checkbox"/>			
<input type="checkbox"/>	<input type="checkbox"/>	<input type="checkbox"/>	<input type="checkbox"/>	<input type="checkbox"/>	<input type="checkbox"/>	<input type="checkbox"/>			
<input type="checkbox"/>	<input type="checkbox"/>	<input type="checkbox"/>	<input type="checkbox"/>	<input type="checkbox"/>	<input type="checkbox"/>	<input type="checkbox"/>			
<input type="checkbox"/>	<input type="checkbox"/>	<input type="checkbox"/>	<input type="checkbox"/>	<input type="checkbox"/>	<input type="checkbox"/>	<input type="checkbox"/>			
<input type="checkbox"/>	<input type="checkbox"/>	<input type="checkbox"/>	<input type="checkbox"/>	<input type="checkbox"/>	<input type="checkbox"/>	<input type="checkbox"/>			
<input type="checkbox"/>	<input type="checkbox"/>	<input type="checkbox"/>	<input type="checkbox"/>	<input type="checkbox"/>	<input type="checkbox"/>	<input type="checkbox"/>			
<input type="checkbox"/>	<input type="checkbox"/>	<input type="checkbox"/>	<input type="checkbox"/>	<input type="checkbox"/>	<input type="checkbox"/>	<input type="checkbox"/>			
<input type="checkbox"/>	<input type="checkbox"/>	<input type="checkbox"/>	<input type="checkbox"/>	<input type="checkbox"/>	<input type="checkbox"/>	<input type="checkbox"/>			
<input type="checkbox"/>	<input type="checkbox"/>	<input type="checkbox"/>	<input type="checkbox"/>	<input type="checkbox"/>	<input type="checkbox"/>	<input type="checkbox"/>			
<input type="checkbox"/>	<input type="checkbox"/>	<input type="checkbox"/>	<input type="checkbox"/>	<input type="checkbox"/>	<input type="checkbox"/>	<input type="checkbox"/>			
<input type="checkbox"/>	<input type="checkbox"/>	<input type="checkbox"/>	<input type="checkbox"/>	<input type="checkbox"/>	<input type="checkbox"/>	<input type="checkbox"/>			
<input type="checkbox"/>	<input type="checkbox"/>	<input type="checkbox"/>	<input type="checkbox"/>	<input type="checkbox"/>	<input type="checkbox"/>	<input type="checkbox"/>			

### 9.9 Declaration of qualified staff

I herewith declare that I have attended an internal training for the operation of the UNIFLEX machine and have been informed on all

## 9 Annex

### 9.9 Declaration of qualified staff

---

safety-related details. In addition I declare that I have read and understood this Operation Manual completely.

City	Date	Name	Signature

City	Date	Name	Signature

City	Date	Name	Signature

City	Date	Name	Signature

City	Date	Name	Signature

City	Date	Name	Signature

## 9 Annex

### 9.9 Declaration of qualified staff

---

## About Danfoss Power Solutions FC

We sincerely appreciate your choice in selecting this product as part of the range of tooling products distributed by Danfoss.

Danfoss hoses, fittings, and tooling provide the ultimate fluid conveyance solutions for a variety of equipment and applications around the world. We proudly engineer to support a sustainable future for tomorrow.

To learn more please visit: <http://www.danfoss.com/en/about-danfoss/our-businesses/power-solutions>

### **Danfoss Power Solutions**

14615 Lone Oak Road  
Eden Prairie, MN 55344, USA  
Phone: 952-937-9800

### **Danfoss Power Solutions II GmbH**

Fluid Conveyance  
Dr. -Reckeweg-Str. 1  
DE-76532 Baden-Baden  
Tel.: +49 7221 6820  
Machine and tooling selection hotline: [FcMachineSupportEMEA@danfoss.com](mailto:FcMachineSupportEMEA@danfoss.com)  
Service and repair Hotline: [FcMachineRepairsEMEA@danfoss.com](mailto:FcMachineRepairsEMEA@danfoss.com)

### **Danfoss Power Solutions (US) Company**

2800 East 13th Street  
Ames, IA 50010, USA  
Phone: +1 515-239-6000

### **Danfoss Power Solutions GmbH & Co.OHG**

Krokamp 35  
D-2439 Neumünster, Germany  
Phone: +49 4321 871 0

### **Danfoss Power Solutions ApS**

Nordborgvej 81  
DK-6430 Nordborg, Denmark  
Phone: +45 7488 2222

### **Danfoss Power Solutions Trade (Shanghai) Co. Ltd.**

Building #22, No 1000 Jin Hai Rd  
Jin Qiao, Pudong New District  
Shanghai, China 201206  
Phone: +86 21 3418 5200w

Thank you for participating in the Danfoss tooling program. We are pleased to offer you high-quality tooling machines manufactured by our trusted partner, Uniflex. These machines are designed to meet the rigorous standards of our industry, ensuring reliability, precision, and efficiency in your operations. We are committed to providing you with the best tools to support your success.