

ENGINEERING  
TOMORROW

*Danfoss*

Operator's Manual

# ET4200 Crimping Machine

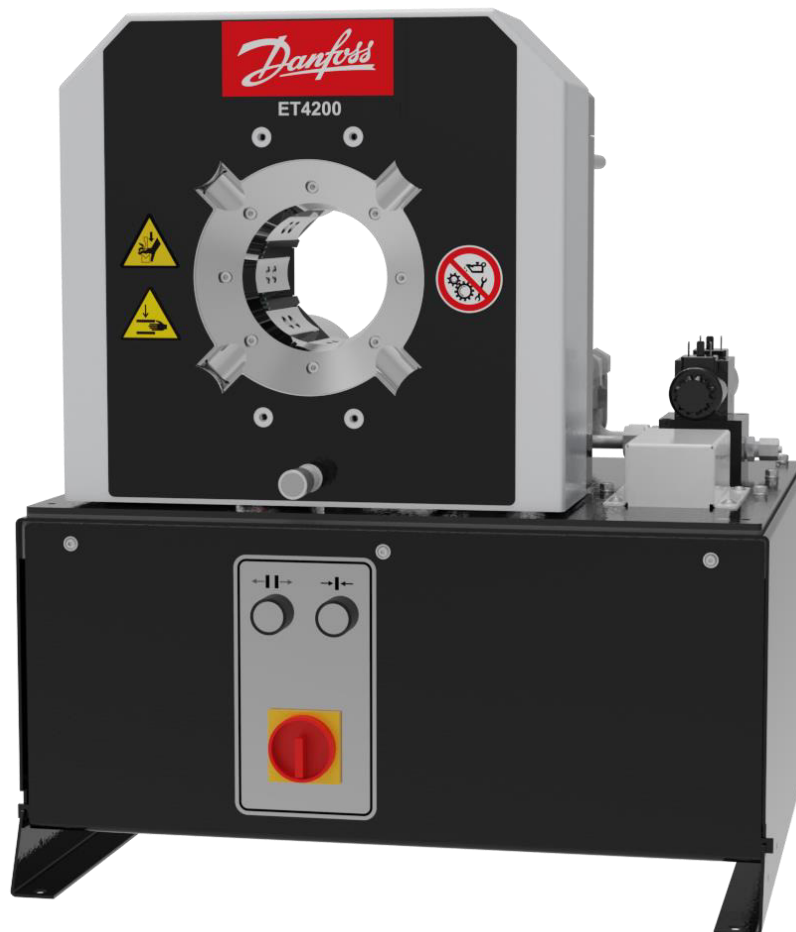

## Imprint

**Manufacturer:**

UNIFLEX-Hydraulik GmbH  
Robert-Bosch-Strasse 50-52  
D-61184 Karben  
Germany

Phone: +49 (0) 60 39 / 91 71 - 0  
Fax: +49 (0) 60 39 / 91 71 - 181

**This Operating Manual of the machine is a translation; the original is in German.**

**Date of revision: 2024-07-18**

**Version: 1.1**

© Copyright by UNIFLEX-Hydraulik GmbH

Technical modifications reserved.

The reproduction, distribution and utilization of this document as well as the communication of its contents to others without explicit authorization are prohibited. Offenders will be held liable for the payment of damages. All rights reserved in the event of the grant of a patent, utility model or design.

## EC / UK - Declaration of Conformity

In accordance with EC Machinery Directive 2006/42/EC and UK-Supply of Machinery (Safety) Regulations 2008.

The following machine

ET4200

was developed, designed and manufactured in compliance with EC Directive 2006/42/EC and UK-Supply of Machinery (Safety) Regulations 2008, in the sole responsibility of

UNIFLEX-Hydraulik GmbH  
Robert-Bosch-Strasse 50 - 52  
D-61184 Karben

The following standards, codes and specifications have been applied:

- EC Directive 2006/42/EC
- EMC Directive 2014/30/EC
- EN ISO 12100: 2010
- EN 60204-1: 2018
- UK-Supply of Machinery (Safety) Regulations 2008
- UK-Electromagnetic Compatibility Regulations 2016

This declaration are invalid when the machine is modified or if unauthorized and unapproved third-party components are used without our prior approval.

Entity authorised for documentation: Uniflex-Hydraulik GmbH, Technical Documentation Dept.

Karben, 25.02.2021



Managing Director Harald von Waitz

# Contents

|          |                                       |           |
|----------|---------------------------------------|-----------|
| <b>1</b> | <b>About this document</b>            | <b>7</b>  |
| 1.1      | Target groups                         | 7         |
| 1.2      | Storage                               | 9         |
| 1.3      | Name plate                            | 9         |
| 1.4      | Abbreviations                         | 9         |
| 1.5      | Voltage codes                         | 9         |
| <b>2</b> | <b>Safety instructions</b>            | <b>10</b> |
| 2.1      | Presentation of warnings              | 10        |
| 2.2      | Intended use                          | 10        |
| 2.3      | Product-specific risks                | 11        |
| 2.3.1    | Risks imposed by mechanical equipment | 12        |
| 2.3.2    | Risks imposed by electricity          | 12        |
| 2.3.3    | Risks imposed by hydraulic equipment  | 12        |
| 2.3.4    | Risks imposed by noise                | 13        |
| 2.3.5    | Risks imposed by substances           | 13        |
| 2.3.6    | Risk by hot surfaces                  | 13        |
| 2.3.7    | Risks in case of fire                 | 13        |
| 2.4      | Safety                                | 14        |
| 2.4.1    | Working area                          | 14        |
| 2.4.2    | Emergency-Stop                        | 14        |
| 2.4.3    | Protection equipment                  | 15        |
| 2.4.4    | Warning signs on the machine          | 16        |
| <b>3</b> | <b>Machine description</b>            | <b>18</b> |
| 3.1      | Design and function                   | 18        |
| 3.2      | Accessories                           | 19        |
| 3.3      | Forming process                       | 19        |
| 3.4      | Operation and display elements        | 21        |
| 3.5      | Depth stop (accessory)                | 21        |
| 3.6      | Technical data                        | 23        |
| <b>4</b> | <b>Transport and commissioning</b>    | <b>26</b> |
| 4.1      | Transport                             | 26        |
| 4.2      | Intermediate storage of machine/unit  | 27        |
| 4.3      | Commissioning                         | 27        |

## Contents

---

|          |   |           |
|----------|---|-----------|
| 4.3.1    | Filling hydraulic oil .....   | 28        |
| 4.3.2    | Electrical connection .....   | 30        |
| 4.3.3    | Bleeding the hydraulic system .....   | 31        |
| <b>5</b> | <b>Operation .....</b>  | <b>32</b> |
| 5.1      | What you have to observe .....  | 32        |
| 5.2      | Start .....   | 32        |
| 5.3      | Forming the workpiece.....  | 33        |
| 5.3.1    | Prerequisites.....  | 33        |
| 5.3.2    | Operation mode buttons control panel.....   | 33        |
| 5.3.3    | Changing the crimping dies with the quick die change system (only profile 239)..... | 34        |
| 5.4      | Adjusting the depth stop .....  | 37        |
| 5.5      | Setting the forming dimension .....   | 39        |
| 5.6      | Forming travel limitation .....   | 39        |
| 5.7      | Stop .....  | 40        |
| 5.8      | Emergency stop.....   | 41        |
| 5.9      | Cleaning.....   | 41        |
| <b>6</b> | <b>Maintenance.....</b>   | <b>43</b> |
| 6.1      | What you have to observe .....  | 43        |
| 6.2      | Maintenance schedule .....  | 43        |
| 6.3      | Hydraulic oil change.....   | 45        |
| 6.4      | Checking and replacing slide bearing plates.....                                    | 47        |
| 6.5      | Micrometer adjustment .....   | 49        |
| <b>7</b> | <b>Troubleshooting .....</b>  | <b>50</b> |
| <b>8</b> | <b>Decommissioning, disposal .....</b>  | <b>51</b> |
| 8.1      | Dismantling .....   | 52        |
| 8.2      | Recycling .....   | 52        |
| 8.3      | Consumables and waste.....  | 52        |
| <b>9</b> | <b>Annex .....</b>  | <b>53</b> |
| 9.1      | Machine overview .....  | 54        |
| 9.2      | Accessories (retrofitable) .....  | 55        |
| 9.3      | Spare parts list.....   | 56        |
| 9.3.1    | Tool.....   | 56        |
| 9.3.2    | Mechanical equipment.....   | 57        |
| 9.3.3    | Hydraulic system .....  | 58        |
| 9.3.4    | Electric equipment.....   | 59        |

## Contents

---

|      |   |    |
|------|---|----|
| 9.4  | Spare parts kit .....   | 60 |
| 9.5  | Service tool.....   | 61 |
| 9.6  | Retaining bolt for standard crimping dies (depending on crimping die) ..... | 62 |
| 9.7  | Hydraulic diagram.....  | 64 |
| 9.8  | Electric diagram.....   | 64 |
| 9.9  | Maintenance log .....   | 69 |
| 9.10 | Declaration of qualified staff .....  | 70 |

# 1 About this document

## 1.1 Target groups

---

# 1 About this document

In this Operation Manual, the “forming machine ET4200” is consistently referred to as machine.

This Operation Manual includes important notes on how you operate your machine/unit safely, properly and economically.

Use not in compliance with the intended purpose may result in hazard to the operator's health and life and/or in the risk of damage to/the machine/unit. Consequently, please only use the machine/unit

- in good order and condition,
- in accordance with its intended purpose,
- in a safety-conscious manner, with awareness of risks and hazards,
- in compliance with all notes included in this Operation Manual.

The machine/unit may only be operated by staff who

- has read the Operation Manual,
- has understood it,
- has been instructed in the operation of the machine/unit, and
- has signed in the Annex.



Figures may include accessories/options. Customer-specific equipment may vary.

The product images shown are for reference only and may differ from the product delivered.

## 1.1 Target groups

The target groups of this Operation Manual are:

### Owner

An owner is a natural person or entity using the device himself/herself/itself, or on whose behalf the device is used. An owner may appoint a representative to exercise the owner's rights and obligations.

The owner has to make sure that

# 1 About this document

## 1.1 Target groups

---

- national provisions, occupational safety regulations and applicable environmental protection regulations are fully complied with;
- persons working on the machine/unit are adequately qualified;
- persons working on the machine/unit are suitable for operating the machine/unit;
- the Operation Manual has been read and understood. One hardcopy of the Operation Manual must always be kept at a designated place where the machine/unit is used.
- persons working on the machine/unit are aware of potential risks;
- the operating staff is familiar with the location as well as with operating the fire alarm and fighting means. Free access to this equipment must be ensured.
- personal protection equipment is worn (safety footwear, protection gloves and safety glasses).

### **Machine/unit fitters**

Machine/unit fitters must be at least 18 years old and have completed training for the task, i.e. they must have attended a specialist vocational training.

#### A fitter

- must observe the instructions in the Operation Manual;
- must inform the owner on failures and damage.

### **Operator**

An operator is a person charged with and instructed in the proper operation of the machine/unit by the owner or the otherwise contractually obliged person.

#### The operator

- must observe the instructions in the Operation Manual;
- must inform the owner on failures and damage.
- must not perform and maintenance or repair work on the machine/unit.



# 1 About this document

## 1.2 Storage

---

### 1.2 Storage

The Operation Manual is part of the machine/unit and must be kept near the machine/unit at all times. Upon disposal of the machine/unit, the Operation Manual must also be handed over.

### 1.3 Name plate

The name plate is fixed near the power cable.

### 1.4 Abbreviations

|     |                                  |
|-----|----------------------------------|
| CFM | Crimp Force Monitoring           |
| FD  | Manual Flow Divider              |
| PB  | Crimping dies                    |
| PBK | Calibration crimping dies        |
| PFC | Pressure Force Control           |
| PFM | Pressure Force Monitoring        |
| QDC | Quick crimping die change system |
| ZWB | Intermediate dies                |

### 1.5 Voltage codes

| Voltage variant | Voltage rating              |
|-----------------|-----------------------------|
| -230            | 230 V – 50/60 Hz – 1 phase  |
| -380            | 380 V – 50/60 Hz – 3 phases |



The machine voltage is indicated on the name plate.

## 2 Safety instructions

### 2.1 Presentation of warnings

Warning notes in the Operation Manual warn against risks involved with the handling of the machine/unit. Risk levels are identified as follows:

**HAZARD!**

The signal word HAZARD identifies an imminent hazard resulting in serious injuries or death. This warning is supplemented by a triangular hazard symbol.

**WARNING!**

The signal word WARNING identifies a potentially hazardous situation, which might result in serious injuries or death. This warning is supplemented by a triangular hazard symbol.

**CAUTION!**

The signal word CAUTION identifies a potentially hazardous situation, which might result in light injuries. This warning is supplemented by a triangular hazard symbol.

**ATTENTION!**

The signal word ATTENTION identifies a potentially hazardous situation, in which the product or property in the environment may be damaged. This warning is supplemented by a hazard symbol or an exclamation mark.

### 2.2 Intended use

This machine is a forming machine for industrial use, only suitable for the manufacture of hose connections with a permissible diameter depending on the fitting and the hose thickness, see “Technical Data” in Section 3.

Intended purposes include:

- single workplace for one person only,
- single stroke with manual feed and withdrawal,
- for maximum hydraulic operating pressure, see “Technical Data” in Section 3.
- operating temperature between 10 °C and 35 °C,
- operation in a closed room,
- use of eight identical original UNIFLEX dies with the same label or seven dies and one associated marking crimping die.

## 2 Safety instructions

### 2.3 Product-specific risks

---

- The machine must not be operated by persons not capable of operating the machine without any risk. These may include:
  - persons with physical or mental disabilities;
  - children and persons under age;
  - persons with a restricted capability for the operation of machines (e.g. under the influence of drugs, alcohol or narcotics)

Use of the control in compliance with the intended purpose also includes compliance with the instructions in this Operation Manual.

#### **Use for other than the intended purpose**

Any other use is considered as being not in compliance with the intended purpose, in particular:

- design modification of the machine;
- use in explosive environments;
- forming of non-metal workpieces without specific safeguards approved by UNIFLEX;
- misuse of consumables and waste materials.

In particular non-metal workpieces may be overstressed by the forming process so that this may result in a sudden failure. Chips or seriously accelerated workpiece parts impose a high risk potential for operators, individuals and objects, even outside the working area.

#### **WARNING!**



#### **Risk for life and health!**

Use not in compliance with the intended purpose imposes risks for life and health. Consequences resulting from use for other than the intended purpose shall be under the sole responsibility of the owner.

- Always use the machine in compliance with its intended purpose.

### 2.3 Product-specific risks

The machine/unit is designed in accordance with the latest state of technology. Nevertheless, the machine/unit may impose risks:

---

## 2 Safety instructions

### 2.3 Product-specific risks

---

#### 2.3.1 Risks imposed by mechanical equipment

##### **Risk of squeezing**

When the die system closes, there is a risk of getting squeezed between the die and the workpiece.

- Keep the feed opening for the workpiece as small as possible.
- Keep sufficient distance to the die system.

##### **Tilting hazard**

The risk of tilting mainly exists while the machine is being transported.

- Observe the machine's centre of gravity during transport.

#### 2.3.2 Risks imposed by electricity

There is a risk of electrocution near the live parts!

- Work on electric systems may only be performed by qualified electricians or instructed and trained persons under the supervision of a qualified electrician.
- Deactivate the machine/unit and secure it against unintentional restart before maintenance.

#### 2.3.3 Risks imposed by hydraulic equipment

Risks are imposed by all hydraulic lines and connections. Hydraulic systems are subject to special safety provisions. Work on hydraulic equipment may only be performed by persons with expert knowledge of and experience with hydraulic equipment.

- After the machine/unit is deactivated, the given and potentially hazardous residual energy has to be considered.
- Relieve the residual pressure in the system before performing repair or maintenance work on hydraulic systems.
- Regularly check lines and bolted connections for leaks and visible damage. Immediately remedy any damage detected.

Repair work on the hydraulic system of the machine/unit or on its components may only be performed by UNIFLEX specialist staff.

## 2 Safety instructions

### 2.3 Product-specific risks

---

#### 2.3.4 Risks imposed by noise

The noise level meter acc. to IEC 804, Class 2, was calibrated before measuring.

The operation of the machine/unit causes noise emissions of < 70 dB(A) at the workplace. Noise protection is not required.

Higher noise emissions may occur when other machine/unit is simultaneously used at the workplace. The machine/unit owner must provide for appropriate protection, e.g.

- instruct staff to wear ear protection,
- provide information/instructions on risks,
- identify hazardous areas,
- provide health monitoring.

#### 2.3.5 Risks imposed by substances

Oils, greases and emulsions may penetrate the skin. When handling hazardous substances, oils and greases, the manufacturers' safety instructions have to be observed. Apply skin protection appropriate for the hazardous substances used.

#### 2.3.6 Risk by hot surfaces

There is a risk of burning when touching the workpiece after forming.

- Wear protection gloves.

#### 2.3.7 Risks in case of fire

The operating staff has to be familiar with the location as well as with operating the fire alarm and fighting means. Free access to this equipment must be ensured.

Never use water to extinguish a fire. For appropriate fire extinguishing action, please read the safety data sheet of the hydraulic oil supplier.

## 2.4 Safety

### 2.4.1 Working area

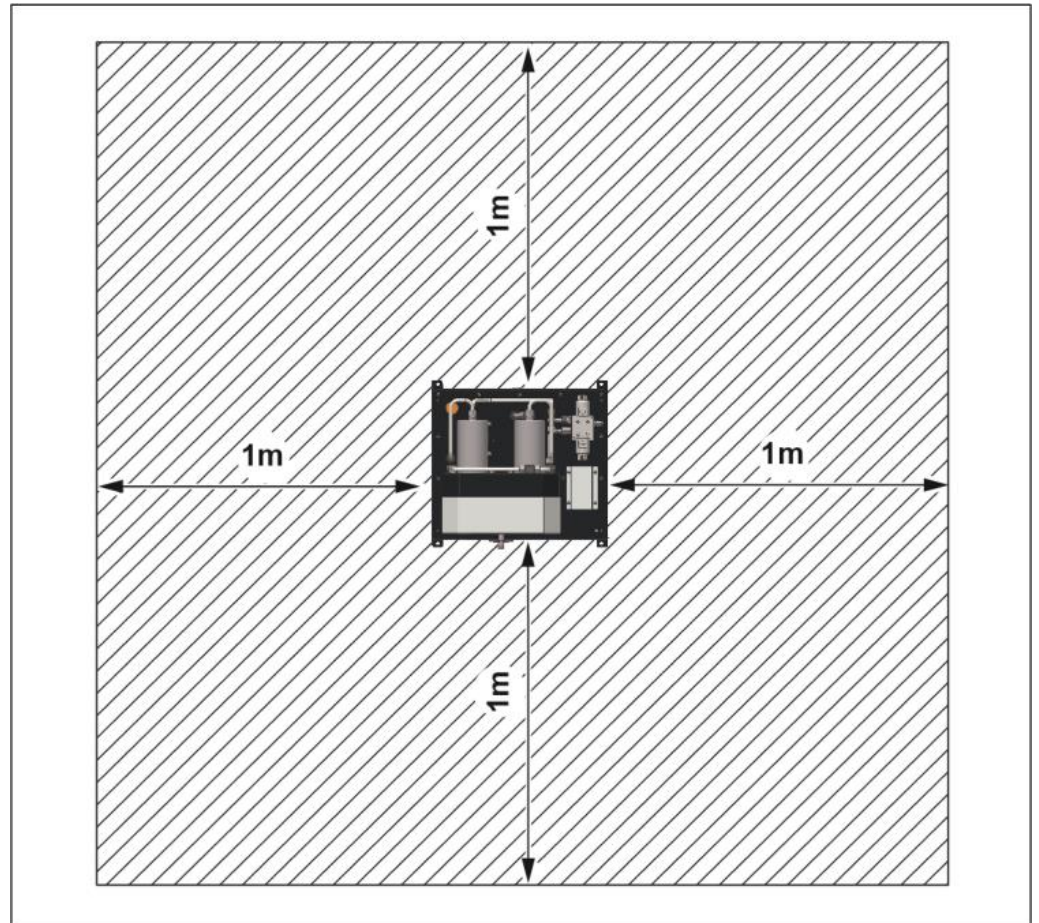

The working area is defined as the area 1 metre all around the machine (shaded).

- Keep the working area free from trip hazards
- Use ducts for lines and cables
- Provide good illumination
- Keep access to hydraulic supply free

### 2.4.2 Emergency-Stop

The machine is fitted with an emergency-stop switch on the control panel.

## 2 Safety instructions

### 2.4 Safety

---

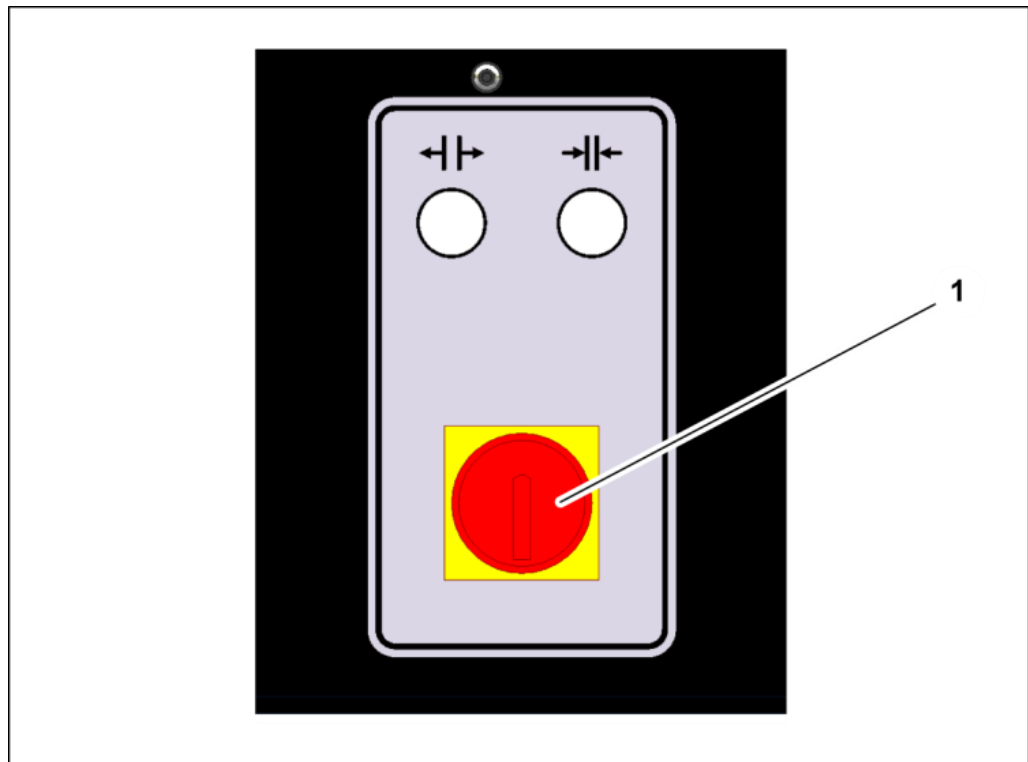

Immediately activate the emergency-stop switch (1) in cases of emergency.

Remedy the cause of the emergency stop first before re-starting the machine.

#### 2.4.3 Protection equipment

Due to the variety of customer-specific workpieces, UNIFLEX is not capable of supplying additional standard protection equipment together with the machine for the prevention of potential residual risks imposed by the machine.

The necessity of additional, workpiece-specific protection equipment may for instance arise for angled workpiece geometries needing a large opening for being inserted into the forming machine. The pressure joining of insulators, structural steel and steel ropes, too, may require special safeguards.

The owner has to consider the need for adapted protection equipment before commissioning. If such need exists, the relevant protection equipment has to be mounted before commissioning of the machine.

## 2 Safety instructions

### 2.4 Safety

UNIFLEX will provide you with customized solutions for protection equipment upon request. Please do not hesitate to address your personal contact for consultation.

Mounted safety equipment must not be removed, bypassed or avoided.

#### 2.4.4 Warning signs on the machine



**Hand injury**  
on the die system



**Risk of squeezing**  
on the die system



**Oiling / greasing prohibited**  
on the die system

Illegible or missing warning signs must immediately be replaced by the operator.



## 2 Safety instructions

### 2.4 Safety

---

## 3 Machine description

### 3.1 Design and function

#### Base machine

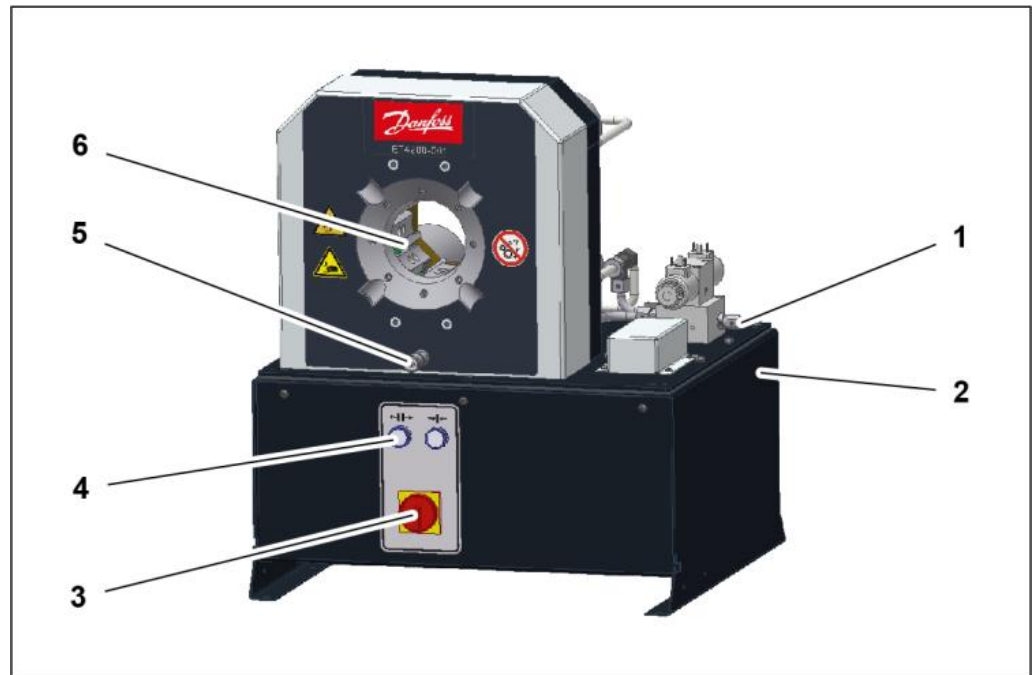

- (1) Manometer connection for pressure test (manometer measuring range: 0 – 400 bar)
- (2) Hydraulic tank (with electric motor, pump)
- (3) Main switch/emergency-stop button
- (4) Control panel
- (5) Micrometer
- (6) Crimping tool

The crimping tool (6) is closed hydraulically, whereby the work piece is formed. The pressure needed for this purpose is generated in the cylinders by the pump driven by the power unit.

The actual forming process is controlled via the buttons on the control panel (4).

The micrometer (5) is used to change the final diameter of the die system.

## 3 Machine description

### 3.2 Accessories

---

#### Crimping tool

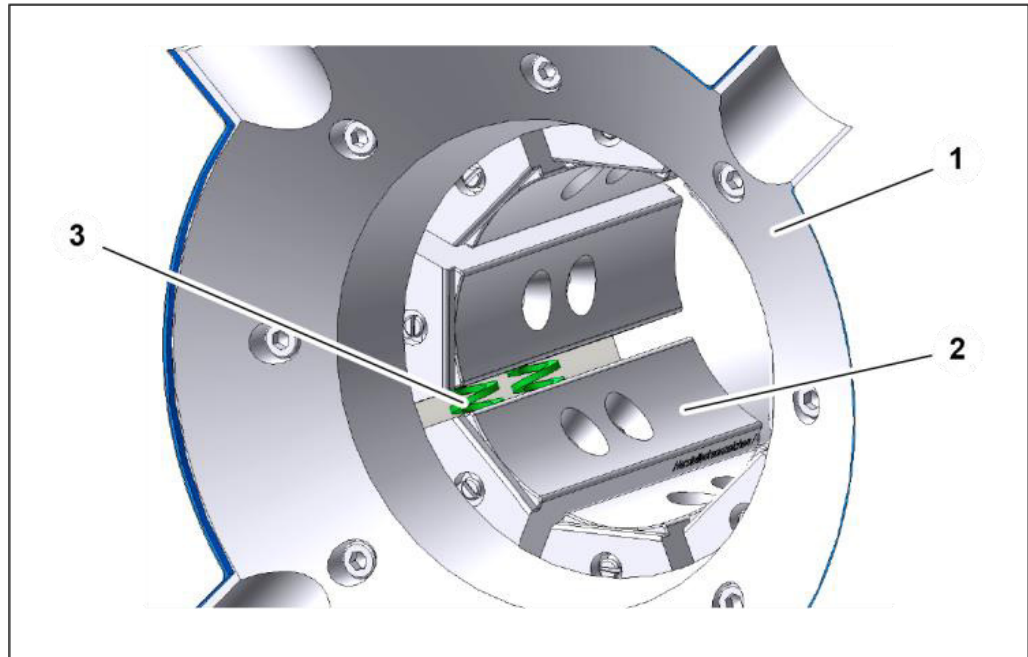

The die system comprises base dies, intermediate dies (depending on the application) and crimping dies.

All base dies are mounted on slide plates. The crimping dies and the intermediate dies, if present, are attached to the base dies (2). The intermediate dies are required if small work pieces are to be formed on a large machine.

After the forming process, the base dies are pressed apart by the pressure springs (3) when the tool opens. The bearing segments (1) on the front guide the base dies axially in the tool.

#### Accessories

The machine can be fitted with accessories. A list of the available accessories is included in the Annex, Section "Accessories".

## 3.2 Accessories

The machine may be fitted with accessories. A list of the available accessories is included in the Annex, Section "Accessories".

## 3.3 Forming process

There is one type of forming:

## 3 Machine description

### 3.3 Forming process

---

- Forming to a defined diameter

#### Forming to a defined diameter

This is the standard process for forming to produce hydraulic hoses. The crimping tool closes until it reaches a pre-set diameter, regardless of the required forming force. The required forming force may be up to the machine's maximum capacity.

#### WARNING!



##### Risk of injuries!

In particular non-metal workpieces may be overstressed by the forming process so that this may result in a sudden failure. Chips or seriously accelerated workpiece parts impose a high risk potential for operators, individuals and objects, even outside the working area!

- Relevant workpieces should only be formed using specific safeguards.

#### ATTENTION!



##### Risk of damage to machinery!

The machine lifetime is reduced with a high permanent load, while wear increases disproportionately. Forming machines for servicing are not intended for permanent operation and are not suitable for series production.

- Do not perform more than 200 **crimping actions** per day.

## 3 Machine description

### 3.4 Operation and display elements

---

#### 3.4 Operation and display elements

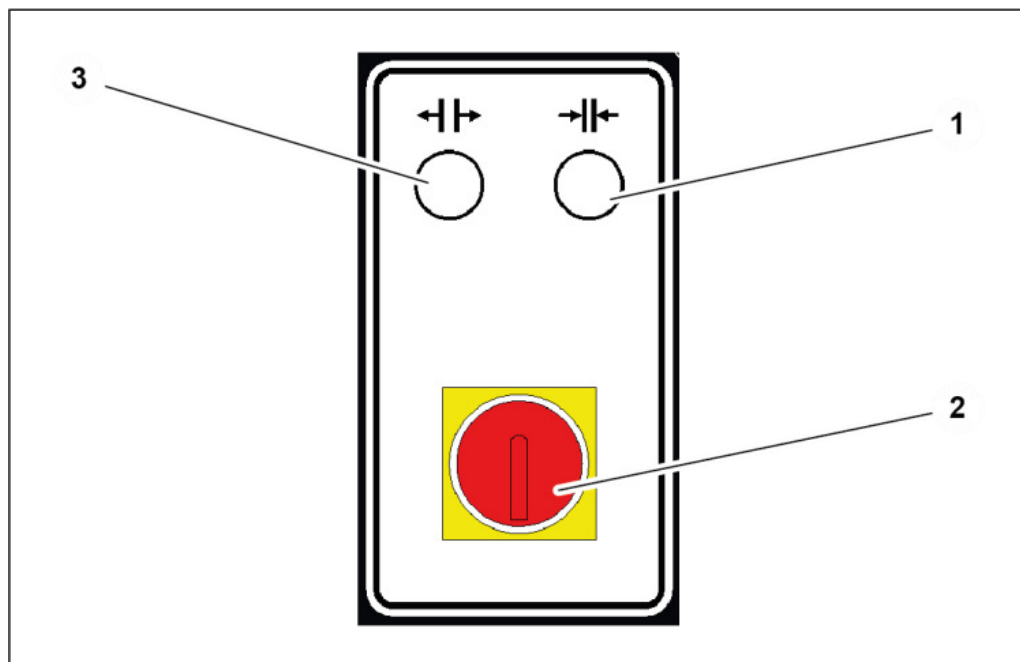

- (1) Close tool button [→|←]
- (2) Main switch / emergency-stop button
- (3) Open tool button [←|→]

#### 3.5 Depth stop (accessory)

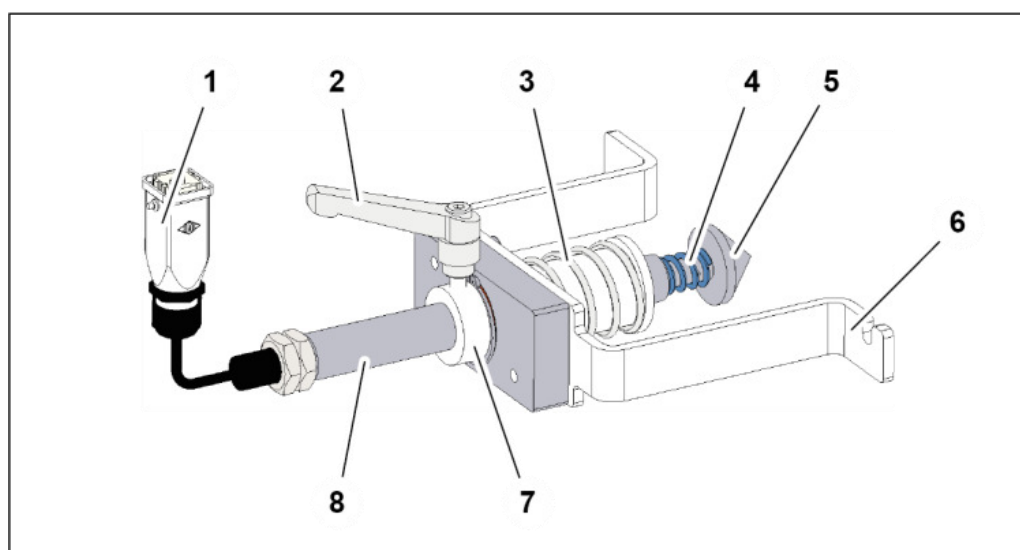

- (1) Connection cable with plunger switch
- (2) Clamp lever

### 3 Machine description

#### 3.5 Depth stop (accessory)

---

- (3) Compression spring
- (4) Compression spring
- (5) Stop cone
- (6) Clamp
- (7) Bushing
- (8) Plunger + sleeve

## 3 Machine description

### 3.6 Technical data

---

#### 3.6 Technical data

##### Machine

|                      |                    |
|----------------------|--------------------|
| Dimensions L x W x H | 592 x 545 x 672 mm |
| Weight               | approx. 150 kg     |
| Control              | CONTROL A          |
| Operation mode       | S3-30%             |
| Noise level          | < 70 dB(A)*        |
| Protection class     | IP 40              |

##### Function

|                           |   |
|---------------------------|---|
| Forming force             | 1200 kN / 120 t   |
| Max. forming range        | Ø crimping dies + 12 mm<br>(max. outside diameter of the fittings before the forming process) |
| Maximum Ø crimping dies   | 62 mm   |
| Opening size without dies | 105 mm  |
| Opening distance          | +35 mm  |
| Closing speed             | 3,23 mm/s*  |
| Forming speed             | 3,23 mm/s*  |
| Opening speed             | 5,37 mm/s*  |

## 3 Machine description

### 3.6 Technical data

---

#### Electrical connection

|   |  |
|---|--|
| Voltage rating                                    | See "Voltage code" in Section 1  |
| Power rating                                      | 3 kW   |
| Back-up fuse                                      | 16 A delayed,<br>preferably thermal fuses, if circuit<br>breakers are used these should be<br>of the class C type. |
| Short circuit current $I_{k3p}$                   | 6,7 kA   |
| Short circuit current $I_{p3p}$                   | 9,7 kA   |
| Full load current of circuit                      | 13,7 A   |
| Full load current of<br>control circuit (primary) | 0,48 A   |

#### Hydraulic system

|  |   |
|--|---|
| Oil volume   | approx. 35 l  |
| Oil type   | HM 46 or HLP 46, ISO 11158 / ISO<br>6743-4, 10 $\mu$ filtered   |
| The oil type can be adapted for<br>specific applications | Viscosity class 68 mm <sup>2</sup> /s for high-<br>temperature operating conditions.<br><br>Viscosity class 32 mm <sup>2</sup> /s for low-<br>temperature operating conditions. |
| System pressure  | max. 350 bar  |

#### Workbench

|  |                |
|--|----------------|
| Stable, level workbench with a<br>carrying capacity of | approx. 500 kg |
|--|----------------|

#### We recommend industrial flooring which meets the following structural requirements

|                         |                                 |
|-------------------------|---------------------------------|
| Permanent floor loading | Approx. 0.07 kg/mm <sup>2</sup> |
| Floor carrying capacity | Min. 2500 kg/m <sup>2</sup>     |



## 3 Machine description

### 3.6 Technical data

---

|               |                        |
|---------------|------------------------|
| Floor quality | B25                    |
| Evenness      | Max. unevenness 5 mm/m |
| Inclination   | max. 5 mm/m            |

#### **Ambient conditions**

|                     |               |
|---------------------|---------------|
| Ambient temperature | 10 °C – 35 °C |
| Air humidity        | 45 % – 65 %   |

The \* data are theoretical/computed values, or values measured on a prototype. Actual values may vary slightly, depending on the machine.

#### **Work piece capacity**

|                               |                                  |
|-------------------------------|----------------------------------|
| SAE R12 / 4SP 1 Part fittings | 1 1/2", depending on the fitting |
| SAE R15 / 4SH 2 Part fittings | 1", depending on the fitting     |
| SAE R12 / 4SP 2 Part fittings | 1 1/4", depending on the fitting |
| Industry                      | 2"                               |
| 90° bend                      | 1 1/2", depending on the fitting |
| Die type                      | 239-xx-Ø                         |

## 4 Transport and commissioning

### 4.1 Transport

The goods should be transported in the original packaging. During transport, the goods must be secured safely within the packaging. All applicable laws and regulations relating to securing loads shall be observed during transport.

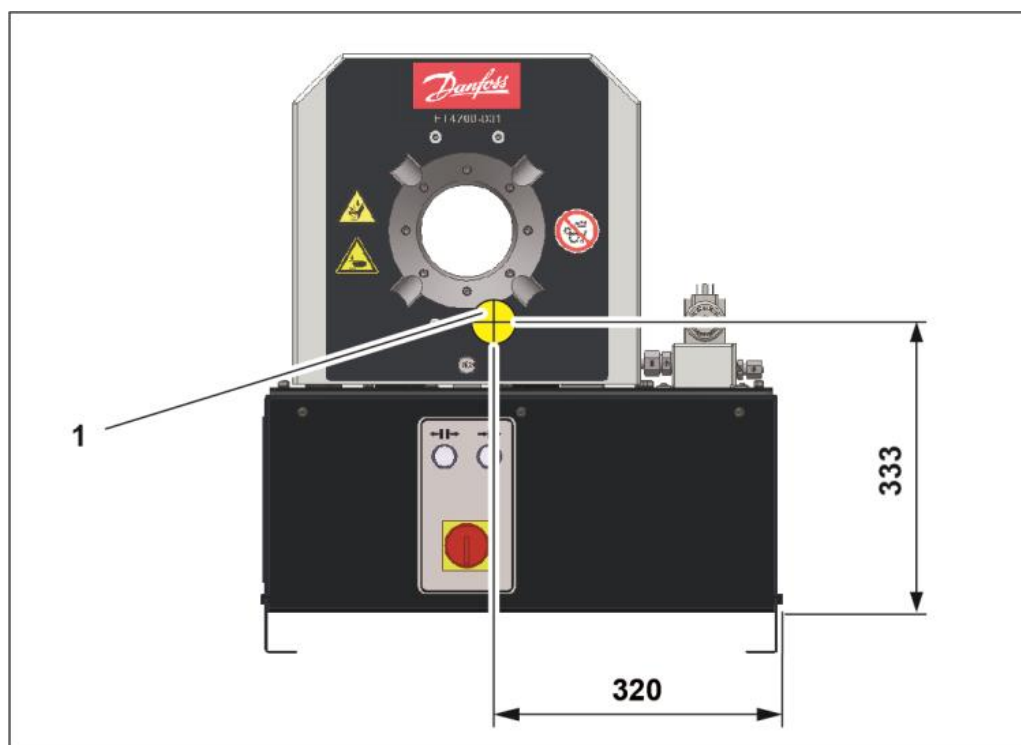

The machine must only be unloaded and transported with a crane. Lifting gear with a sufficient length, width and lifting capacity must be used. For machine weight, please refer to "Technical data" in Section 3.

#### WARNING!



#### Danger from falling loads!

Risk of injury from falling loads.

- Do not stand under suspended loads.

## 4 Transport and commissioning

### 4.2 Intermediate storage of machine/unit

---

#### WARNING!



#### Danger from tilting machine!

The machine may tilt if it is transported improperly. There is a risk of being injured.

- Consider the machine's centre of gravity (1).
- Lift the machine by the crimping tool.

3. Thread the lifting belt with protective hose or fixed coating pursuant to DIN EN 1492-1 with a width of 120 mm through the crimping tool.



The lifting belt must be placed around the crimping tool in such a manner that it supports with its full width.

4. Use the crane to lift the machine with the lifting gear and transport it to the installation site.

## 4.2 Intermediate storage of machine/unit

If the machine/unit cannot be mounted immediately upon delivery, it must be protected against:

- Contamination,
- Weather influences,
- Mechanical damage.

The machine/unit components may only be stored in closed rooms and under the following conditions:

- temperature between 10°C and 35°C,
- maximum air humidity 80% (non-condensating).

## 4.3 Commissioning

The machine is commissioned by the customer's fitter.

1. Place the machine on a stable and level workbench.
2. Bolt the machine onto the workbench.

## 4 Transport and commissioning

### 4.3 Commissioning

---



The workbench must be sufficiently solid and stable.



Place the machine in a way so that it is easily accessible for maintenance work from all sides.

3. Check the machine for damage.
4. Check the electric cables for damage.
5. Train the operating staff and record training sessions in "Declaration of trained staff", Section 9.

#### **WARNING!**



#### **Risk of injuries!**

Machine components might loosen during transport. Such components might be flung out during to the forming process. There is a risk of being injured.

- Open and close the machine several times without any work-piece.
- Check the machine for atypical noise.

#### 4.3.1 Filling hydraulic oil

If the UNIFLEX forming machine was purchased without filled hydraulic oil, the suitable, new, clean and pre-filtered hydraulic oil has to be filled before commissioning (for oil type, please refer to "Technical data" in Section 3).

## 4 Transport and commissioning

### 4.3 Commissioning

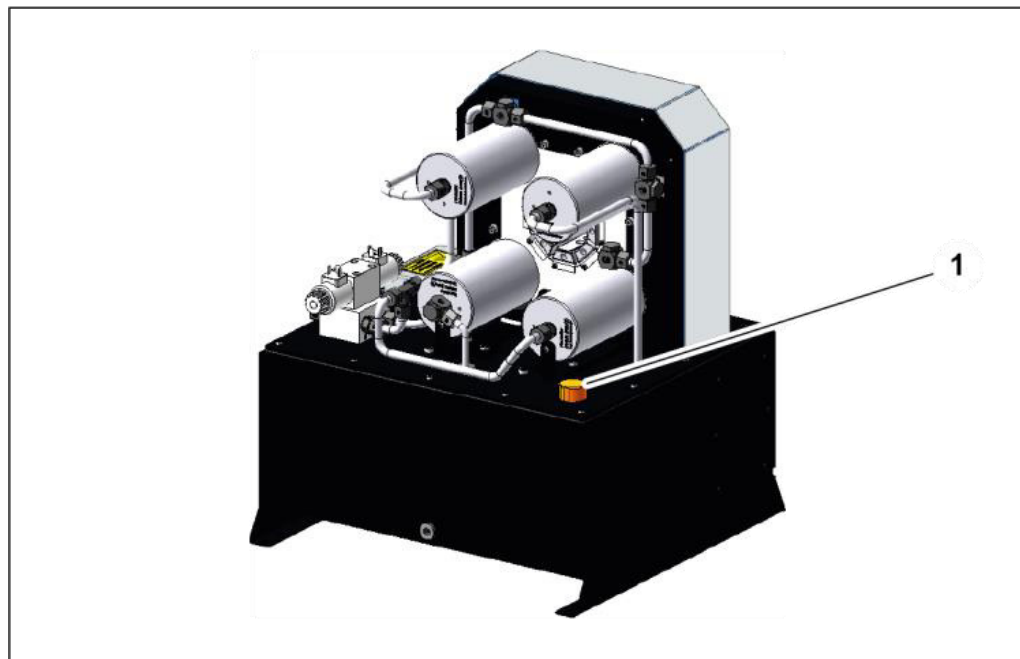

#### CAUTION!



##### **Risk of injuries!**

Contact with hydraulic oil and other consumables imposes a risk of injuries for the skin, eyes, respiratory and intestinal tracts! Hydraulic liquid spills impose a danger of slipping and falling!

- Observe supplier's protection and safety instructions (see data sheet).
- Wear personal protection equipment.
- Do not eat, drink or smoke in the working area and when handling consumables.
- Ensure good ventilation.
- Avoid floor contamination.

#### ATTENTION!



##### **Risk of fire!**

Hydraulic liquid spray or spills impose a risk of fire.

- Avoid ignition sources (welding, cutting and soldering work) near the hydraulic oil filling.

1. Open the air ventilation cap (1).
2. Add hydraulic oil; for quantity and type, please refer to "Technical data" in Section 3. The oil level can be read on the dipstick

## 4 Transport and commissioning

### 4.3 Commissioning

of the air ventilation cap. The oil level should be at the centre of the marking.

3. Close the air ventilation cap (1).
4. Do not operate the machine for a minimum of four hours so that the dirt particles in the system can settle.

#### 4.3.2 Electrical connection

##### WARNING!



##### Danger from electrical voltage!

There is a risk of electrocution near the live parts!

- Work on electric systems may only be performed by qualified electricians or instructed and trained persons under the supervision of a qualified electrician.
- Have the power cable of the machine connected to the local mains by a electrically qualified person according to the regulations of the Electricity Board.
- Do not operate the machine without a sufficiently rated ground wire.
- Before performing maintenance work, switch off the machine and secure it against switching on unintentionally.

1. Disconnect the power supply for the machine and secure it against unintentional restart.
2. Connect the electrical supply cable on the side of the machine to the power supply.



The permissible voltage frequency ranges and the power consumption are also indicated on the name plate.

3. Check the rotation direction of the electric motor (only with three-phase connection) by pressing the open tool button [↔]. If the rotation direction of the electric motor is wrong, the crimping tool does not open at all or only very slowly.

## 4 Transport and commissioning

### 4.3 Commissioning

---

#### ATTENTION!



#### **Risk of damage to machinery!**

Prolonged operation of the motor with an incorrect rotational direction or operating the machine without oil will destroy the hydraulic pump.

- Make sure that the amount of hydraulic oil in the machine is sufficient before starting the machine.

#### 4.3.3 Bleeding the hydraulic system

1. Switch on the machine.
2. Operate the machine in the idle mode for two minutes in order to fill the pump with oil.
3. Open and close the tool several times.
4. Check oil level, add hydraulic oil if required.

## 5 Operation

### 5.1 What you have to observe

---

## 5 Operation

### 5.1 What you have to observe

The operator has received the Operation Manual from the owner, has read and understood it and will observe it.

#### Before starting and/or re-starting

- Ensure sufficient illumination of the working area of the machine/unit.

#### During operation

- Observe the safety instructions on the machine/unit.
- Make sure that no other persons stay in the working area.
- Use appropriate aids to handle heavy workpiece.
- Each movement of the hand must be observed.
- The control cabinet must be closed securely.
- Eating, drinking and smoking at the workplace is prohibited.
- Wear close-fitting clothes.
- Do not wear watches or jewellery.

### 5.2 Start

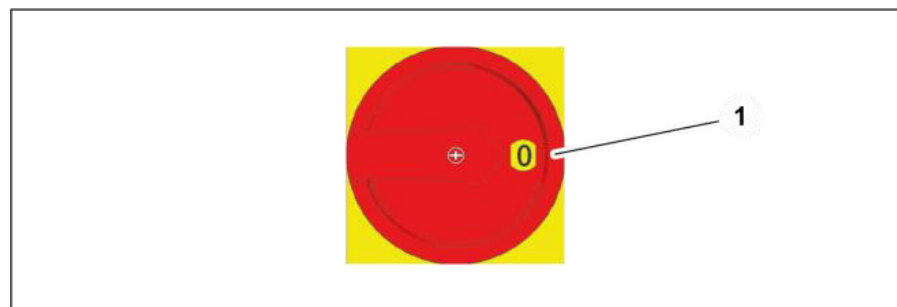

1. Check that there is no emergency-stop situation.
2. Activate the power switch (1).



## 5.3 Forming the workpiece

### 5.3.1 Prerequisites

Prerequisites for a correct forming process:

- The die system and the workpiece are compatible.
- The proper jaw system is correctly mounted in the tool.
- The forming dimension is set correctly, please also refer to “Setting the forming dimension”, Section 5.
- Preferably form the workpiece in the centre of the crimping die length. Eccentric forming will result in a conical forming result and increased lopsided wear on the die system and the bearing plates.

### 5.3.2 Operation mode buttons control panel

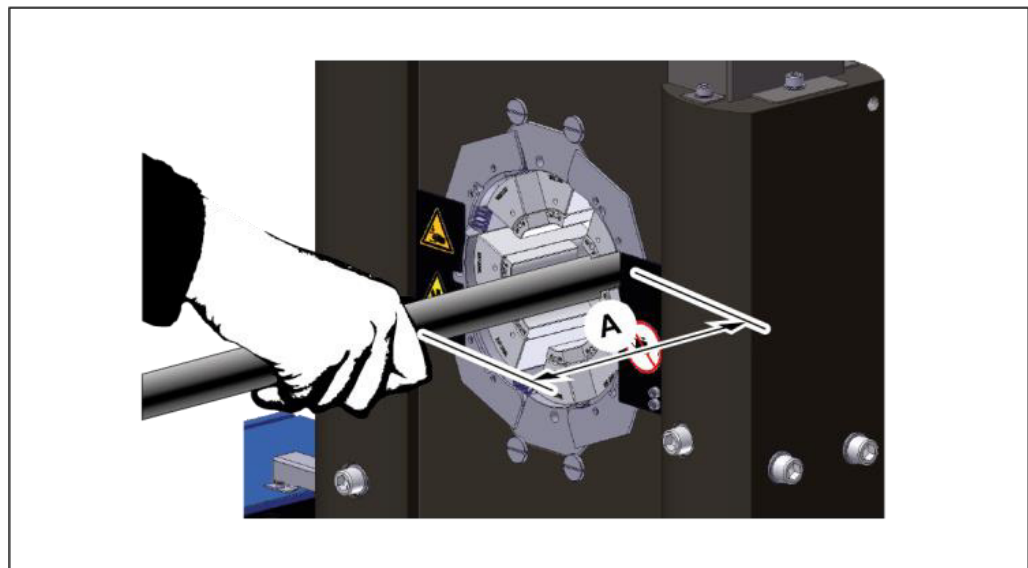

#### WARNING!



#### Risk of squeezing!

When the die system closes, there is a risk of getting squeezed between the die and the workpiece.

- Keep the feed opening for the workpiece as small as possible.
- Keep a minimum distance of 120 mm (A) to the die system.

## 5 Operation

### 5.3 Forming the workpiece

1. Manually position the pre-mounted workpiece in the tool.
2. Hold the workpiece with one hand during the forming process.
3. Press and hold the button [+H+] to close the tool; the forming process starts and ends when the pre-set diameter/pressure is reached.
4. Press the [+H+] button upon completion of the forming process to open the tool.
5. Remove the workpiece from the tool.
6. Check the forming dimension after the first forming process. Correct the forming dimension in case of deviations between the actual dimension and the specified dimension (see "Setting the forming dimension" in Section 5).

#### WARNING!



#### Risk of squeezing!

When the die system closes, there is a risk of getting squeezed between the die and the workpiece.

- Open the crimping tool only so much that the hose may be placed and/or removed easily.

#### 5.3.3 Changing the crimping dies with the quick die change system (only profile 239)

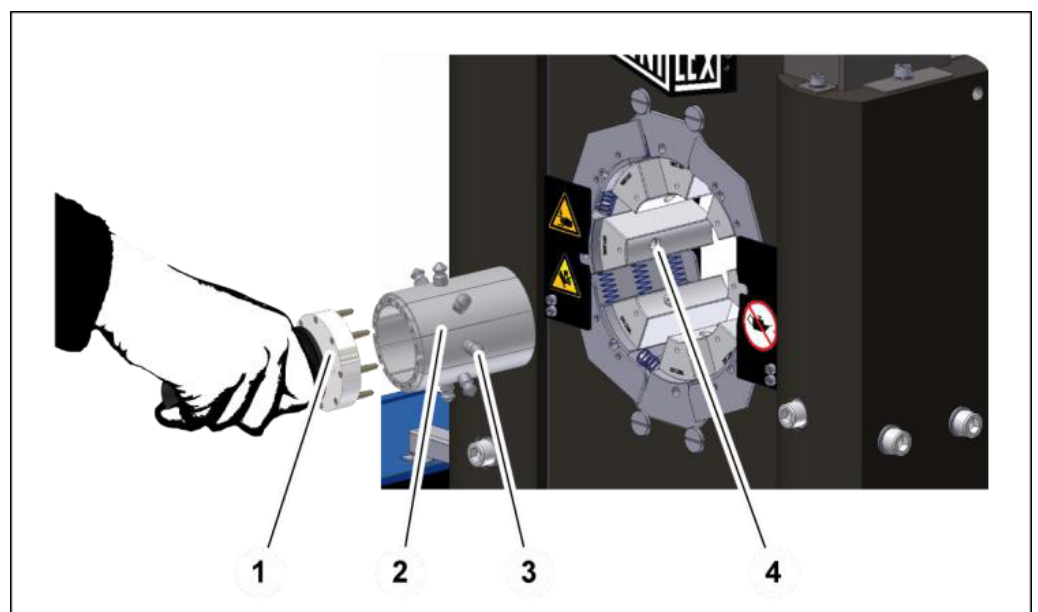

1. Set micrometer to 0.0 mm position.

## 5 Operation

### 5.3 Forming the workpiece

2. Open the crimping tool fully by activating the [↔] button.
3. Push the eight pins of the quick die change system (1) into the front holes of the crimping dies (2).
4. Rotate anti-clockwise and remove the crimping dies (2) from the deposit.
5. Check the retaining bolts (3) of the crimping dies for damage.
6. Hold the quick die change system with crimping dies in the centre of the crimping tool.

#### WARNING!



##### Risk of squeezing!

When the die system closes, there is a risk of getting squeezed between the dies.

- Take care that no parts of your body are inside the forming area when the crimping dies close.

#### ATTENTION!



##### Risk of damage to machinery!

The retaining bolts and the crimping dies will be destroyed if the retaining bolts do not fit in the mounting hole of the base dies or intermediate dies.

- Pay attention to the correct position of the quick die change system with crimping dies.

7. Press the [↔] button to close the tool.  
All retaining bolts (3) must slide into the relevant mounting hole (4) of the basic or intermediate dies, and the spring-mounted pressure pieces must engage into the retaining bolts.
8. Remove the quick die change system (1) and check that the crimping dies fit tightly.
9. Proceed in reverse order to remove the crimping dies.



For machines with a basic die system different from PB 239, the intermediate dies must be inserted as instructed.

## 5 Operation

### 5.3 Forming the workpiece



The QDC 239.5 may only be used to insert or remove the crimping dies of type PB 239.



Always use a complete set of equal crimping dies with the same identification and diameter. One set comprises eight crimping dies or seven crimping dies and one matching marking die.

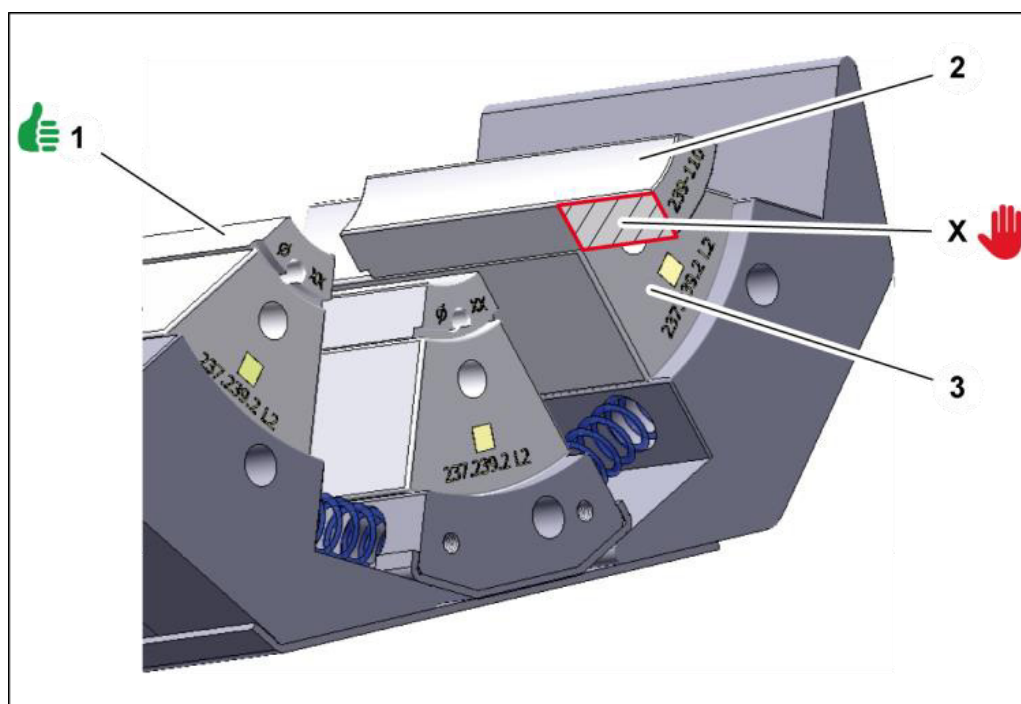

### ATTENTION!



#### Risk of damage to machinery!

If the crimping dies protrude beyond the base and intermediate dies during forming, the crimping dies, the intermediate dies and the machine will be damaged (see (X) in the figure). In the figure, the crimping die (2) is placed incorrectly.

- Place the crimping die (2) in the intermediate die (3) so that it does not protrude.  
In the figure, the crimping die (1) is placed correctly.

## 5 Operation

### 5.4 Adjusting the depth stop

#### 5.4 Adjusting the depth stop

The depth stop must be adjusted specifically for the work piece. When inserting the hose, the crimping process is triggered by contact with the stop cone. When the pre-defined forming diameter or forming pressure is reached, the tool will stop automatically. Remove depth stop for special applications, e.g. pipe bends.

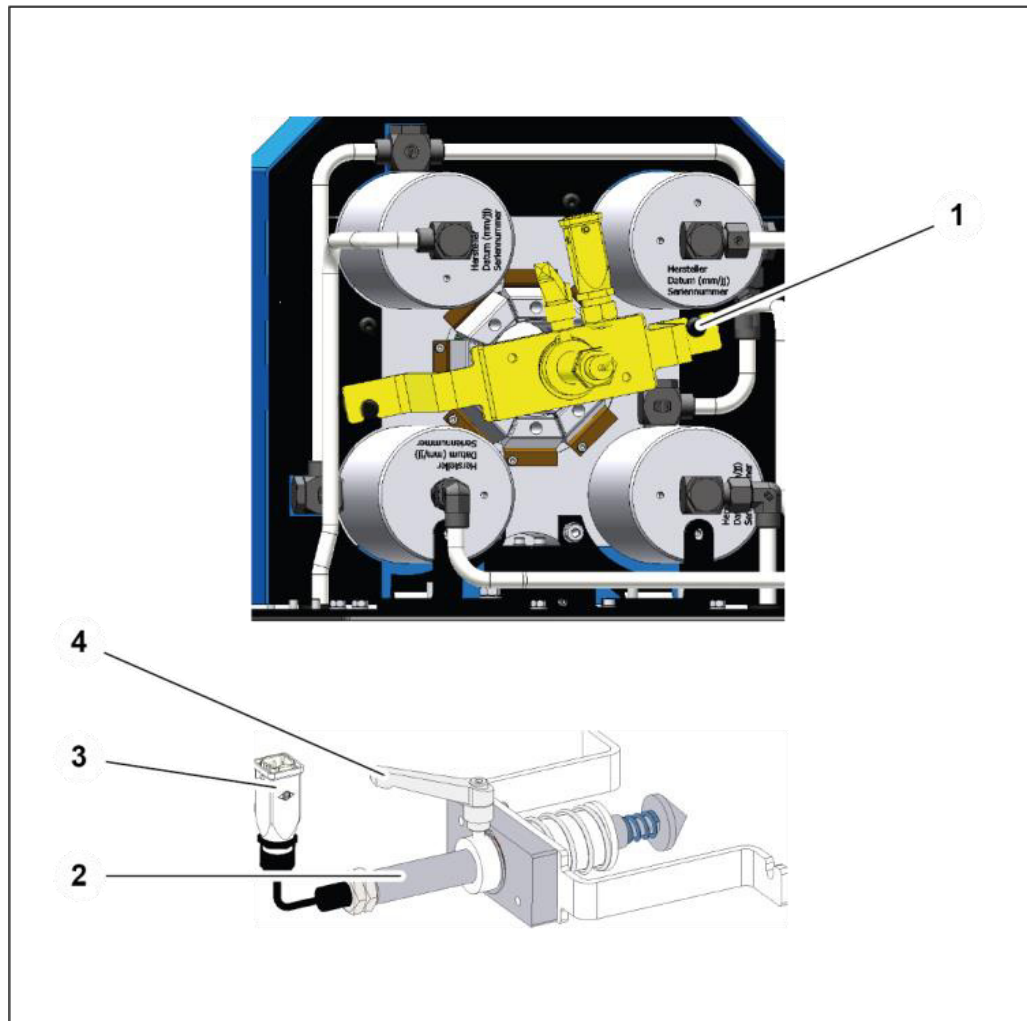

1. Replace the screws (1) by the cylinder bolt, the washer and the circlip.
2. Connect the cable (3) into the socket for the depth stop.

## 5 Operation

### 5.4 Adjusting the depth stop

#### WARNING!



#### Risk of squeezing!

There is risk of getting squeezed between the depth stop and the machine chassis when positioning the depth stop.

- Do not touch the stop cone.
- Do not reach into the open crimping tool.

#### Adjusting the control unit:

1. Insert the fitting in the correct position. Position the fitting within the crimping surfaces and at least 2 - 4 mm away from the end of the crimping die.
2. Press the [↔] button to close the crimping tool until the crimping dies are tight to the crimped sleeve.
3. Disconnect the machine from power supply and secure it against unintentional restart.
4. Loosen the clamping lever (4).
5. Push the sleeve (2) towards the fitting.
6. Tighten the clamping lever (4) securely.
7. Switch on the machine.
8. Activate the illuminated foot pedal . The machine is closed automatically when the workpiece is pressed against the depth stop.
9. Form the work piece.
10. Press the [↔] button to open the tool.
11. Check the work piece.
12. If the work piece meets the requirements: produce other identical work pieces.
13. If the dimension is not reached: Adjust difference on the control unit, form again and check the work piece.



Activate automatic opening in the control for series production.

## 5 Operation

### 5.5 Setting the forming dimension

---

#### 5.5 Setting the forming dimension

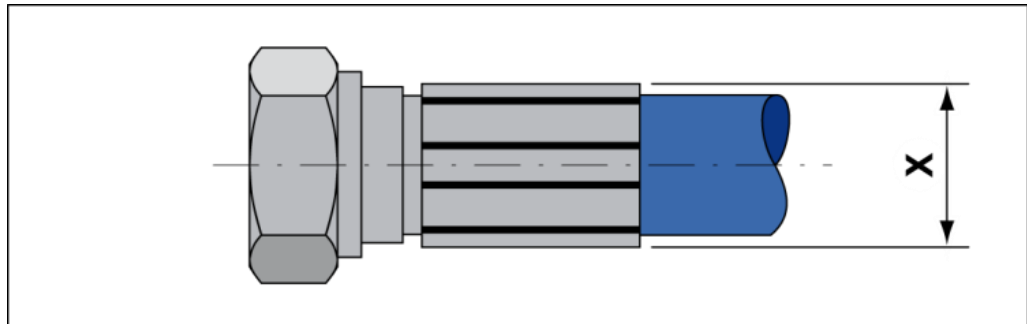

The forming dimension (X) must be set specifically for the workpiece.

1. Read the forming dimension in the forming dimension table of the system supplier, e.g.  $\text{Ø } 17.4 \text{ mm}$ .
2. Select crimping dies with a smaller or the same diameter, e.g.  $\text{Ø } 17 \text{ mm}$ ,
3. Place the crimping dies in the tool.
4. Set the control and/or micrometer to the requested dimension:  
**Control system:** Forming dimension diameter  
**Micrometer:** Workpiece forming dimension less crimping die diameter
5. Form the workpiece.
6. Check the workpiece.
7. If the dimension is reached: manufacture other identical workpieces.
8. If the dimension is not reached: Adjust difference on control and/or in the micrometer, repeat the forming process and check the workpiece.

#### 5.6 Forming travel limitation

If the forming process is started outside the maximum forming range, see “Technical data” in Section 3, the forming distance limitation is activated and the machine stops, depending on the equipment. With machines without any forming distance limitation, tools components may be damaged if the forming range is exceeded.

## 5.7 Stop

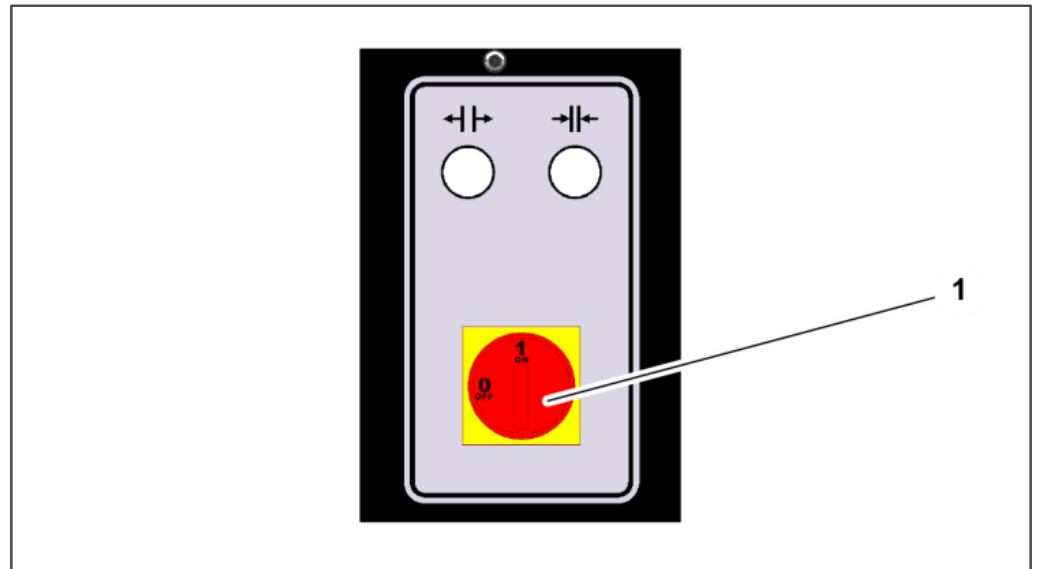

1. Complete the forming process.
2. Deposit the work piece outside the machine.
3. Deactivate the main switch (1).
4. Check the machine for contamination, leaks and external damage.
5. Check the crimping tool and retaining bolts for contamination, damage and secure fitting.
6. Check the oil level.
7. Remove contamination, dust and chips using a vacuum.



Inform the fitter in case of damage or other irregularities.



## 5.8 Emergency stop

### In case of an emergency

Immediately deactivate the emergency-stop switch in cases of emergency. The crimping tool movement will be stopped. The drive unit is shut down.

### Restart after an emergency

#### WARNING!



#### Risk of injuries!

The emergency-stop button was probably activated due to the occurrence of a hazardous situation. A restart of the machine may cause injuries if the hazardous situation has not yet been remedied!

- Remedy the hazardous situation before a restart.

1. Remedy the cause of the emergency stop.
2. Activate the emergency-stop switch.

## 5.9 Cleaning

#### ATTENTION!



#### Risk of damage to machinery!

If the machine is cleaned with a steam jet or compressed air, dirt and water may ingress in the machine and cause serious damage.

- Do not use a steam jet to clean the machine.
- Do not use compressed air to clean the machine.

1. Vacuum the machine from metal abrasion (crimping scale) in the opened crimping tool, or use a soft cloth to clean it. For

## 5 Operation

### 5.9 Cleaning

---

this purpose, remove the crimping dies and the intermediate dies.

## 6 Maintenance

### 6.1 What you have to observe

---

## 6 Maintenance

Regular maintenance will ensure the continuous operation reliability of the device.

### 6.1 What you have to observe

This Section describes action to be taken by you as the fitter regularly to ensure the troublefree use of the machine/unit.

- Maintenance work may only be performed by qualified maintenance staff (machine/unit fitters).
- Repair work on the machine/unit or components may only be performed by appropriately qualified expert staff or UNIFLEX experts!
- The machine/unit must always be deactivated during maintenance work (see "Deactivation" in Section 5). Use the lock to prevent the main switch from being switched on and also attach a sign. Example text:

Machine/unit out of service for  
maintenance work!  
Do not switch on!

- Welding, flame-cutting and grinding work on and in the machine/unit and its environment must be approved in advance. There is a risk of fire. The machine/unit must be cleaned from dust and inflammable substances. Adequate ventilation must be ensured.

### 6.2 Maintenance schedule

If not specified otherwise, inspections listed in the maintenance schedule are visual inspection. Replace defective parts.

If you work in 2 shifts, the check frequency has to be doubled. If you work in 3 shifts, you proceed as with 2-shift operation.

Record maintenance work performed in the maintenance log.

## 6 Maintenance

### 6.2 Maintenance schedule

| Maintenance item  | Weekly | Monthly | Every 6 months | Number of years |
|---|--------|---------|----------------|-----------------|
| <b>Hydraulic system</b>   |        |         |                |                 |
| Hydraulic energy lines – hoses: Check for porosity and leaks.   |        | X       |                |                 |
| Hydraulic energy lines - bolted connections of hoses and pipes: Check for leaks.  |        | X       |                |                 |
| Hydraulic oil: Check oil level, add oil if required (see "Replacing hydraulic oil" in Section 6).   |        | X       |                |                 |
| Hydraulic oil: Replace  |        |         |                | 1               |
| Hydraulic hoses: Have replaced (DIN 20066) no later than six years after manufacture (see label). Make sure that replacement hoses are of equivalent quality (high-pressure hoses). |        |         |                | 6               |
| <b>Crimping tool</b>  |        |         |                |                 |
| Crimping tool: Check for damage and wear.   |        | X       |                |                 |
| Retaining bolt: Check for damage.   |        | X       |                |                 |
| Slide bearing plates: Check for wear (see "Checking and replacing slide bearing plates" in Section 6).  |        |         | X              |                 |
| Pressure springs between base dies: Check for damage.   |        |         | X              |                 |
| Check all bolted connections for secure fitting and retighten if necessary.   |        |         |                | 1               |
| <b>Safety equipment</b>   |        |         |                |                 |
| Emergency-stop button/Emergency stop device: Check function   | X      |         |                |                 |
| Fixed guards and covers: Check for completeness and correct installation.   |        | X       |                |                 |
| For machines with foot switch, only<br>Check case foot switch for completeness. The case protects the pedals against unintentional activation.                                      |        | X       |                |                 |
| Warning signs on the machine: Check legibility (see "Warning signs on the machine" in Section 2).   |        |         | X              |                 |

## 6 Maintenance

### 6.3 Hydraulic oil change

---



Hydraulic oil changes and wear part replacements must be recorded in the maintenance log!

### 6.3 Hydraulic oil change

#### CAUTION!



##### **Risk of injuries!**

Contact with hydraulic oil and other consumables imposes a risk of injuries for the skin, eyes, respiratory and intestinal tracts! Hydraulic liquid spills impose danger of slipping and falling!

- Observe supplier's protection and safety instructions (see data sheet).
- Wear personal protection equipment.
- Do not eat, drink or smoke in the working area and when handling consumables.
- Ensure good ventilation.
- Avoid floor contamination.

#### ATTENTION!



##### **Risk of fire!**

Hydraulic liquid spray or spills imposes a risk of fire.

- Avoid ignition sources (welding, cutting and soldering work) near the hydraulic oil filling.

## 6 Maintenance

### 6.3 Hydraulic oil change

---

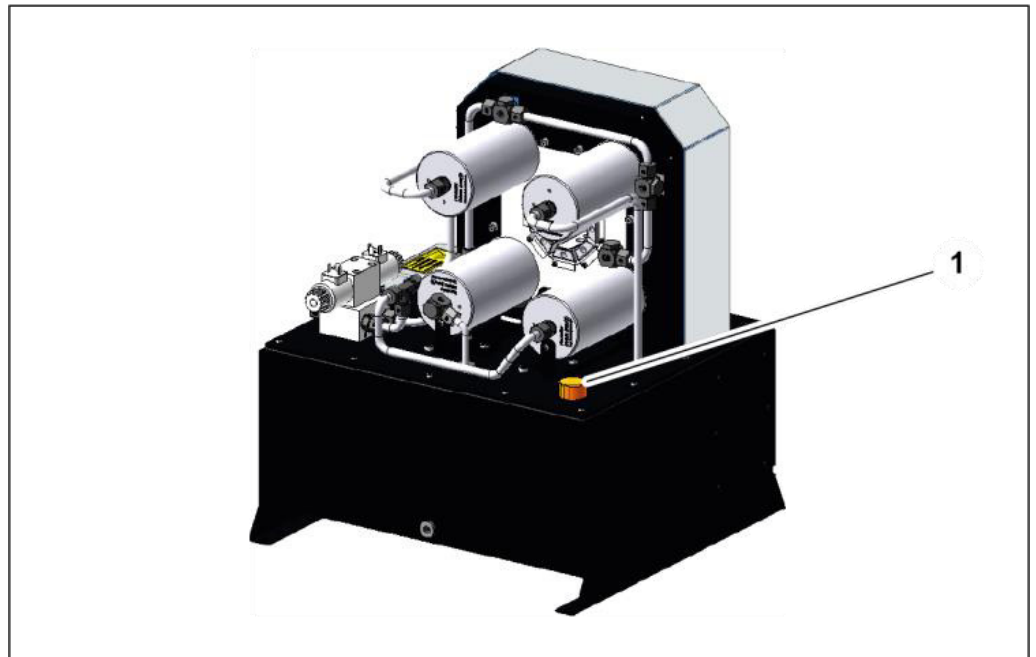

1. Disconnect machine from power supply and secure it against switching on unintentionally.
2. Let the hydraulic oil cool down until the tank enclosure is warm to the touch.
3. Open the air ventilation cap (1).
4. Pump out hydraulic oil using an external pump.
5. Add new hydraulic oil (see “Technical Data” in Section 3).
6. Close the air ventilation cap (1).
7. Do not operate the machine for a minimum of four hours so that the dirt particles in the system can settle.
8. Switch on the machine.
9. Operate the machine in the idle mode for two minutes.
10. Run the tool several times to bleed the hydraulic oil system.
11. Check oil level. The oil level can be read on the dipstick of the air ventilation cap. The oil level should be in the middle of the marking. Add hydraulic oil if necessary.



Dispose of the oil in compliance with the applicable local environmental protection regulations.

## 6 Maintenance

### 6.4 Checking and replacing slide bearing plates

---

#### 6.4 Checking and replacing slide bearing plates

##### Checking slide bearing plates



Check slide bearing plates for wear, replace defective parts. The slide bearing plate (1) is new, the slide bearing plate (2) is worn.

#### **ATTENTION!**



##### **Risk of damage to machinery!**

Worn slide bearing plates may cause damage to the machine and lead to inaccuracies of the forming dimension.

- Replace worn slide bearing plates in good time.

## 6 Maintenance

### 6.4 Checking and replacing slide bearing plates

#### Replacing slide bearing plates

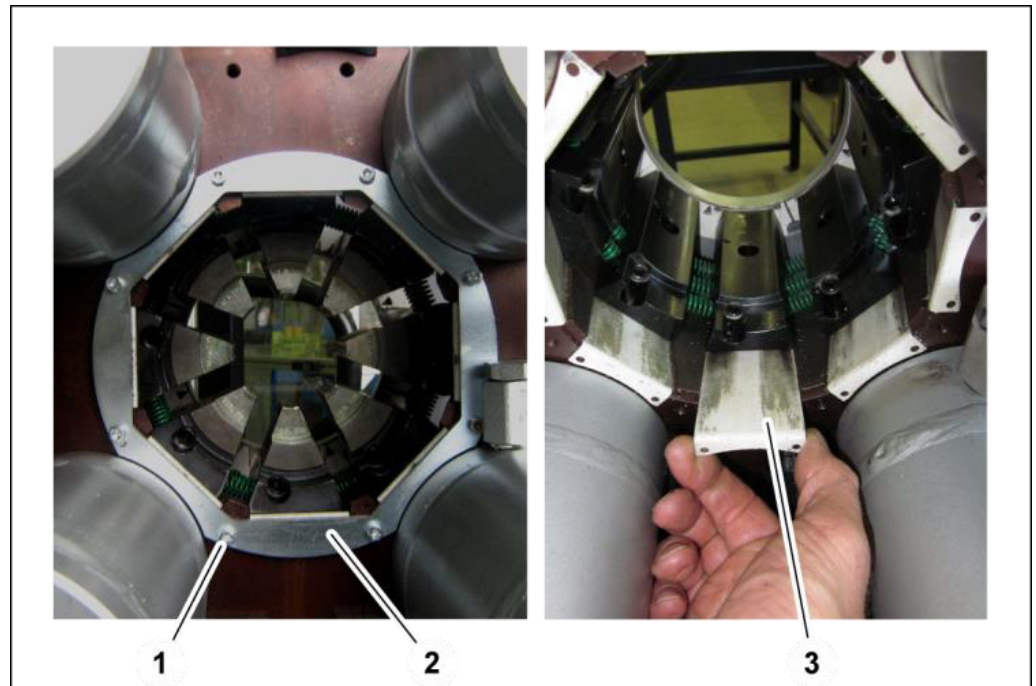

1. Open the crimping tool fully.
2. Deactivate the machine on the main switch and secure it against unintentional restart.
3. Loosen the hexagon socket head screws (1) on the clamping ring (2).
4. Remove clamping ring (2).
5. Pull out old slide bearing plate (3).
6. Insert the new slide bearing plate (3).  
Replace all eight slide bearing plates in this manner.
7. Mount clamping ring (2).
8. Tighten the hexagon socket head screws (1).



Shims, if present, have to be inserted at the same position as before.



Check the machine zero point after each bearing plate replacement and readjust the micrometre if necessary.



## 6 Maintenance

### 6.5 Micrometer adjustment

---

#### 6.5 Micrometer adjustment

If the measured forming dimensions of the workpiece deviate from the forming dimensions of the crimping die when the micrometer is set to zero, the micrometer must be readjusted.

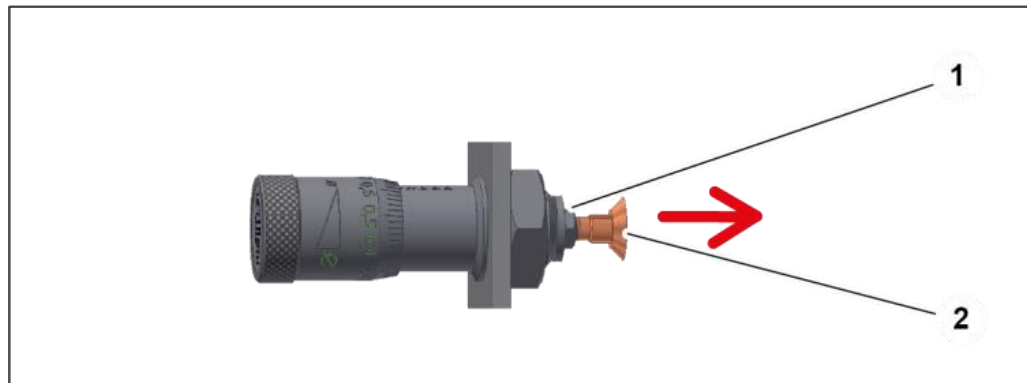

1. Release the screws on the cover.
2. Remove the cover (see “Annex” in Section 9).
3. Loosen the counter-nut (1) of the contact screw (2).
4. Adjust the contact screw (2).



2.5 revolutions of the contact screw correspond to 1 mm change in the forming dimension.

5. Remount the enclosure/front panel.
6. Test the crimping process and readjust if necessary.

## 7 Troubleshooting

| Error                            | Cause  | Remedy  |
|----------------------------------|--|---|
| Machine does not close/open      | Main switch is OFF                               | Switch on the main switch   |
|                                  | Voltage incorrect                                | Check voltage supply  |
|                                  | Power plug defective                             | Check power plug and replace if necessary   |
|                                  | Rotational direction of electric motor incorrect | Check rotation direction, correct electrical connection   |
|                                  | Phase applied to neutral conductor               | Check power plug, correct electrical connection   |
| Machine forms unevenly/conically | Insufficient amount of hydraulic oil             | Refill oil  |
|                                  | Power unit defective                             | Check power unit  |
|                                  | Operation buttons defective                      | Check operation buttons and replace, if required  |
|                                  | Bearing plates worn                              | Check bearing plates for wear and replace if necessary  |
|                                  | Base dies damaged                                | Check base dies for damage and replace if necessary   |
| Crimping dimension not achieved  | Crimping dies damaged                            | Check crimping dies for damage and replace if necessary   |
|                                  | Crimping area not centred                        | Preferably form the work piece in the centre of the crimping die length   |
|                                  | Bearing plates worn                              | Check bearing plates for wear and replace if necessary  |
| Crimping dimension not achieved  | Oil pressure too low                             | Check oil pressure at the MP measuring point, pump or pipe may be leaking or defective, repair or replace   |
|                                  | Incorrect crimping dies used                     | Check crimping die diameter and crimping die section and replace, if required (for crimping die section, please refer to "Technical data" in Section 3) |

## 8 Decommissioning, disposal

### WARNING!



#### Risk by electrical voltage!

There is a risk of electrocution near the live parts!

- Shut down the machine/unit.
- Disconnect the machine/unit from the power supply.

### CAUTION!



#### Risk of injuries!

Contact with hydraulic oil and other consumables imposes a risk of injuries for the skin, eyes, respiratory and intestinal tracts! Hydraulic liquid spills impose danger of slipping and falling!

- Observe supplier's protection and safety instructions (see data sheet).
- Wear personal protection equipment.
- Do not eat, drink or smoke in the working area and when handling consumables.
- Ensure good ventilation.
- Avoid floor contamination.

### ATTENTION!



#### Risk of fire!

Hydraulic liquid spray or spills imposes a risk of fire.

- Avoid ignition sources (welding, cutting and soldering work) near the hydraulic oil filling.

### CAUTION!



#### Risk of injuries!

Parts of the machine/unit may be under pressure and/or tension. Loosening components may impose a risk of injuries!

- De-pressurize the machine/unit before performing any work and check for potential sources of hazard.

## 8 Decommissioning, disposal

### 8.1 Dismantling

---

#### 8.1 Dismantling

This section describes activities to be performed by you as the operator to ensure the safe dismantling of the machine/unit.

- The machine/unit may only be dismantled by entrusted and qualified staff.
- Open the machine/unit completely.
- Depressurise the machine/unit before dismantling it (deactivate the hydraulic pump and secure it against restart; operate valve manually, if any; open bolted hydraulic connections slowly and carefully).
- Check the machine/unit for mechanical tension and consider it during dismantling.
- Empty the machine/unit of all consumables, see "Maintenance", Section 6.

#### 8.2 Recycling

The machine/unit contains metal, hydraulic hoses, electric cables and electronic components, depending on the type.

As regards disposal, the applicable national environmental protection and waste disposal regulations have to be complied with.

#### 8.3 Consumables and waste

Observe applicable national environmental protection and waste disposal regulations.

Return consumables, e.g. oils, greases, test media, to supplier - they are hazardous waste. Also observe the information given on the safety data sheet.

## 9 Annex



Individual machine/unit components may deviate in their features. Please indicate the serial number of the machine for spare part orders.

# 9 Annex

## 9.1 Machine overview

### 9.1 Machine overview

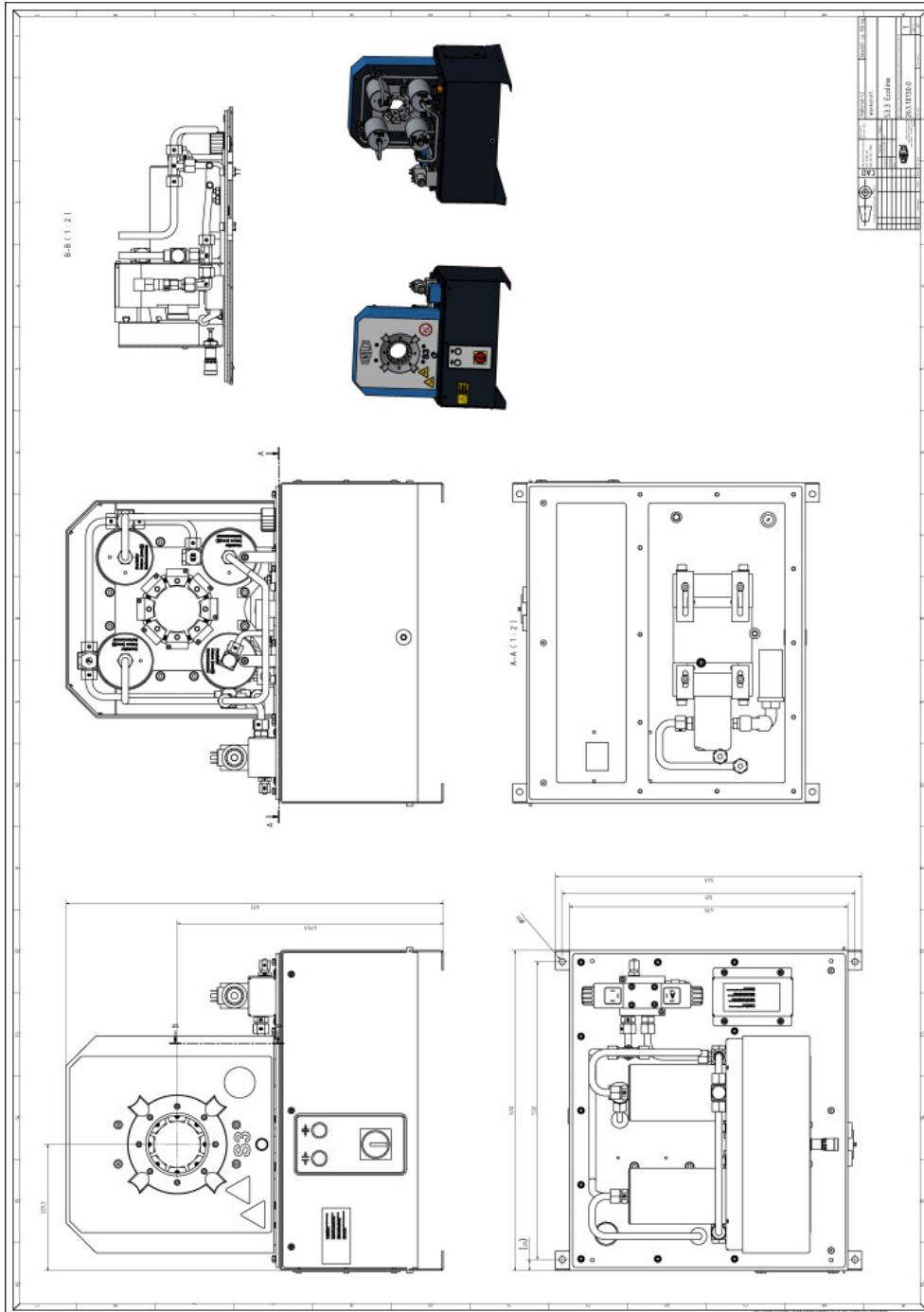

## 9 Annex

### 9.2 Accessories (retrofitable)

---

#### 9.2 Accessories (retrofitable)

| Accessories                        | Part code  |
|------------------------------------|--|
| Quick die change system            | QDC 239.5  |
| Die deposit                        | QDS 239 B<br>QDS 239 C<br>QDS 239 R                |
| TU-QDS crimping die deposit system | TU-QDS F Basic<br>TU-QDS F Shelf<br>TU-QDS F 239 I |
| End stop                           | TA S3.1/4.1  |
| Mirror                             | SHS S3.1   |
| Camera set                         | OCS 10.3 retro                                     |
| Lamp with magnetic base            | LUS  |
| Die wrench                         | 239.017.4  |
| Universal table                    | TU   |
| Crimping dies system               | PB 263   |

Please contact our Sales department for ordering accessories.

## 9.3 Spare parts list

### 9.3.1 Tool

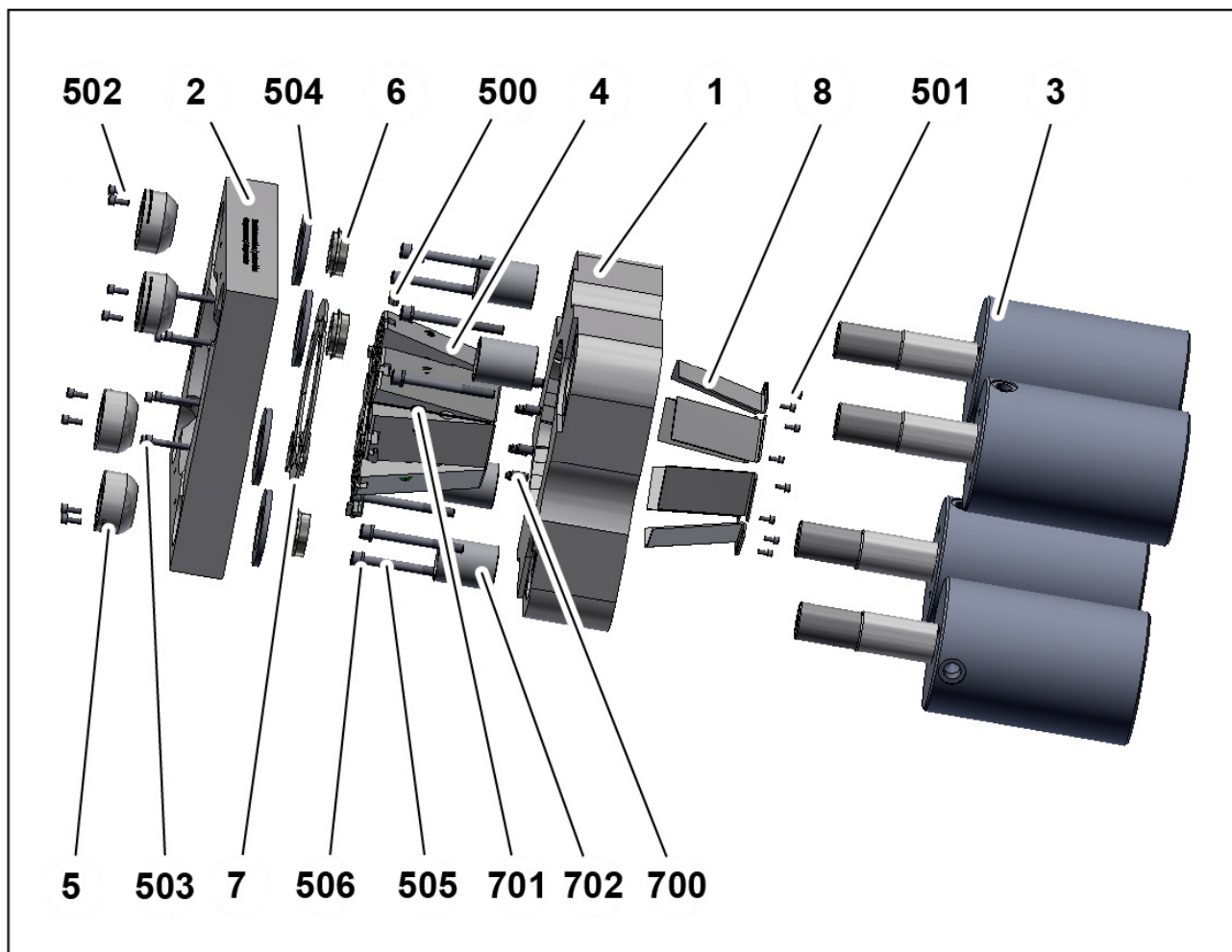

| Item | Quantity | Part code  | Designation                        |
|------|----------|------------|------------------------------------|
| 1    | 1        | 264.191.0  | Pressure plate, back               |
| 2    | 1        | 264.171.0  | Pressure plate, front              |
| 3    | 4        | 263.390.3  | Hydraulic cylinder                 |
| 4    | 1        | 264.2      | Base dies set                      |
| 5    | 4        | 264.194.3  | Ball nut                           |
| 6    | 4        | 264.186.4  | Sleeve                             |
| 7    | 2        | 264.185.3  | Bearing segment                    |
| 8    | 8        | 264.196.4  | Bearing plate, rear pressure plate |
| 500  | 8        | 798.320003 | T-groove nut                       |



## 9 Annex

### 9.3 Spare parts list

| Item | Quantity | Part code  | Designation  |
|------|----------|------------|--|
| 501  | 8        | 798.110088 | Cylinder screw with hexagon socket ISO 4762 – M4x8 - galvanised  |
| 502  | 8        | 798.120068 | Cylinder screw with hexagon socket DIN 4762 – M5x10 - 12.9       |
| 503  | 8        | 798.110103 | Cylinder screw with hexagon socket ISO 4762 – M5x35 - galvanised |
| 504  | 4        | 798.210035 | Washer DIN EN ISO 7089 – 36 galvanised                           |
| 505  | 8        | 798.110127 | Cylinder screw with hexagon socket ISO 4762 – M8x80 - galvanised |
| 506  | 8        | 798.750004 | Spring washer DIN127 – A 8 – galvanised                          |
| 700  | 8        | 239.151    | Pressure spring screw  |
| 701  | 16       | 268.150    | Pressure spring  |
| 702  | 4        | 3550DU     | Bearing bush   |

#### 9.3.2 Mechanical equipment

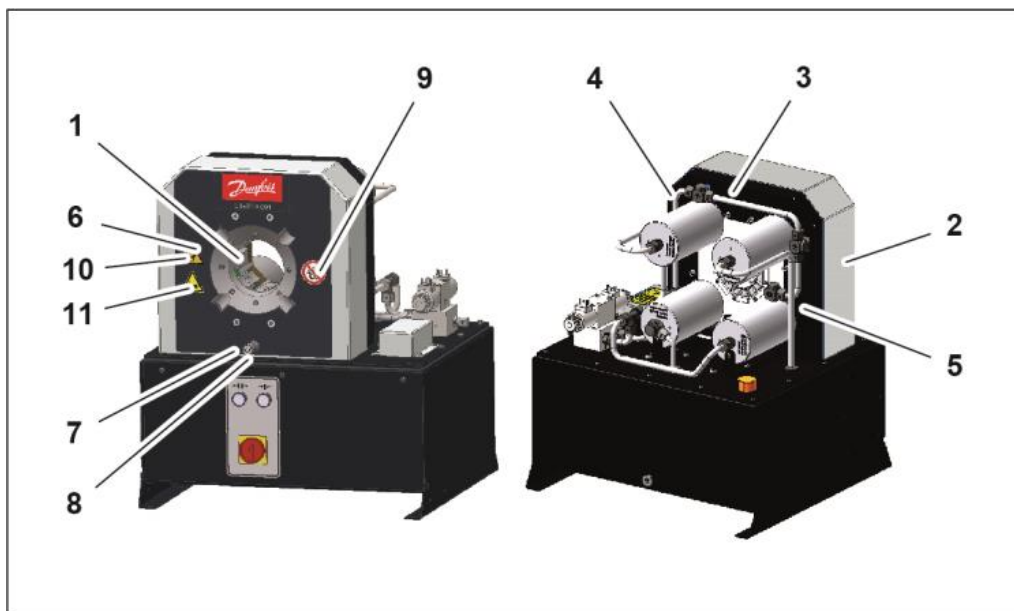

| Item | Quantity | Part code               | Designation           |
|------|----------|-------------------------|-----------------------|
| 1    | 1        | 263.1194                | Crimping tool         |
| 2    | 1        | 263.250.2 + colour code | Cover                 |
| 3    | 1        | 263.255.3               | Protective plate, top |

## 9 Annex

### 9.3 Spare parts list

| Item | Quantity | Part code | Designation                  |
|------|----------|-----------|------------------------------|
| 4    | 1        | 263.256.3 | Protective plate, right side |
| 5    | 1        | 263.257.3 | Protective plate, left side  |
| 6    | 1        | 777.943   | Designation sign             |
| 7    | 1        | 219.400.3 | Crimping micrometer          |
| 8    | 1        | 211.502.3 | Round closing blank Uniflex  |
| 9    | 1        | 578.4     | Oil prohibition sign         |
| 10   | 1        | 715.4     | Squeezing risk warning sign  |
| 11   | 1        | 716.4     | Hand injuries warning sign   |

#### 9.3.3 Hydraulic system

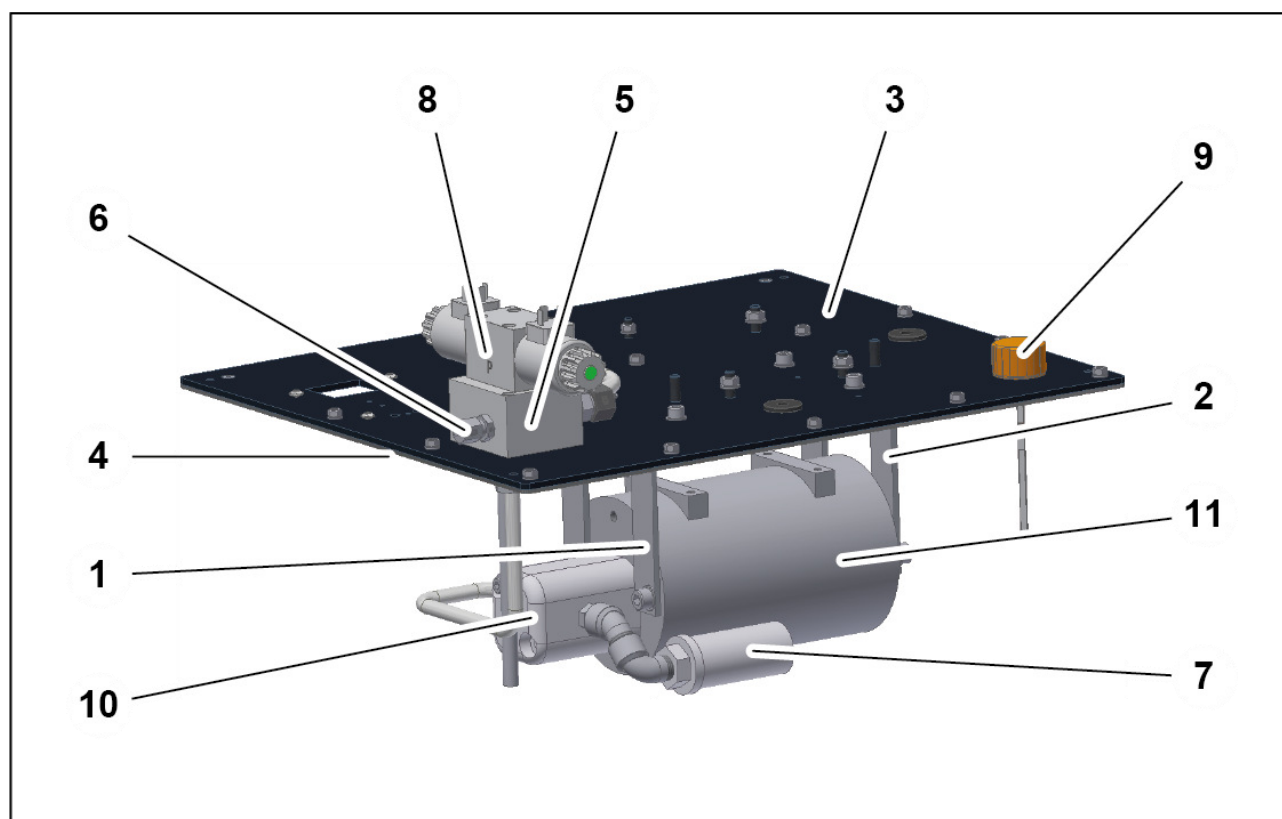

| Item | Quantity | Part code | Designation      |
|------|----------|-----------|------------------|
| 1    | 1 set    | 263.234.3 | Motor attachment |
| 2    | 1 set    | 263.233.3 | Motor attachment |
| 3    | 1        | 264.241.2 | Tank cover       |
| 4    | 1        | 264.324.2 | Tank seal        |

## 9 Annex

### 9.3 Spare parts list

| Item       | Quantity | Part code | Designation                               |
|------------|----------|-----------|---|
| 5          | 1        | 264.320   | Hydraulic block, complete                 |
| 6          | 1        | 235.326   | Hydraulic block pressure limitation valve |
| 7          | 2        | 239.516   | Suction filter ½"                         |
| 8          | 1        | 227.001   | NG 6 directional valve 24 V DC            |
| 9          | 1        | 264.321.3 | Air ventilation cap with oil dipstick     |
| 10         | 1        | 264.351   | Hydraulic pump                            |
| 11         | 1        | 264.101   | Electric engine                           |
| No picture | 1        | 264.319   | Hydraulic kit tank plate                  |

#### 9.3.4 Electric equipment

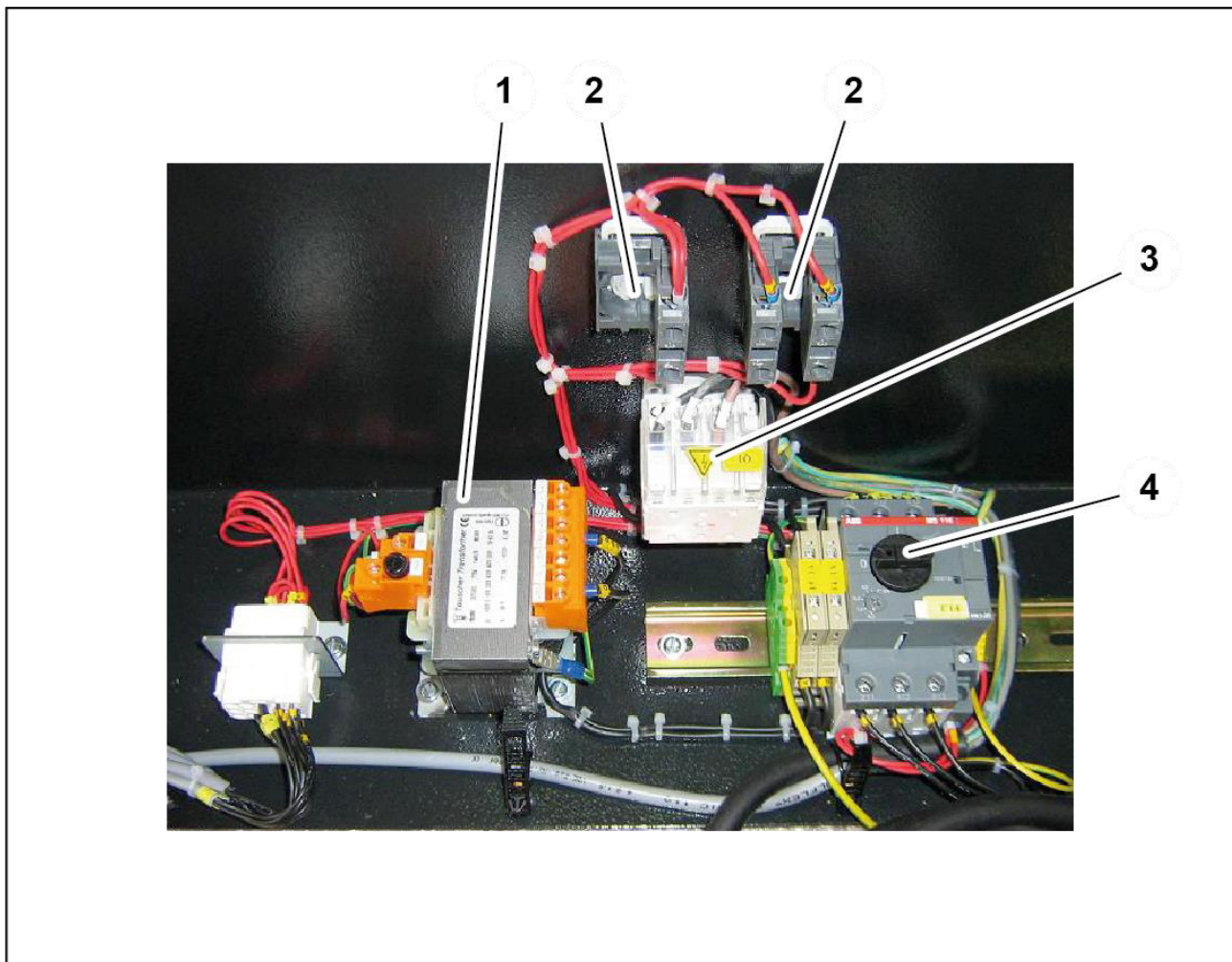

## 9 Annex

### 9.4 Spare parts kit

| Item | Quantity | Part code | Designation                                       |
|------|----------|-----------|---|
| 1    | 1        | 800.021   | Transformer                                       |
| 2    | 2        | 8.06.077  | Pushbutton frame                                  |
|      | 2        | 8.06.078  | Contact block 1 make + 1 break with retainer      |
| 3    | 1        | 800.053   | Main switch                                       |
| 4    | 1        | 8.06.001  | Motor protection switch 6.3 - 10 A_00 / _04 / _40 |
|      |          | 8.06.002  | Motor protection switch 10 - 16 A_20 / _23 / _22  |
|      |          | 8.06.145  | Motor protection switch 16 - 20 A_26              |
|      |          | 8.06.147  | Motor protection switch 25 - 32 A_11              |

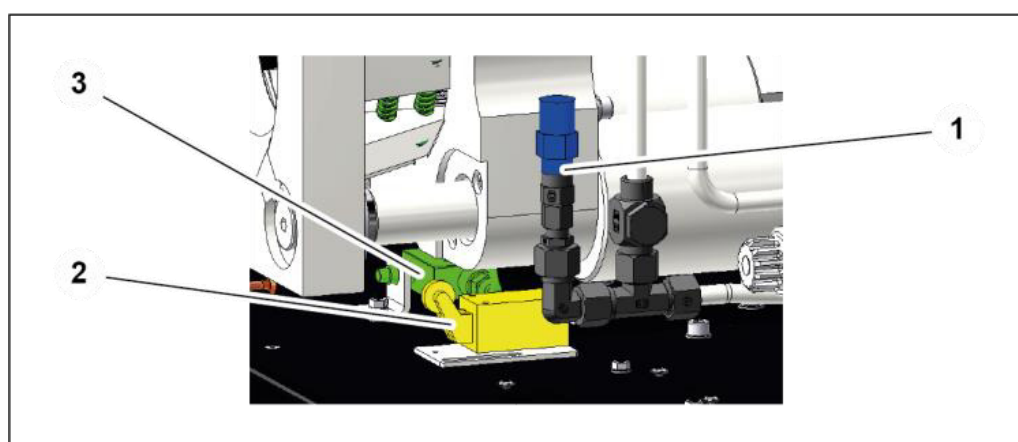

| Item | Quantity | Part code | Designation            |
|------|----------|-----------|------------------------|
| 1    | 1        | 245.515   | Piston pressure switch |
| 2    | 1        | 8.12.041  | Position switch        |
| 3    | 1        | Z-15-GQ3  | Limit switch           |

## 9.4 Spare parts kit

| Quantity  | Part code    | Designation   |
|-----------|--------------|---|
| 1 set     | 263.1        | Spare parts set S3.1/4.1 bearing plates for base dies |
| 1 set     | 263.2        | Spare parts set S3.1/4.1 front bearing segments       |
| 8 per set | 239.041.4 sw | Retaining bolt, plastic (profile: 239 / 239L)         |
| 8 per set | 239.041.4    | Retaining bolt, steel (profile: 239 / 239L)           |
| 8 per set | 239.151      | Pressure piece  |
| 1         | 263.11       | Repair tool set                                       |
| 1         | 263.4        | Spare parts set, set of base dies S3/S4               |
| 1         | 263.5        | Spare parts set, cover S3                             |

## 9 Annex

### 9.5 Service tool

---









### 9.5 Service tool

| Quantity | Part code | Designation   |
|----------|-----------|---|
| 1        | 264.550   | Installation aid, ball nut (item 5)                                 |
| 1        | 264.560   | Installation aid, slide bearing plate (item 7) front pressure plate |

## 9 Annex

### 9.6 Retaining bolt for standard crimping dies (depending on crimping die)

### 9.6 Retaining bolt for standard crimping dies (depending on crimping die)

| Retaining bolt  | Crimping die profile |     |     |     |               |     |     |     |     |     |
|---|----------------------|-----|-----|-----|---------------|-----|-----|-----|-----|-----|
|   | 262                  | 263 | 239 | 266 | 232           | 237 | 554 | 245 | 246 | 247 |
| <br>262.104.4        | x                    |     |     |     |               |     |     |     |     |     |
| <br>262.129.3        |                      | x   |     |     |               |     |     |     |     |     |
| <br>239.041.4       |                      |     | x   |     |               |     |     |     |     |     |
| <br>239.041.4 (sw) |                      |     | x   |     |               |     |     |     |     |     |
| <br>232.504.4      |                      |     |     | x   | x             | x   |     |     |     |     |
| <br>232.505.4      |                      |     |     |     | Ø96 /<br>Ø103 |     |     |     |     |     |
| <br>220.502.4      |                      |     |     |     |               |     | x   |     |     |     |
| <br>245.114.4      |                      |     |     |     |               |     |     | x   | x   | x   |

## 9 Annex

### 9.6 Retaining bolt for standard crimping dies (depending on crimping die)

---





# 9 Annex

## 9.8 Electric diagram

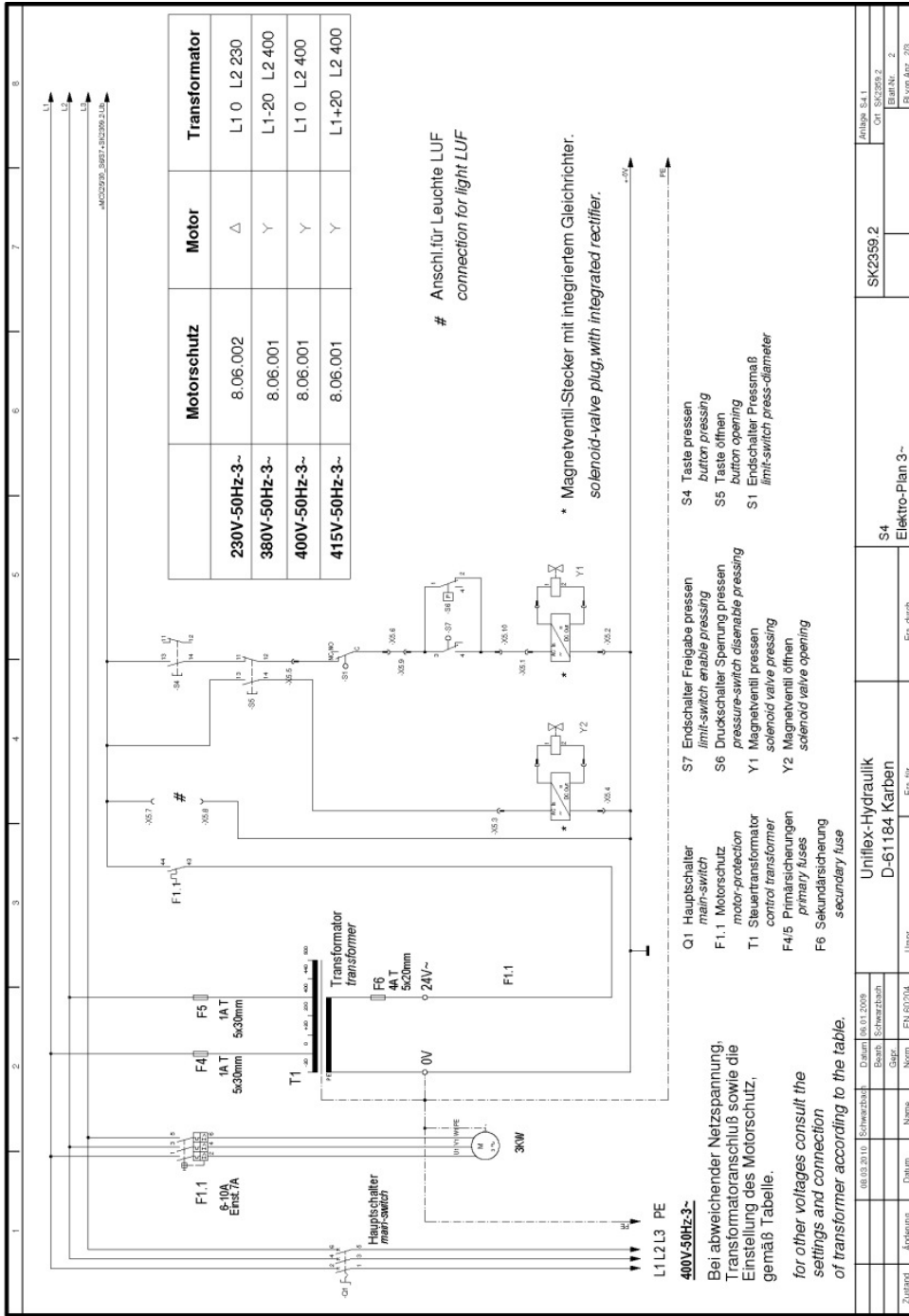

|          |            |                                     |                       |
|----------|------------|-------------------------------------|-----------------------|
| Zustand  |            |                                     |                       |
| Änderung | Datum      | Name                                | Norm                  |
|          | 08.02.2010 | Schweibsch                          | DIN EN 60204          |
|          |            | Bearb: Schwarzbach                  |                       |
|          |            | Gepr: Gier                          |                       |
|          |            | Unger                               |                       |
|          |            | Ein. für                            | Ein. durch            |
|          |            | Uniflex-Hydraulik<br>D-61184 Karben | S4<br>Elektro-Plan 3~ |
|          |            |                                     | SK2359.2              |
|          |            |                                     | Blatt Nr. 2           |
|          |            |                                     | Blatt von Blatt 20    |

# 9 Annex

## 9.8 Electric diagram

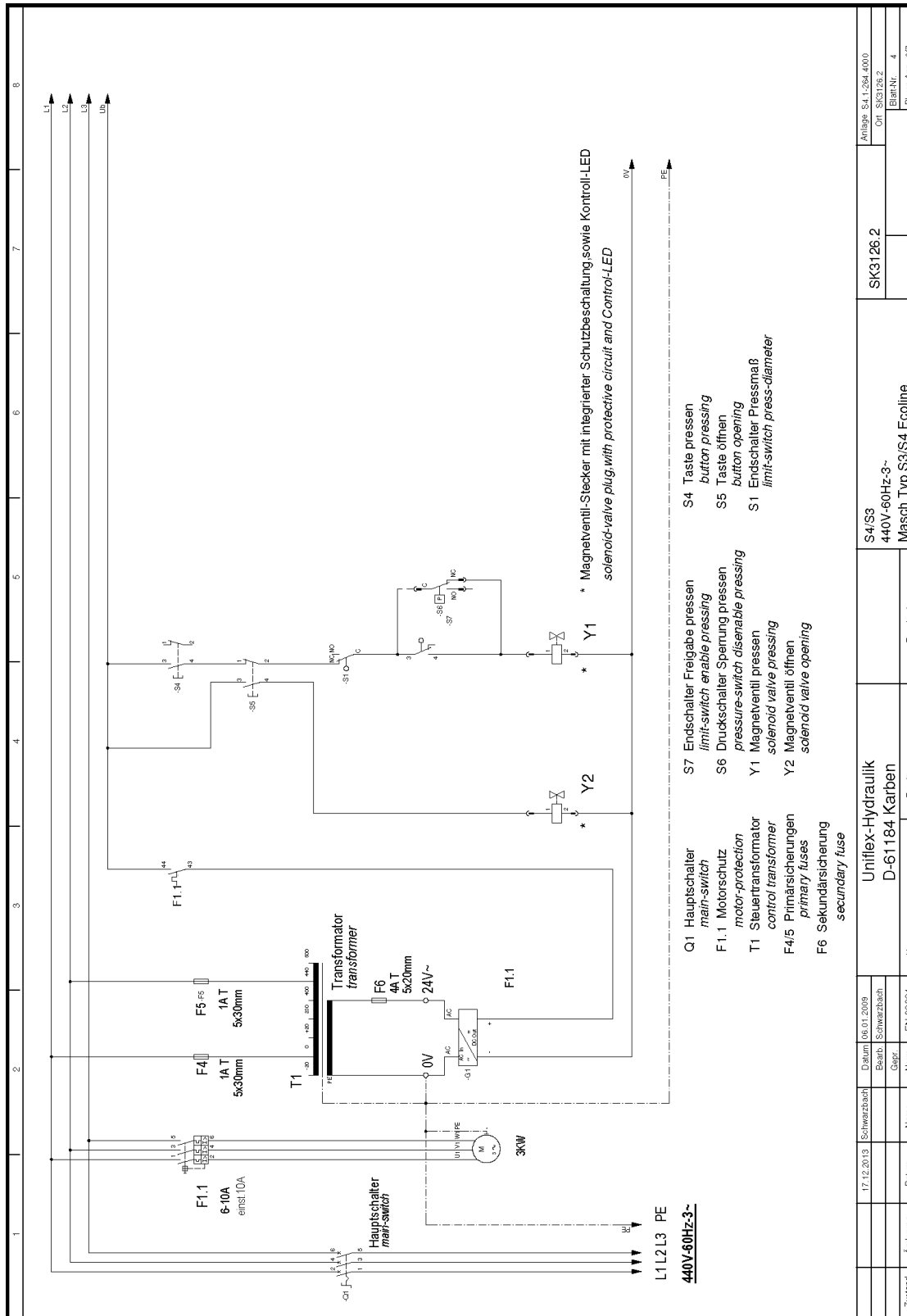

|            |          |             |        |             |                   |  |                          |          |                      |
|------------|----------|-------------|--------|-------------|-------------------|--|--------------------------|----------|----------------------|
| 17.12.2013 |          | Schwarzbach | Datum  | 06.01.2009  | Uniflex-Hydraulik |  | S4/S3                    | SK3126.2 | Anlage 54.1.264.4000 |
|            |          | Schwarzbach | Bearb. | Schwarzbach | D-61184 Karben    |  | 440V-60Hz-3~             |          | Ort SK3126.2         |
|            |          |             | Gepr.  |             | Ers. für          |  | Masch. Typ S3/S4 Ecoline |          | Blatt-Nr. 4          |
|            |          |             | Norm   | EN 60204    | Ers. durch        |  |                          |          | Bl. von Anz. 6/7     |
| Zustand    | Änderung | Datum       | Name   | Name        | Urspr.            |  |                          |          |                      |

# 9 Annex

## 9.8 Electric diagram

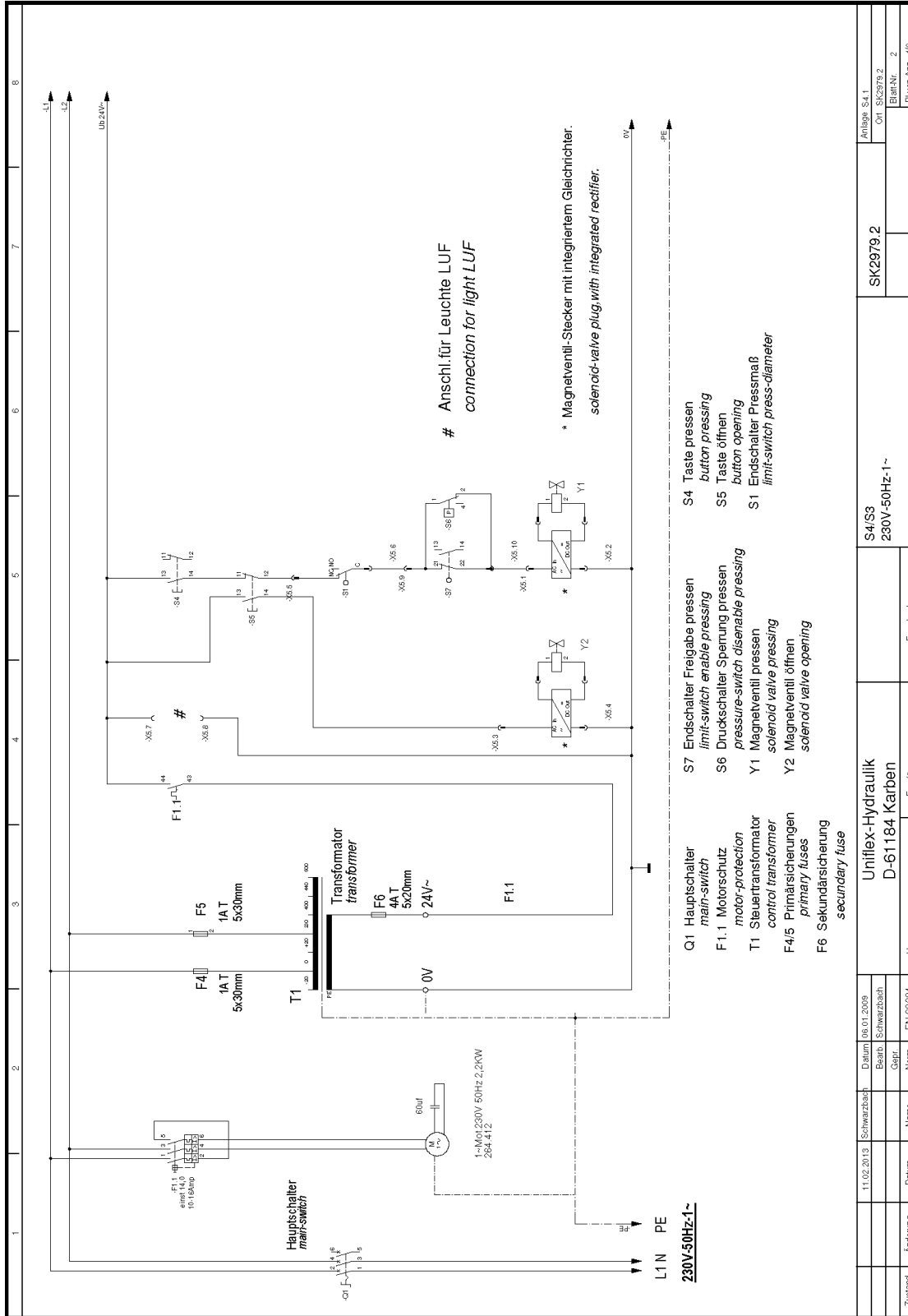

# 9 Annex

## 9.8 Electric diagram

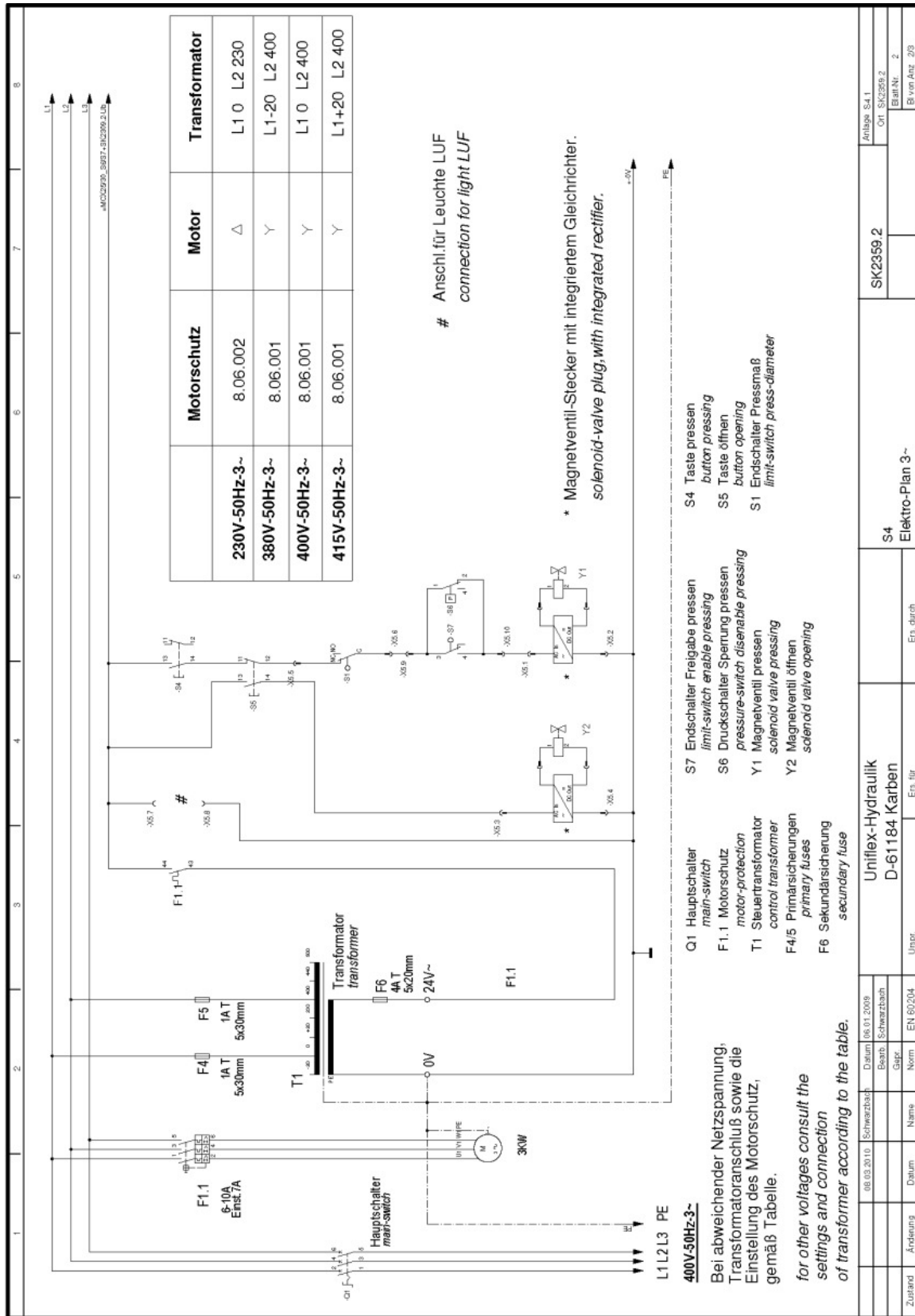

9 Annex  
9.9 Maintenance log

9.9 Maintenance log

| Hydraulic oil            | Hose assembly            | Retaining bolt           | Slide bearing plate      | Pressure springs         | Guiding plate            | Relay                    | Remark | Date | Signature |
|--------------------------|--------------------------|--------------------------|--------------------------|--------------------------|--------------------------|--------------------------|--------|------|-----------|
| <input type="checkbox"/> | <input type="checkbox"/> | <input type="checkbox"/> | <input type="checkbox"/> | <input type="checkbox"/> | <input type="checkbox"/> | <input type="checkbox"/> |        |      |           |
| <input type="checkbox"/> | <input type="checkbox"/> | <input type="checkbox"/> | <input type="checkbox"/> | <input type="checkbox"/> | <input type="checkbox"/> | <input type="checkbox"/> |        |      |           |
| <input type="checkbox"/> | <input type="checkbox"/> | <input type="checkbox"/> | <input type="checkbox"/> | <input type="checkbox"/> | <input type="checkbox"/> | <input type="checkbox"/> |        |      |           |
| <input type="checkbox"/> | <input type="checkbox"/> | <input type="checkbox"/> | <input type="checkbox"/> | <input type="checkbox"/> | <input type="checkbox"/> | <input type="checkbox"/> |        |      |           |
| <input type="checkbox"/> | <input type="checkbox"/> | <input type="checkbox"/> | <input type="checkbox"/> | <input type="checkbox"/> | <input type="checkbox"/> | <input type="checkbox"/> |        |      |           |
| <input type="checkbox"/> | <input type="checkbox"/> | <input type="checkbox"/> | <input type="checkbox"/> | <input type="checkbox"/> | <input type="checkbox"/> | <input type="checkbox"/> |        |      |           |
| <input type="checkbox"/> | <input type="checkbox"/> | <input type="checkbox"/> | <input type="checkbox"/> | <input type="checkbox"/> | <input type="checkbox"/> | <input type="checkbox"/> |        |      |           |
| <input type="checkbox"/> | <input type="checkbox"/> | <input type="checkbox"/> | <input type="checkbox"/> | <input type="checkbox"/> | <input type="checkbox"/> | <input type="checkbox"/> |        |      |           |
| <input type="checkbox"/> | <input type="checkbox"/> | <input type="checkbox"/> | <input type="checkbox"/> | <input type="checkbox"/> | <input type="checkbox"/> | <input type="checkbox"/> |        |      |           |
| <input type="checkbox"/> | <input type="checkbox"/> | <input type="checkbox"/> | <input type="checkbox"/> | <input type="checkbox"/> | <input type="checkbox"/> | <input type="checkbox"/> |        |      |           |
| <input type="checkbox"/> | <input type="checkbox"/> | <input type="checkbox"/> | <input type="checkbox"/> | <input type="checkbox"/> | <input type="checkbox"/> | <input type="checkbox"/> |        |      |           |
| <input type="checkbox"/> | <input type="checkbox"/> | <input type="checkbox"/> | <input type="checkbox"/> | <input type="checkbox"/> | <input type="checkbox"/> | <input type="checkbox"/> |        |      |           |
| <input type="checkbox"/> | <input type="checkbox"/> | <input type="checkbox"/> | <input type="checkbox"/> | <input type="checkbox"/> | <input type="checkbox"/> | <input type="checkbox"/> |        |      |           |
| <input type="checkbox"/> | <input type="checkbox"/> | <input type="checkbox"/> | <input type="checkbox"/> | <input type="checkbox"/> | <input type="checkbox"/> | <input type="checkbox"/> |        |      |           |
| <input type="checkbox"/> | <input type="checkbox"/> | <input type="checkbox"/> | <input type="checkbox"/> | <input type="checkbox"/> | <input type="checkbox"/> | <input type="checkbox"/> |        |      |           |
| <input type="checkbox"/> | <input type="checkbox"/> | <input type="checkbox"/> | <input type="checkbox"/> | <input type="checkbox"/> | <input type="checkbox"/> | <input type="checkbox"/> |        |      |           |
| <input type="checkbox"/> | <input type="checkbox"/> | <input type="checkbox"/> | <input type="checkbox"/> | <input type="checkbox"/> | <input type="checkbox"/> | <input type="checkbox"/> |        |      |           |
| <input type="checkbox"/> | <input type="checkbox"/> | <input type="checkbox"/> | <input type="checkbox"/> | <input type="checkbox"/> | <input type="checkbox"/> | <input type="checkbox"/> |        |      |           |
| <input type="checkbox"/> | <input type="checkbox"/> | <input type="checkbox"/> | <input type="checkbox"/> | <input type="checkbox"/> | <input type="checkbox"/> | <input type="checkbox"/> |        |      |           |
| <input type="checkbox"/> | <input type="checkbox"/> | <input type="checkbox"/> | <input type="checkbox"/> | <input type="checkbox"/> | <input type="checkbox"/> | <input type="checkbox"/> |        |      |           |
| <input type="checkbox"/> | <input type="checkbox"/> | <input type="checkbox"/> | <input type="checkbox"/> | <input type="checkbox"/> | <input type="checkbox"/> | <input type="checkbox"/> |        |      |           |
| <input type="checkbox"/> | <input type="checkbox"/> | <input type="checkbox"/> | <input type="checkbox"/> | <input type="checkbox"/> | <input type="checkbox"/> | <input type="checkbox"/> |        |      |           |
| <input type="checkbox"/> | <input type="checkbox"/> | <input type="checkbox"/> | <input type="checkbox"/> | <input type="checkbox"/> | <input type="checkbox"/> | <input type="checkbox"/> |        |      |           |
| <input type="checkbox"/> | <input type="checkbox"/> | <input type="checkbox"/> | <input type="checkbox"/> | <input type="checkbox"/> | <input type="checkbox"/> | <input type="checkbox"/> |        |      |           |
| <input type="checkbox"/> | <input type="checkbox"/> | <input type="checkbox"/> | <input type="checkbox"/> | <input type="checkbox"/> | <input type="checkbox"/> | <input type="checkbox"/> |        |      |           |
| <input type="checkbox"/> | <input type="checkbox"/> | <input type="checkbox"/> | <input type="checkbox"/> | <input type="checkbox"/> | <input type="checkbox"/> | <input type="checkbox"/> |        |      |           |
| <input type="checkbox"/> | <input type="checkbox"/> | <input type="checkbox"/> | <input type="checkbox"/> | <input type="checkbox"/> | <input type="checkbox"/> | <input type="checkbox"/> |        |      |           |
| <input type="checkbox"/> | <input type="checkbox"/> | <input type="checkbox"/> | <input type="checkbox"/> | <input type="checkbox"/> | <input type="checkbox"/> | <input type="checkbox"/> |        |      |           |
| <input type="checkbox"/> | <input type="checkbox"/> | <input type="checkbox"/> | <input type="checkbox"/> | <input type="checkbox"/> | <input type="checkbox"/> | <input type="checkbox"/> |        |      |           |
| <input type="checkbox"/> | <input type="checkbox"/> | <input type="checkbox"/> | <input type="checkbox"/> | <input type="checkbox"/> | <input type="checkbox"/> | <input type="checkbox"/> |        |      |           |
| <input type="checkbox"/> | <input type="checkbox"/> | <input type="checkbox"/> | <input type="checkbox"/> | <input type="checkbox"/> | <input type="checkbox"/> | <input type="checkbox"/> |        |      |           |
| <input type="checkbox"/> | <input type="checkbox"/> | <input type="checkbox"/> | <input type="checkbox"/> | <input type="checkbox"/> | <input type="checkbox"/> | <input type="checkbox"/> |        |      |           |
| <input type="checkbox"/> | <input type="checkbox"/> | <input type="checkbox"/> | <input type="checkbox"/> | <input type="checkbox"/> | <input type="checkbox"/> | <input type="checkbox"/> |        |      |           |
| <input type="checkbox"/> | <input type="checkbox"/> | <input type="checkbox"/> | <input type="checkbox"/> | <input type="checkbox"/> | <input type="checkbox"/> | <input type="checkbox"/> |        |      |           |
| <input type="checkbox"/> | <input type="checkbox"/> | <input type="checkbox"/> | <input type="checkbox"/> | <input type="checkbox"/> | <input type="checkbox"/> | <input type="checkbox"/> |        |      |           |
| <input type="checkbox"/> | <input type="checkbox"/> | <input type="checkbox"/> | <input type="checkbox"/> | <input type="checkbox"/> | <input type="checkbox"/> | <input type="checkbox"/> |        |      |           |
| <input type="checkbox"/> | <input type="checkbox"/> | <input type="checkbox"/> | <input type="checkbox"/> | <input type="checkbox"/> | <input type="checkbox"/> | <input type="checkbox"/> |        |      |           |
| <input type="checkbox"/> | <input type="checkbox"/> | <input type="checkbox"/> | <input type="checkbox"/> | <input type="checkbox"/> | <input type="checkbox"/> | <input type="checkbox"/> |        |      |           |
| <input type="checkbox"/> | <input type="checkbox"/> | <input type="checkbox"/> | <input type="checkbox"/> | <input type="checkbox"/> | <input type="checkbox"/> | <input type="checkbox"/> |        |      |           |
| <input type="checkbox"/> | <input type="checkbox"/> | <input type="checkbox"/> | <input type="checkbox"/> | <input type="checkbox"/> | <input type="checkbox"/> | <input type="checkbox"/> |        |      |           |
| <input type="checkbox"/> | <input type="checkbox"/> | <input type="checkbox"/> | <input type="checkbox"/> | <input type="checkbox"/> | <input type="checkbox"/> | <input type="checkbox"/> |        |      |           |
| <input type="checkbox"/> | <input type="checkbox"/> | <input type="checkbox"/> | <input type="checkbox"/> | <input type="checkbox"/> | <input type="checkbox"/> | <input type="checkbox"/> |        |      |           |
| <input type="checkbox"/> | <input type="checkbox"/> | <input type="checkbox"/> | <input type="checkbox"/> | <input type="checkbox"/> | <input type="checkbox"/> | <input type="checkbox"/> |        |      |           |
| <input type="checkbox"/> | <input type="checkbox"/> | <input type="checkbox"/> | <input type="checkbox"/> | <input type="checkbox"/> | <input type="checkbox"/> | <input type="checkbox"/> |        |      |           |
| <input type="checkbox"/> | <input type="checkbox"/> | <input type="checkbox"/> | <input type="checkbox"/> | <input type="checkbox"/> | <input type="checkbox"/> | <input type="checkbox"/> |        |      |           |
| <input type="checkbox"/> | <input type="checkbox"/> | <input type="checkbox"/> | <input type="checkbox"/> | <input type="checkbox"/> | <input type="checkbox"/> | <input type="checkbox"/> |        |      |           |
| <input type="checkbox"/> | <input type="checkbox"/> | <input type="checkbox"/> | <input type="checkbox"/> | <input type="checkbox"/> | <input type="checkbox"/> | <input type="checkbox"/> |        |      |           |
| <input type="checkbox"/> | <input type="checkbox"/> | <input type="checkbox"/> | <input type="checkbox"/> | <input type="checkbox"/> | <input type="checkbox"/> | <input type="checkbox"/> |        |      |           |
| <input type="checkbox"/> | <input type="checkbox"/> | <input type="checkbox"/> | <input type="checkbox"/> | <input type="checkbox"/> | <input type="checkbox"/> | <input type="checkbox"/> |        |      |           |
| <input type="checkbox"/> | <input type="checkbox"/> | <input type="checkbox"/> | <input type="checkbox"/> | <input type="checkbox"/> | <input type="checkbox"/> | <input type="checkbox"/> |        |      |           |
| <input type="checkbox"/> | <input type="checkbox"/> | <input type="checkbox"/> | <input type="checkbox"/> | <input type="checkbox"/> | <input type="checkbox"/> | <input type="checkbox"/> |        |      |           |
| <input type="checkbox"/> | <input type="checkbox"/> | <input type="checkbox"/> | <input type="checkbox"/> | <input type="checkbox"/> | <input type="checkbox"/> | <input type="checkbox"/> |        |      |           |
| <input type="checkbox"/> | <input type="checkbox"/> | <input type="checkbox"/> | <input type="checkbox"/> | <input type="checkbox"/> | <input type="checkbox"/> | <input type="checkbox"/> |        |      |           |
| <input type="checkbox"/> | <input type="checkbox"/> | <input type="checkbox"/> | <input type="checkbox"/> | <input type="checkbox"/> | <input type="checkbox"/> | <input type="checkbox"/> |        |      |           |
| <input type="checkbox"/> | <input type="checkbox"/> | <input type="checkbox"/> | <input type="checkbox"/> | <input type="checkbox"/> | <input type="checkbox"/> | <input type="checkbox"/> |        |      |           |
| <input type="checkbox"/> | <input type="checkbox"/> | <input type="checkbox"/> | <input type="checkbox"/> | <input type="checkbox"/> | <input type="checkbox"/> | <input type="checkbox"/> |        |      |           |
| <input type="checkbox"/> | <input type="checkbox"/> | <input type="checkbox"/> | <input type="checkbox"/> | <input type="checkbox"/> | <input type="checkbox"/> | <input type="checkbox"/> |        |      |           |
| <input type="checkbox"/> | <input type="checkbox"/> | <input type="checkbox"/> | <input type="checkbox"/> | <input type="checkbox"/> | <input type="checkbox"/> | <input type="checkbox"/> |        |      |           |
| <input type="checkbox"/> | <input type="checkbox"/> | <input type="checkbox"/> | <input type="checkbox"/> | <input type="checkbox"/> | <input type="checkbox"/> | <input type="checkbox"/> |        |      |           |
| <input type="checkbox"/> | <input type="checkbox"/> | <input type="checkbox"/> | <input type="checkbox"/> | <input type="checkbox"/> | <input type="checkbox"/> | <input type="checkbox"/> |        |      |           |
| <input type="checkbox"/> | <input type="checkbox"/> | <input type="checkbox"/> | <input type="checkbox"/> | <input type="checkbox"/> | <input type="checkbox"/> | <input type="checkbox"/> |        |      |           |
| <input type="checkbox"/> | <input type="checkbox"/> | <input type="checkbox"/> | <input type="checkbox"/> | <input type="checkbox"/> | <input type="checkbox"/> | <input type="checkbox"/> |        |      |           |
| <input type="checkbox"/> | <input type="checkbox"/> | <input type="checkbox"/> | <input type="checkbox"/> | <input type="checkbox"/> | <input type="checkbox"/> | <input type="checkbox"/> |        |      |           |
| <input type="checkbox"/> | <input type="checkbox"/> | <input type="checkbox"/> | <input type="checkbox"/> | <input type="checkbox"/> | <input type="checkbox"/> | <input type="checkbox"/> |        |      |           |
| <input type="checkbox"/> | <input type="checkbox"/> | <input type="checkbox"/> | <input type="checkbox"/> | <input type="checkbox"/> | <input type="checkbox"/> | <input type="checkbox"/> |        |      |           |
| <input type="checkbox"/> | <input type="checkbox"/> | <input type="checkbox"/> | <input type="checkbox"/> | <input type="checkbox"/> | <input type="checkbox"/> | <input type="checkbox"/> |        |      |           |
| <input type="checkbox"/> | <input type="checkbox"/> | <input type="checkbox"/> | <input type="checkbox"/> | <input type="checkbox"/> | <input type="checkbox"/> | <input type="checkbox"/> |        |      |           |
| <input type="checkbox"/> | <input type="checkbox"/> | <input type="checkbox"/> | <input type="checkbox"/> | <input type="checkbox"/> | <input type="checkbox"/> | <input type="checkbox"/> |        |      |           |
| <input type="checkbox"/> | <input type="checkbox"/> | <input type="checkbox"/> | <input type="checkbox"/> | <input type="checkbox"/> | <input type="checkbox"/> | <input type="checkbox"/> |        |      |           |
| <input type="checkbox"/> | <input type="checkbox"/> | <input type="checkbox"/> | <input type="checkbox"/> | <input type="checkbox"/> | <input type="checkbox"/> | <input type="checkbox"/> |        |      |           |
| <input type="checkbox"/> | <input type="checkbox"/> | <input type="checkbox"/> | <input type="checkbox"/> | <input type="checkbox"/> | <input type="checkbox"/> | <input type="checkbox"/> |        |      |           |
| <input type="checkbox"/> | <input type="checkbox"/> | <input type="checkbox"/> | <input type="checkbox"/> | <input type="checkbox"/> | <input type="checkbox"/> | <input type="checkbox"/> |        |      |           |
| <input type="checkbox"/> | <input type="checkbox"/> | <input type="checkbox"/> | <input type="checkbox"/> | <input type="checkbox"/> | <input type="checkbox"/> | <input type="checkbox"/> |        |      |           |
| <input type="checkbox"/> | <input type="checkbox"/> | <input type="checkbox"/> | <input type="checkbox"/> | <input type="checkbox"/> | <input type="checkbox"/> | <input type="checkbox"/> |        |      |           |
| <input type="checkbox"/> | <input type="checkbox"/> | <input type="checkbox"/> | <input type="checkbox"/> | <input type="checkbox"/> | <input type="checkbox"/> | <input type="checkbox"/> |        |      |           |
| <input type="checkbox"/> | <input type="checkbox"/> | <input type="checkbox"/> | <input type="checkbox"/> | <input type="checkbox"/> | <input type="checkbox"/> | <input type="checkbox"/> |        |      |           |
| <input type="checkbox"/> | <input type="checkbox"/> | <input type="checkbox"/> | <input type="checkbox"/> | <input type="checkbox"/> | <input type="checkbox"/> | <input type="checkbox"/> |        |      |           |
| <input type="checkbox"/> | <input type="checkbox"/> | <input type="checkbox"/> | <input type="checkbox"/> | <input type="checkbox"/> | <input type="checkbox"/> | <input type="checkbox"/> |        |      |           |
| <input type="checkbox"/> | <input type="checkbox"/> | <input type="checkbox"/> | <input type="checkbox"/> | <input type="checkbox"/> | <input type="checkbox"/> | <input type="checkbox"/> |        |      |           |
| <input type="checkbox"/> | <input type="checkbox"/> | <input type="checkbox"/> | <input type="checkbox"/> | <input type="checkbox"/> | <input type="checkbox"/> | <input type="checkbox"/> |        |      |           |
| <input type="checkbox"/> | <input type="checkbox"/> | <input type="checkbox"/> | <input type="checkbox"/> | <input type="checkbox"/> | <input type="checkbox"/> | <input type="checkbox"/> |        |      |           |
| <input type="checkbox"/> | <input type="checkbox"/> | <input type="checkbox"/> | <input type="checkbox"/> | <input type="checkbox"/> | <input type="checkbox"/> | <input type="checkbox"/> |        |      |           |
| <input type="checkbox"/> | <input type="checkbox"/> | <input type="checkbox"/> | <input type="checkbox"/> | <input type="checkbox"/> | <input type="checkbox"/> | <input type="checkbox"/> |        |      |           |
| <input type="checkbox"/> | <input type="checkbox"/> | <input type="checkbox"/> | <input type="checkbox"/> | <input type="checkbox"/> | <input type="checkbox"/> | <input type="checkbox"/> |        |      |           |
| <input type="checkbox"/> | <input type="checkbox"/> | <input type="checkbox"/> | <input type="checkbox"/> | <input type="checkbox"/> | <input type="checkbox"/> | <input type="checkbox"/> |        |      |           |
| <input type="checkbox"/> | <input type="checkbox"/> | <input type="checkbox"/> | <input type="checkbox"/> | <input type="checkbox"/> | <input type="checkbox"/> | <input type="checkbox"/> |        |      |           |
| <input type="checkbox"/> | <input type="checkbox"/> | <input type="checkbox"/> | <input type="checkbox"/> | <input type="checkbox"/> | <input type="checkbox"/> | <input type="checkbox"/> |        |      |           |
| <input type="checkbox"/> | <input type="checkbox"/> | <input type="checkbox"/> | <input type="checkbox"/> | <input type="checkbox"/> | <input type="checkbox"/> | <input type="checkbox"/> |        |      |           |
| <input type="checkbox"/> | <input type="checkbox"/> | <input type="checkbox"/> | <input type="checkbox"/> | <input type="checkbox"/> | <input type="checkbox"/> | <input type="checkbox"/> |        |      |           |
| <input type="checkbox"/> | <input type="checkbox"/> | <input type="checkbox"/> | <input type="checkbox"/> | <input type="checkbox"/> | <input type="checkbox"/> | <input type="checkbox"/> |        |      |           |
| <input type="checkbox"/> | <input type="checkbox"/> | <input type="checkbox"/> | <input type="checkbox"/> | <input type="checkbox"/> | <input type="checkbox"/> | <input type="checkbox"/> |        |      |           |
| <input type="checkbox"/> | <input type="checkbox"/> | <input type="checkbox"/> | <input type="checkbox"/> | <input type="checkbox"/> | <input type="checkbox"/> | <input type="checkbox"/> |        |      |           |
| <input type="checkbox"/> | <input type="checkbox"/> | <input type="checkbox"/> | <input type="checkbox"/> | <input type="checkbox"/> | <input type="checkbox"/> | <input type="checkbox"/> |        |      |           |
| <input type="checkbox"/> | <input type="checkbox"/> | <input type="checkbox"/> | <input type="checkbox"/> | <input type="checkbox"/> | <input type="checkbox"/> | <input type="checkbox"/> |        |      |           |
| <input type="checkbox"/> | <input type="checkbox"/> | <input type="checkbox"/> | <input type="checkbox"/> | <input type="checkbox"/> | <input type="checkbox"/> | <input type="checkbox"/> |        |      |           |
| <input type="checkbox"/> | <input type="checkbox"/> | <input type="checkbox"/> | <input type="checkbox"/> | <input type="checkbox"/> | <input type="checkbox"/> | <input type="checkbox"/> |        |      |           |
| <input type="checkbox"/> | <input type="checkbox"/> | <input type="checkbox"/> | <input type="checkbox"/> | <input type="checkbox"/> | <input type="checkbox"/> | <input type="checkbox"/> |        |      |           |
| <input type="checkbox"/> | <input type="checkbox"/> | <input type="checkbox"/> | <input type="checkbox"/> | <input type="checkbox"/> | <input type="checkbox"/> | <input type="checkbox"/> |        |      |           |
| <input type="checkbox"/> | <input type="checkbox"/> | <input type="checkbox"/> | <input type="checkbox"/> | <input type="checkbox"/> | <input type="checkbox"/> | <input type="checkbox"/> |        |      |           |
| <input type="checkbox"/> | <input type="checkbox"/> | <input type="checkbox"/> | <input type="checkbox"/> | <input type="checkbox"/> | <input type="checkbox"/> | <input type="checkbox"/> |        |      |           |
| <input type="checkbox"/> | <input type="checkbox"/> | <input type="checkbox"/> | <input type="checkbox"/> | <input type="checkbox"/> | <input type="checkbox"/> | <input type="checkbox"/> |        |      |           |
| <input type="checkbox"/> | <input type="checkbox"/> | <input type="checkbox"/> | <input type="checkbox"/> | <input type="checkbox"/> | <input type="checkbox"/> | <input type="checkbox"/> |        |      |           |
| <input type="checkbox"/> | <input type="checkbox"/> | <input type="checkbox"/> | <input type="checkbox"/> | <input type="checkbox"/> | <input type="checkbox"/> | <input type="checkbox"/> |        |      |           |
| <input type="checkbox"/> | <input type="checkbox"/> | <input type="checkbox"/> | <input type="checkbox"/> | <input type="checkbox"/> | <input type="checkbox"/> | <input type="checkbox"/> |        |      |           |
| <input type="checkbox"/> | <input type="checkbox"/> | <input type="checkbox"/> | <input type="checkbox"/> | <input type="checkbox"/> | <input type="checkbox"/> | <input type="checkbox"/> |        |      |           |
| <input type="checkbox"/> | <input type="checkbox"/> | <input type="checkbox"/> | <input type="checkbox"/> | <input type="checkbox"/> | <input type="checkbox"/> | <input type="checkbox"/> |        |      |           |
| <input type="checkbox"/> | <input type="checkbox"/> | <input type="checkbox"/> | <input type="checkbox"/> | <input type="checkbox"/> | <input type="checkbox"/> | <input type="checkbox"/> |        |      |           |
| <input type="checkbox"/> | <input type="checkbox"/> | <input type="checkbox"/> | <input type="checkbox"/> | <input type="checkbox"/> | <input type="checkbox"/> | <input type="checkbox"/> |        |      |           |
| <input type="checkbox"/> | <input type="checkbox"/> | <input type="checkbox"/> | <input type="checkbox"/> | <input type="checkbox"/> | <input type="checkbox"/> | <input type="checkbox"/> |        |      |           |
| <input type="checkbox"/> | <input type="checkbox"/> | <input type="checkbox"/> | <input type="checkbox"/> | <input type="checkbox"/> | <input type="checkbox"/> | <input type="checkbox"/> |        |      |           |
| <input type="checkbox"/> | <input type="checkbox"/> | <input type="checkbox"/> | <input type="checkbox"/> | <input type="checkbox"/> | <input type="checkbox"/> | <input type="checkbox"/> |        |      |           |
| <input type="checkbox"/> | <input type="checkbox"/> | <input type="checkbox"/> | <input type="checkbox"/> | <input type="checkbox"/> | <input type="checkbox"/> | <input type="checkbox"/> |        |      |           |
| <input type="checkbox"/> | <input type="checkbox"/> | <input type="checkbox"/> | <input type="checkbox"/> | <input type="checkbox"/> | <input type="checkbox"/> | <input type="checkbox"/> |        |      |           |
| <input type="checkbox"/> | <input type="checkbox"/> | <input type="checkbox"/> | <input type="checkbox"/> | <input type="checkbox"/> | <input type="checkbox"/> | <input type="checkbox"/> |        |      |           |
| <input type="checkbox"/> | <input type="checkbox"/> | <input type="checkbox"/> | <input type="checkbox"/> | <input type="checkbox"/> | <input type="checkbox"/> | <input type="checkbox"/> |        |      |           |
| <input type="checkbox"/> | <input type="checkbox"/> | <input type="checkbox"/> | <input type="checkbox"/> | <input type="checkbox"/> | <input type="checkbox"/> | <input type="checkbox"/> |        |      |           |
| <input type="checkbox"/> | <input type="checkbox"/> | <input type="checkbox"/> | <input type="checkbox"/> | <input type="checkbox"/> | <input type="checkbox"/> | <input type="checkbox"/> |        |      |           |
| <input type="checkbox"/> | <input type="checkbox"/> | <input type="checkbox"/> | <input type="checkbox"/> | <input type="checkbox"/> | <input type="checkbox"/> | <input type="checkbox"/> |        |      |           |
| <input type="checkbox"/> | <input type="checkbox"/> | <input type="checkbox"/> | <input type="checkbox"/> | <input type="checkbox"/> | <input type="checkbox"/> | <input type="checkbox"/> |        |      |           |
| <input type="checkbox"/> | <input type="checkbox"/> | <input type="checkbox"/> | <input type="checkbox"/> | <input type="checkbox"/> | <input type="checkbox"/> | <input type="checkbox"/> |        |      |           |
| <input type="checkbox"/> | <input type="checkbox"/> | <input type="checkbox"/> | <input type="checkbox"/> | <input type="checkbox"/> | <input type="checkbox"/> | <input type="checkbox"/> |        |      |           |
| <input type="checkbox"/> | <input type="checkbox"/> | <input type="checkbox"/> | <input type="checkbox"/> | <input type="checkbox"/> | <input type="checkbox"/> | <input type="checkbox"/> |        |      |           |
| <input type="checkbox"/> | <input type="checkbox"/> | <input type="checkbox"/> | <input type="checkbox"/> | <input type="checkbox"/> | <input type="checkbox"/> | <input type="checkbox"/> |        |      |           |
| <input type="checkbox"/> | <input type="checkbox"/> | <input type="checkbox"/> | <input type="checkbox"/> | <input type="checkbox"/> | <input type="checkbox"/> | <input type="checkbox"/> |        |      |           |
| <input type="checkbox"/> | <input type="checkbox"/> | <input type="checkbox"/> | <input type="checkbox"/> | <input type="checkbox"/> | <input type="checkbox"/> | <input type="checkbox"/> |        |      |           |
| <input type="checkbox"/> | <input type="checkbox"/> | <input type="checkbox"/> | <input type="checkbox"/> | <input type="checkbox"/> | <input type="checkbox"/> | <input type="checkbox"/> |        |      |           |
| <input type="checkbox"/> | <input type="checkbox"/> | <input type="checkbox"/> | <input type="checkbox"/> | <input type="checkbox"/> | <input type="checkbox"/> | <input type="checkbox"/> |        |      |           |
| <input type="checkbox"/> | <input type="checkbox"/> | <input type="checkbox"/> | <input type="checkbox"/> | <input type="checkbox"/> | <input type="checkbox"/> | <input type="checkbox"/> |        |      |           |
| <input type="checkbox"/> | <input type="checkbox"/> | <input type="checkbox"/> | <input type="checkbox"/> | <input type="checkbox"/> | <input type="checkbox"/> | <input type="checkbox"/> |        |      |           |
| <input type="checkbox"/> | <input type="checkbox"/> | <input type="checkbox"/> | <input type="checkbox"/> | <input type="checkbox"/> | <input type="checkbox"/> | <input type="checkbox"/> |        |      |           |
| <input type="checkbox"/> | <input type="checkbox"/> | <input type="checkbox"/> | <input type="checkbox"/> | <input type="checkbox"/> | <input type="checkbox"/> | <input type="checkbox"/> |        |      |           |
| <input type="checkbox"/> | <input type="checkbox"/> | <input type="checkbox"/> | <input type="checkbox"/> | <input type="checkbox"/> | <input type="checkbox"/> | <input type="checkbox"/> |        |      |           |
| <input type="checkbox"/> | <input type="checkbox"/> | <input type="checkbox"/> | <input type="checkbox"/> | <input type="checkbox"/> | <input type="checkbox"/> | <input type="checkbox"/> |        |      |           |
| <input type="checkbox"/> | <input type="checkbox"/> | <input type="checkbox"/> | <input type="checkbox"/> | <input type="checkbox"/> | <input type="checkbox"/> | <input type="checkbox"/> |        |      |           |
| <input type="checkbox"/> | <input type="checkbox"/> | <input type="checkbox"/> | <input type="checkbox"/> | <input type="checkbox"/> | <input type="checkbox"/> | <input type="checkbox"/> |        |      |           |
| <input type="checkbox"/> | <input type="checkbox"/> | <input type="checkbox"/> | <input type="checkbox"/> | <input type="checkbox"/> | <input type="checkbox"/> | <input type="checkbox"/> |        |      |           |
| <input type="checkbox"/> | <input type="checkbox"/> | <input type="checkbox"/> | <input type="checkbox"/> | <input type="checkbox"/> | <input type="checkbox"/> | <input type="checkbox"/> |        |      |           |
| <input type="checkbox"/> | <input type="checkbox"/> | <input type="checkbox"/> | <input type="checkbox"/> | <input type="checkbox"/> | <input type="checkbox"/> | <input type="checkbox"/> |        |      |           |
| <input type="checkbox"/> | <input type="checkbox"/> | <input type="checkbox"/> | <input type="checkbox"/> | <input type="checkbox"/> | <input type="checkbox"/> | <input type="checkbox"/> |        |      |           |
| <input type="checkbox"/> | <input type="checkbox"/> | <input type="checkbox"/> | <input type="checkbox"/> | <input type="checkbox"/> | <input type="checkbox"/> | <input type="checkbox"/> |        |      |           |
| <input type="checkbox"/> | <input type="checkbox"/> | <input type="checkbox"/> | <input type="checkbox"/> | <input type="checkbox"/> | <input type="checkbox"/> | <input type="checkbox"/> |        |      |           |
| <input type="checkbox"/> | <input type="checkbox"/> | <input type="checkbox"/> | <input type="checkbox"/> | <input type="checkbox"/> | <input type="checkbox"/> | <input type="checkbox"/> |        |      |           |
| <input type="checkbox"/> | <input type="checkbox"/> | <input type="checkbox"/> | <input type="checkbox"/> | <input type="checkbox"/> | <input type="checkbox"/> | <input type="checkbox"/> |        |      |           |
| <input type="checkbox"/> | <input type="checkbox"/> | <input type="checkbox"/> | <input type="checkbox"/> | <input type="checkbox"/> | <input type="checkbox"/> | <input type="checkbox"/> |        |      |           |
| <input type="checkbox"/> | <input type="checkbox"/> | <input type="checkbox"/> | <input type="checkbox"/> | <input type="checkbox"/> | <input type="checkbox"/> | <input type="checkbox"/> |        |      |           |
| <input type="checkbox"/> | <input type="checkbox"/> | <input type="checkbox"/> | <input type="checkbox"/> | <input type="checkbox"/> | <input type="checkbox"/> | <input type="checkbox"/> |        |      |           |
| <input type="checkbox"/> | <input type="checkbox"/> | <input type="checkbox"/> | <input type="checkbox"/> | <input type="checkbox"/> | <input type="checkbox"/> | <input type="checkbox"/> |        |      |           |
| <input type="checkbox"/> | <input type="checkbox"/> | <input type="checkbox"/> | <input type="checkbox"/> | <input type="checkbox"/> | <input type="checkbox"/> | <input type="checkbox"/> |        |      |           |
| <input type="checkbox"/> | <input type="checkbox"/> | <input type="checkbox"/> | <input type="checkbox"/> | <input type="checkbox"/> | <input type="checkbox"/> | <input type="checkbox"/> |        |      |           |
| <input type="checkbox"/> | <input type="checkbox"/> | <input type="checkbox"/> | <input type="checkbox"/> | <input type="checkbox"/> | <input type="checkbox"/> | <input type="checkbox"/> |        |      |           |
| <input type="checkbox"/> | <input type="checkbox"/> | <input type="checkbox"/> | <input type="checkbox"/> | <input type="checkbox"/> | <input type="checkbox"/> | <input type="checkbox"/> |        |      |           |
| <input type="checkbox"/> | <input type="checkbox"/> | <input type="checkbox"/> | <input type="checkbox"/> | <input type="checkbox"/> | <input type="checkbox"/> | <input type="checkbox"/> |        |      |           |
| <input type="checkbox"/> | <input type="checkbox"/> | <input type="checkbox"/> | <input type="checkbox"/> | <input type="checkbox"/> | <input type="checkbox"/> | <input type="checkbox"/> |        |      |           |
| <input type="checkbox"/> | <input type="checkbox"/> | <input type="checkbox"/> | <input type="checkbox"/> | <input type="checkbox"/> | <input type="checkbox"/> | <input type="checkbox"/> |        |      |           |
| <input type="checkbox"/> | <input type="checkbox"/> |                          |                          |                          |                          |                          |        |      |           |

## 9 Annex

### 9.10 Declaration of qualified staff

---

#### 9.10 Declaration of qualified staff

I herewith declare that I have attended an internal training for the operation of the UNIFLEX machine and have been informed on all safety-related details. In addition I declare that I have read and understood this Operation Manual completely.

|      |      |      |           |
|------|------|------|-----------|
|      |      |      |           |
| City | Date | Name | Signature |

|      |      |      |           |
|------|------|------|-----------|
|      |      |      |           |
| City | Date | Name | Signature |

|      |      |      |           |
|------|------|------|-----------|
|      |      |      |           |
| City | Date | Name | Signature |

|      |      |      |           |
|------|------|------|-----------|
|      |      |      |           |
| City | Date | Name | Signature |

|      |      |      |           |
|------|------|------|-----------|
|      |      |      |           |
| City | Date | Name | Signature |

|      |      |      |           |
|------|------|------|-----------|
|      |      |      |           |
| City | Date | Name | Signature |

## 9 Annex

### 9.10 Declaration of qualified staff

---

## About Danfoss Power Solutions FC

We sincerely appreciate your choice in selecting this product as part of the range of tooling products distributed by Danfoss.

Danfoss hoses, fittings, and tooling provide the ultimate fluid conveyance solutions for a variety of equipment and applications around the world. We proudly engineer to support a sustainable future for tomorrow.

To learn more please visit: <http://www.danfoss.com/en/about-danfoss/our-businesses/power-solutions>

### **Danfoss Power Solutions**

14615 Lone Oak Road  
Eden Prairie, MN 55344, USA  
Phone: 952-937-9800

### **Danfoss Power Solutions II GmbH**

Fluid Conveyance  
Dr. -Reckeweg-Str. 1  
DE-76532 Baden-Baden  
Tel.: +49 7221 6820  
Machine and tooling selection hotline: [FcMachineSupportEMEA@danfoss.com](mailto:FcMachineSupportEMEA@danfoss.com)  
Service and repair Hotline: [FcMachineRepairsEMEA@danfoss.com](mailto:FcMachineRepairsEMEA@danfoss.com)

### **Danfoss Power Solutions (US) Company**

2800 East 13th Street  
Ames, IA 50010, USA  
Phone: +1 515-239-6000

### **Danfoss Power Solutions GmbH & Co.OHG**

Krokamp 35  
D-2439 Neumünster, Germany  
Phone: +49 4321 871 0

### **Danfoss Power Solutions ApS**

Nordborgvej 81  
DK-6430 Nordborg, Denmark  
Phone: +45 7488 2222

### **Danfoss Power Solutions Trade (Shanghai) Co. Ltd.**

Building #22, No 1000 Jin Hai Rd  
Jin Qiao, Pudong New District  
Shanghai, China 201206  
Phone: +86 21 3418 5200w

Thank you for participating in the Danfoss tooling program. We are pleased to offer you high-quality tooling machines manufactured by our trusted partner, Uniflex. These machines are designed to meet the rigorous standards of our industry, ensuring reliability, precision, and efficiency in your operations. We are committed to providing you with the best tools to support your success.

---

Danfoss can accept no responsibility for possible errors in catalogs, brochures, and other printed material. Danfoss reserves the right to alter its products without notice. This also applies to products already on order provided that such alterations can be made without subsequent changes being necessary in specifications already agreed. All trademarks in this material are the property of the respective companies.

Danfoss and the Danfoss logotype are trademarks of Danfoss A/S. All rights reserved.