

ENGINEERING
TOMORROW

Danfoss

Operator's Manual

ET9700 Cutting Machine



Imprint

Manufacturer:

UNIFLEX-Hydraulik GmbH
Robert-Bosch-Strasse 50-52
D-61184 Karben
Germany

Phone: +49 (0) 60 39 / 91 71 - 0

Fax: +49 (0) 60 39 / 91 71 - 181

This Operating Manual of the machine is a translation; the original is in German.

Date of revision: 2024-07-22

Version: 1.2

© Copyright by UNIFLEX-Hydraulik GmbH

Technical modifications reserved.

The reproduction, distribution and utilization of this document as well as the communication of its contents to others without explicit authorization are prohibited. Offenders will be held liable for the payment of damages. All rights reserved in the event of the grant of a patent, utility model or design.

EC / UK - Declaration of Conformity

In accordance with EC Machinery Directive 2006/42/EC and UK-Supply of Machinery (Safety) Regulations 2008.

The following machine

ET9700

was developed, designed and manufactured in compliance with EC Directive 2006/42/EC and UK-Supply of Machinery (Safety) Regulations 2008, in the sole responsibility of

UNIFLEX-Hydraulik GmbH
Robert-Bosch-Strasse 50 - 52
D-61184 Karben

The following standards, codes and specifications have been applied:

- EC Directive 2006/42/EC
- EMC Directive 2014/30/EC
- EN ISO 12100: 2010
- EN 60204-1: 2018
- UK-Supply of Machinery (Safety) Regulations 2008
- UK-Electromagnetic Compatibility Regulations 2016

This declaration are invalid when the machine is modified or if unauthorized and unapproved third-party components are used without our prior approval.

Entity authorised for documentation: Uniflex-Hydraulik GmbH, Technical Documentation Dept.

Karben, 10.10.2022



Managing Director Harald von Waitz

Contents

1	About this document	7
1.1	Target groups	7
1.2	Storage	9
1.3	Name plate	9
1.4	Abbreviations	9
2	Safety instructions	10
2.1	Presentation of warnings	10
2.2	Intended use	11
2.3	Product-specific risks	12
2.3.1	Risks imposed by mechanical equipment	12
2.3.2	Risks imposed by electricity	12
2.3.3	Risk imposed by pneumatic system	13
2.3.4	Risks imposed by noise	13
2.3.5	Risks in case of fire	13
2.4	Safety	14
2.4.1	Working area	14
2.4.2	Warning signs on the machine	15
3	Machine description	17
3.1	Design and function	17
3.2	Technical data	19
4	Transport and commissioning	21
4.1	Transport	21
4.2	Intermediate storage of machine/unit	22
4.3	Commissioning	23
4.3.1	Extraction process for TM/TMG cutting knife	24
4.3.2	Extraction process for TMC cutting knife	25
4.3.3	Connection of compressed air	26
4.3.4	Electrical connection	27
5	Operation	29
5.1	What you have to observe	29
5.2	Start	29
5.3	Replacing the cutting fork	30
5.4	Workpiece cutting	30

Contents

5.4.1	Prerequisites.....	30
5.4.2	Aligning the bending pins.....	32
5.4.3	Setting the cutting speed.....	33
5.4.4	Setting the return stroke.....	35
5.4.5	Cut counter.....	37
5.4.6	Individual cutting of work pieces.....	38
5.4.7	Continuous cutting of work pieces.....	39
5.5	Stop.....	40
5.6	Overload protection.....	41
5.7	Cleaning.....	41
6	Maintenance.....	42
6.1	What you have to observe.....	42
6.2	Maintenance schedule.....	42
6.3	Replacing the cutting knife.....	44
6.3.1	Replacing a resharpened cutting knife.....	46
6.4	Checking the motor brake.....	50
6.5	Motor brake readjustment.....	51
6.5.1	Motor brake variants.....	51
7	Troubleshooting.....	55
8	Decommissioning, disposal.....	56
8.1	Dismantling.....	56
8.2	Recycling.....	56
8.3	Consumables and waste.....	57
9	Annex.....	58
9.1	Accessories (retrofitable).....	58
9.2	Spare parts list.....	59
9.2.1	Mechanical equipment.....	59
9.2.2	Pneumatic.....	61
9.2.3	Electric equipment.....	62
9.2.4	Electric control unit.....	63
9.2.5	Wear parts.....	64
9.3	Electric diagram.....	65
9.4	Pneumatic diagram.....	68
9.5	Maintenance log.....	69
9.6	Declaration of qualified staff.....	70

Contents

1 About this document

1.1 Target groups

1 About this document

The "Cutting machine ET9700" is consistently designated as machine in this Operation Manual.

This Operation Manual includes important notes on how you operate your machine/unit safely, properly and economically.

Use not in compliance with the intended purpose may result in hazard to the operator's health and life and/or in the risk of damage to/the machine/unit. Consequently, please only use the machine/unit

- in good order and condition,
- in accordance with its intended purpose,
- in a safety-conscious manner, with awareness of risks and hazards,
- in compliance with all notes included in this Operation Manual.

The machine/unit may only be operated by staff who

- has read the Operation Manual,
- has understood it,
- has been instructed in the operation of the machine/unit, and
- has signed in the Annex.



Figures may include accessories/options. Customer-specific equipment may vary.

The product images shown are for reference only and may differ from the product delivered.

1.1 Target groups

The target groups of this Operation Manual are:

Owner

An owner is a natural person or entity using the device himself/herself/itself, or on whose behalf the device is used. An owner may appoint a representative to exercise the owner's rights and obligations.

The owner has to make sure that

1 About this document

1.1 Target groups

- national provisions, occupational safety regulations and applicable environmental protection regulations are fully complied with;
- persons working on the machine/unit are adequately qualified;
- persons working on the machine/unit are suitable for operating the machine/unit;
- the Operation Manual has been read and understood. One hardcopy of the Operation Manual must always be kept at a designated place where the machine/unit is used.
- persons working on the machine/unit are aware of potential risks;
- the operating staff is familiar with the location as well as with operating the fire alarm and fighting means. Free access to this equipment must be ensured.
- personal protection equipment is worn (safety footwear, protection gloves and safety glasses).

Machine/unit fitters

Machine/unit fitters must be at least 18 years old and have completed training for the task, i.e. they must have attended a specialist vocational training.

A fitter

- must observe the instructions in the Operation Manual;
- must inform the owner on failures and damage.

Operator

An operator is a person charged with and instructed in the proper operation of the machine/unit by the owner or the otherwise contractually obliged person.

The operator

- must observe the instructions in the Operation Manual;
- must inform the owner on failures and damage.
- must not perform and maintenance or repair work on the machine/unit.

1 About this document

1.2 Storage

1.2 Storage

The Operation Manual is part of the machine/unit and must be kept near the machine/unit at all times. Upon disposal of the machine/unit, the Operation Manual must also be handed over.

1.3 Name plate

The name plate is fixed near the power cable.

1.4 Abbreviations

TM	cutting knife, plain
TMG	cutting knife, with slots
TMC	cutting knife, coated

2 Safety instructions

2.1 Presentation of warnings

Warning notes in the Operation Manual warn against risks involved with the handling of the machine/unit. Risk levels are identified as follows:

HAZARD!

The signal word HAZARD identifies an imminent hazard resulting in serious injuries or death. This warning is supplemented by a triangular hazard symbol.

WARNING!

The signal word WARNING identifies a potentially hazardous situation, which might result in serious injuries or death. This warning is supplemented by a triangular hazard symbol.

CAUTION!

The signal word CAUTION identifies a potentially hazardous situation, which might result in light injuries. This warning is supplemented by a triangular hazard symbol.

ATTENTION!

The signal word ATTENTION identifies a potentially hazardous situation, in which the product or property in the environment may be damaged. This warning is supplemented by a hazard symbol or an exclamation mark.

2 Safety instructions

2.2 Intended use

2.2 Intended use

This machine is intended for industrial use; it is only suitable for cutting pneumatic and hydraulic hoses up to a specific permissible diameter, see “Technical Data” in Section 3.

Intended purposes include:

- Single user workplace for one person only
- Manual input and retrieval
- Operating temperatures between 5 °C and 40 °C
- Operation in a closed operation room
- The machine must not be operated by persons not capable of operating the machine without any risk. These may include:
 - persons with physical or mental disabilities;
 - children and persons under age;
 - persons with a restricted capability for the operation of machines (e.g. under the influence of drugs, alcohol or narcotics)

Use of the control in compliance with the intended purpose also includes compliance with the instructions in this Operation Manual.

Use for other than the intended purpose

Any other use is considered as being not in compliance with the intended purpose, in particular:

- Design modifications of the machine
- Use in explosive environments
- Use of impermissible cutting knives
- Cutting of inflexible workpieces
- misuse of consumables and waste materials.

2 Safety instructions

2.3 Product-specific risks

WARNING!	
	<p>Risk for life and health!</p> <p>Use not in compliance with the intended purpose imposes risks for life and health. Consequences resulting from use for other than the intended purpose shall be under the sole responsibility of the owner.</p> <ul style="list-style-type: none">• Always use the machine in compliance with its intended purpose.

2.3 Product-specific risks

The machine/unit is designed in accordance with the latest state of technology. Nevertheless, the machine/unit may impose risks:

2.3.1 Risks imposed by mechanical equipment

Cutting risk

A cutting risk exists during cutting and when the cutting knives are replaced.

- Take care and wear cut-proof protective gloves when cutting and replacing knives.

Risk of squeezing

There is a risk of squeezing on the moving parts.

Tilting hazard

The risk of tilting mainly exists while the machine is being transported.

- Observe the machine's centre of gravity during transport.

2.3.2 Risks imposed by electricity

There is a risk of electrocution near the live parts!

- Work on electric systems may only be performed by qualified electricians or instructed and trained persons under the supervision of a qualified electrician.

2 Safety instructions

2.3 Product-specific risks

- Deactivate the machine/unit and secure it against unintentional restart before maintenance.

2.3.3 Risk imposed by pneumatic system

Risks are imposed by all pneumatic lines and connections. Pneumatic systems are subject to special safety provisions.

- After the machine is deactivated, the given and potentially hazardous residual energy has to be considered.
- Use correct hoses and hose clamps.
- Only work in the permissible pressure range.

2.3.4 Risks imposed by noise

The noise level meter acc. to IEC 804, Class 2, was calibrated before measuring.

The operation of the machine causes noise emissions of 90 dB(A) at the workplace. Noise protection is required.

Higher noise emissions may occur when other machinery is simultaneously used at the workplace. The machine owner must provide for appropriate protection, e.g.

- instruct staff to wear ear protection;
- provide information/instructions on risks
- identify hazardous areas
- provide health monitoring

2.3.5 Risks in case of fire

The operating staff has to be familiar with the location as well as with operating the fire alarm and fighting means. Free access to this equipment must be ensured.

Use extinguishing powder in case of fire.

2.4 Safety

2.4.1 Working area

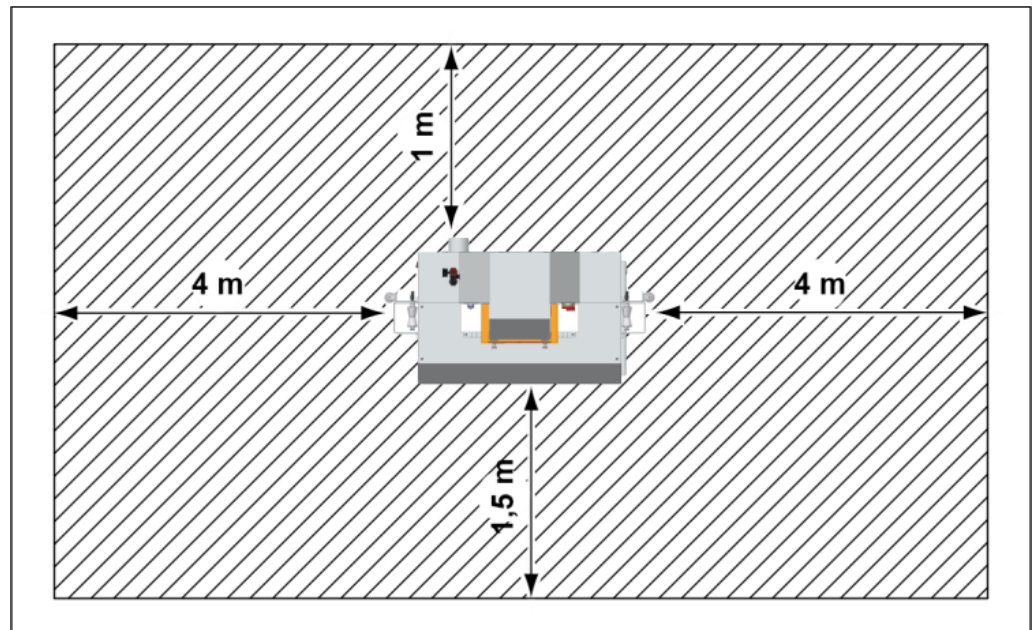

The working area is defined as the shaded area all around the machine (see illustration).





- Keep the working area free from trip hazards.
- Use ducts for lines and cables.
- Provide good illumination.

2 Safety instructions

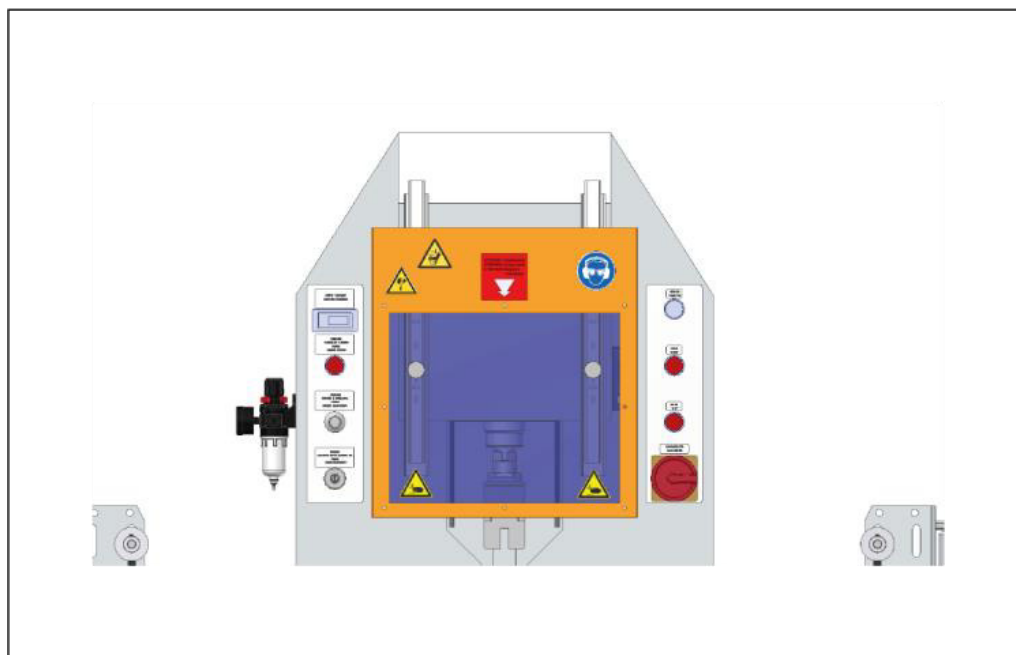
2.4 Safety

2.4.2 Warning signs on the machine



	Hand injury on the cover
	Crushing risk on the cover
	Cutting risk on the cutting knife
	Danger from electric current at the power supply line

2 Safety instructions

2.4 Safety

	<p>Risk of eye injuries Wear safety goggles</p>
	<p>Risk of hearing damage Wear ear protection</p>

Illegible or missing warning signs must immediately be replaced by the operator.

3 Machine description

3.1 Design and function

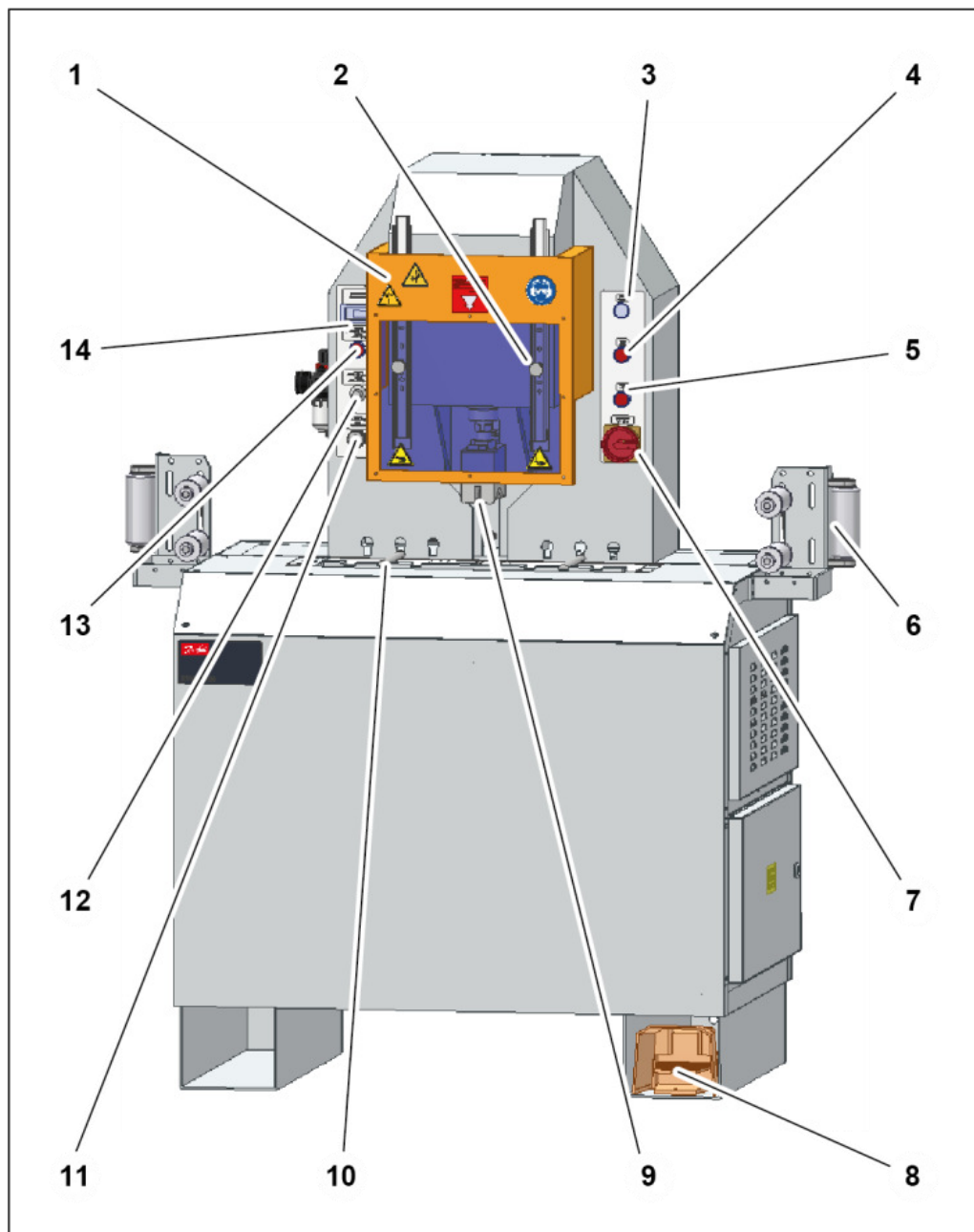

- (1) Protective cover
- (2) Catch bolt
- (3) Operation indicator lamp
- (4) MOTOR START button
- (5) MOTOR STOP button

3 Machine description

3.1 Design and function

- (6) Hose guide
- (7) Main switch
- (8) Foot pedal
- (9) Cutting fork
- (10) Bending pins
- (11) Speed setting
- (12) Return stroke setting
- (13) Return stroke, manual
- (14) Cut counter

The machine is switched on and off at the main switch (7). The operation indicator lamp lights up when the machine is switched on (3). The work piece is placed on the bending pins (10). Longer work pieces are also fed through the hose guide (6). Before the cutting process is started, the protective cover (1) is closed manually using the catch bolt (2). The motor of the cutting knife is started by means of the MOTOR START button (4). By pressing the foot pedal (8), the pneumatically driven cutting fork (9) moves to the lowest position and pushes the work piece towards the cutting knife for cutting. By releasing the foot pedal (8), the cutting fork (9) moves back up to the starting position. The motor of the cutting knife is stopped by means of the MOTOR STOP button (5).

The speed setting (11) is used to adapt the feed speed of the cutting fork (9) to the work piece. In order to optimise work processes, the return stroke setting (12) can be used to adapt the return stroke path of the cutting fork (8). Using the manual return stroke (13), the cutting fork (9) can be returned to the uppermost position manually, irrespective of the return stroke setting (12).

The cut counter (14) counts the number of completed cutting processes and can be reset by activating the pushbutton.

Accessories

The machine can be fitted with accessories. A list of the available accessories is included in the Annex, Section "Accessories".

3 Machine description

3.2 Technical data

3.2 Technical data

Machine

Dimensions L x W x H	1240 x 650 x 1650 mm
Weight	approx. 245 kg
Noise level	80 dB(A)
Protection class	IP 44
Operation mode	S6-60%

Function

Hose feed	Pneumatic
Brake motor	yes
Extraction connection	Ø 100 mm
Cutting knife Optional variant, see "Wear parts" in Section 9 Annex	TMC 520 x 4 x 40 mm
Cut counter:	yes
Feed force	7.6 kN (at 7 bar)

Work piece capacity

Workshop SAE R13 & SAE R15	3"
Production SAE R13 & SAE R15	2"
SAE R15	3"
Industry	3"
Max. outside	Ø 125 mm

3 Machine description

3.2 Technical data

Electrical connection

Power rating	7.5 kW
Voltage rating	400 V \pm 10 % 50 Hz, 3 phases (_00) 230 V \pm 10 % 60 Hz, 3 phases (_20)
Back-up fuse	400 V = 16 A (delayed) 230 V = 20 A (delayed)

Pneumatic connection

Power rating	7 bar
Air consumption	Approx. 25 NI / min*
Compressed air connection	Ø8mm (OD) snap-in pneumatic tube connector

Structural requirements

Permanent floor loading	Approx. 0.07 kg/mm ²
Floor carrying capacity	Min. 2500 kg/m ²
Floor quality	B25
Evenness	Max. unevenness 5 mm/m
Inclination	max. 5 mm/m

Ambient conditions

Ambient temperature	5 °C – 40 °C
Air humidity	45 % – 65 %

The * data are theoretical/computed values, or values measured on a prototype. Actual values may vary slightly, depending on the machine.

4 Transport and commissioning

4.1 Transport

4 Transport and commissioning

4.1 Transport

The goods should be transported in the original packaging. During transport, the goods must be secured safely within the packaging. All applicable laws and regulations relating to securing loads shall be observed during transport.

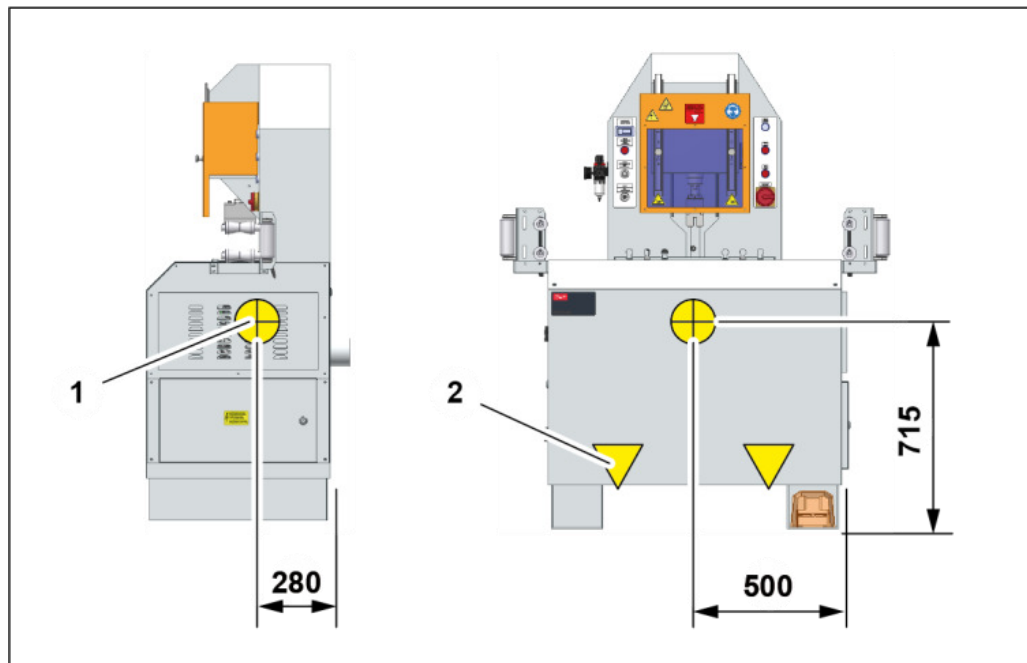

The machine/unit may only be unloaded and transported by means of a forklift, a lift truck or a crane. When a crane is used for transport, lifting gear with a sufficient length and lifting capacity has to be used. For machine/unit weight, please refer to "Technical data" in Section 3.

WARNING!



Danger from falling loads!

Risk of injury from falling loads.

- Do not stand under suspended loads.

4 Transport and commissioning

4.2 Intermediate storage of machine/unit

WARNING!



Danger from tilting machine/unit!

The machine/unit may tilt if it is transported improperly. There is a risk of being injured.

- Consider the machine/unit's centre of gravity (1).
- Only lift the machine/unit at the designated points.

1. Lift the machine/unit with a forklift, lift truck or crane at the designated points (2) and transfer it to the location of installation.

4.2 Intermediate storage of machine/unit

If the machine/unit cannot be mounted immediately upon delivery, it must be protected against:

- Contamination,
- Weather influences,
- Mechanical damage.

The machine/unit components may only be stored in closed rooms and under the following conditions:

- temperature between 10°C and 35°C,
- maximum air humidity 80% (non-condensating).

4.3 Commissioning

The machine is commissioned by the customer's fitter.

1. Place the machine on an even ground at the place of installation.

WARNING!



Danger from tilting machine!

If not bolted to the floor, the machine may tilt. There is a risk of being injured.

- Fix the machine on the floor.

2. Use suitable bolts to fix the machine legs on the floor.



Place the machine in a way so that it is easily accessible for maintenance work from all sides.

3. Check the machine for damage.
4. Check the electric cables for damage.
5. Train the operating staff and record training sessions in “Declaration of trained staff”, Section 9.

WARNING!



Risk of injuries!

Machine components might loosen during transport. Such components might be flung out during the cutting process. There is a risk of being injured.

- Perform a cutting process in idle mode and without a work piece.
- Check the machine for atypical noise.

4 Transport and commissioning

4.3 Commissioning

4.3.1 Extraction process for TM/TMG cutting knife

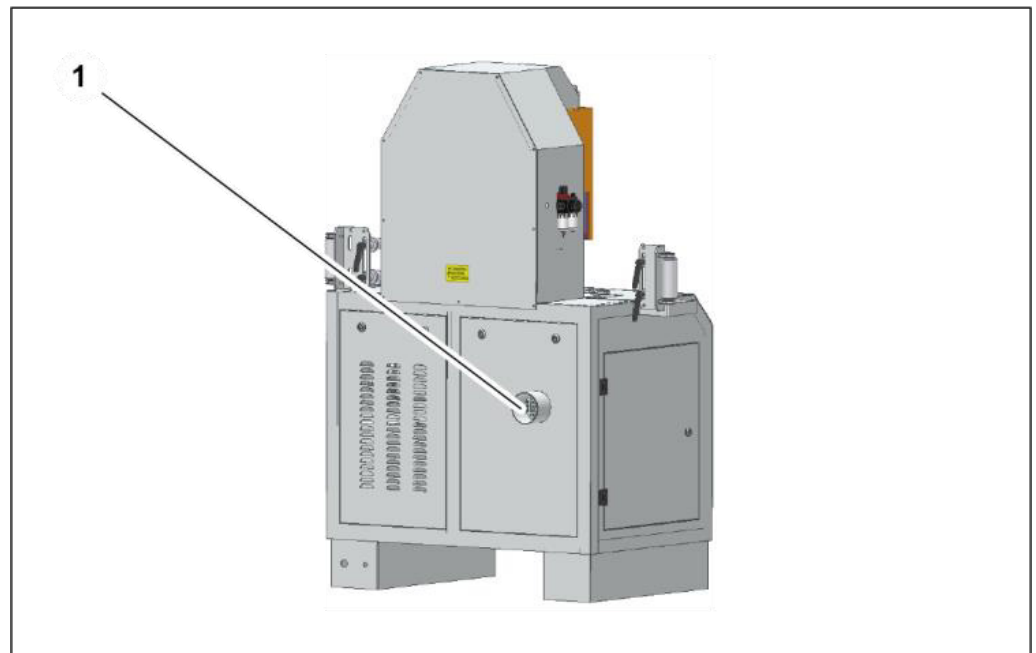

1. Mount a metal hose for smoke and particle extraction to the extraction nozzle (1).



We recommend an extraction fan with 100 mm water column and a capacity of 4 m³/min, as well as a filter element and a spark extinguisher suitable for this purpose.

4 Transport and commissioning

4.3 Commissioning

4.3.2 Extraction process for TMC cutting knife

WARNING!



Risk of fire

During cutting, there is a risk for life and health due to the fire hazard from flying sparks.

- Only operate the machine with a spark extinguisher.
- Clean the machine and spark extinguisher after each use (see “Cleaning” in Section 5).

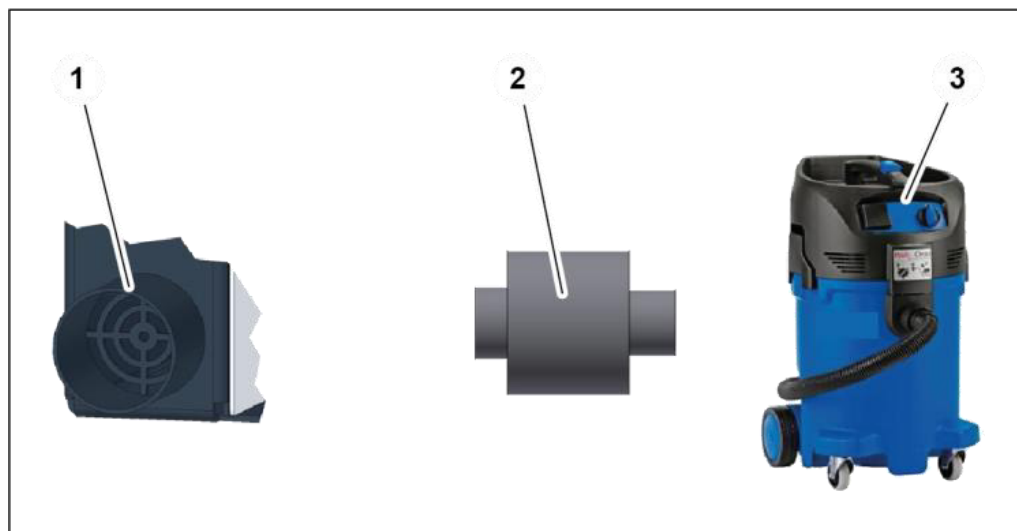

1. Attach the spark extinguisher (2) to the extraction nozzle (1) of the machine.
2. Attach the metal hose to the spark extinguisher (2) and extraction device (3).



We recommend an extraction fan with 100 mm water column and a capacity of 4 m³/min, as well as a filter element suitable for this purpose.

4 Transport and commissioning

4.3 Commissioning

4.3.3 Connection of compressed air

The compressed air connection must supply 7 – 8 bar.

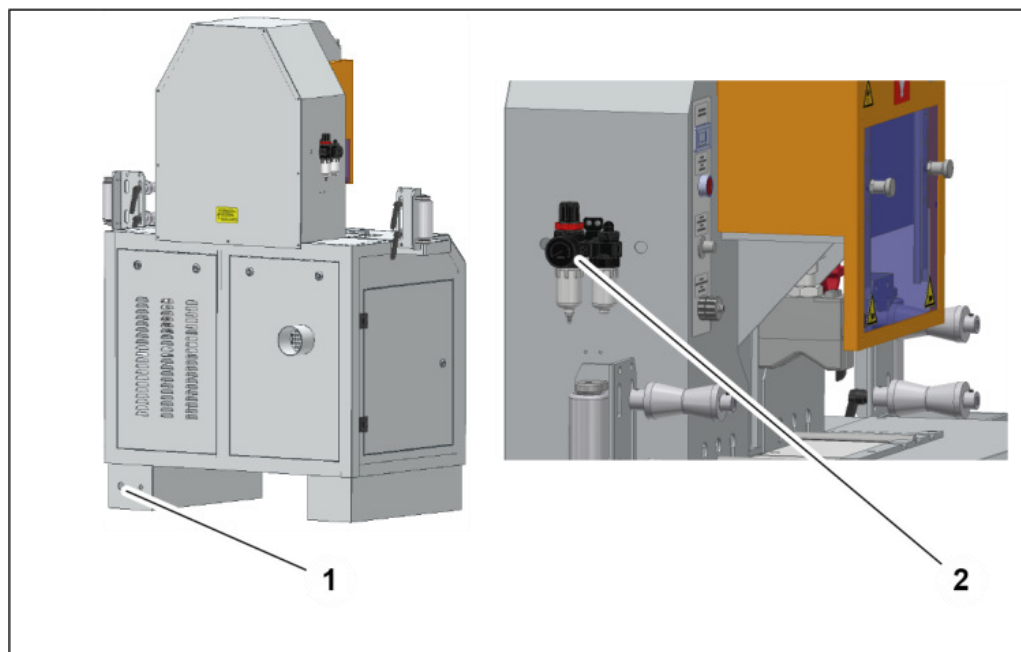

1. Establish the connection between the compressed-air system and the compressed-air connection (1) on the back of the machine.
2. Check the pressure at the compressed-air maintenance unit (2) and adjust to 7 bar if necessary.



The compressed air can be enriched with standard pneumatic oil through the oiler of the maintenance unit.

ATTENTION!



Damage to the machine

Contaminated air may cause damage to the cutting machine.

- Only use clean, and water-free compressed air.

4 Transport and commissioning

4.3 Commissioning

4.3.4 Electrical connection

WARNING!



Danger from electrical voltage!

There is a risk of electrocution near the live parts!

- Work on electric systems may only be performed by qualified electricians or instructed and trained persons under the supervision of a qualified electrician.
- Do not operate the machine without a sufficiently rated ground wire.
- Before performing maintenance work, switch off the machine and secure it against switching on unintentionally.

1. Switch off the power supply for the machine and secure it against switching on unintentionally.
2. Have the power cable of the machine connected to the local mains by a electrically qualified person according to the regulations of the Electricity Board.
3. Check the rotation direction of the electric motor. Exchange outer cable (phases) of the connection, if required.

ATTENTION!



Risk of damage to machinery!

Operating the motor in the wrong direction of rotation results in the loosening of the knife attachment.

- Ensure that the rotational direction of the motor is correct.
- If the motor has been operated in the incorrect direction of rotation, the securing nut and/or bolt has to be tightened as described in Section 6 “Replacing the knife”.

4 Transport and commissioning

4.3 Commissioning

Check rotational direction

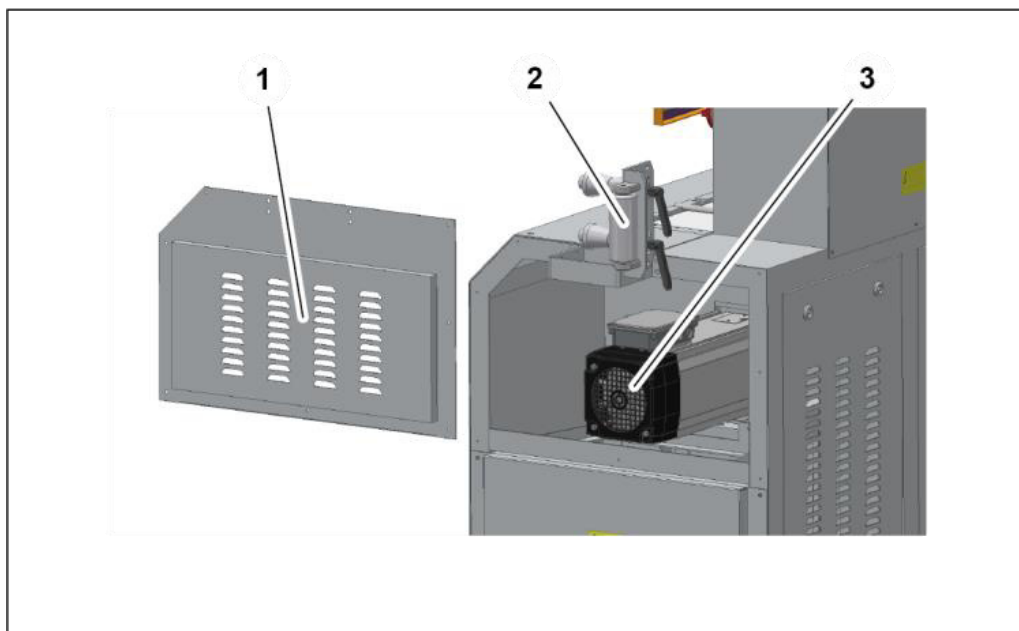

1. Remove the right-hand hose guide (2) from the machine.
2. Dismantle the right-hand, upper side cover (1).
3. Switch on the main switch.
4. Switch on the motor.
5. Switch off the motor.
6. While motor is coming to a standstill, check the direction of rotation from the fan wheel (3) of the motor.



When looking at the fan wheel, the fan wheel should be turning clockwise.

7. Switch off the main switch.
8. Attach the side cover (1).
9. Attach the hose guide (2).

5 Operation

5.1 What you have to observe

5 Operation

5.1 What you have to observe

The operator has received the Operation Manual from the owner, has read and understood it and will observe it.

Before starting and/or re-starting

- Ensure sufficient illumination of the working area of the machine.

During operation

- Observe the safety instructions on the machine.
- Make sure that no other persons stay in the working area.
- Each movement of the hand must be observed.
- Eating, drinking and smoking at the workplace is prohibited.
- Wear close-fitting clothes.
- Do not wear watches or jewellery.

5.2 Start

In order to switch on the machine, it must be connected to the power supply and compressed-air supply. After being switched on, the operation indicator lamp lights up and the machine is ready for operation.

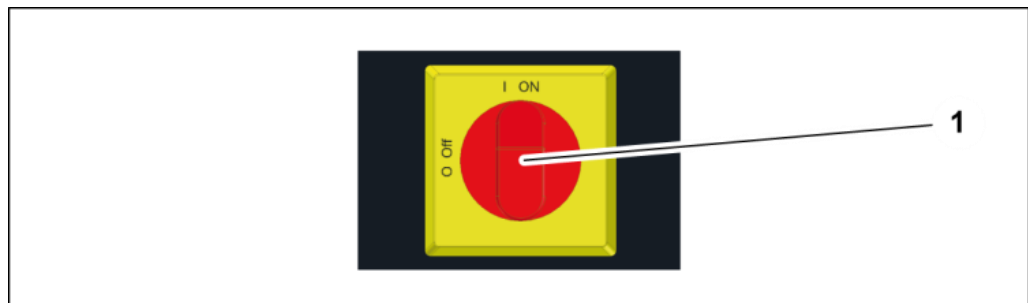

1. Make sure that the external compressed-air supply is switched on.
2. Activate the main switch (1).

5 Operation

5.3 Replacing the cutting fork

5.3 Replacing the cutting fork

The machine can be fitted with two different sizes of cutting fork. This allows the cutting fork to be adapted to the hose size.

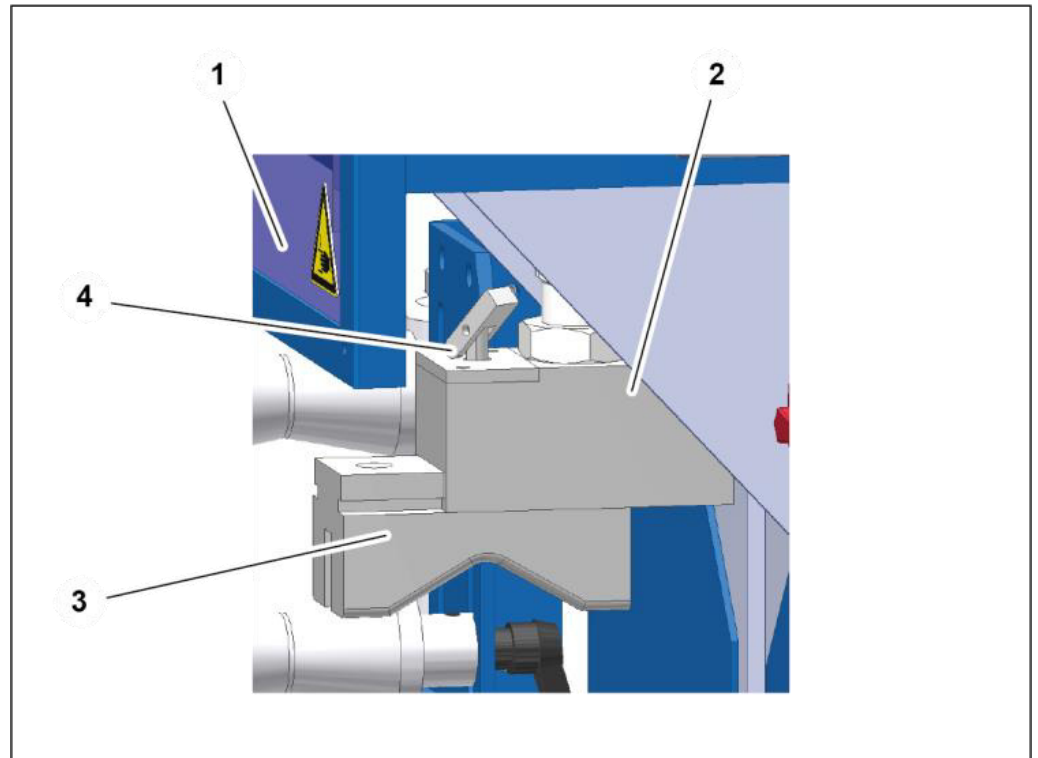

1. Switch off the main switch.
2. Open protective cover (1).
3. Release the quick fastener (4) by positioning it vertically.
4. Pull the cutting fork (3) out of the cutting fork holder (2).
5. Insert the desired cutting fork (3) into the cutting fork holder (2).
6. Lock the quick fastener (4).
7. Check that the cutting fork (3) is attached securely.

5.4 Workpiece cutting

5.4.1 Prerequisites

5 Operation

5.4 Workpiece cutting

ATTENTION!



Risk of damage to machinery!

The knife may be damaged when the machine is operated without work piece prestressing.

- Never cut without using the bending pins.
Exception:
3" work pieces are cut without the aid of bending pins.
- The bending pin and the hose have to be matched to each other.

Prerequisites for a correct cutting process:

- The bending pin position and the work piece diameter are matched to each other:
 - Large hose diameter = large distance
 - Small hose diameter = small distance
- The work piece must at least have the length of the minimum distance between the two bending pins.
- The work piece must fully be borne on the bending pins.

5 Operation

5.4 Workpiece cutting

5.4.2 Aligning the bending pins

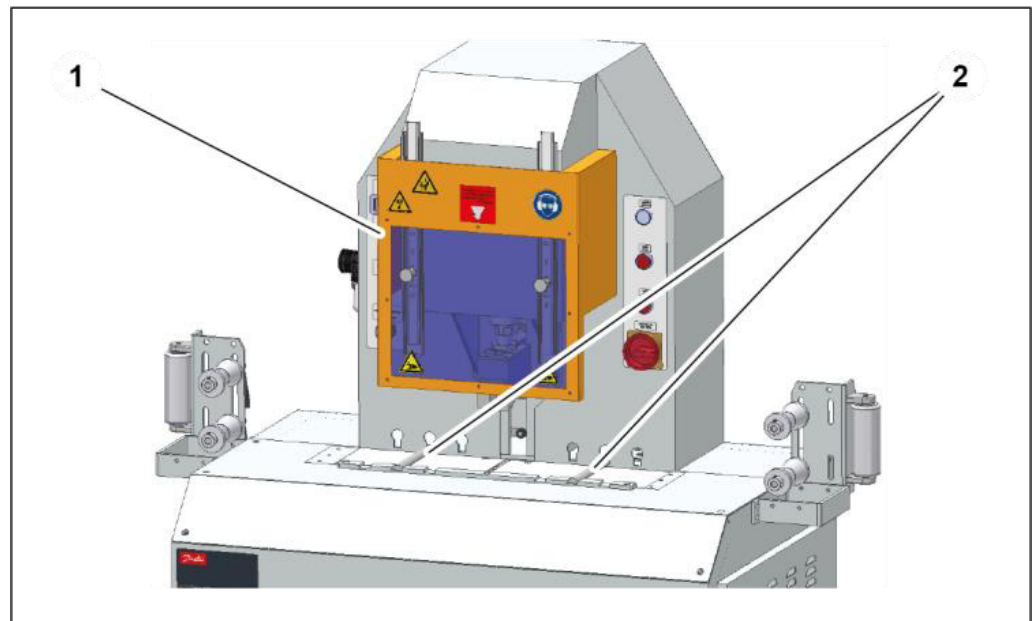

Work pieces up to 3"

1. Open protective cover (1).
2. Attach the bending pin (2) at the appropriate location.



- The bending pin position and the work piece diameter must be matched to each other:
- Large work piece diameter = large bending pin distance
- Small work piece diameter = small bending pin distance

3" work pieces

1. Open protective cover (1).
2. Remove the bending pins (2).

5 Operation

5.4 Workpiece cutting

5.4.3 Setting the cutting speed

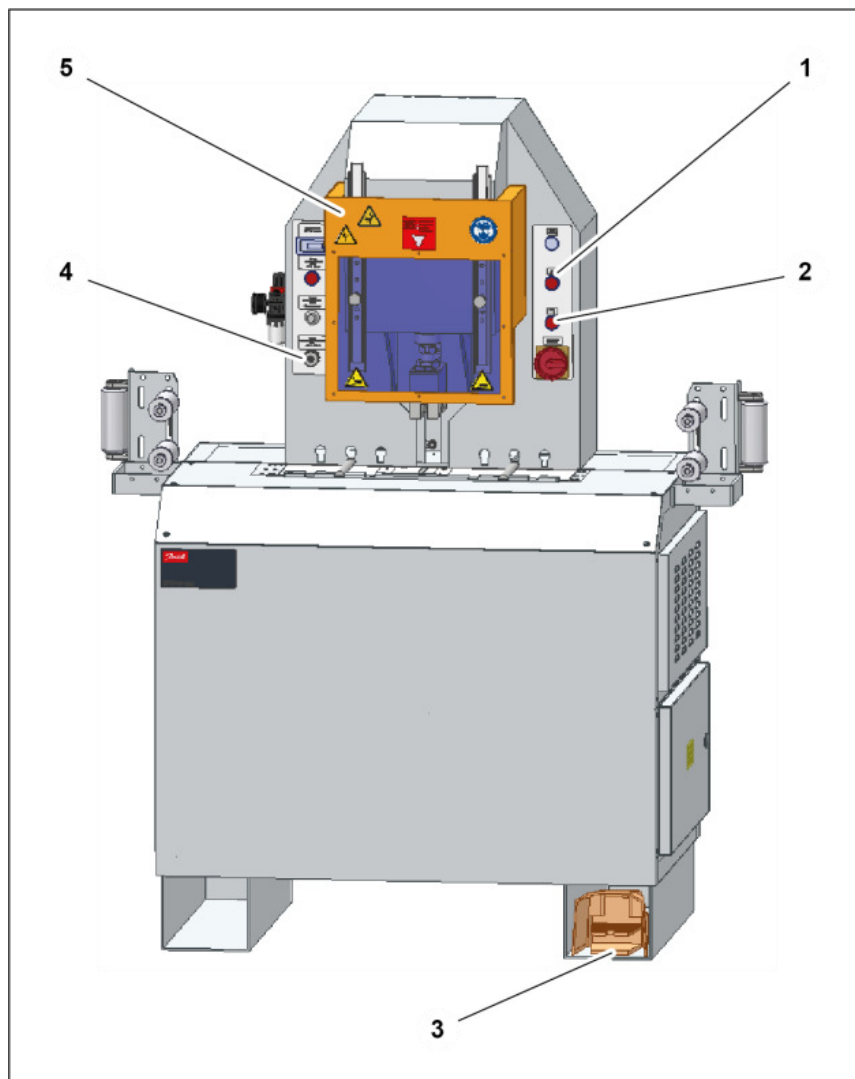

WARNING!



Cutting risk

There is a risk of cutting your extremities when cutting workpieces.

- Make sure that no extremities are in the working area behind the protective cover.

5 Operation

5.4 Workpiece cutting

1. Open protective cover (5).
2. Set the speed setting (4) to a medium value.
3. Insert the workpiece.
4. Close protective cover (5).
5. Start the motor (1).
6. Press the foot pedal (3) until the work piece has been cut.
7. Switch off the motor (2).

WARNING!



Cutting risk

Once the motor has been switched off, the cutting knife will continue to run for a short time during which there is still a risk of cutting your extremities.

- Only open the protective cover once the cutting knife has come to a complete standstill.

8. Open protective cover (5).
9. Remove the workpiece.
10. Check the cross section.
11. Adjust the speed setting (4) if necessary.
12. Repeat steps 3 – 11 until the cross section is as desired.

ATTENTION!



Risk of damage to machinery!

Operation with an excessive cutting speed will lead to increased wear of the cutting knife and may result in damage to the cutting knife, machine or work piece.

- Always adapt the cutting speed to the work piece diameter.



- Low speed 10 = large work piece diameter
- High speed 0 = small work piece diameter

5 Operation

5.4 Workpiece cutting

5.4.4 Setting the return stroke

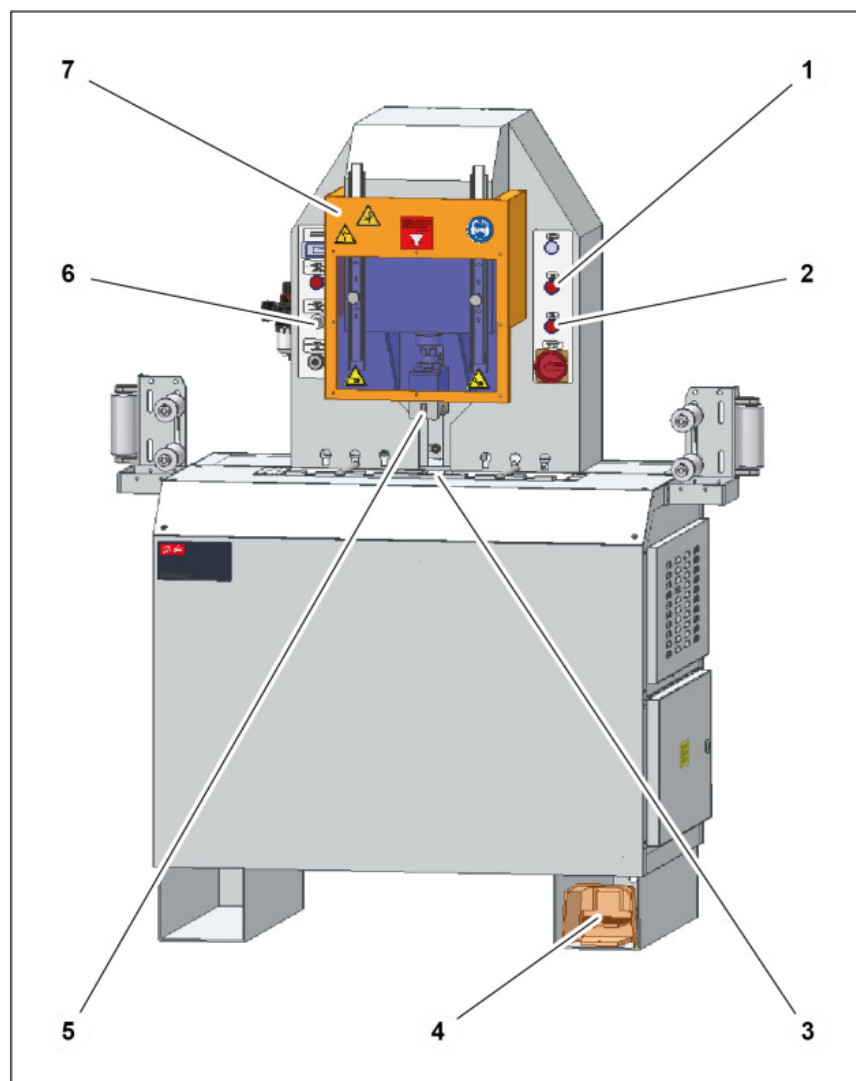

To enable quicker working processes, the return stroke setting can be used to adapt the return stroke path of the cutting fork to the work piece diameter.

WARNING!



Cutting risk

There is a risk of cutting your extremities when cutting workpieces.

- Make sure that no extremities are in the working area behind the protective cover.

1. Close protective cover (7).
2. Set the return stroke setting (6) to 0.

5 Operation

5.4 Workpiece cutting

3. Switch on the motor (1).
4. Press the foot pedal (4) until the cutting fork (5) has reached the lowest position.
5. Release the foot pedal (4).
6. Position the work piece on the side next to the cutting fork (5).
7. Check whether the opening between the cutting fork (5) and the cutting plate (3) is large enough for the work piece to pass through.
8. If necessary, increase the return stroke setting (6) in increments.
9. Repeat steps 4 – 7 until the opening is large enough.
10. Switch off the motor (2).

WARNING!



Cutting risk

Once the motor has been switched off, the cutting knife will continue to run for a short time during which there is still a risk of cutting your extremities.

- Only open the protective cover once the cutting knife has come to a complete standstill.

11. Open protective cover (7).
12. Remove the work piece.

5 Operation

5.4 Workpiece cutting

Manual return stroke

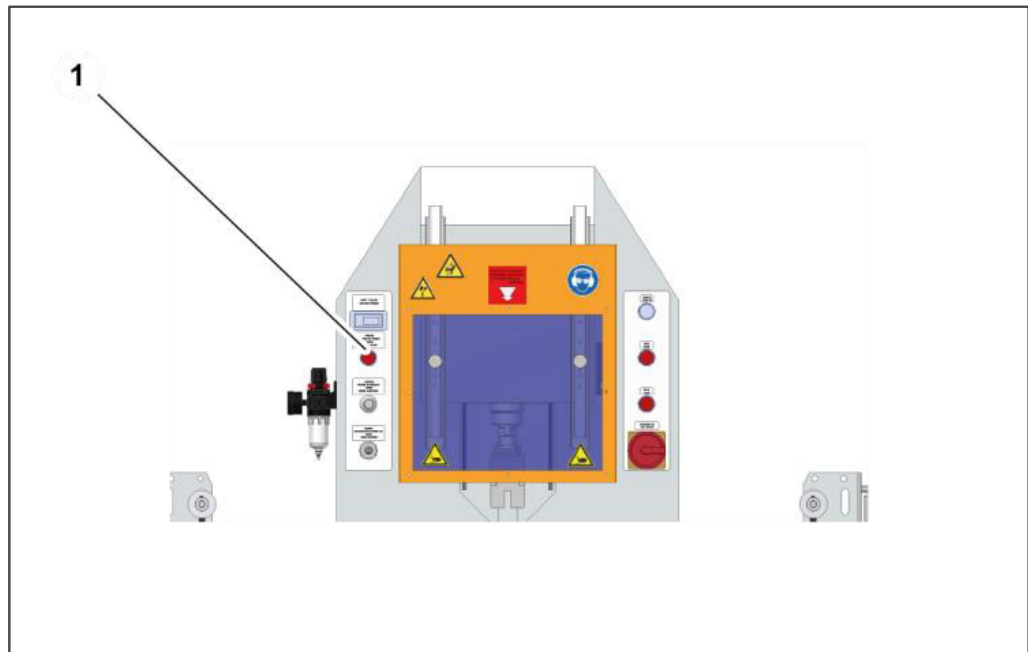

Using the manual return stroke (1), the cutting fork can be returned to the uppermost position manually, irrespective of the return stroke setting.

5.4.5 Cut counter

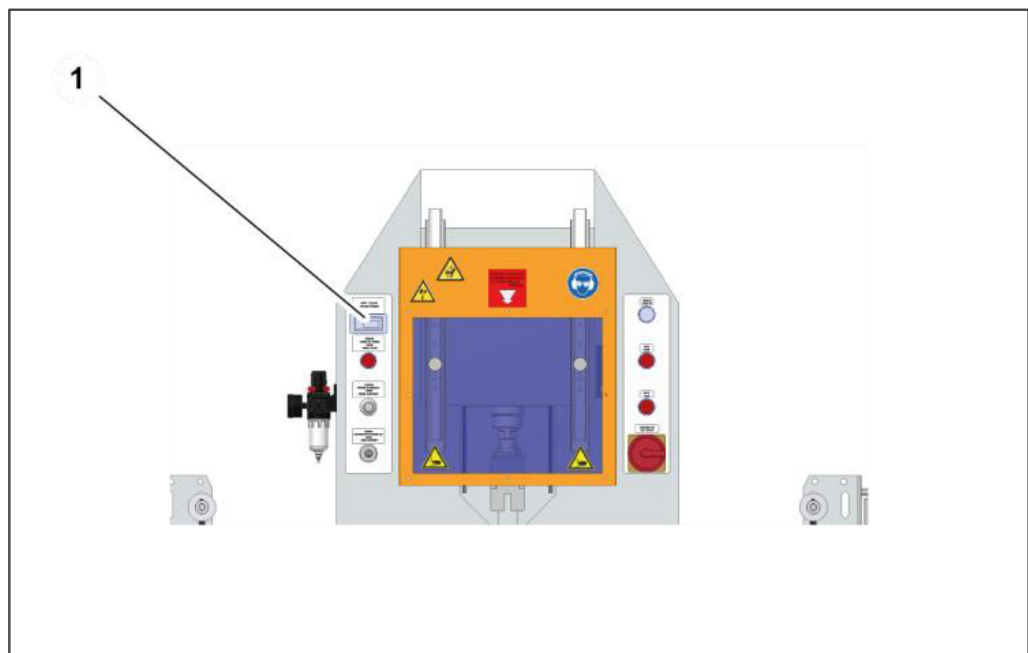

5 Operation

5.4 Workpiece cutting

The cut counter counts the cut once the lowest position of the cutting fork has been reached.

Pressing the RESET button resets the display to 0. Move the reset button to the lowest position in order to prevent it from being pressed unintentionally.

5.4.6 Individual cutting of work pieces

1. Insert the work piece and move it to the desired position. If necessary, secure the work piece using the guide rollers.
2. Close the protection cover.
3. Switch on the motor.
4. Press the foot pedal until the cutting fork has reached the lowest position and cut the work piece.
5. Release the foot pedal.
6. Wait until the cutting fork has moved back.
7. Switch off the motor.

WARNING!



Cutting risk

Once the motor has been switched off, the cutting knife will continue to run for a short time during which there is still a risk of cutting your extremities.

- Only open the protective cover once the cutting knife has come to a complete standstill.

8. Open the protection cover.
9. Remove the workpiece.

5 Operation

5.4 Workpiece cutting

5.4.7 Continuous cutting of work pieces

1. Insert the work piece and move it to the desired position. If necessary, secure the work piece using the hose guide.
2. Close the protection cover.
3. Switch on the motor.
4. Press the foot pedal until the cutting fork has reached the lowest position and cut the work piece.
5. Release the foot pedal.
6. Wait until the cutting fork has moved back.
7. Remove the cut work piece.
8. Feed in the remaining work piece and position as desired.
9. Repeat steps 4 – 8 for all work pieces.
10. Switch off the motor.

WARNING!



Cutting risk

Once the motor has been switched off, the cutting knife will continue to run for a short time during which there is still a risk of cutting your extremities.

- Only open the protective cover once the cutting knife has come to a complete standstill.

11. Open the protection cover.
12. Remove the workpiece.

5.5 Stop

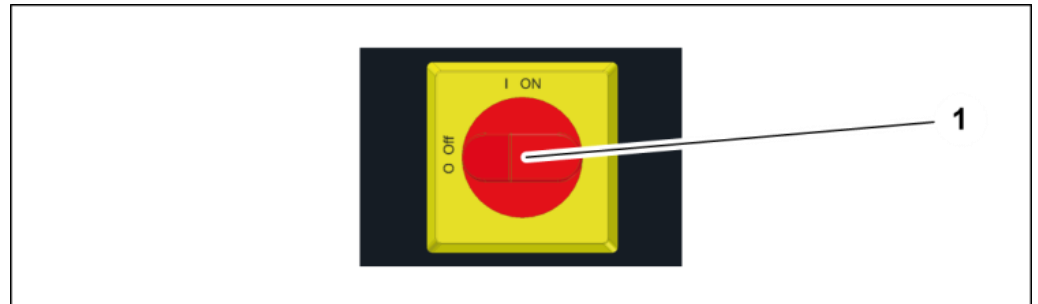

1. Complete the cutting process.
2. Deposit the work piece outside the machine.
3. Deactivate the main switch (1).
4. Check the machine for contamination and outside damage.
5. Check the cutting knife for damage and cracks.
6. Remove contamination, dust and chips using a vacuum.

WARNING!



Risk by bursting screens

Workpieces may penetrate porous screens, which may result in damage to the face and body.

- Check polycarbonate screens regularly and replace them at the specified intervals.



Polycarbonate screens are classified as wear parts by the Verein Deutscher Werkzeugmaschinenfabriken [German Machine Tool Builders' Association], since they lose their retention capacity due to environmental effects. Polycarbonate screens have to be replaced 5 years after the construction of the machine (see year of construction) at the latest.



Inform the fitter in case of damage or other irregularities.

5.6 Overload protection

The motor is protected against overload by a motor protection switch.

After a motor overload, if any, let the motor cool down and restart it.

The restart protection prevents an unintentional restart of the machine. Starting the machine is only possible by activating the main power switch again.

5.7 Cleaning

WARNING!



Risk for life and health!

There is an acute risk of injuries when working in the danger zone of the cutting knife.

- Disconnect the machine from all energy sources and secure it against switching on unintentionally.
- Wear cut-proof gloves.

ATTENTION!



Risk of damage to machinery!

If the machine is cleaned with a steam jet or compressed air, dirt and water may ingress in the machine and cause serious damage.

- Do not use a steam jet to clean the machine.
- Do not use compressed air to clean the machine.

1. Use a vacuum cleaner or a soft cloth to clean the machine.
2. Empty the dust collection trays and clean the maintenance compartment of the cutting knife.
3. Clean the extraction line.

6 Maintenance

6.1 What you have to observe

6 Maintenance

Regular maintenance will ensure the continuous operation reliability of the device.

6.1 What you have to observe

This Section describes action to be taken by you as the fitter regularly to ensure the troublefree use of the machine/unit.

- Maintenance work may only be performed by qualified maintenance staff (machine/unit fitters).
- Repair work on the machine/unit or components may only be performed by appropriately qualified expert staff or UNIFLEX experts!
- The machine/unit must always be deactivated during maintenance work (see "Deactivation" in Section 5). Use the lock to prevent the main switch from being switched on and also attach a sign. Example text:

Machine/unit out of service for
maintenance work!
Do not switch on!

- Welding, flame-cutting and grinding work on and in the machine/unit and its environment must be approved in advance. There is a risk of fire. The machine/unit must be cleaned from dust and inflammable substances. Adequate ventilation must be ensured.

6.2 Maintenance schedule

If not specified otherwise, inspections listed in the maintenance schedule are visual inspection. Replace defective parts.

If you work in 2 shifts, the check frequency has to be doubled. If you work in 3 shifts, you proceed as with 2-shift operation.

Record maintenance work performed in the maintenance log.

6 Maintenance

6.2 Maintenance schedule

Maintenance item	Weekly	Monthly	Number of years
Cutting tool			
Cutting knife: check cutting edge for sharpness, cracks and breakouts, check for changes in colour, sharpen or replace knives as appropriate. Coating: check (TMC cutting knives only).	X		
Bolted connections: check and retighten if necessary.		X	
Machine: Cleaning		X	
Extraction line: Cleaning		X	
Safety equipment			
Knife protection: check for function Open the protection cover. Wearing cutting protection gloves, press the knife protection down on the outside edges with both thumbs. There must be a significant resistance.	X		
Protective cover: check for function Close the protection cover. Switch on the main switch. The operation indicator lamp lights up. Start the motor. Lift the protective cover. The machine must switch off immediately.	X		
Warning signs on the machine: Check legibility (see "Warning signs on the machine" in Section 2).		X	
Motor brake: Motor: check for function and readjust if necessary (see "Motor brake readjustment", Section 6).		X	
Protective screens: clean using a household window cleaner.	X		
Protective screens: replace no later than five years after manufacture (see year of construction).			5



The replacement of wear parts must be recorded in the maintenance log!

6 Maintenance

6.3 Replacing the cutting knife

6.3 Replacing the cutting knife

WARNING!



Cutting risk!

Replacing the cutting knife imposes a significant risk of injuries to the hands.

- Always wear cut-proof gloves when replacing the knives.

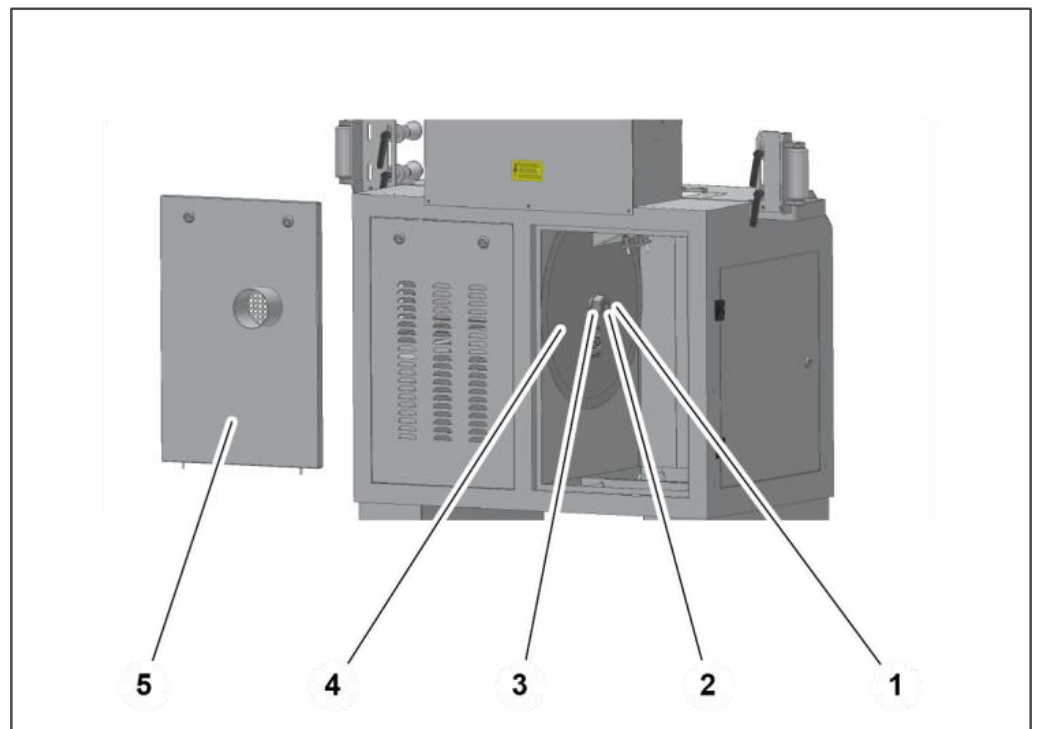

1. Complete the cutting process.
2. Deposit the workpiece outside the machine.
3. Disconnect the machine from the electrical and pneumatic supply.
4. Use a control cabinet key to open the rear maintenance door (5) and lift it out.
5. Hold the shaft (3) with a hexagon socket wrench and release the nut (1) using an open-end wrench.
6. Remove the washer (2) and cutting knife (4) from the shaft (3) and place them down carefully.
7. Assemble the new cutting knife (4).

6 Maintenance

6.3 Replacing the cutting knife

ATTENTION!



Risk of damage to machinery!

If the directions of rotation of the motor and the cutting knife do not match, there is a risk that the cutting knife will be destroyed during cutting.

- Check the direction of rotation before switching on



Observe the cutting direction!

The direction of rotation is to the left when viewing the free end of the shaft.

8. Insert the washer (2) and tighten the nut (1).
9. Reinsert the maintenance door (5) and close it.

6 Maintenance

6.3 Replacing the cutting knife

6.3.1 Replacing a resharpened cutting knife

1. Replacing the cutting knife (see “Replacing the cutting knife” in Section 6)



If the outside diameter of the resharpened cutting knife is ≤ 515 mm, the height of the motor must be adapted to the outside diameter of the cutting knife.

It is recommended not to use cutting knives with a diameter smaller than ≤ 515 mm.

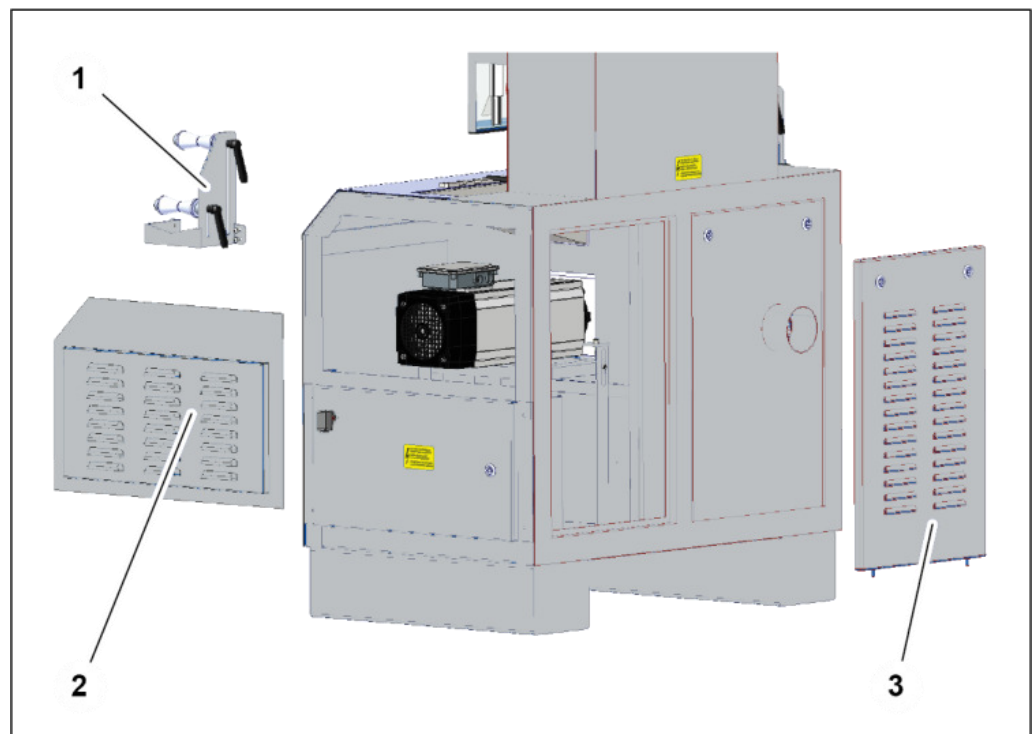

2. Open the motor maintenance door (3) and lift it out.
3. Remove the right-hand hose guide (1) from the machine.
4. Dismantle the right-hand, upper side cover (2).

6 Maintenance

6.3 Replacing the cutting knife

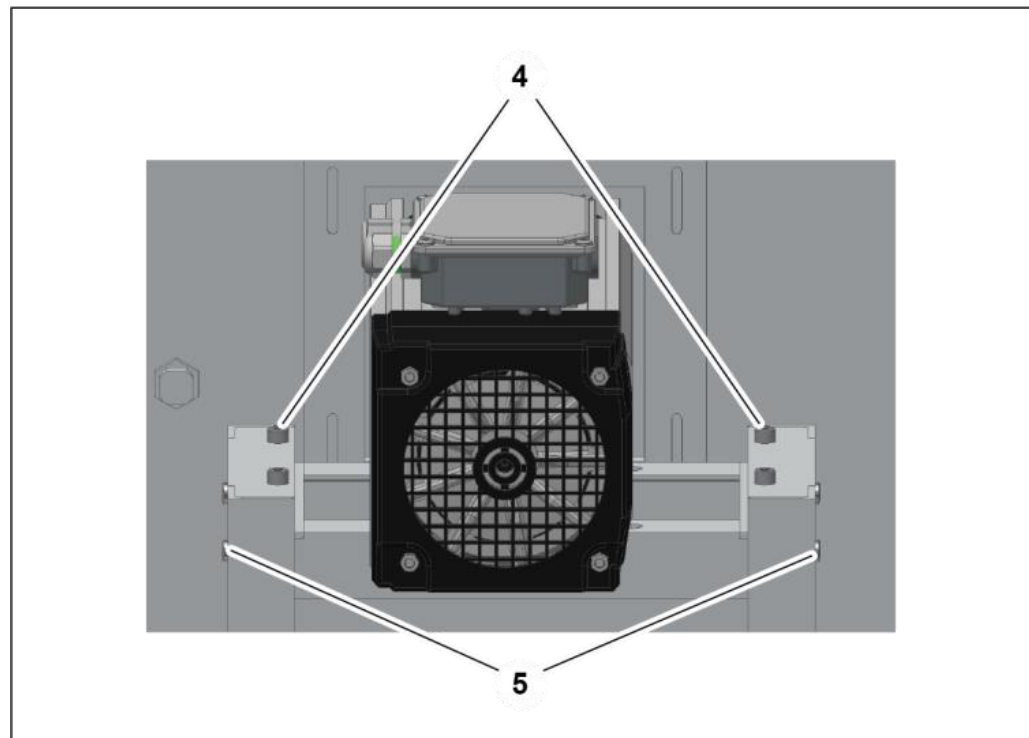

5. Release the four locking screws (5).

WARNING!



Cutting risk!

If the position of the cutting knife is set too high, the result will be insufficient protection and a significant risk of injuries to the hands.

- There must always be a safety distance of at least 20 mm between the cutting knife and the knife protection.

6 Maintenance

6.3 Replacing the cutting knife

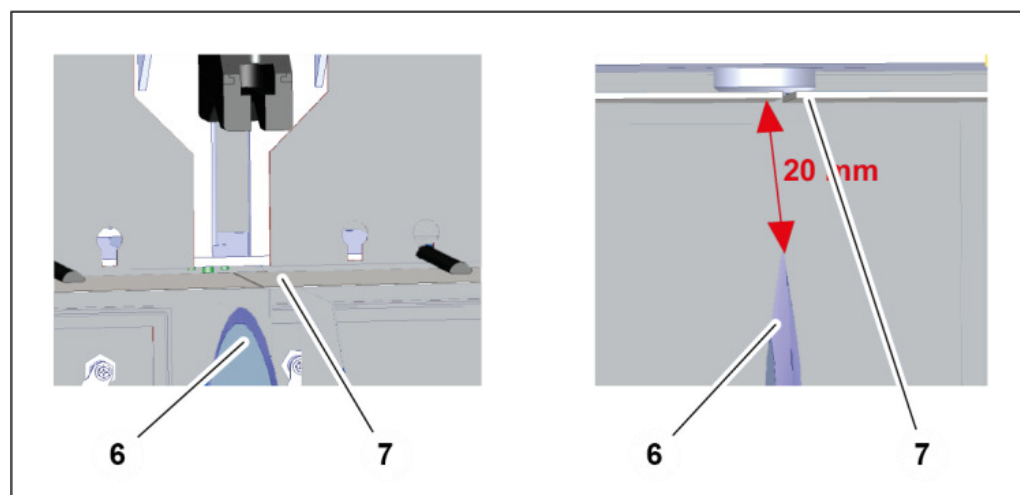

6. Adjust the height using the height adjustment screws (6). The distance between the cutting knife (6) and the knife protection (7) must be 20 mm.

ATTENTION!



Risk of damage to machinery!

If the cutting knife is at an angle, this will result in damage to the cutting knife and machine.

- Make sure that all four height adjustment screws are equally adjusted.
- Check that the cutting knife is straight.

7. Tighten the locking screws (5).
8. Use a suitable measuring aid to check the adjusted height. The distance between the cutting knife (6) and the knife protection (7) must be 20 mm.
9. Check that the cutting knife is straight.
10. Attach the side cover (2).
11. Attach the hose guide (1).
12. Insert the motor maintenance door (3) and close it.

6 Maintenance

6.3 Replacing the cutting knife

ATTENTION!



Risk of damage to machinery!

If the outside diameter is set incorrectly, this will result in damage to the cutting knife and machine.

- If a new cutting knife is assembled, the height of the motor also has to be readjusted.

6.4 Checking the motor brake

Due to wear on the brake linings, the braking effect of the motor brake may decrease over time.

In this case the motor brake has to be readjusted.

WARNING!



Risk of injuries

The motor brake is a major safety element of the machine. For this reason, the machine must in no event be operated without any functional motor brake and only with mounted fan runner cover.

- Have the motor checked and readjusted regularly.
- Do not continue using the machine if the motor brake is defective.

1. Switch on the motor.
2. Once the motor has reached full speed, allow the motor to run for a further 30 seconds.
3. Switch off the motor and measure the time taken for the motor to come to a complete standstill.
4. Check that the motor comes to a complete standstill within 10 seconds of being switched off. Otherwise readjust the motor brake!



The motor brake must bring the motor to a standstill within 10 seconds of it being switched off. If this time is exceeded, the motor brake must be readjusted!

6.5 Motor brake readjustment

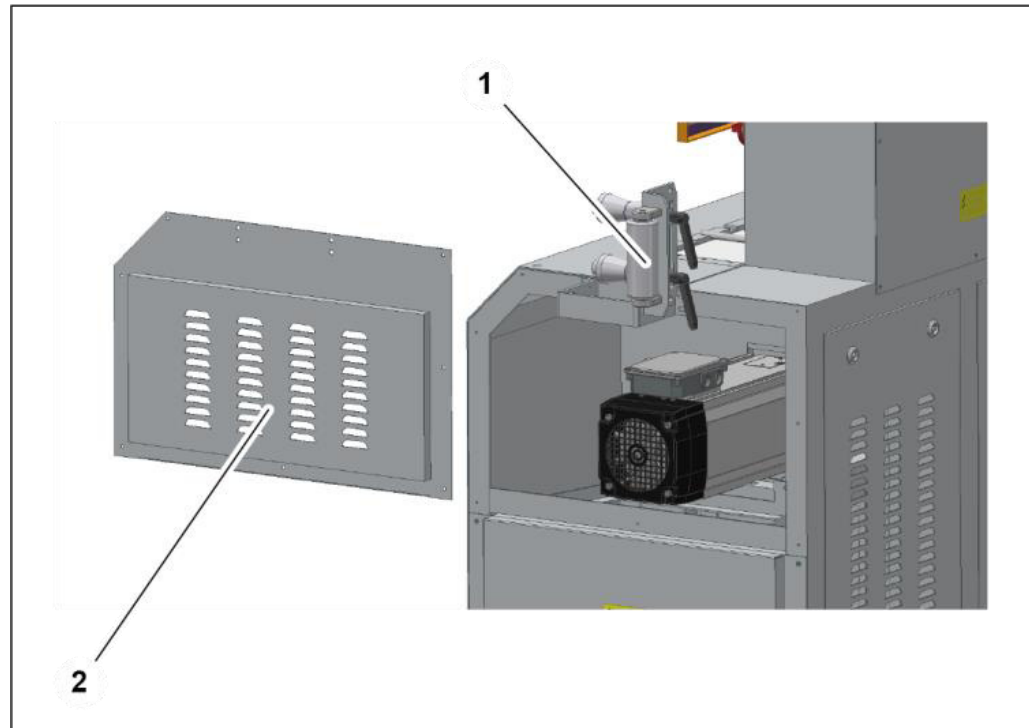

1. Switch off the machine and secure it against switching on unintentionally.
2. Dismantle the right-hand hose guide (1).
3. Dismantle the right-hand, upper side cover (2).
4. Adjust the motor brake according to the motor variant (see “Motor brake variants” in Section 6).
5. Assemble the side cover (2) and hose guide (1) in reverse order.

6.5.1 Motor brake variants

The motor installed in the machine may vary in terms of the design. The adjustment of the motor brake is described below for each variant.

6 Maintenance

6.5 Motor brake readjustment

WARNING!



Hot surface - risk of burns

The motor brake can become very hot. There is a risk of burns if this part is touched.

- Do not touch parts of the motor without sufficient protection.

WARNING!



Risk of injuries

The fan wheel imposes a risk of serious injuries.

- Only switch on the motor when the fan wheel cover is mounted.



If problems still occur once the motor brake has been readjusted, contact the UNIFLEX service immediately:
Tel. +49 (0) 6039 9171-0

Motor brake with adjusting screw

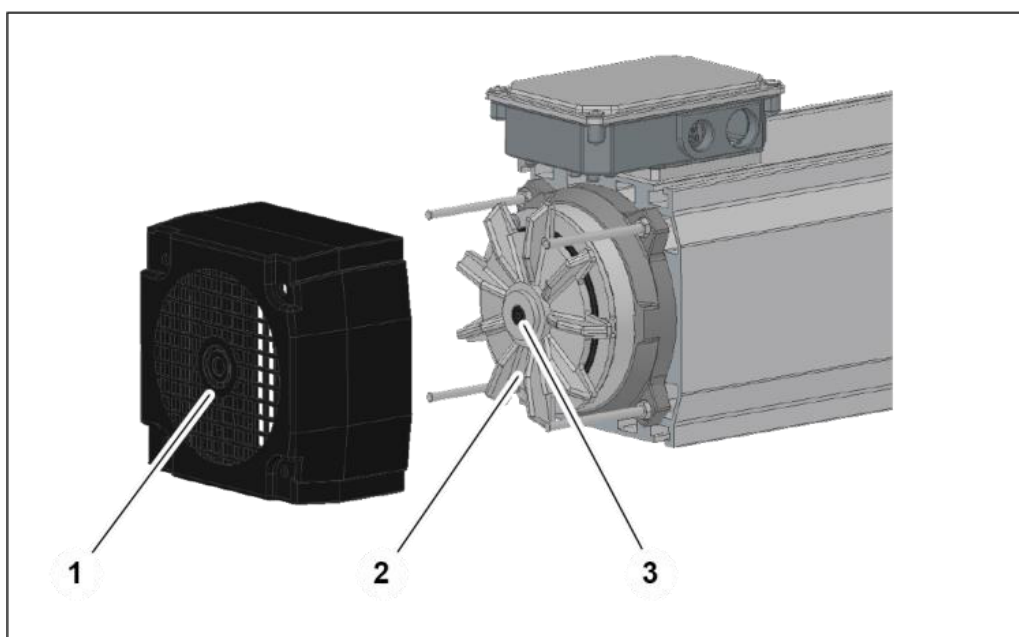

1. Remove the fan wheel cover (1).

6 Maintenance

6.5 Motor brake readjustment

2. Secure the fan wheel (2) with a suitable tool.
3. Use a hexagon socket wrench to turn the adjusting screw (3) clockwise by approx. 30° ($30^\circ = 0.1 \text{ mm}$).
4. Attach the fan wheel cover.
5. Switch on the motor.
6. Once the motor has reached full speed, allow the motor to run for a further 30 seconds.
7. Switch off the motor and measure the time taken for the motor to come to a complete standstill.

ATTENTION!



Risk of damage to machinery

If the motor brake adjustment is too tight, this will result in increased wear and high heat generation.

- Check that the time taken for the motor to come to a standstill is between 9 – 10 seconds.

8. Check the time taken for the motor to come to a standstill.
> 10 seconds, retighten the adjusting screw (3).
< 9 seconds, loosen the adjusting screw (3) slightly.

Motor brake with adjusting nut

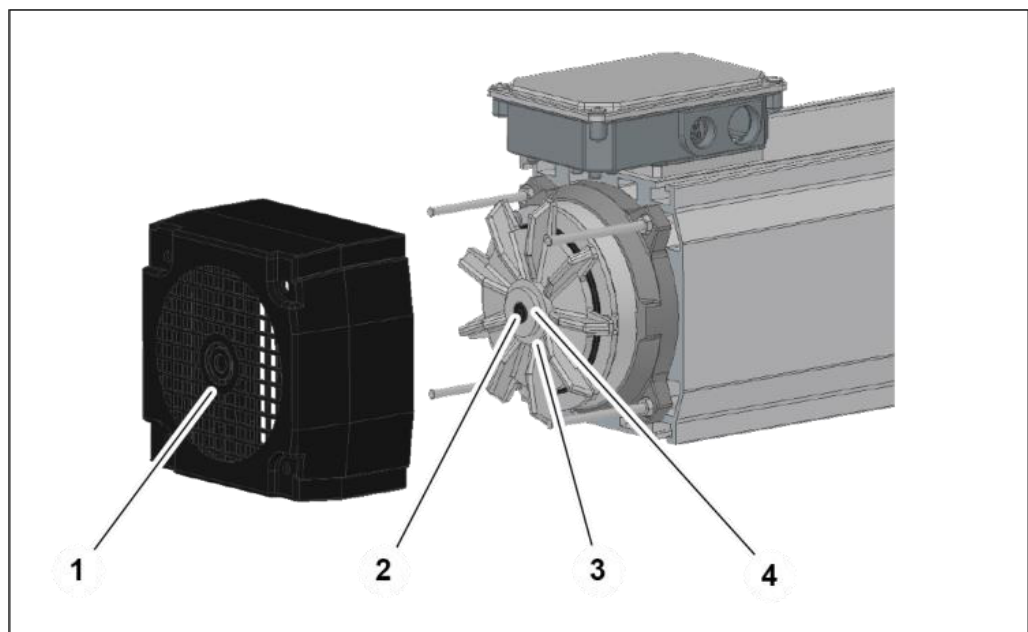

6 Maintenance

6.5 Motor brake readjustment

1. Remove the fan wheel cover (1).
2. Bend up the locking washer (3) of the adjusting nut (4).
3. Secure the shaft (2) using a hexagon socket wrench.
4. Use an open-end wrench to turn the adjusting nut (4) clockwise by approx. 30° (30° = 0.1 mm).
5. Lock the adjusting nut (4) with the locking washer (3).
6. Attach the fan wheel cover (1).
7. Switch on the motor.
8. Once the motor has reached full speed, allow the motor to run for a further 30 seconds.
9. Switch off the motor and measure the time taken for the motor to come to a complete standstill.

ATTENTION!



Risk of damage to machinery

If the motor brake adjustment is too tight, this will result in increased wear and high heat generation.



- Check that the time taken for the motor to come to a standstill is between 9 – 10 seconds.

10. Check the time taken for the motor to come to a standstill.
> 10 seconds, retighten the adjusting nut (4).
< 9 seconds, loosen the adjusting nut (4) slightly.

7 Troubleshooting

Error	Cause	Remedy
Machine does not cut	Switch "OFF"	Activate switch
	Power plug defective	Check power plug and replace, if required
	Motor defective	Contact Service desk
	Cutting knife worn	Check cutting knife for wear and replace, if required
Knife not centred	Flange disc is not positioned correctly on the feather key	Turn flange disc and insert it into the feather key.

8 Decommissioning, disposal

WARNING!	
	<p>Risk by electrical voltage!</p> <p>There is a risk of electrocution near the live parts!</p> <ul style="list-style-type: none">• Shut down the machine/unit.• Disconnect the machine/unit from the power supply.
CAUTION!	
	<p>Risk of injuries!</p> <p>Contact with consumables, e.g. oils, greases, test media, imposes a risk of injuries for the skin, eyes, respiratory and intestinal tracts!</p> <ul style="list-style-type: none">• Observe supplier's protection and safety instructions (see data sheet).• Wear personal protection equipment.• Do not eat, drink or smoke in the working area and when handling consumables.• Ensure good ventilation.

8.1 Dismantling

This section describes activities to be performed by you as the operator to ensure the safe dismantling of the machine/unit.

- The machine/unit may only be dismantled by entrusted and qualified staff.
- Check the machine/unit for mechanical tension and consider it during dismantling.

8.2 Recycling

The machine/unit contains metal, hydraulic hoses, electric cables and electronic components, depending on the type.

As regards disposal, the applicable national environmental protection and waste disposal regulations have to be complied with.

8.3 Consumables and waste

Observe applicable national environmental protection and waste disposal regulations.

Return consumables, e.g. oils, greases, test media, to supplier - they are hazardous waste. Also observe the information given on the safety data sheet.

9 Annex



Individual machine/unit components may deviate in their features. Please indicate the serial number of the machine for spare part orders.

9.1 Accessories (retrofittable)

Accessories	Part code
Hose length measuring device	UMS 4
Hose guide, 2000mm	UHG 14
Extension, 1000mm	UHG 14 EXT
Suction system + Adaptor	UVC S36 + 777.061
Spark extinguisher	330.2
Cutting knife with inclined slots	TM G 520x4x40
Cutting knife	TM 520x4/5x40 CL
Hose coiling reel with variable-speed drive	UWT 2.2
Hose winder for hydraulic hoses up to 1¼"	UAT 4.2
Hose winder with 5 hose cages	USH 4-5
Suction filter system	UVC 100.2 MVA FSD

Please contact our Sales department for ordering accessories.

9.2 Spare parts list

9.2.1 Mechanical equipment

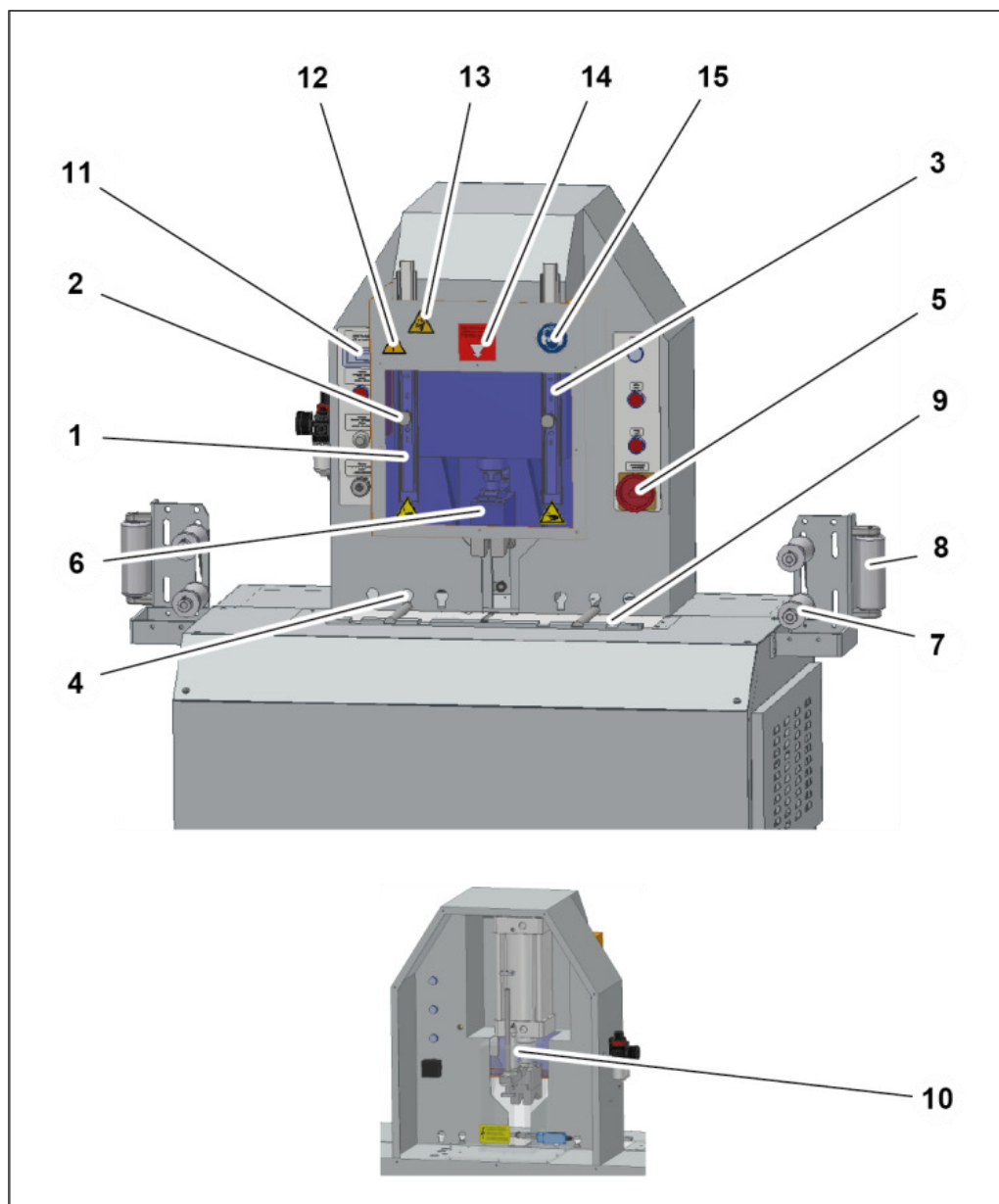

Item	Quantity	Part code	Designation
1	1	PJ_GLS1050	Front protective screen
2	2	501.071	Catch bolt
3	2	PJ_10.0410.04	Telescopic rail
4	1 set	UJ_70.0410.15	Bending pins (1 set = 2 pins)

9 Annex

9.2 Spare parts list

Item	Quantity	Part code	Designation
5	1	UJ_20.30.171	Main power switch
6	1	UJ_70.0410.09	Hold-down, small nominal widths
	1	UJ_70.0410.08	Hold-down, large nominal widths
7	4	UJ_70.0410.23	Guide roller horizontal
8	2	UJ_70.0410.13	Guide roller vertical
9	1	UJ_70.0410.11	Protective plate cutting knife(1 set = 2 pins)
10	1	UJ_30.10:01	Oil pressure spring
11	1	888.140	Digital counter
12	2	715.4	Squeezing risk warning sign
13	2	716.4	Hand injuries warning sign
14	1	304.101.4	Mandatory sticker
15	1	3127/60	Mandatory sticker

9 Annex

9.2 Spare parts list

9.2.2 Pneumatic

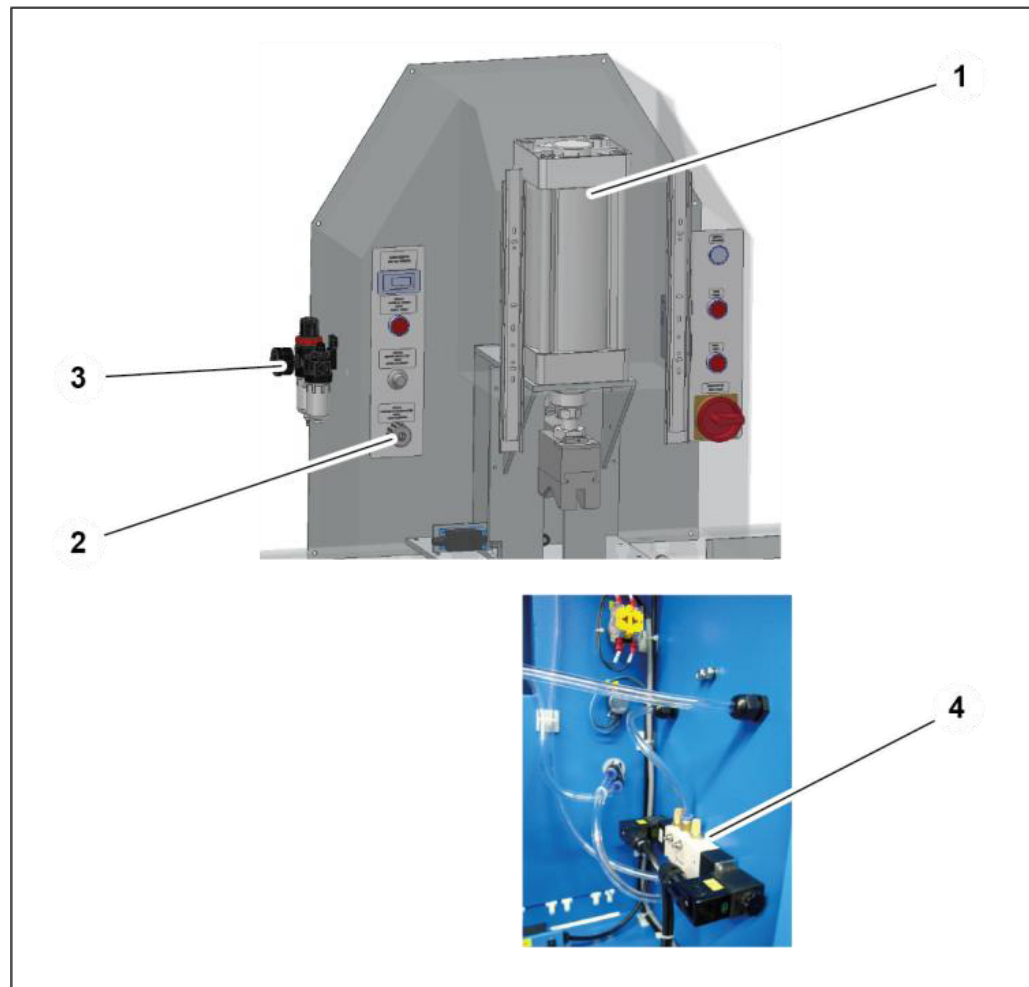

Item	Quantity	Part code	Designation
1	1	PJ_40.10:05	Pneumatic cylinder
2	1	305.070	Throttle valve
3	1	UJ_40.50.02	Compressed-air maintenance unit
4	1	UJ_40.50.19	5/3-way pneumatic valve

9 Annex

9.2 Spare parts list

9.2.3 Electric equipment

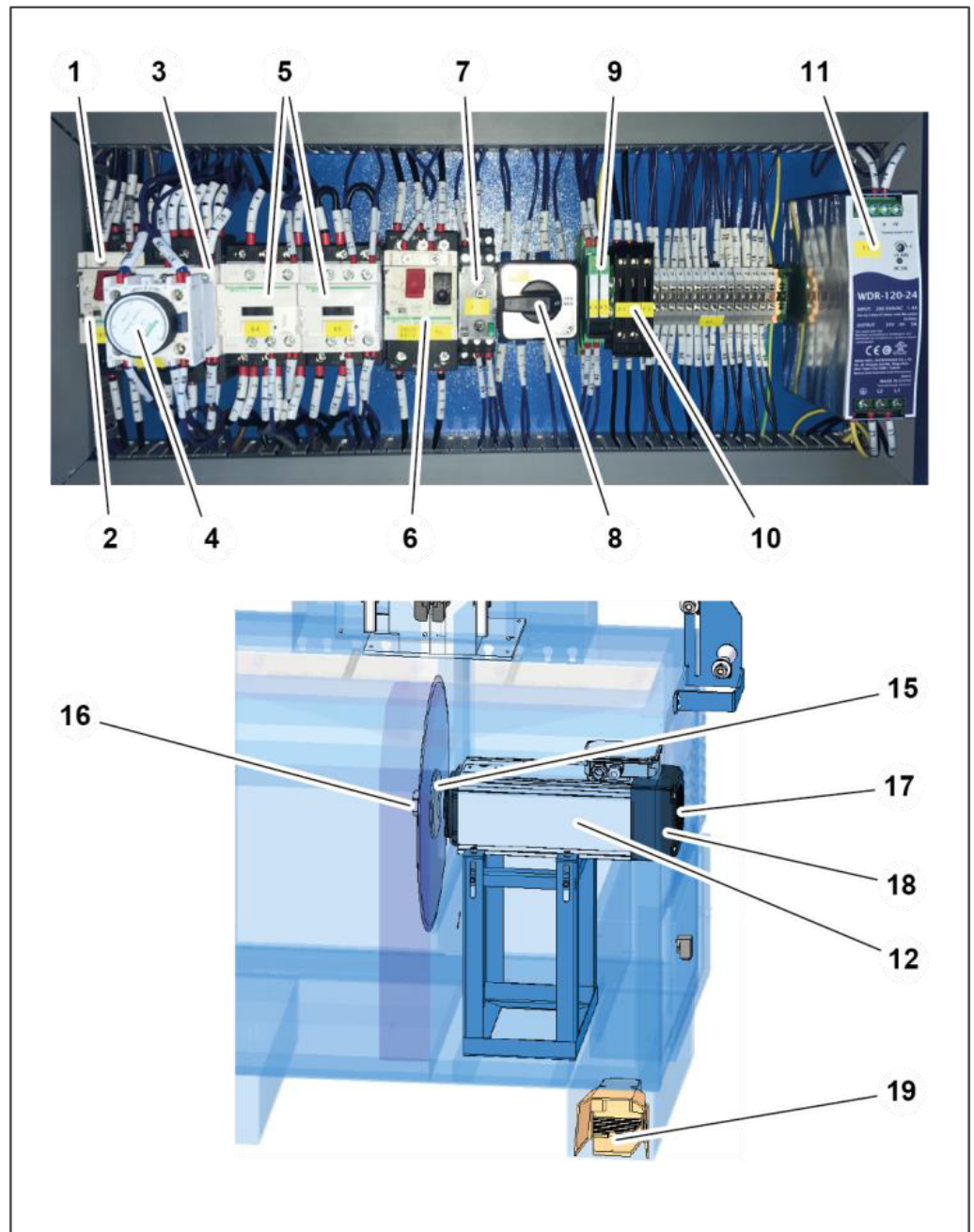

Item	Quantity	Part code	Designation
1	1	888.641	Assistance switch
2	1	888.639	Motor protection switch 24 – 32 A
3	1	888.642	Contacteur 24 V DV
4	1	888.645	Time block 0.1 – 30 s
5	2	888.643	Contacteur 24 V DC

9 Annex

9.2 Spare parts list

Item	Quantity	Part code	Designation
6	1	888.640	Motor protection switch 13 – 18 A
7	1	888.646	Time relay, pick-up delayed
8	1	888.647	Voltage selector switch
9	2	PLC-RSC24DC/21AU	Relay
10	4	VME 0231	Microfuse 3,15 A delayed / 500 V
11	1	888.648	Switching power supply
12	1	306.083	Brake motor 7.5 kW
No picture	1	8.00.030	Metal oxide varistor
No picture	1	306.089	Spare brake for electric motor
15	1	306.090	Set of flange discs
16	1	306.091	Shaft nut
17	1	306.093	Fan wheel for 306.083
18	1	306.094	Fan wheel cover for 306.083
19	1	PS	Foot switch for control

9.2.4 Electric control unit

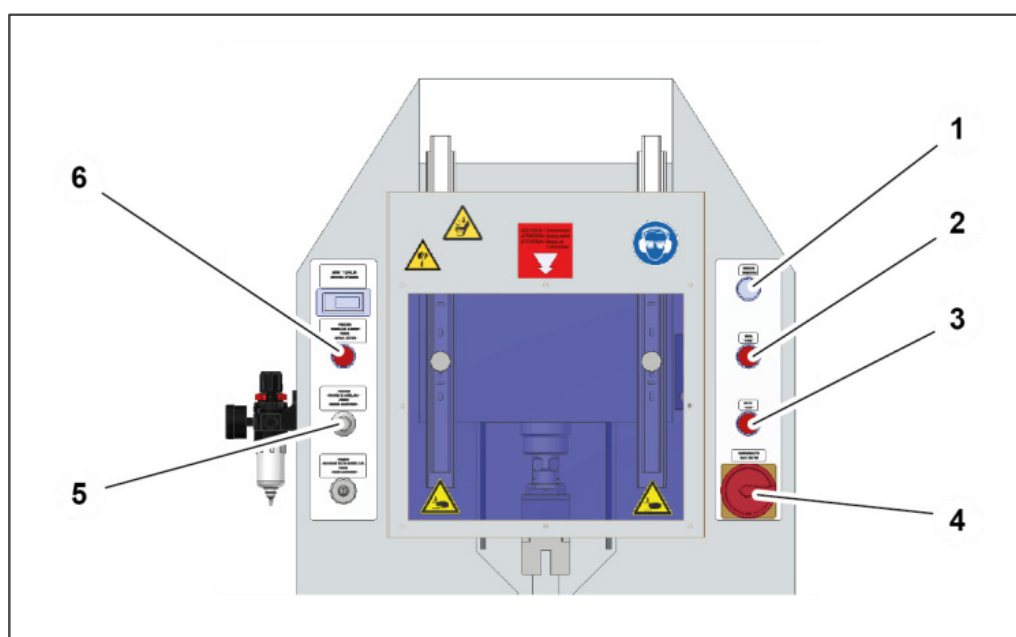

Item	Quantity	Part code	Designation
1	1	UJ_20.30.158	Indicator light

9 Annex

9.2 Spare parts list

Item	Quantity	Part code	Designation
2	1	UJ_20.30.160	Start button motor
3	1	UJ_20.30.170	Motor stop button
4	1	UJ_20.30.171	Main Switch
5	1	UJ_20.30.166	Potentiometer
6	1	UJ_20.30.189	Button for raising the cylinder piston

9.2.5 Wear parts

Quantity	Part code	Designation
1	TMC 520x4x40	Cutting knife, coated
2	UJ_70.0410.11	Protective plates for cutting knife
1	PJ_70.0410.10	Pressure spring (Set = 4 pieces)

9 Annex

9.4 Pneumatic diagram

9.4 Pneumatic diagram

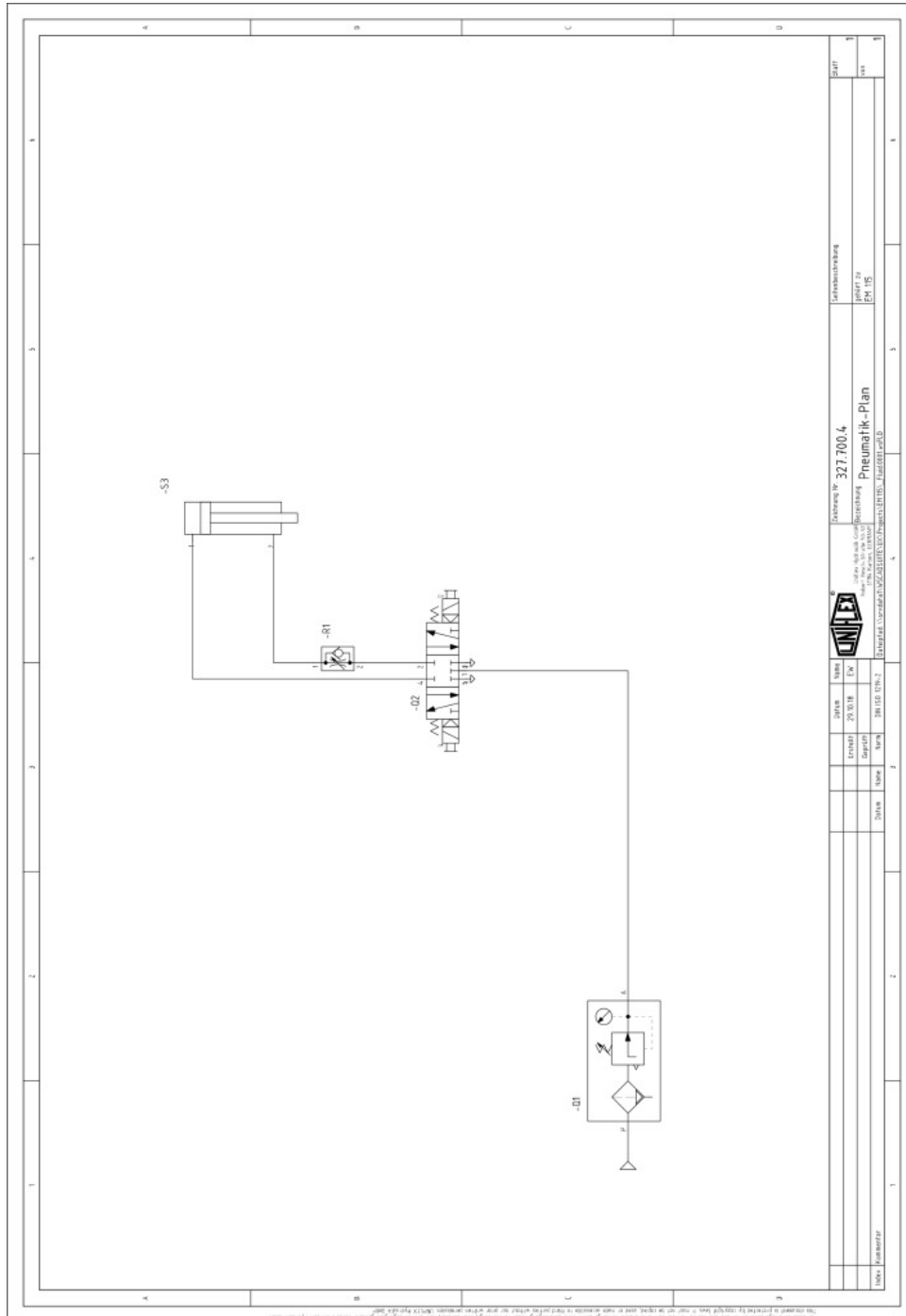

9 Annex

9.6 Declaration of qualified staff

9.6 Declaration of qualified staff

I herewith declare that I have attended an internal training for the operation of the UNIFLEX machine and have been informed on all safety-related details. In addition I declare that I have read and understood this Operation Manual completely.

--	--	--	--

City

Date

Name

Signature

--	--	--	--

City

Date

Name

Signature

--	--	--	--

City

Date

Name

Signature

--	--	--	--

City

Date

Name

Signature

--	--	--	--

City

Date

Name

Signature

--	--	--	--

City

Date

Name

Signature

9 Annex

9.6 Declaration of qualified staff

9 Annex

9.6 Declaration of qualified staff

About Danfoss Power Solutions FC

We sincerely appreciate your choice in selecting this product as part of the range of tooling products distributed by Danfoss.

Danfoss hoses, fittings, and tooling provide the ultimate fluid conveyance solutions for a variety of equipment and applications around the world. We proudly engineer to support a sustainable future for tomorrow.

To learn more please visit: <http://www.danfoss.com/en/about-danfoss/our-businesses/power-solutions>

Danfoss Power Solutions

14615 Lone Oak Road
Eden Prairie, MN 55344, USA
Phone: 952-937-9800

Danfoss Power Solutions II GmbH

Fluid Conveyance
Dr. -Reckeweg-Str. 1
DE-76532 Baden-Baden
Tel.: +49 7221 6820
Machine and tooling selection hotline: FcMachineSupportEMEA@danfoss.com
Service and repair Hotline: FcMachineRepairsEMEA@danfoss.com

Danfoss Power Solutions (US) Company

2800 East 13th Street
Ames, IA 50010, USA
Phone: +1 515-239-6000

Danfoss Power Solutions GmbH & Co.OHG

Krokamp 35
D-2439 Neumünster, Germany
Phone: +49 4321 871 0

Danfoss Power Solutions ApS

Nordborgvej 81
DK-6430 Nordborg, Denmark
Phone: +45 7488 2222

Danfoss Power Solutions Trade (Shanghai) Co. Ltd.

Building #22, No 1000 Jin Hai Rd
Jin Qiao, Pudong New District
Shanghai, China 201206
Phone: +86 21 3418 5200w

Thank you for participating in the Danfoss tooling program. We are pleased to offer you high-quality tooling machines manufactured by our trusted partner, Uniflex. These machines are designed to meet the rigorous standards of our industry, ensuring reliability, precision, and efficiency in your operations. We are committed to providing you with the best tools to support your success.

Danfoss can accept no responsibility for possible errors in catalogs, brochures, and other printed material. Danfoss reserves the right to alter its products without notice. This also applies to products already on order provided that such alterations can be made without subsequent changes being necessary in specifications already agreed. All trademarks in this material are the property of the respective companies. Danfoss and the Danfoss logotype are trademarks of Danfoss A/S. All rights reserved.