

ENGINEERING  
TOMORROW

*Danfoss*

Operator's Manual

# ET9400 Cutting Machine



# Imprint

**Manufacturer:**

UNIFLEX-Hydraulik GmbH  
Robert-Bosch-Strasse 50-52  
D-61184 Karben  
Germany

Phone: +49 (0) 60 39 / 91 71 - 0

Fax: +49 (0) 60 39 / 91 71 - 181

**This Operating Manual of the machine is a translation; the original is in German.**

**Date of revision: 2024-07-22**

**Version: 1.1**

© Copyright by UNIFLEX-Hydraulik GmbH

Technical modifications reserved.

The reproduction, distribution and utilization of this document as well as the communication of its contents to others without explicit authorization are prohibited. Offenders will be held liable for the payment of damages. All rights reserved in the event of the grant of a patent, utility model or design.

## EC / UK - Declaration of Conformity

In accordance with EC Machinery Directive 2006/42/EC and UK-Supply of Machinery (Safety) Regulations 2008.

The following machine

ET9400

was developed, designed and manufactured in compliance with EC Directive 2006/42/EC and UK-Supply of Machinery (Safety) Regulations 2008, in the sole responsibility of

UNIFLEX-Hydraulik GmbH  
Robert-Bosch-Strasse 50 - 52  
D-61184 Karben

The following standards, codes and specifications have been applied:

- EC Directive 2006/42/EC
- EMC Directive 2014/30/EC
- EN ISO 12100: 2010
- EN 60204-1: 2018
- UK-Supply of Machinery (Safety) Regulations 2008
- UK-Electromagnetic Compatibility Regulations 2016

This declaration are invalid when the machine is modified or if unauthorized and unapproved third-party components are used without our prior approval.

Entity authorised for documentation: Uniflex-Hydraulik GmbH, Technical Documentation Dept.

Karben, 04.10.2022



Managing Director Harald von Waitz

# Contents

<b>1</b>	<b>About this document</b> .....	<b>6</b>
1.1	Target groups .....	6
1.2	Storage .....	8
1.3	Name plate .....	8
1.4	Abbreviations .....	8
<b>2</b>	<b>Safety instructions</b> .....	<b>9</b>
2.1	Presentation of warnings .....	9
2.2	Intended use .....	9
2.3	Product-specific risks .....	10
2.3.1	Risks imposed by mechanical equipment .....	10
2.3.2	Risks imposed by electricity .....	11
2.3.3	Risks imposed by noise .....	11
2.3.4	Risks in case of fire .....	11
2.4	Safety .....	12
2.4.1	Working area .....	12
2.4.2	Warning signs on the machine .....	13
<b>3</b>	<b>Machine description</b> .....	<b>15</b>
3.1	Design and function .....	15
3.2	Technical data .....	17
<b>4</b>	<b>Transport and commissioning</b> .....	<b>19</b>
4.1	Transport .....	19
4.2	Intermediate storage of machine/unit .....	20
4.3	Commissioning .....	20
4.3.1	Extraction .....	22
4.3.2	Extraction process for TMC cutting knife .....	22
4.3.3	Electrical connection .....	23
<b>5</b>	<b>Operation</b> .....	<b>25</b>
5.1	What you have to observe .....	25
5.2	Start .....	25
5.3	Work piece cutting .....	26
5.3.1	Prerequisites .....	26
5.3.2	Hose cutting .....	27
5.4	Stop .....	28

## Contents

---

5.5	Overload protection.....	28
5.6	Cleaning.....	29
<b>6</b>	<b>Maintenance.....</b>	<b>31</b>
6.1	What you have to observe .....	31
6.2	Maintenance schedule.....	31
6.3	Knife replacement.....	33
<b>7</b>	<b>Troubleshooting .....</b>	<b>35</b>
<b>8</b>	<b>Decommissioning, disposal .....</b>	<b>36</b>
8.1	Dismantling .....	36
8.2	Recycling .....	36
8.3	Consumables and waste.....	37
<b>9</b>	<b>Annex .....</b>	<b>38</b>
9.1	Accessories (upgradable) .....	38
9.2	Spare parts list.....	39
9.2.1	Mechanical / Electrical .....	39
9.2.2	Wear parts .....	40
9.3	Electric diagram .....	41
9.4	Maintenance log.....	43
9.5	Declaration of qualified staff.....	45

## 1 About this document

### 1.1 Target groups

---

## 1 About this document

The "Cutting machine ET9400" is consistently designated as machine in this Operation Manual.

This Operation Manual includes important notes on how you operate your machine/unit safely, properly and economically.

Use not in compliance with the intended purpose may result in hazard to the operator's health and life and/or in the risk of damage to/the machine/unit. Consequently, please only use the machine/unit

- in good order and condition,
- in accordance with its intended purpose,
- in a safety-conscious manner, with awareness of risks and hazards,
- in compliance with all notes included in this Operation Manual.

The machine/unit may only be operated by staff who

- has read the Operation Manual,
- has understood it,
- has been instructed in the operation of the machine/unit, and
- has signed in the Annex.



Figures may include accessories/options. Customer-specific equipment may vary.

The product images shown are for reference only and may differ from the product delivered.

### 1.1 Target groups

The target groups of this Operation Manual are:

#### **Owner**

An owner is a natural person or entity using the device himself/herself/itself, or on whose behalf the device is used. An owner may appoint a representative to exercise the owner's rights and obligations.

The owner has to make sure that

# 1 About this document

## 1.1 Target groups

---

- national provisions, occupational safety regulations and applicable environmental protection regulations are fully complied with;
- persons working on the machine/unit are adequately qualified;
- persons working on the machine/unit are suitable for operating the machine/unit;
- the Operation Manual has been read and understood. One hardcopy of the Operation Manual must always be kept at a designated place where the machine/unit is used.
- persons working on the machine/unit are aware of potential risks;
- the operating staff is familiar with the location as well as with operating the fire alarm and fighting means. Free access to this equipment must be ensured.
- personal protection equipment is worn (safety footwear, protection gloves and safety glasses).

### **Machine/unit fitters**

Machine/unit fitters must be at least 18 years old and have completed training for the task, i.e. they must have attended a specialist vocational training.

#### A fitter

- must observe the instructions in the Operation Manual;
- must inform the owner on failures and damage.

### **Operator**

An operator is a person charged with and instructed in the proper operation of the machine/unit by the owner or the otherwise contractually obliged person.

#### The operator

- must observe the instructions in the Operation Manual;
- must inform the owner on failures and damage.
- must not perform and maintenance or repair work on the machine/unit.

# 1 About this document

## 1.2 Storage

---

### 1.2 Storage

The Operation Manual is part of the machine/unit and must be kept near the machine/unit at all times. Upon disposal of the machine/unit, the Operation Manual must also be handed over.

### 1.3 Name plate

The name plate is fixed near the power cable.

### 1.4 Abbreviations

TM	cutting knife, plain
TMG	cutting knife, with slots
TMC	cutting knife, coated



## 2 Safety instructions

### 2.1 Presentation of warnings

---

## 2 Safety instructions

### 2.1 Presentation of warnings

Warning notes in the Operation Manual warn against risks involved with the handling of the machine/unit. Risk levels are identified as follows:

**HAZARD!**

The signal word HAZARD identifies an imminent hazard resulting in serious injuries or death. This warning is supplemented by a triangular hazard symbol.

**WARNING!**

The signal word WARNING identifies a potentially hazardous situation, which might result in serious injuries or death. This warning is supplemented by a triangular hazard symbol.

**CAUTION!**

The signal word CAUTION identifies a potentially hazardous situation, which might result in light injuries. This warning is supplemented by a triangular hazard symbol.

**ATTENTION!**

The signal word ATTENTION identifies a potentially hazardous situation, in which the product or property in the environment may be damaged. This warning is supplemented by a hazard symbol or an exclamation mark.

### 2.2 Intended use

This machine is intended for industrial use; it is only suitable for cutting pneumatic and hydraulic hoses up to a specific permissible diameter, see “Technical Data” in Section 3.

Intended purposes include:

- Single user workplace for one person only
- Manual input and retrieval
- Operating temperatures between 5 °C and 40 °C
- Operation in a closed operation room
- The machine must not be operated by persons not capable of operating the machine without any risk. These may include:
  - persons with physical or mental disabilities;
  - children and persons under age;

## 2 Safety instructions

### 2.3 Product-specific risks

---

- persons with a restricted capability for the operation of machines (e.g. under the influence of drugs, alcohol or narcotics)

Use of the control in compliance with the intended purpose also includes compliance with the instructions in this Operation Manual.

#### **Use for other than the intended purpose**

Any other use is considered as being not in compliance with the intended purpose, in particular:

- Design modifications of the machine
- Use in explosive environments
- Use of impermissible cutting knives
- Cutting of inflexible workpieces
- misuse of consumables and waste materials.

<b>WARNING!</b>	
	<p><b>Risk for life and health!</b></p> <p>Use not in compliance with the intended purpose imposes risks for life and health. Consequences resulting from use for other than the intended purpose shall be under the sole responsibility of the owner.</p> <ul style="list-style-type: none"><li>• Always use the machine in compliance with its intended purpose.</li></ul>

## 2.3 Product-specific risks

The machine/unit is designed in accordance with the latest state of technology. Nevertheless, the machine/unit may impose risks:

### 2.3.1 Risks imposed by mechanical equipment

#### **Cutting risk**

A cutting risk exists during cutting and when the cutting knives are replaced.

- Take care and wear cut-proof protective gloves when cutting and replacing knives.

## 2 Safety instructions

### 2.3 Product-specific risks

---

#### **Risk of squeezing**

There is a risk of squeezing on the moving parts.

#### **Tilting hazard**

The risk of tilting mainly exists while the machine is being transported.

- Observe the machine's centre of gravity during transport.

#### **2.3.2 Risks imposed by electricity**

There is a risk of electrocution near the live parts!

- Work on electric systems may only be performed by qualified electricians or instructed and trained persons under the supervision of a qualified electrician.
- Deactivate the machine/unit and secure it against unintentional restart before maintenance.

#### **2.3.3 Risks imposed by noise**

The noise level meter acc. to IEC 804, Class 2, was calibrated before measuring.

The operation of the machine causes noise emissions of 80 dB(A) at the workplace. Noise protection is required.

Higher noise emissions may occur when other machinery is simultaneously used at the workplace. The machine owner must provide for appropriate protection, e.g.

- instruct staff to wear ear protection;
- provide information/instructions on risks
- identify hazardous areas
- provide health monitoring

#### **2.3.4 Risks in case of fire**

The operating staff has to be familiar with the location as well as with operating the fire alarm and fighting means. Free access to this equipment must be ensured.

Use extinguishing powder in case of fire.

## 2.4 Safety

### 2.4.1 Working area

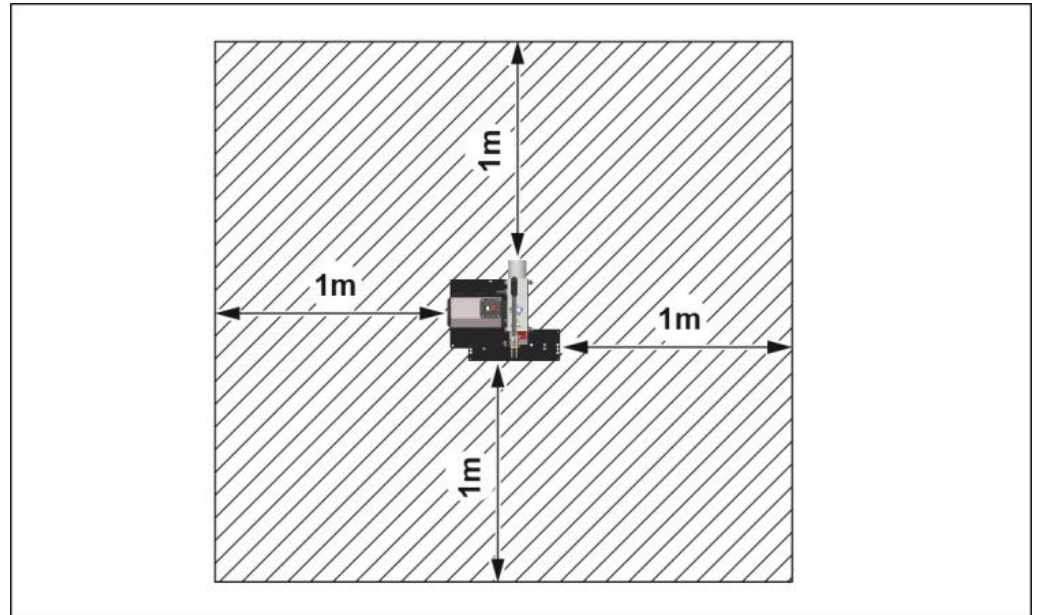

The working area is designed as the area 1 metre all around the machine (shaded).

- Keep the working area free from trip hazards
- Use ducts for lines and cables
- Provide good illumination





## 2 Safety instructions

### 2.4 Safety

---

#### 2.4.2 Warning signs on the machine



	<b>Cutting risk</b> on the cutting knife
	<b>Danger from electric current</b> at the power supply line
	<b>Risk of eye injuries</b> Wear safety goggles
	<b>Risk of hearing damage</b> Wear ear protection

Illegible or missing warning signs must immediately be replaced by the owner.

## 2 Safety instructions

### 2.4 Safety

---

## 3 Machine description

### 3.1 Design and function

#### Basic machine

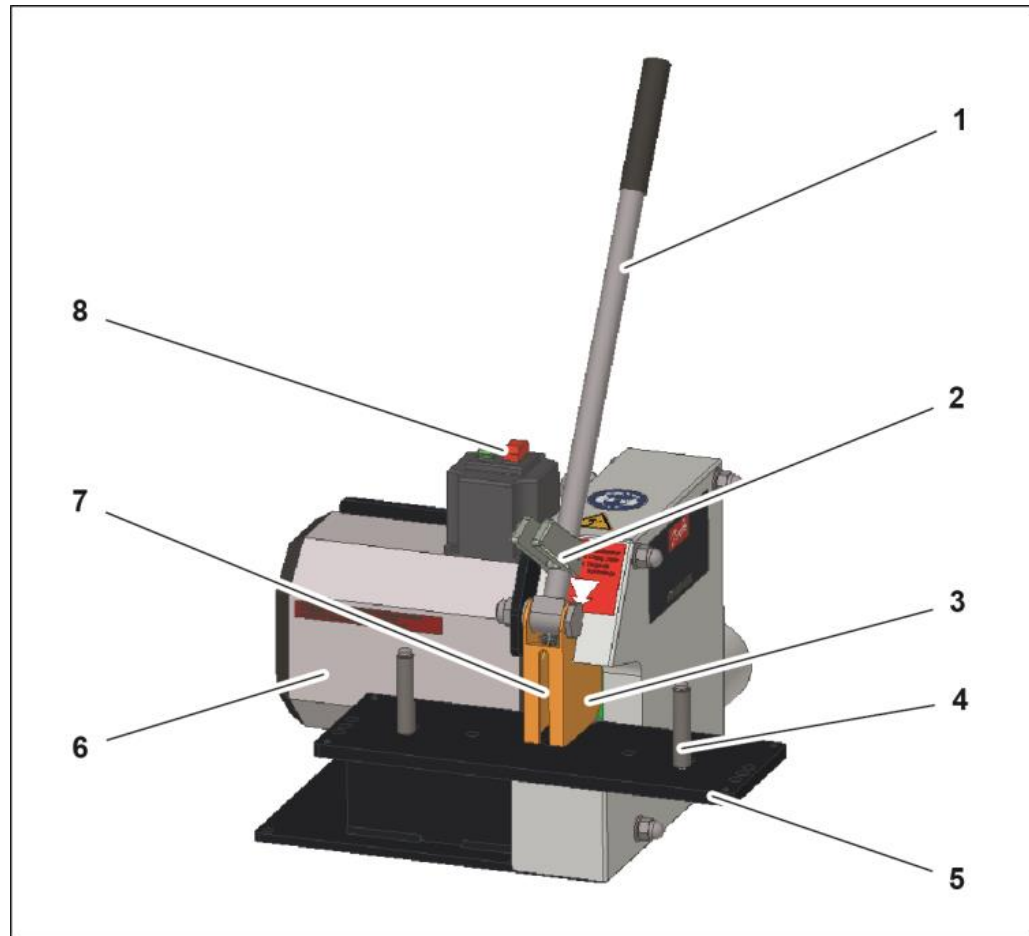

- (1) Hand lever
- (2) Retractable fork
- (3) Knife protection (yellow)
- (4) Bending pin
- (5) Cutting plate
- (6) Motor
- (7) Knife (covered)
- (8) Main power switch (red = OFF / grün = ON)

The workpiece is positioned on the cutting plates (5) in front of the bending pins (4). During the cutting process, the hand lever (1) is moved downwards, in the direction of the cutting plate (5). During

## 3 Machine description

### 3.1 Design and function

---

cutting, the workpiece is moved towards the knife (7) by the retractable fork (2). The knife (7) is driven by the motor (6). Move the Hand lever (1) back to the starting position after cutting.

#### **Accessories**

The machine may be fitted with accessories. A list of the available accessories is included in the Annex, Section "Accessories".



## 3 Machine description

### 3.2 Technical data

---

#### 3.2 Technical data

##### Machine

Dimensions L x W x H	540 x 440 x 300 mm
Weight	approx. 43 kg
Noise level	80 dB(A)*
Protection class	IP 42
Operation mode	S6-40%

##### Function

Hose feed	Manual
Extraction connection	Ø 80 mm
Cutting knife	TM G 275 x 3 x 30 mm

##### Workpiece capacity

Workshop SAE R13 & SAE R15	1 1/4"
Production SAE R13 & SAE R15	3/4"
SAE R12	1 1/4"
Industry	2"
Max. outside	Ø 80 mm

## 3 Machine description

### 3.2 Technical data

---

#### Electric connection

Connection power	3 kW
Connected voltage (model-specific)	400 V $\pm$ 10% 50/60 Hz, 3 phases (_00)+ PE 230 V $\pm$ 10% 60 Hz, 3 phases (_20)+ PE Other, customer-specific voltage variants may exist.
Back-up fuse	400 V = 16 A (delayed) 230 V = 20 A (delayed)

#### Workbench

Solid, plane workbench with a carrying capacity of	approx. 500 kg
--	----------------

#### We recommend industrial flooring meeting the following structural requirements

Permanent floor loading	Approx. 0.07 kg/mm <sup>2</sup>
Floor carrying capacity	Min. 2500 kg/m <sup>2</sup>
Floor quality	B25
Evenness	Max. unevenness 5 mm/m
Inclination	max. 5 mm/m

#### Ambient conditions

Ambient temperature	5 °C – 40 °C
Air humidity	45 % – 65 %

The \*data are theoretical/computed values, or values measured on a prototype. Actual values may vary slightly, depending on the machine.

## 4 Transport and commissioning

### 4.1 Transport

## 4 Transport and commissioning

### 4.1 Transport

The goods should be transported in the original packaging. During transport, the goods must be secured safely within the packaging. All applicable laws and regulations relating to securing loads shall be observed during transport.

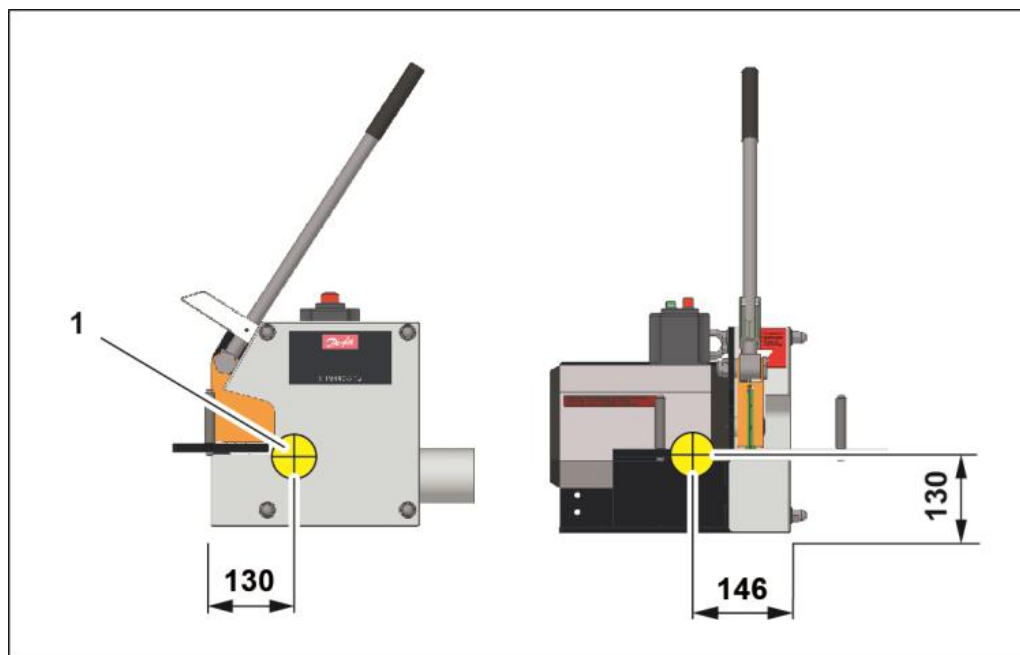

The machine can only be transported manually. For machine weight, please refer to "Technical data" in Section 3.

### WARNING!



#### Risks by dropping loads!

Risk of injuries by dropping loads.

- Do not stand under suspended loads.

## 4 Transport and commissioning

### 4.2 Intermediate storage of machine/unit

---

<b>WARNING!</b>	
	<p><b>Risk due to increased load weights!</b></p> <p>The machine has a weight of over 25kg.</p> <ul style="list-style-type: none"><li>• Transport the machine in twos.</li><li>• Use transport aids.</li></ul>

1. Lift the machine manually and transfer it to the relevant location.

### 4.2 Intermediate storage of machine/unit

If the machine/unit cannot be mounted immediately upon delivery, it must be protected against:

- Contamination,
- Weather influences,
- Mechanical damage.

The machine/unit components may only be stored in closed rooms and under the following conditions:

- temperature between 10°C and 35°C,
- maximum air humidity 80% (non-condensating).

### 4.3 Commissioning

The machine is commissioned by the customer's fitter.

1. Lift the machine manually and place it on the optionally supplied table.
2. Position the cutting plate flush with the table edge.

## 4 Transport and commissioning

### 4.3 Commissioning

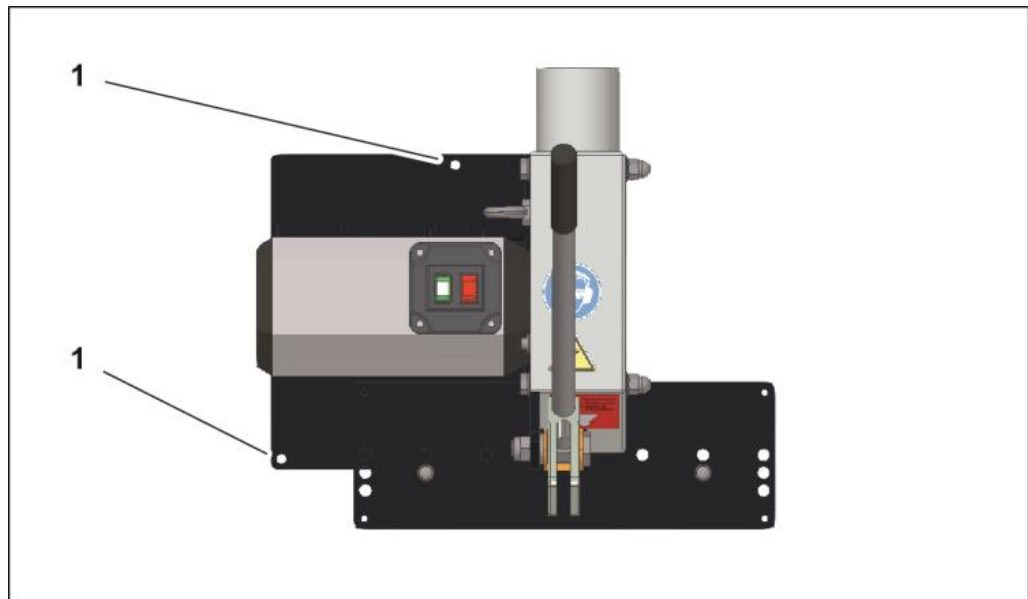

3. Fix the machine on the workbench using suitable screws in the holes  $\varnothing 10$  (1)



Place the machine in a way so that it is easily accessible for maintenance work from all sides.

4. Check the machine for damage.
5. Check the electric cables for damage.
6. Train the operating staff and record training sessions in “Declaration of trained staff”, Section 9.

#### WARNING!



##### **Risk of injuries!**

Machine components might loosen during transport. Such components might be flung out during the cutting process. There is a risk of being injured.

- Perform a cutting process in idle mode and without a work piece.
- Check the machine for atypical noise.

## 4 Transport and commissioning

### 4.3 Commissioning

#### 4.3.1 Extraction



1. Mount a metal hose for smoke and particle extraction to the extraction nozzle (1).



We recommend an extraction fan with 100mm water column and a capacity of 4m<sup>3</sup>/min, as well as a filter element and a spark separator suitable for this purpose.

#### 4.3.2 Extraction process for TMC cutting knife

##### WARNING!



##### Risk of fire

During cutting, there is a risk for life and health due to the fire hazard from flying sparks.

- Only operate the machine with a spark extinguisher.
- Clean the machine and spark extinguisher after each use (see “Cleaning” in Section 5).

## 4 Transport and commissioning

### 4.3 Commissioning

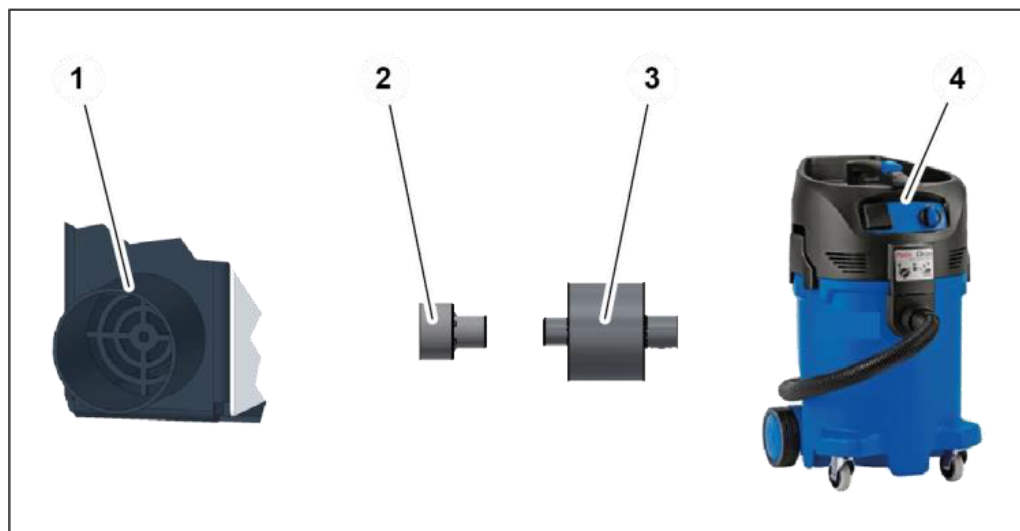

1. Attach the adapter (2) to the extraction nozzle (1) of the machine.
2. Attach the spark extinguisher (3) to the adapter (2).
3. Attach the metal hose to the spark extinguisher (3) and extraction device (4).



We recommend an extraction fan with 100 mm water column and a capacity of 4 m<sup>3</sup>/min, as well as a filter element suitable for this purpose.

#### 4.3.3 Electrical connection

##### WARNING!



##### Risk by electrical voltage!

There is a risk of electrocution near the live parts!

- Work on electric systems may only be performed by qualified electricians or instructed and trained persons under the supervision of a qualified electrician.
- Do not operate the machine without a sufficiently rated ground wire.
- Deactivate the machine and secure it against unintentional restart before maintenance.

## 4 Transport and commissioning

### 4.3 Commissioning

---

1. Disconnect the power supply for the machine and secure it against unintentional restart.
2. Have the power cable of the machine connected to the local mains by a qualified electrician according to the regulations of the Electricity Board.
3. Check the electric motor rotational direction according to the arrow. Exchange outer cable (phases) of the connection, if required.

#### ATTENTION!



##### **Risk of damage to machinery!**

Operating the motor in the wrong direction of rotation results in the loosening of the knife attachment.

- Ensure that the rotational direction of the motor is correct. Observe the red arrow on the motor cover.
- If the motor has been operated in the wrong direction of rotation, the securing nut and/or bolt has to be tightened as described in Section 6 "Knife replacement".



## 5 Operation

### 5.1 What you have to observe

---

## 5 Operation

### 5.1 What you have to observe

The operator has received the Operation Manual from the owner, has read and understood it and will observe it.

#### Before starting and/or re-starting

- Ensure sufficient illumination of the working area of the machine.

#### During operation

- Observe the safety instructions on the machine.
- Make sure that no other persons stay in the working area.
- Each movement of the hand must be observed.
- Eating, drinking and smoking at the workplace is prohibited.
- Wear close-fitting clothes.
- Do not wear watches or jewellery.

### 5.2 Start

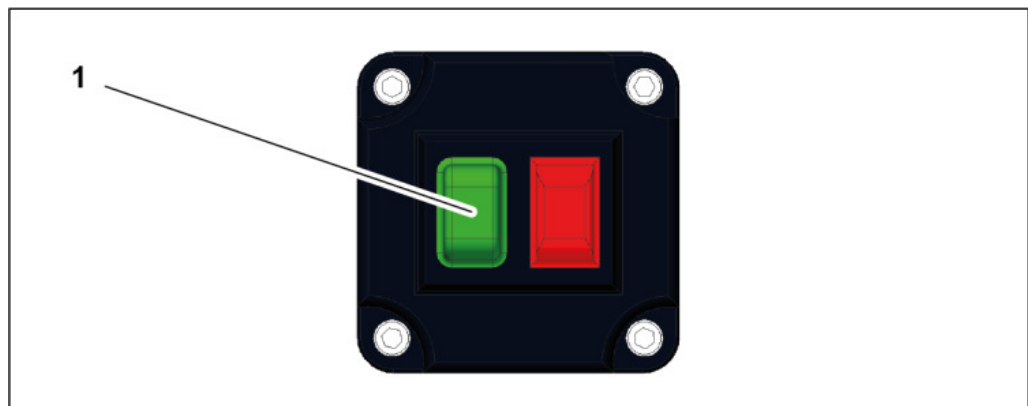

4. Activate the power switch (1) (red = OFF / green = On).

## 5.3 Work piece cutting

### 5.3.1 Prerequisites

#### ATTENTION!



#### Damage to the machine

The knife may be damaged when the machine is operated without hose prestressing.

- Never cut without bending (X).
- Adjust the bending pin and the workpiece.

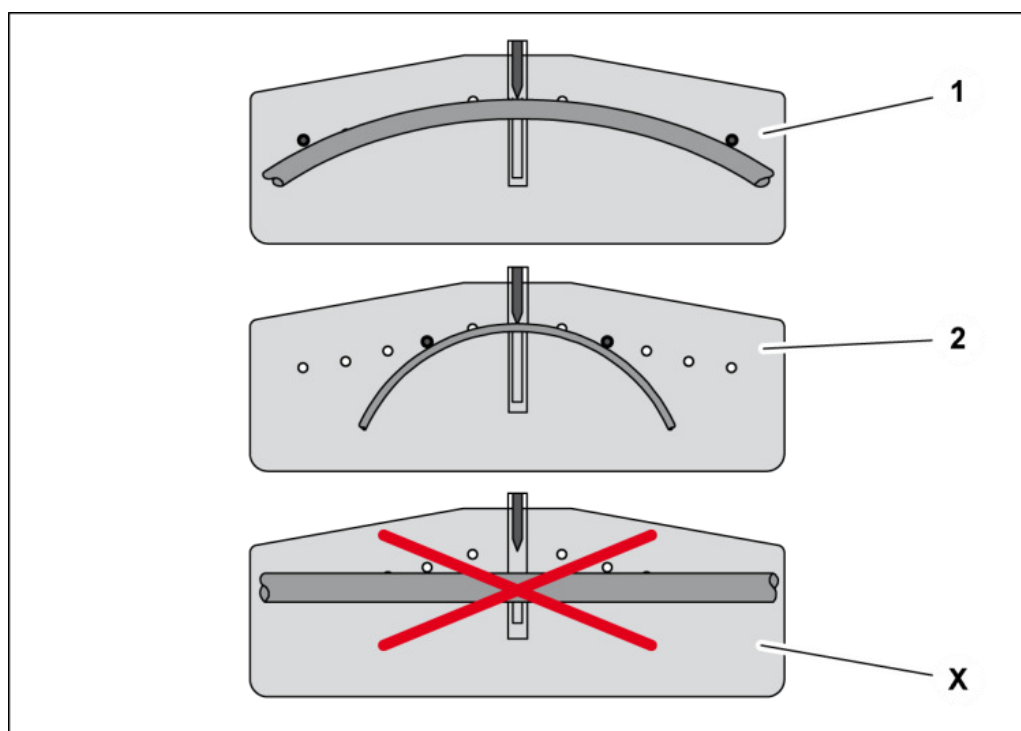

Prerequisites for a correct cutting process:

- The bending pin position and the hose diameter are matched to each other:
  - (1) Large hose diameter = large bolt distance
  - (2) Small hose diameter = small bolt distance
- The work piece must protrude over the two bending pins by at least 50 mm.

## 5 Operation

### 5.3 Work piece cutting

- The work piece must completely bear on the cutting plate.

#### 5.3.2 Hose cutting

##### WARNING!



##### Cutting risk!

There is a risk of cutting your extremities when cutting work-pieces.

- When moving the handle, take care that your extremities are not between the retractable fork and the knife protection.

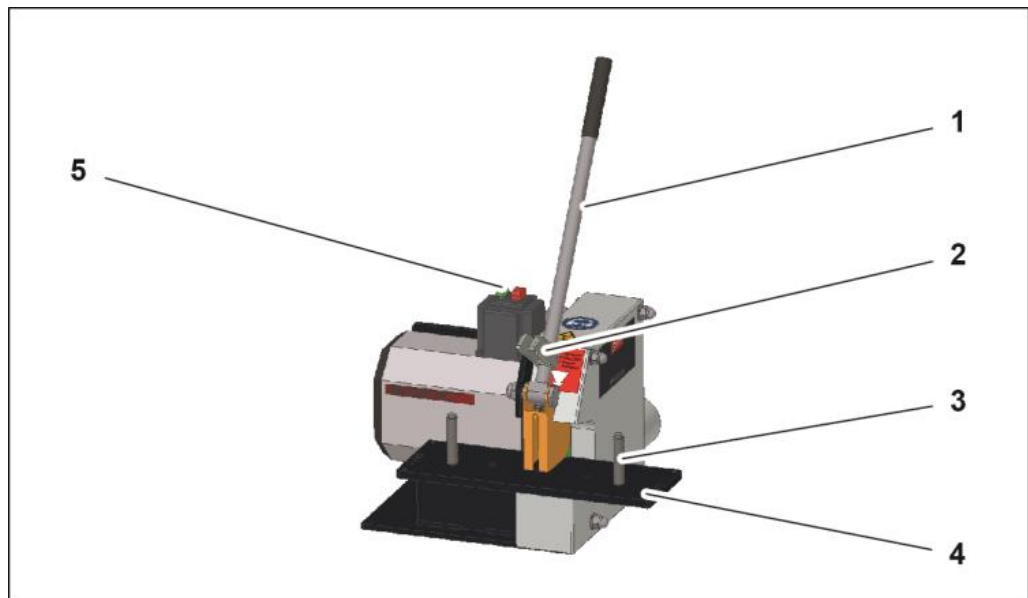

1. Manually place the workpiece on the cutting plate (4) in front of the bending pins (3).
2. Activate the machine at the main power switch (5).
3. Pull hand lever (1) consistently and slowly.
4. The retractable fork (2) guides the workpiece towards the knife.  
The cutting process is completed.
5. Move the hand lever (1) upwards into the starting position.
6. Deactivate the machine at the main power switch (5).
7. Remove the workpiece

## 5.4 Stop

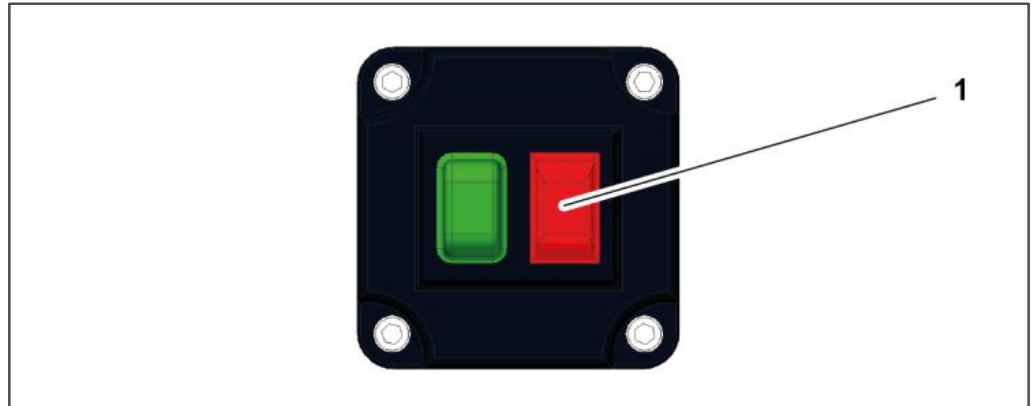

1. Complete the cutting process.
2. Deposit the workpiece outside the machine.
3. Deactivate the power switch (red) (1).
4. Check the machine for contamination and outside damage.
5. Check the cutting knife for damage and cracks.
6. Remove contamination, dust and chips using a vacuum.



Inform the fitter in case of damage or other irregularities.

## 5.5 Overload protection

The motor is protected against overload by a motor protection switch.

After a motor overload, if any, let the motor cool down and restart it.

The restart protection prevents an unintentional restart of the machine. Starting the machine is only possible by activating the main power switch again.

## 5.6 Cleaning

### WARNING!



#### Risk for life and health!

There is an acute risk of injuries when working in the danger zone of the cutting knife.

- Disconnect the machine from all energy sources and secure it against switching on unintentionally.
- Wear cut-proof gloves.

### ATTENTION!



#### Risk of damage to machinery!

If the machine is cleaned with a steam jet or compressed air, dirt and water may ingress in the machine and cause serious damage.

- Do not use a steam jet to clean the machine.
- Do not use compressed air to clean the machine.

1. Use a vacuum cleaner or a soft cloth to clean the machine.



2. Loosen the four screws on the cover plate (1).
3. Remove the cover plate (1).

## 5 Operation

### 5.6 Cleaning

---

4. Vacuum the chassis.
5. Mount cover plate (1).

## 6 Maintenance

### 6.1 What you have to observe

---

## 6 Maintenance

Regular maintenance will ensure the continuous operation reliability of the device.

### 6.1 What you have to observe

This Section describes action to be taken by you as the fitter regularly to ensure the troublefree use of the machine.

- Maintenance work may only be performed by qualified maintenance staff (machine fitters).
- Repair work on the machine or components may only be performed by appropriately qualified expert staff or UNIFLEX experts!
- The machine must always be deactivated during maintenance work (see "Deactivation" in Section 5). Attach a sign. Example text:

Machine out of service for maintenance work!  
Do not switch on!

- Welding, flame-cutting and grinding work on and in the machine and its environment must be approved in advance. There is a risk of fire. The machine must be cleaned from dust and inflammable substances. Adequate ventilation must be ensured.

### 6.2 Maintenance schedule

If not specified otherwise, inspections listed in the maintenance schedule are visual inspection. Replace defective parts.

If you work in 2 shifts, the check frequency has to be doubled. If you work in 3 shifts, you proceed as with 2-shift operation.

Record maintenance work performed in the maintenance log.

## 6 Maintenance

### 6.2 Maintenance schedule

Maintenance item	Weekly	Monthly	Number of years
<b>Cutting tool</b>			
Check cutting knife for sharpness, cracks and breakouts; sharpen or replace the knife. Coating: to be checked (only TMC cutting knife).	X		
Bolted connections: To be checked and retightened, if required.		X	
Machine: To be cleaned.		X	
Extraction line: To be cleaned.			1
<b>Safety equipment</b>			
Knife protection: To be checked for function Press the knife protection on the outside edges towards the motor with both thumbs wearing cutting protection gloves. There must be a significant resistance.	X		
Warning signs on machine: Check legibility (see "Warning signs on the machine" in Section 2).		X	



The replacement of wear parts must be recorded in the maintenance log!



## 6.3 Knife replacement

### WARNING!



#### Cutting risk!

Knife replacement imposes a significant risk of injuries to the hands.

- Always wear cut-proof gloves when replacing the knives.

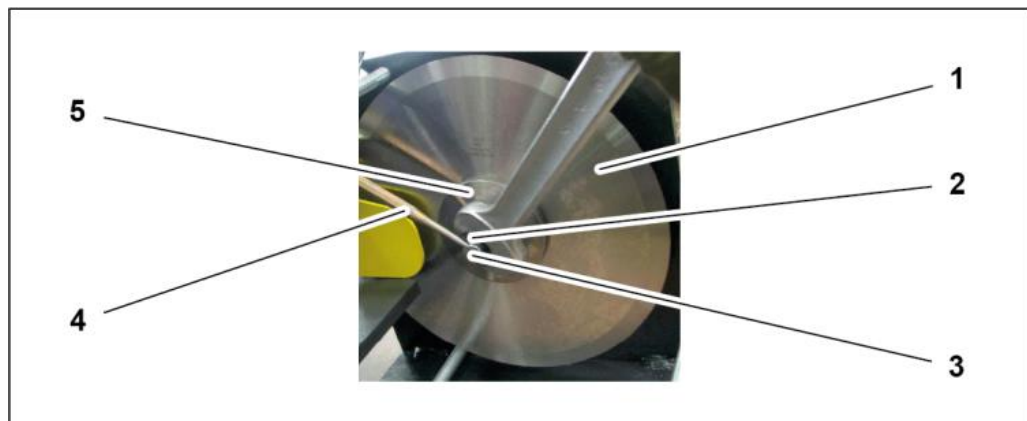

1. Complete the cutting process.
2. Deposit the workpiece outside the machine.
3. Disconnect the machine from the power supply.
4. Loosen the four nuts on the cover plate.
5. Remove the cover plate.
6. Hold the drive shaft (3) using a pin punch (4) and loosen the nut (2) counterclockwise using a jaw or ring wrench SW 30.
7. Remove the knife (1) and the washer (5) from the axle and position them carefully.
8. Mount a new knife - observe cutting direction.
9. Position the washer (5) and tighten the nut (2).
10. Remount in the reverse order.

## 6 Maintenance

### 6.3 Knife replacement

---

#### ATTENTION!



#### **Risk of damage to machinery!**



If the directions of rotation of the motor and the knife do not match, there is a risk that the knife will be destroyed during cutting.

- Check the direction of rotation before starting the machine.

## 7 Troubleshooting

Error	Cause	Remedy
Machine does not cut	Switch "OFF"	Activate switch
	Power plug defective	Check power plug and replace, if required
	Motor defective	Contact Service desk
	Cutting knife worn	Check cutting knife for wear and replace, if required

## 8 Decommissioning, disposal

WARNING!	
	<p><b>Risk by electrical voltage!</b></p> <p>There is a risk of electrocution near the live parts!</p> <ul style="list-style-type: none"><li>• Shut down the machine/unit.</li><li>• Disconnect the machine/unit from the power supply.</li></ul>
CAUTION!	
	<p><b>Risk of injuries!</b></p> <p>Contact with consumables, e.g. oils, greases, test media, imposes a risk of injuries for the skin, eyes, respiratory and intestinal tracts!</p> <ul style="list-style-type: none"><li>• Observe supplier's protection and safety instructions (see data sheet).</li><li>• Wear personal protection equipment.</li><li>• Do not eat, drink or smoke in the working area and when handling consumables.</li><li>• Ensure good ventilation.</li></ul>

### 8.1 Dismantling

This section describes activities to be performed by you as the operator to ensure the safe dismantling of the machine/unit.

- The machine/unit may only be dismantled by entrusted and qualified staff.
- Check the machine/unit for mechanical tension and consider it during dismantling.

### 8.2 Recycling

The machine/unit contains metal, hydraulic hoses, electric cables and electronic components, depending on the type.

As regards disposal, the applicable national environmental protection and waste disposal regulations have to be complied with.

### **8.3 Consumables and waste**

Observe applicable national environmental protection and waste disposal regulations.

Return consumables, e.g. oils, greases, test media, to supplier - they are hazardous waste. Also observe the information given on the safety data sheet.

## 9 Annex



Individual machine/unit components may deviate in their features. Please indicate the serial number of the machine for spare part orders.

### 9.1 Accessories (upgradable)

Accessories	Article code
Hose guide, 2000mm	UHG 14
Extension, 1000mm	UHG 14 EXT
Suction system	UVC S36
Hose length measuring device	UMS 4
Spark extinguisher	330.050
Vacuum adapter	777.056
Bench	TU
Cutting knife with inclined slots	TM G 275x3x30
Cutting knife, coated	TM C 275x3x30
Cutting knife flat	TM 275x3x30
Suction filter system	UVC 100.2 MVA FSD

Please contact our Sales department for ordering optional accessories.

## 9.2 Spare parts list

### 9.2.1 Mechanical / Electrical

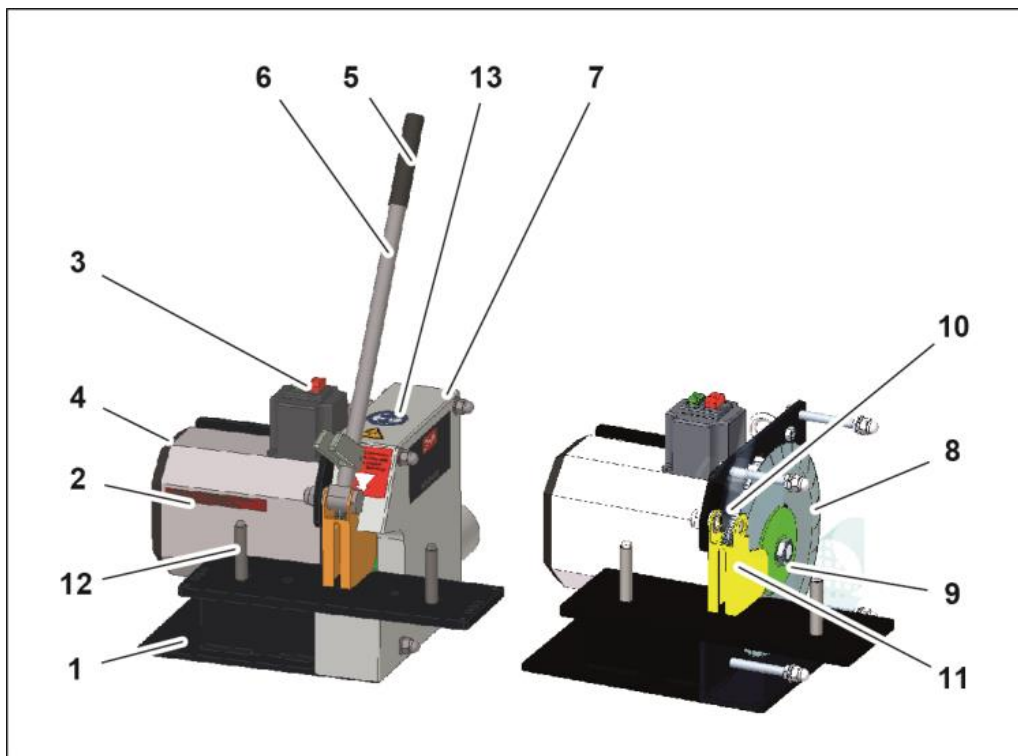

Item	Quantity	Part code	Designation
1	1	301.018.0	Chassis
2	1	300.050	Electric engine 230 V, 400 V; 50 - 60 Hz, 3 phases
3	1	300.051	Spare electrical switch for motor 300.050
4	1	300.052	Spare brake
5	1	Nr. 84 Ø21x120	PFC handle
6	1	300.2001	Hand lever
7	1	301.013.1	Cover
8	1	TM G 275x3x30	Cutting knife
9	2	300.053	Flange disc for motor 300.050
10	1	D-174867	Pressure spring EM3
11	1	301.109.4	Knife protection
12	1	304.2001	Set of bending pins
13	1	300.6000	Sticker set EM3.3

## 9 Annex

### 9.2 Spare parts list

---

#### 9.2.2 Wear parts

Quantity	Article code	Designation
1	TM G 275x3x30	Cutting knife with inclined slots
1	TM C 275x3x30	Cutting knife coated
1	TM 275x3x30	Cutting knife flat



# 9 Annex

## 9.3 Electric diagram

### 9.3 Electric diagram

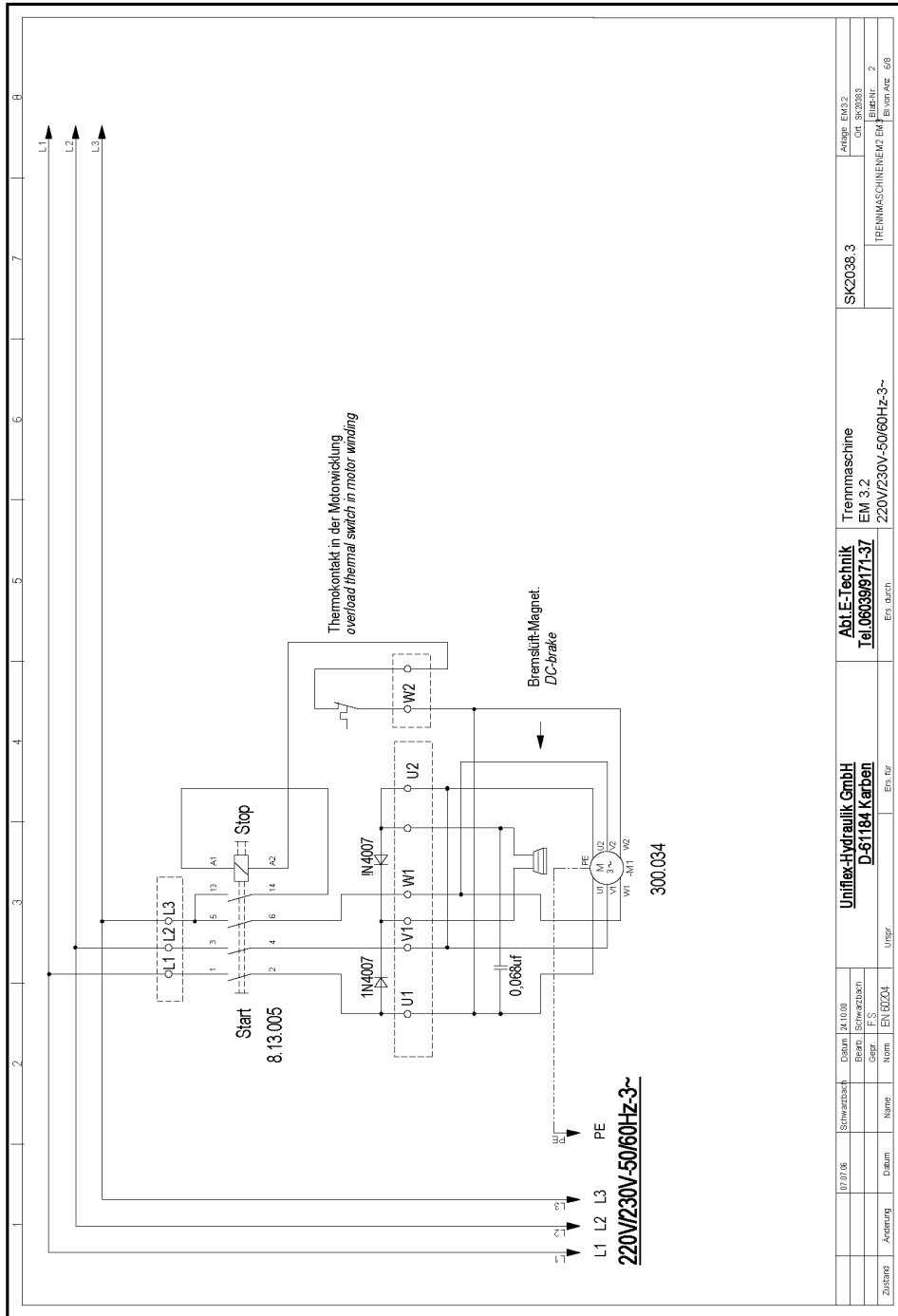

Zustand	Änderung	Datum	Name	Urspr.	Ers. durch	Ers. für
		01.07.08	Schwarzbach	Datum 24.10.08		
				Beleg Schwarzbach		
				Chr. F.S.		
				Norm EN 60204		
<b>Uniflex-Hydraulik GmbH</b>						
<b>D-67184 Karben</b>						
Tel. 069399171-37						
Ers. durch						
Trennmaschine						
EIM 3.2						
220V/230V-50/60Hz-3~						
SK2036.3						
TRENNMASCHINENEM 2						
Bil von Art. 6/8						
Ort SK2036.3						
Anlage EM 2						

# 9 Annex

## 9.3 Electric diagram

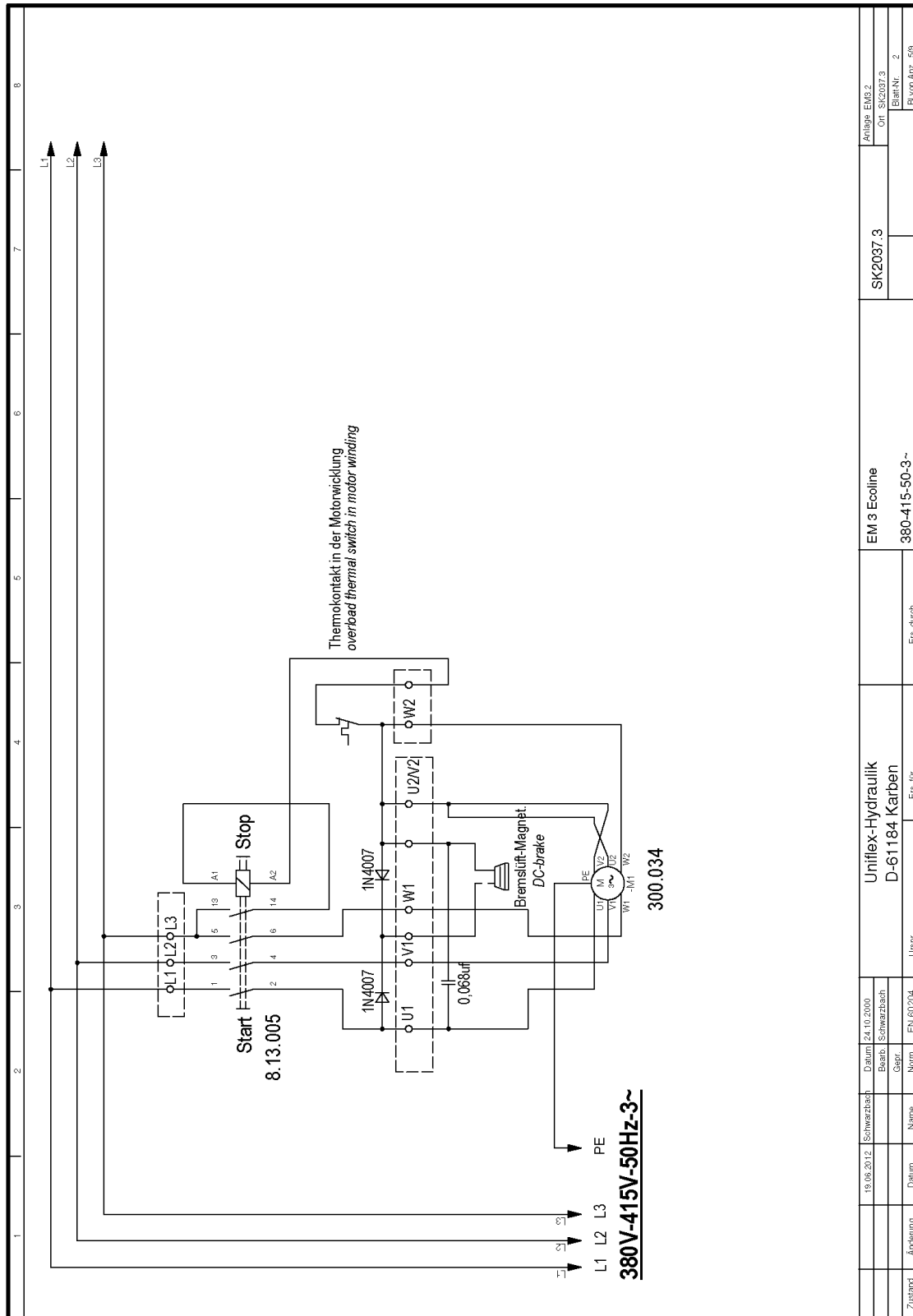

# 9 Annex

## 9.4 Maintenance log

Motorschutz F1 Motor M1	Sicherung F4/F5	Schütz K1M	Transformator T1
motor-controller motor	fuse	contactor	transformer
8.06.002 10A-16A Einstellung 14,6/220/230V	1,25A T 6,3x32mm	8.07.013	L1 0V L2 230V
8.06.001 6,3A-10A Einstellung 8,9A 380V↘	1,0A T 6,3x32mm	1367 121 06 DL7K-DC10	L1 -20V L2 400V
8.06.001 6,3A-10A Einstellung 7,3A 460V↘	1,0A T 6,3x32mm	1367 121 06 DL7K-DC10	L1 0V L2 440V
8.06.001 6,3A-10A Einstellung 6,9A 480V↘	1,0A T 6,3x32mm	1367 121 06 DL7K-DC10	L1 +20V L2 440V
			L1 -20V L2 500V

**Netzkabel 238.044 (4GA)**  
connection cable 232.040 (4G2.5)

**\* 400V-60Hz-3~**

**Ausführung entsprechend Maschinenvariante sowie Netzfrequenz.**  
Variable pump type to correspond with machine type and power frequency!

**Bei abweichender Netzspannung, Transformatoranschluss sowie die Einstellung des Motorschalters, gemäß Tabelle**  
For other voltages consult the settings and the connection of the transformer according to the table.

**Zur Auswahl des richtigen Schaltplanes, Spannungs-Frequenz- und Leistungsangabe auf Maschinen-Typenschild beachten.**  
Check the machine plate to identify the correct circuit diagram. (voltage, cycles, power, etc.)

10.12.14	Schweißbuch	Datum	10.08.00	Umflex-Hydraulik GmbH	Abt.E-Technik	SK 1653.2	Anlage Leihgerät zu Un.B.E.S.
		Beitrag	Schweißbuch	D-61184 Karben	Tel.060399171-37	Leistungsteil zu Unimatic-B/Ea	OR SK1653.2
		Gepr.	F-S			220V-480V 4KW-60Hz-3~	BIENR. 6
		Norm	EN 60204				LEISTUNGSTEIL_(PRESSEN)
		Unspr.					Er von Art. 3102

## 9.4 Maintenance log



## 9 Annex

### 9.5 Declaration of qualified staff

---

#### 9.5 Declaration of qualified staff

I herewith declare that I have attended an internal training for the operation of the UNIFLEX machine and have been informed on all safety-related details. In addition I declare that I have read and understood this Operation Manual completely.

City	Date	Name	Signature

City	Date	Name	Signature

City	Date	Name	Signature

City	Date	Name	Signature

City	Date	Name	Signature

City	Date	Name	Signature

## 9 Annex

### 9.5 Declaration of qualified staff

---

## 9 Annex

### 9.5 Declaration of qualified staff

---

## About Danfoss Power Solutions FC

We sincerely appreciate your choice in selecting this product as part of the range of tooling products distributed by Danfoss.

Danfoss hoses, fittings, and tooling provide the ultimate fluid conveyance solutions for a variety of equipment and applications around the world. We proudly engineer to support a sustainable future for tomorrow.

To learn more please visit: <http://www.danfoss.com/en/about-danfoss/our-businesses/power-solutions>

### **Danfoss Power Solutions**

14615 Lone Oak Road  
Eden Prairie, MN 55344, USA  
Phone: 952-937-9800

### **Danfoss Power Solutions II GmbH**

Fluid Conveyance  
Dr. -Reckeweg-Str. 1  
DE-76532 Baden-Baden  
Tel.: +49 7221 6820  
Machine and tooling selection hotline: [FcMachineSupportEMEA@danfoss.com](mailto:FcMachineSupportEMEA@danfoss.com)  
Service and repair Hotline: [FcMachineRepairsEMEA@danfoss.com](mailto:FcMachineRepairsEMEA@danfoss.com)

### **Danfoss Power Solutions (US) Company**

2800 East 13th Street  
Ames, IA 50010, USA  
Phone: +1 515-239-6000

### **Danfoss Power Solutions GmbH & Co.OHG**

Krokamp 35  
D-2439 Neumünster, Germany  
Phone: +49 4321 871 0

### **Danfoss Power Solutions ApS**

Nordborgvej 81  
DK-6430 Nordborg, Denmark  
Phone: +45 7488 2222

### **Danfoss Power Solutions Trade (Shanghai) Co. Ltd.**

Building #22, No 1000 Jin Hai Rd  
Jin Qiao, Pudong New District  
Shanghai, China 201206  
Phone: +86 21 3418 5200w

Thank you for participating in the Danfoss tooling program. We are pleased to offer you high-quality tooling machines manufactured by our trusted partner, Uniflex. These machines are designed to meet the rigorous standards of our industry, ensuring reliability, precision, and efficiency in your operations. We are committed to providing you with the best tools to support your success.

---

Danfoss can accept no responsibility for possible errors in catalogs, brochures, and other printed material. Danfoss reserves the right to alter its products without notice. This also applies to products already on order provided that such alterations can be made without subsequent changes being necessary in specifications already agreed. All trademarks in this material are the property of the respective companies.  
Danfoss and the Danfoss logotype are trademarks of Danfoss A/S. All rights reserved.