

ENGINEERING  
TOMORROW

*Danfoss*

Operator's Manual

# ET6300 Marking Machine



## Imprint

**Manufacturer:**

UNIFLEX-Hydraulik GmbH  
Robert-Bosch-Strasse 50-52  
D-61184 Karben  
Germany

Phone: +49 (0) 60 39 / 91 71 - 0

Fax: +49 (0) 60 39 / 91 71 - 181

**This Operating Manual of the machine is a translation; the original is in German.**

**Date of revision: 2024-07-25**

**Version: 1.1**

© Copyright by UNIFLEX-Hydraulik GmbH

Technical modifications reserved.

The reproduction, distribution and utilization of this document as well as the communication of its contents to others without explicit authorization are prohibited. Offenders will be held liable for the payment of damages. All rights reserved in the event of the grant of a patent, utility model or design.

## Imprint

---

# Contents

<b>1</b>	<b>About this document</b> .....	<b>6</b>
1.1	Target groups .....	6
1.2	Storage .....	8
1.3	Name plate .....	8
<b>2</b>	<b>Safety instructions</b> .....	<b>9</b>
2.1	Presentation of warnings .....	9
2.2	Intended use .....	9
2.3	Product-specific risks .....	10
2.3.1	Risks posed by mechanical equipment .....	10
2.4	Safety .....	12
2.4.1	Working area .....	12
2.4.2	Warning signs on the machine .....	13
<b>3</b>	<b>Machine description</b> .....	<b>14</b>
3.1	Design and function .....	14
3.2	Technical data .....	16
<b>4</b>	<b>Transport and commissioning</b> .....	<b>18</b>
4.1	Transport .....	18
4.2	Intermediate storage of machine/unit .....	18
4.3	Commissioning .....	19
<b>5</b>	<b>Operation</b> .....	<b>22</b>
5.1	What you have to observe .....	22
5.2	Embossing the work piece .....	23
5.2.1	Prerequisites .....	23
5.2.2	Embossing .....	23
5.2.3	Embossing with steel type holder, single-row with 4 wheels .....	25
5.2.4	Embossing with steel type holder, double-row without wheels .....	26
5.2.5	Embossing with steel type holder, single-row with 4 wheels .....	27
5.2.6	Steel type holder replacement .....	28
5.3	Cleaning .....	30
<b>6</b>	<b>Maintenance</b> .....	<b>31</b>
6.1	What you have to observe .....	31
6.2	Maintenance schedule .....	31

## Contents

---

<b>7</b>	<b>Troubleshooting</b> .....	<b>33</b>
<b>8</b>	<b>Decommissioning, disposal</b> .....	<b>34</b>
8.1	Dismantling .....	34
8.2	Recycling .....	34
8.3	Consumables and waste .....	34
<b>9</b>	<b>Annex</b> .....	<b>35</b>
9.1	Accessories (retrofitable) .....	36
9.2	Spare parts list .....	37
9.3	Spare parts kit .....	38
9.4	Maintenance log .....	39
9.5	Declaration of qualified staff .....	40

## 1 About this document

### 1.1 Target groups

---

## 1 About this document

In this Operation Manual, the “embossing machine ET6300“ is consistently referred to as machine.

This Operation Manual includes important notes on how you operate your machine/unit safely, properly and economically.

Use not in compliance with the intended purpose may result in hazard to the operator's health and life and/or in the risk of damage to/the machine/unit. Consequently, please only use the machine/unit

- in good order and condition,
- in accordance with its intended purpose,
- in a safety-conscious manner, with awareness of risks and hazards,
- in compliance with all notes included in this Operation Manual.

The machine/unit may only be operated by staff who

- has read the Operation Manual,
- has understood it,
- has been instructed in the operation of the machine/unit, and
- has signed in the Annex.



Figures may include accessories/options. Customer-specific equipment may vary.

The product images shown are for reference only and may differ from the product delivered.

### 1.1 Target groups

The target groups of this Operation Manual are:

#### **Owner**

An owner is a natural person or entity using the device himself/herself/itself, or on whose behalf the device is used. An owner may appoint a representative to exercise the owner's rights and obligations.

The owner has to make sure that

# 1 About this document

## 1.1 Target groups

---

- national provisions, occupational safety regulations and applicable environmental protection regulations are fully complied with;
- persons working on the machine/unit are adequately qualified;
- persons working on the machine/unit are suitable for operating the machine/unit;
- the Operation Manual has been read and understood. One hardcopy of the Operation Manual must always be kept at a designated place where the machine/unit is used.
- persons working on the machine/unit are aware of potential risks;
- the operating staff is familiar with the location as well as with operating the fire alarm and fighting means. Free access to this equipment must be ensured.
- personal protection equipment is worn (safety footwear, protection gloves and safety glasses).

### **Machine/unit fitters**

Machine/unit fitters must be at least 18 years old and have completed training for the task, i.e. they must have attended a specialist vocational training.

#### A fitter

- must observe the instructions in the Operation Manual;
- must inform the owner on failures and damage.

### **Operator**

An operator is a person charged with and instructed in the proper operation of the machine/unit by the owner or the otherwise contractually obliged person.

#### The operator

- must observe the instructions in the Operation Manual;
- must inform the owner on failures and damage.
- must not perform and maintenance or repair work on the machine/unit.

## 1 About this document

### 1.2 Storage

---

### 1.2 Storage

The Operation Manual is part of the machine/unit and must be kept near the machine/unit at all times. Upon disposal of the machine/unit, the Operation Manual must also be handed over.

### 1.3 Name plate

The name plate is fixed on the machine back.



## 2 Safety instructions

### 2.1 Presentation of warnings

---

## 2 Safety instructions

### 2.1 Presentation of warnings

Warning notes in the Operation Manual warn against risks involved with the handling of the machine/unit. Risk levels are identified as follows:

**HAZARD!**

The signal word HAZARD identifies an imminent hazard resulting in serious injuries or death. This warning is supplemented by a triangular hazard symbol.

**WARNING!**

The signal word WARNING identifies a potentially hazardous situation, which might result in serious injuries or death. This warning is supplemented by a triangular hazard symbol.

**CAUTION!**

The signal word CAUTION identifies a potentially hazardous situation, which might result in light injuries. This warning is supplemented by a triangular hazard symbol.

**ATTENTION!**

The signal word ATTENTION identifies a potentially hazardous situation, in which the product or property in the environment may be damaged. This warning is supplemented by a hazard symbol or an exclamation mark.

### 2.2 Intended use

This machine is intended for industrial use; it is only suitable for the permanent marking of hose sleeve of non-hardened metals up to a permissible diameter, see “Technical Data” in Section 3.

Intended purposes include:

- Single user workplace for one person only,
- Manual input and retrieval,
- Operating temperatures between 10 °C and 35 °C,
- Operation in a closed operation room,
- The machine must not be operated by persons not capable of operating the machine without any risk. These may include:
  - persons with physical or mental disabilities,
  - children and persons under age,

## 2 Safety instructions

### 2.3 Product-specific risks

---

- persons with a restricted capability for the operation of machines (e.g. under the influence of drugs, alcohol or narcotics).

Use of the control in compliance with the intended purpose also includes compliance with the instructions in this Operation Manual.

#### Use for other than the intended purpose

Any other use is considered as being not in compliance with the intended purpose, in particular:

- Design modifications of the machine,
- Use in explosive environments,
- misuse of consumables and waste materials.

<b>WARNING!</b>	
	<p><b>Risk for life and health!</b></p> <p>Use not in compliance with the intended purpose imposes risks for life and health. Consequences resulting from use for other than the intended purpose shall be under the sole responsibility of the owner.</p> <ul style="list-style-type: none"><li>• Always use the machine in compliance with its intended purpose.</li></ul>

## 2.3 Product-specific risks

The machine/unit is designed in accordance with the latest state of technology. Nevertheless, the machine/unit may impose risks:

### 2.3.1 Risks posed by mechanical equipment

#### Risk of shearing

When the retractable fork moves, there is a risk of Risk of shearing squeezed between the tool inserts and the work piece.

- Keep sufficient distance to the clamping device.

## 2 Safety instructions

### 2.3 Product-specific risks

---

#### **Risk of squeezing**

When the retractable fork moves, there is a risk of Risk of shearing squeezed between the tool inserts and the work piece.

- Keep sufficient distance to the movable parts of the machine and the tool inserts.

#### **Tilting hazard**

The risk of tilting mainly exists while the machine is being transported.

- Observe the machine's centre of gravity during transport.

## 2.4 Safety

### 2.4.1 Working area

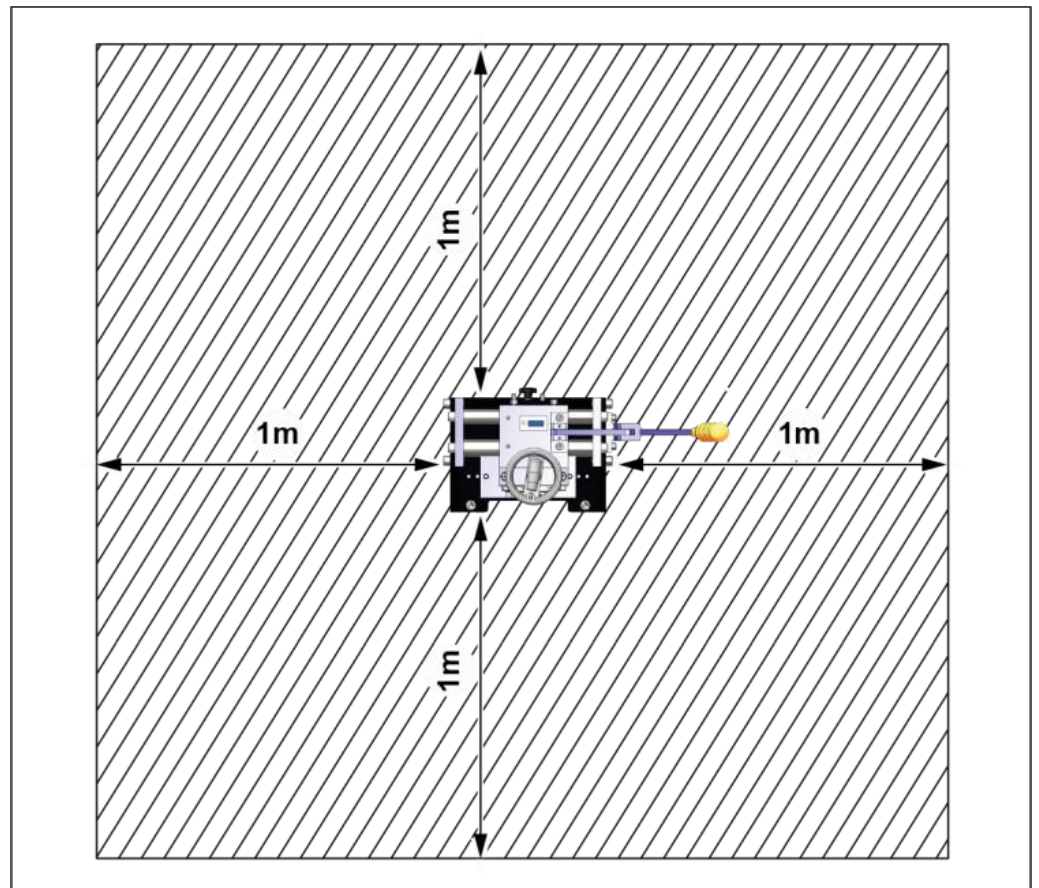

The working area is defined as the area 1 metre all around the machine (shaded).

- Keep the working area free from trip hazards.
- Provide good illumination.



## 2 Safety instructions

### 2.4 Safety

---

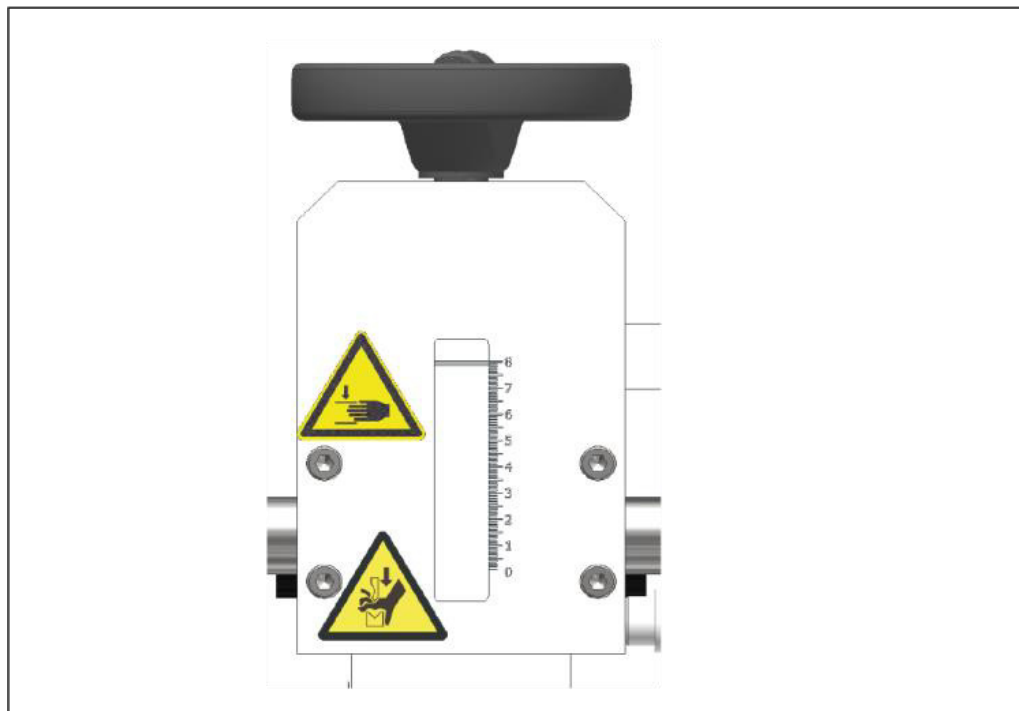
#### 2.4.2 Warning signs on the machine



	<b>Hand injury</b> on the guide carriage
	<b>Risk of squeezing</b> on the steel type holder

Illegible or missing warning signs must immediately be replaced by the operator.

## 3 Machine description

### 3.1 Design and function

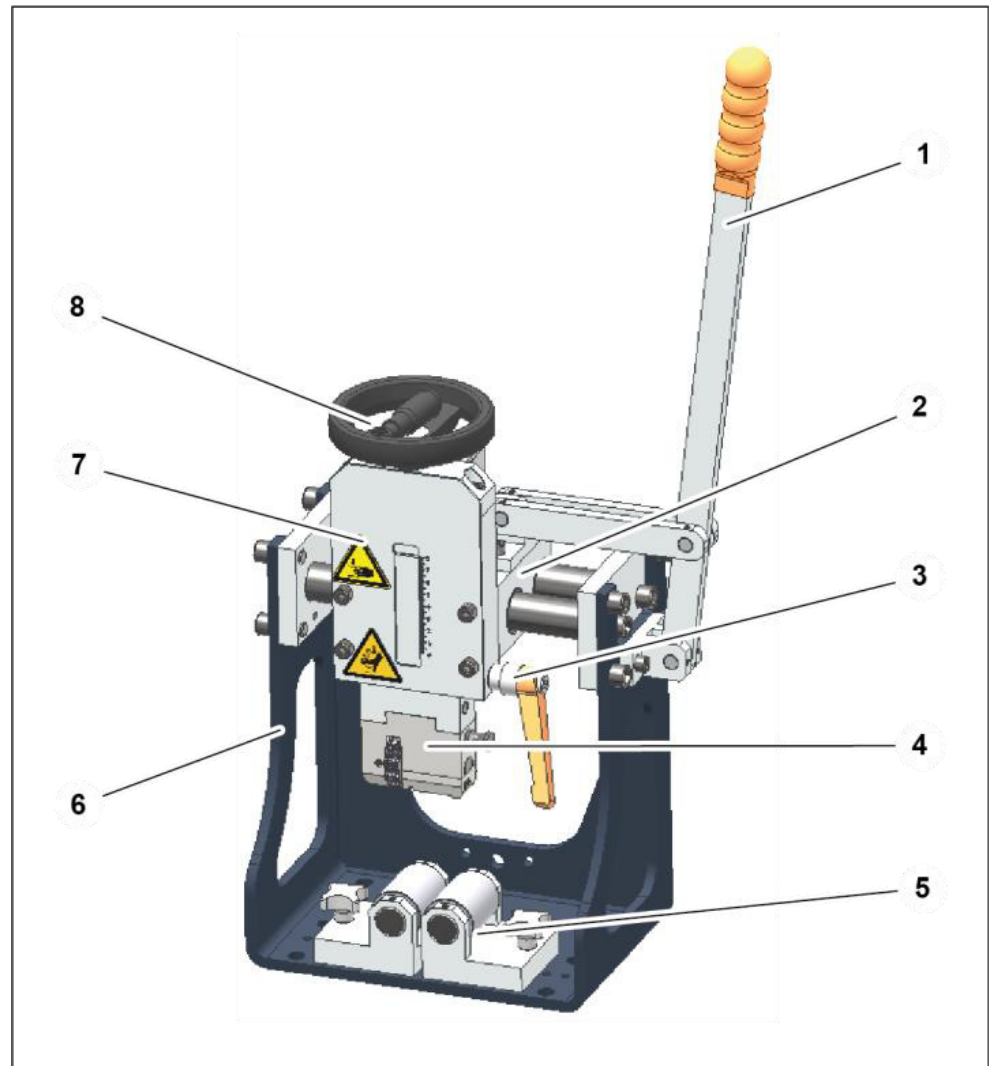

- (1) Operating lever
- (2) Guide carriage
- (3) Clamp lever (accessory)
- (4) Steel type holder
- (5) Bearing block
- (6) Chassis
- (7) Vertical guide
- (8) Hand wheel

## 3 Machine description

### 3.1 Design and function

---

The steel type holder (3) is moved towards the bearing block (4) over the vertical guide (6) by turning the hand wheel (7). As a result, the work piece is fixed on the bearing blocks.

The guide carriage (2) is moved horizontally using the operating lever (1). During embossing, the work piece circumference is rolled against the steel types.

By turning the clamp lever (3) or by using an M12 bolt, the hand wheel (8) and the steel type holder (4) may be fixed in order to provide protection against independent vertical sliding after several embossing processes.

#### **Accessories**

The machine can be fitted with accessories. A list of the available accessories is included in the Annex, Section "Accessories".

## 3 Machine description

### 3.2 Technical data

---

#### 3.2 Technical data

##### Machine

Dimensions L x W x H 272 x 200 x 750 mm

Weight approx. 35 kg

##### Function

Drive unit Manual

Embossing depth ~ 0.5 mm\*

Suitable steel types 30 (depending on type holder)

##### Work piece capacity

Working area Ø 11.5 - 90 mm

##### Workbench

Solid, plane workbench with a carrying capacity of approx. 500 kg

##### We recommend industrial flooring which meets the following structural requirements

Permanent floor loading Approx. 0.07 kg/mm<sup>2</sup>

Floor carrying capacity Min. 2500 kg/m<sup>2</sup>

Floor quality B25

Evenness Max. unevenness 5 mm/m

Inclination max. 5 mm/m



## 3 Machine description

### 3.2 Technical data

---

#### **Ambient conditions**

Ambient temperature                      10 °C – 40 °C

Air humidity                                45 % – 65 %

The \* data are theoretical/computed values, or values measured on a prototype. Actual values may vary slightly, depending on the machine.

## 4 Transport and commissioning

### 4.1 Transport

---

## 4 Transport and commissioning

### 4.1 Transport

The goods should be transported in the original packaging. During transport, the goods must be secured safely within the packaging. All applicable laws and regulations relating to securing loads shall be observed during transport.

The machine can only be transported manually. For machine weight, please refer to "Technical data" in Section 3.

#### **WARNING!**



#### **Danger from falling loads!**

Risk of injury from falling loads.

- Do not stand under suspended loads.

#### **WARNING!**



#### **Danger from increased load weights!**

The weight of the machine is approx. 35 kg.

- Transport the machine with two persons.
- Use transport aids.

1. Lift the machine manually and transfer it to the installation site.

### 4.2 Intermediate storage of machine/unit

If the machine/unit cannot be mounted immediately upon delivery, it must be protected against:

- Contamination,
- Weather influences,
- Mechanical damage.

The machine/unit components may only be stored in closed rooms and under the following conditions:

- temperature between 10°C and 35°C,

## 4 Transport and commissioning

### 4.3 Commissioning

---

- maximum air humidity 80% (non-condensating).

### 4.3 Commissioning

The machine is commissioned by the customer's fitter.

1. Lift the machine manually and place it on the optionally supplied table.

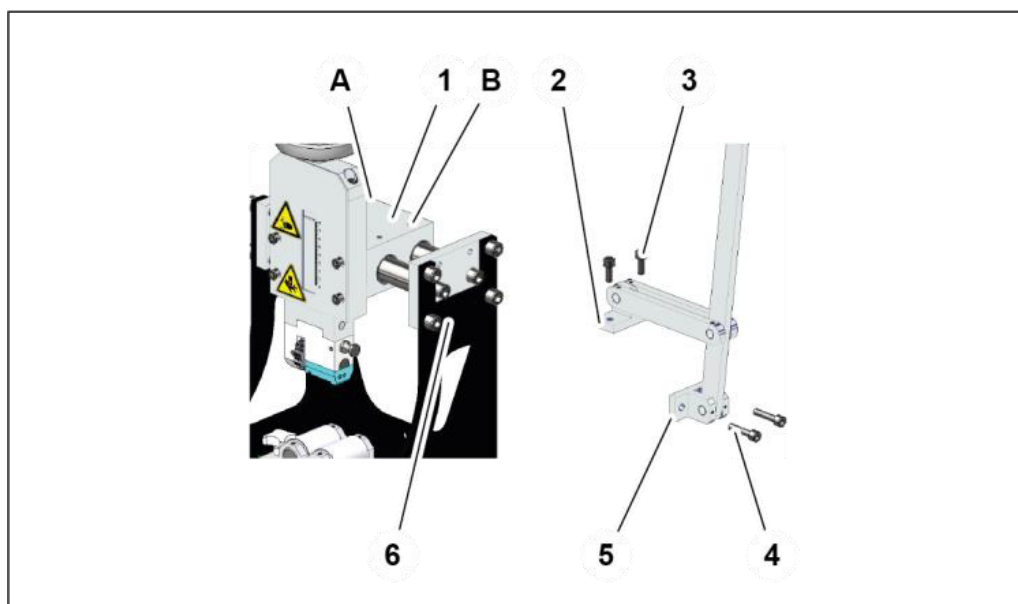

2. Mount the bearing block (2) to the guide carriage (1) using the cylinder bolts (3).



The operating lever may optionally be mounted on the right, position (B), or on the left, Position (A).

## 4 Transport and commissioning

### 4.3 Commissioning

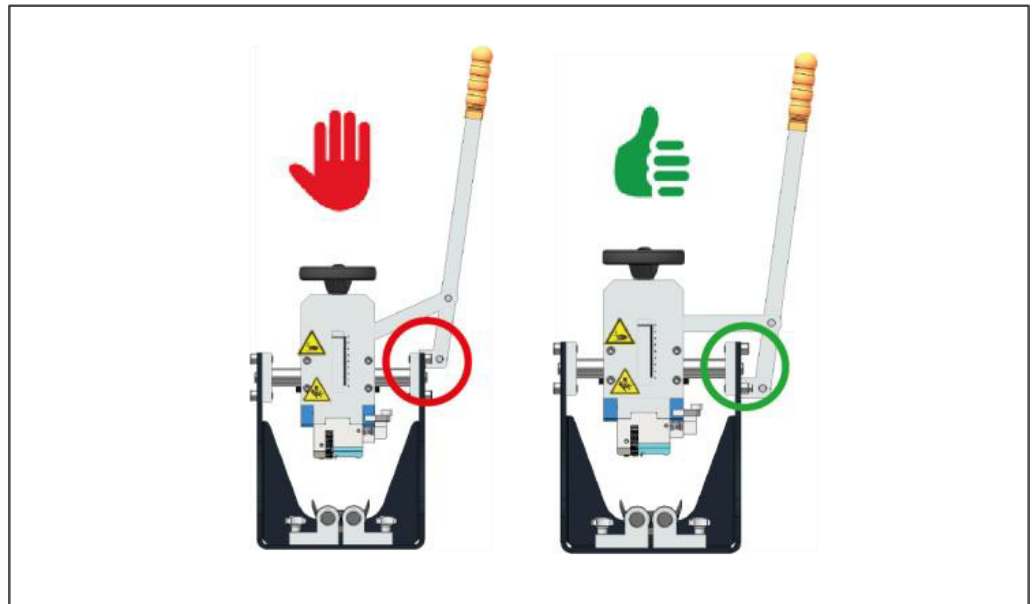

3. Mount the bearing block (5) to the chassis (6) using cylinder bolts (4).

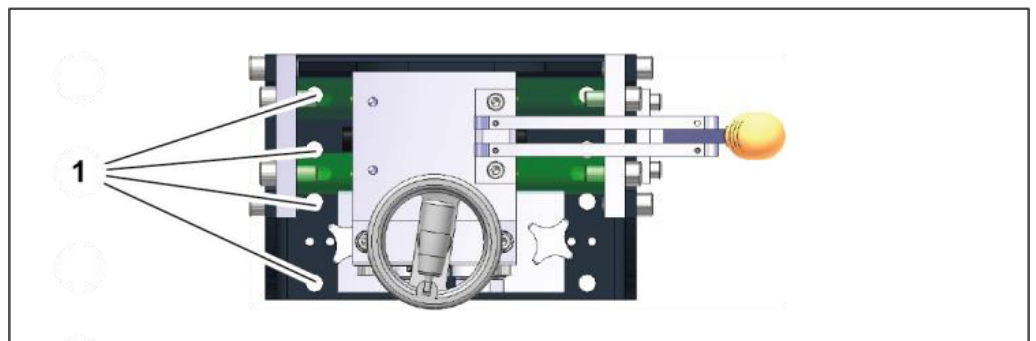

4. Use appropriate bolts to mount the machine on four of the eight holes  $\varnothing 13$  (1) in the machine bench.



Place the machine in a way so that it is easily accessible for maintenance work from all sides.

5. Check the machine for damage.
6. Dismantle the transport securing device on the guide carriage. Cut the cable tie and remove the padding.
7. Train the operating staff and record training sessions in “Declaration of trained staff”, Section 9.

## 4 Transport and commissioning

### 4.3 Commissioning

---

#### WARNING!



#### **Risk of injuries!**

Machine components might loosen during transport. Such components might be flung out during the embossing process. There is a risk of being injured.

- Simulate the embossing process several times without a work piece.
- Check the machine for atypical noise.

## 5 Operation

### 5.1 What you have to observe

---

## 5 Operation

### 5.1 What you have to observe

The operator has received the Operation Manual from the owner, has read and understood it and will observe it.

#### **Before starting and/or re-starting**

- Ensure sufficient illumination of the working area of the machine.

#### **During operation**

- Observe the safety instructions on the machine.
- Make sure that no other persons stay in the working area.
- Use appropriate aids to handle heavy workpiece.
- Each movement of the hand must be observed.
- Eating, drinking and smoking at the workplace is prohibited.
- Wear close-fitting clothes.
- Do not wear watches or jewellery.

## 5 Operation

### 5.2 Embossing the work piece

---

## 5.2 Embossing the work piece

### 5.2.1 Prerequisites

Prerequisites for a correct skiving process:

- Bearing blocks are set to the diameter of the work piece.
- Steel types are mounted correctly in the steel type holder.
- Steel type holder is mounted correctly in the stamp holder.

### 5.2.2 Embossing

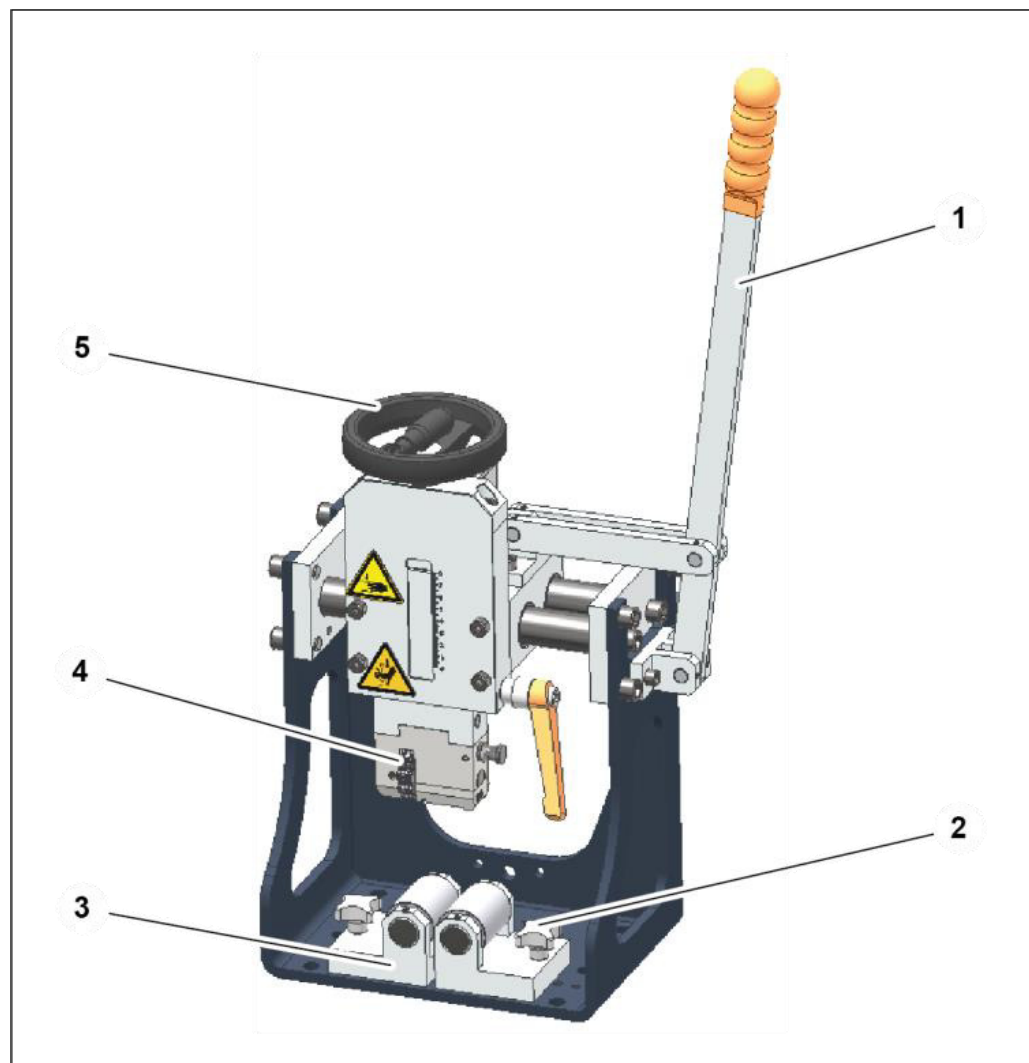

1. Set the bearing blocks (3) to the requested workpiece size - three positions are available.

## 5 Operation

### 5.2 Embossing the work piece

---



The bending pin position and the work piece diameter are matched to each other: Large sleeve diameter = large distance of bearing blocks. Small sleeve diameter = small distance of bearing blocks.

2. Unscrew the star knob screw (2).
3. Displace the bearing blocks (3) to the requested position and secure them using the star knob screw (2).
4. Position the work piece on the bearing blocks (2).
5. Turn the hand wheel (5) until the steel types (4) are in contact with the work piece.
6. Remove the workpiece from the machine.
7. Turn the hand wheel (5) counter-clockwise to the stop by a half-turn.
8. Position the work piece on the bearing blocks (3).
9. Use the operating lever (1).
10. Remove the workpiece from the machine.
11. Check the forming dimension after the first forming process. Correct the embossing depth by turning the hand wheel.



The set value may be read on the scale of the vertical guide to be re-used for identical work pieces later.



## 5 Operation

### 5.2 Embossing the work piece

#### 5.2.3 Embossing with steel type holder, single-row with 4 wheels

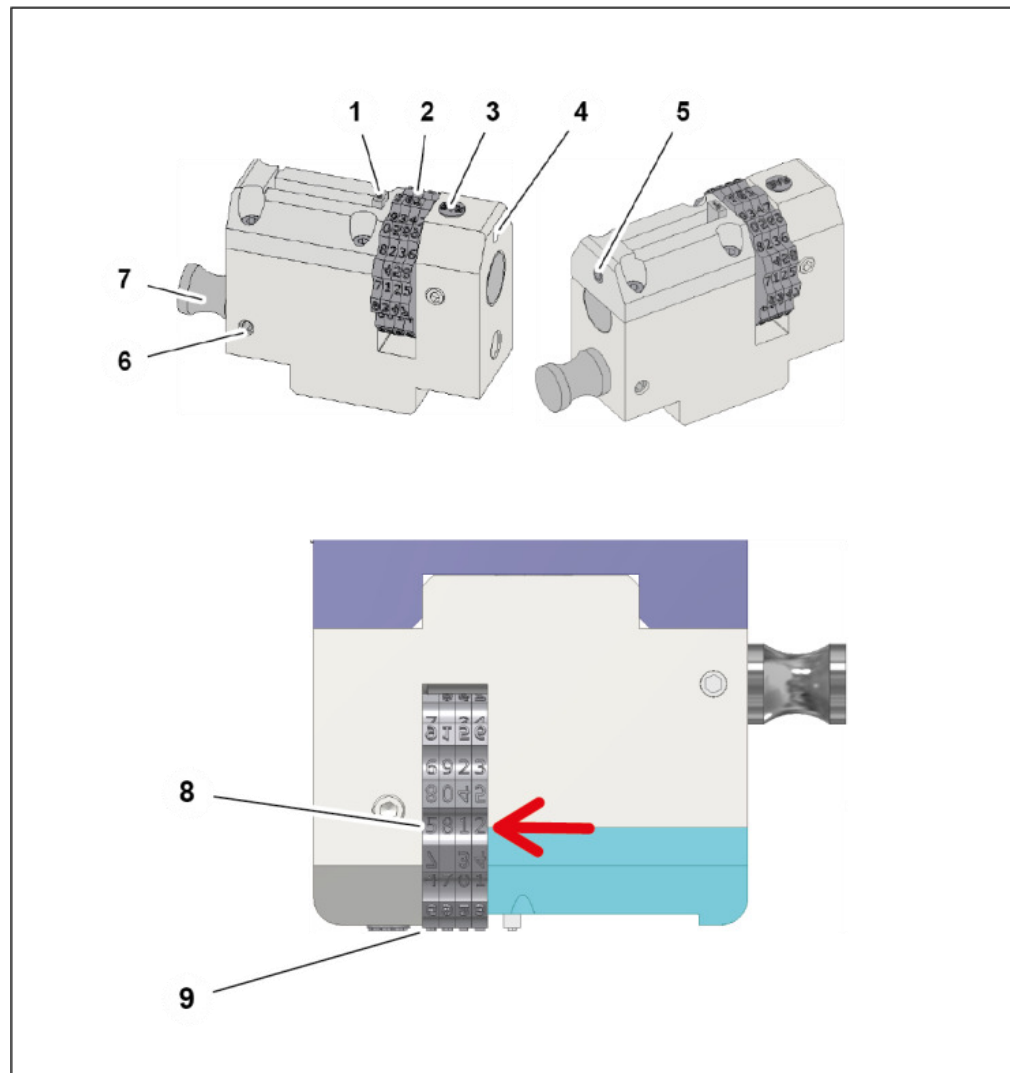

1. Insert steel types (1) in steel type holder. Space types allow a space to be left between the markings.
2. Tighten the clamping screw (5).
3. Loosen the clamping screw (6).
4. Loosen retaining pin (7).
5. Adjust the daisy wheels (2).  
The setting of the type wheels (8) represents the markings to be embossed.
6. Fix the retaining pin (7).
7. Tighten the clamping screw (6).
8. Loosen the clamping screw (4).
9. Insert the block (3).

## 5 Operation

### 5.2 Embossing the work piece

---

10. Tighten the clamping screw (4).



Make sure that clamp has been installed correctly and securely.



Check the correct (non-reversed) arrangement of the types by metallic mirror.

#### 5.2.4 Embossing with steel type holder, double-row without wheels

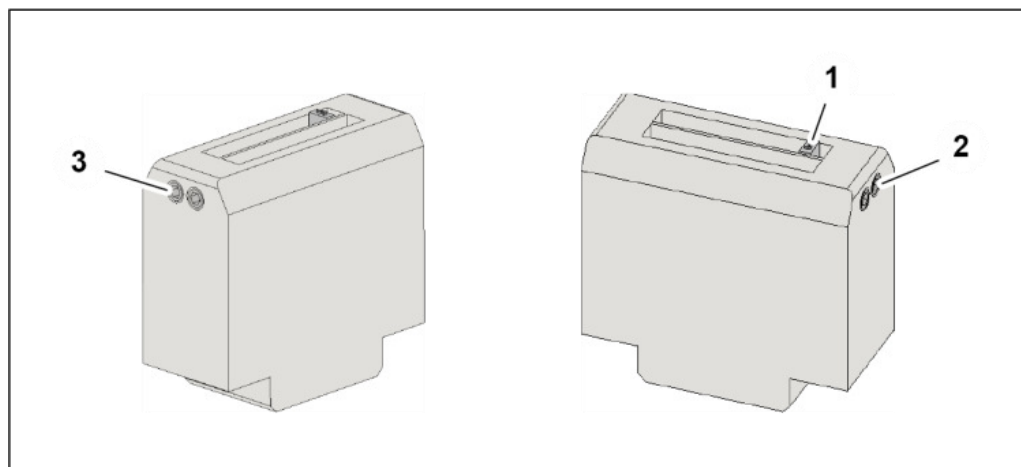

1. Insert steel types (1) in steel type holder. Neutral types allow a space to be left between the markings.
2. Tighten the clamping screws (2).
3. Loosen the clamping screws (3).



Make sure that clamp has been installed correctly and securely.



Check the correct (non-reversed) arrangement of the types.

## 5 Operation

### 5.2 Embossing the work piece

#### 5.2.5 Embossing with steel type holder, single-row with 4 wheels

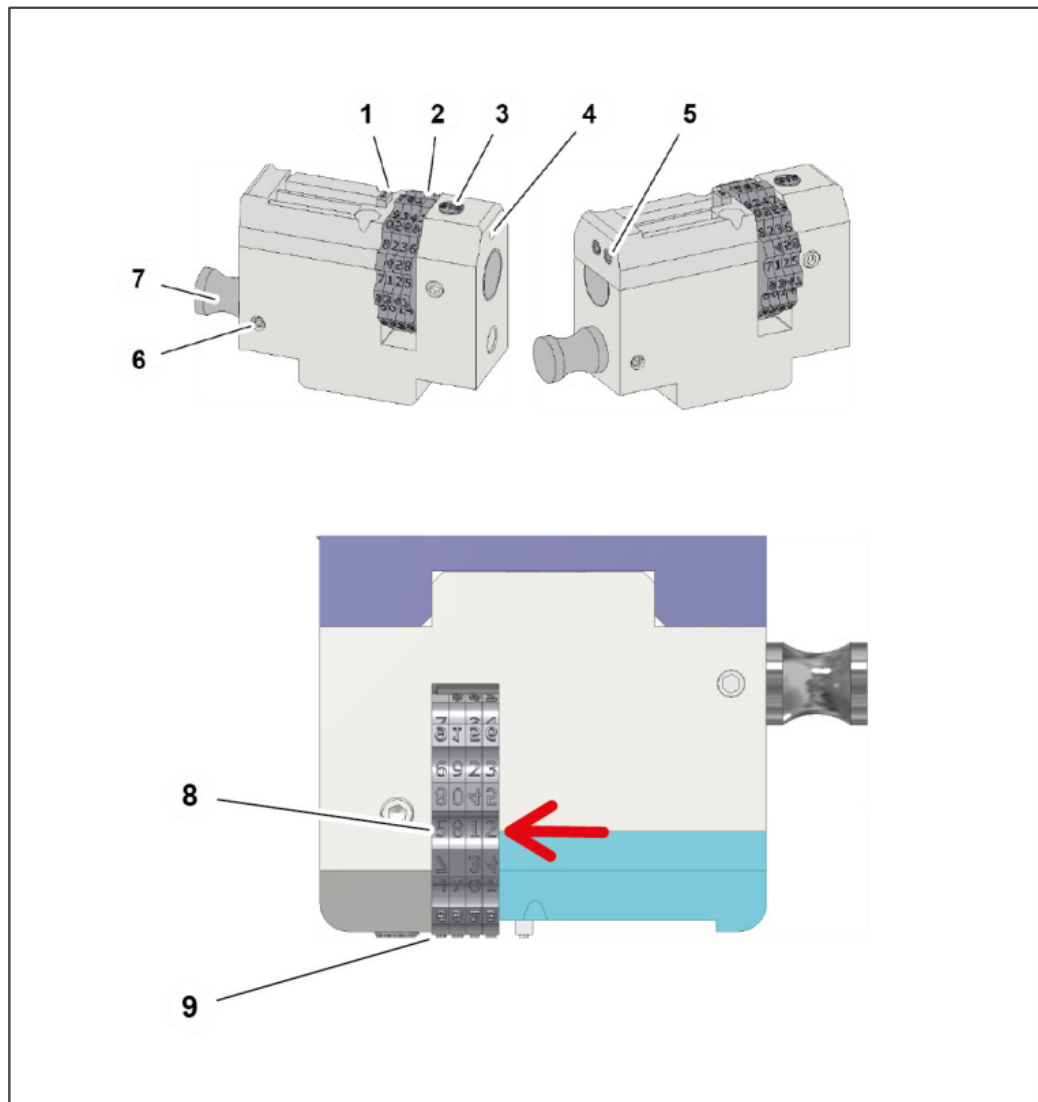

1. Insert steel types (1) in steel type holder. Space types allow a space to be left between the markings.
2. Tighten the clamp levers (5).
3. Loosen the clamping screw (6).
4. Loosen retaining pin (7).
5. Adjust the daisy wheels (2).  
The setting of the type wheels (8) represents the markings to be embossed.
6. Fix the retaining pin (7).
7. Tighten the clamping screw (6).
8. Loosen the clamping screw (4).
9. Insert the block (3).

## 5 Operation

### 5.2 Embossing the work piece

10. Tighten the clamping screw (4).



Make sure that clamp screws have been installed correctly and securely.



Check the correct (non-reversed) arrangement of the types by metallic mirror.

#### 5.2.6 Steel type holder replacement

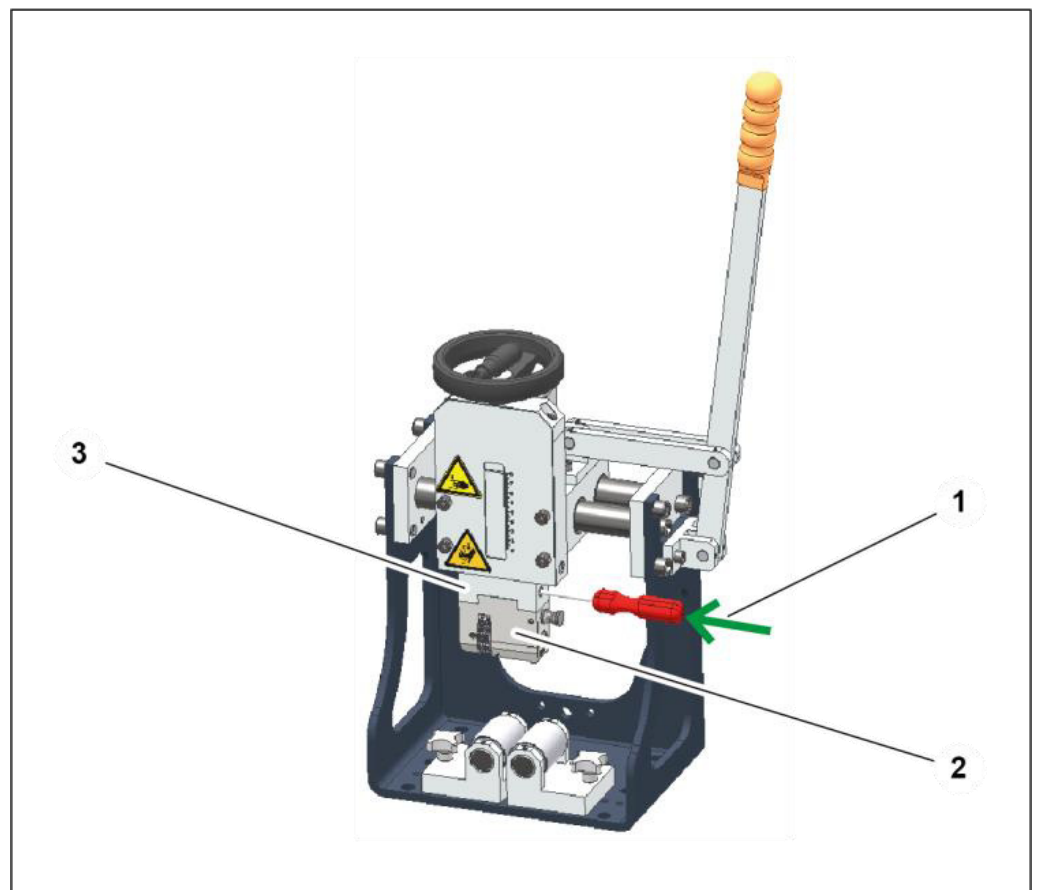

#### Positioning the steel type holders

1. Use the wrench (1) to push the locking pin in the stamp holder (3) to the left and hold it.
2. Use the retaining bolt to insert the steel type holder (2) into the mounting hole.

## 5 Operation

### 5.2 Embossing the work piece

---

3. Remove the die wrench to release the pressure on the locking bolt - the intermediate die is now fixed.

#### **Removing the steel type holder**

1. Hold the steel type holder with one hand.
2. Push the locking pin in the steel type holder (2) with the wrench (1) in the other hand and hold it.
3. Remove the steel type holder.
4. Remove the wrench (1) to relief the pressure on the locking pin.

## 5.3 Cleaning

### ATTENTION!



#### **Risk of damage to machinery!**

If the machine is cleaned with a steam jet or compressed air, dirt and water may ingress in the machine and cause serious damage.

- Do not use a steam jet to clean the device.
- Do not use compressed air to clean the machine.

1. Use a soft cloth to clean the machine.
2. Remove metal abrasion on embossing types and daisy wheels using a brass brush.

## 6 Maintenance

### 6.1 What you have to observe

---

## 6 Maintenance

Regular maintenance will ensure the continuous operation reliability of the machine/unit.

### 6.1 What you have to observe

This section describes activities to be performed by you as the operator at regular intervals to ensure smooth operation of the machine/unit.

- Maintenance work may only be performed by qualified maintenance staff (fitter).
- Repair work on the machine/unit or components may only be performed by appropriately qualified expert staff or UNIFLEX experts!
- Welding, flame-cutting and grinding work on and in the machine/unit and its environment must be approved in advance. There is a risk of fire. The machine/unit must be cleaned from dust and inflammable substances. Adequate ventilation must be ensured.

### 6.2 Maintenance schedule

If not specified otherwise, inspections listed in the maintenance schedule are visual inspection. Replace defective parts immediately.

If you work in 2 shifts, the check frequency has to be doubled. If you work in 3 shifts, you proceed as with 2-shift operation.

Record maintenance work performed in the maintenance log.

Maintenance item	Weekly	Monthly	Every 6 months	Number of years
<b>Machine</b>				
Machine: Check for damage and wear.		X		
Retaining bolt: Check for damage.		X		

## 6 Maintenance

### 6.2 Maintenance schedule

Maintenance item	Weekly	Monthly	Every 6 months	Number of years
Check all bolted connections for secure fitting and retighten if necessary.				1
<b>Safety equipment</b>				
Warning signs on the machine: Check legibility (see "Warning signs on the machine" in Section 2).			X	



The replacement of wear parts must be recorded in the maintenance log!



## 7 Troubleshooting

Error	Cause	Remedy
Guide carriage runs sluggishly	Guide is adjusted incorrectly	Set the backlash on the guide carriage again
	Close the slide bearing	Check slide bearing for wear and replace if necessary
Embossing not sufficient	Embossing depth is set incorrectly	Correct the embossing depth by turning the hand wheel

## 8 Decommissioning, disposal

<b>CAUTION!</b>	
	<p><b>Risk of injuries!</b></p> <p>Contact with consumables, e.g. oils, greases, test media, imposes a risk of injuries for the skin and eyes!</p> <ul style="list-style-type: none"><li>• Observe supplier's protection and safety instructions (see data sheet).</li><li>• Wear personal protection equipment.</li><li>• Do not eat, drink or smoke when handling hydraulic oil.</li><li>• Ensure good ventilation.</li></ul>

### 8.1 Dismantling

This section describes activities to be performed by you as the operator at regular intervals to ensure the safe dismantling of the machine/unit.

- The machine/unit may only be dismantled by entrusted and qualified staff.
- Check the machine/unit for mechanical tension and consider it during dismantling.

### 8.2 Recycling

The machine/unit contains metal, hydraulic hoses, electric cables and electronic components, depending on the type.

As regards disposal, the applicable national environmental protection and waste disposal regulations have to be complied with.

### 8.3 Consumables and waste

Observe applicable national environmental protection and waste disposal regulations.

## 9 Annex

### 8.3 Consumables and waste

---

Return consumables, e.g. oils, greases, test media, to supplier - they are hazardous waste. Also observe the information given on the safety data sheet.

## 9 Annex



Individual machine/unit components may deviate in their features. Please indicate the serial number of the machine for spare part orders.

## 9 Annex

### 9.1 Accessories (retrofitable)

---

#### 9.1 Accessories (retrofitable)

Accessories	Part code
Workbench	TU
Steel type holder, single-row with 4 wheels	508.1001.3
Steel type holder, double-row without wheels	508.1002.3
Steel type holder, single-row with 4 wheels	508.1003.3
Embossing type set	UPTS 100
Counter kit UP 15	508.7001
Sheet metal slide kit UP10	508.7002
Limit stop kit UP 15	508.7003
Die wrench	239.017.4
Clamp lever	300.009

Please contact our Sales Department for ordering optional accessories.

## 9.2 Spare parts list

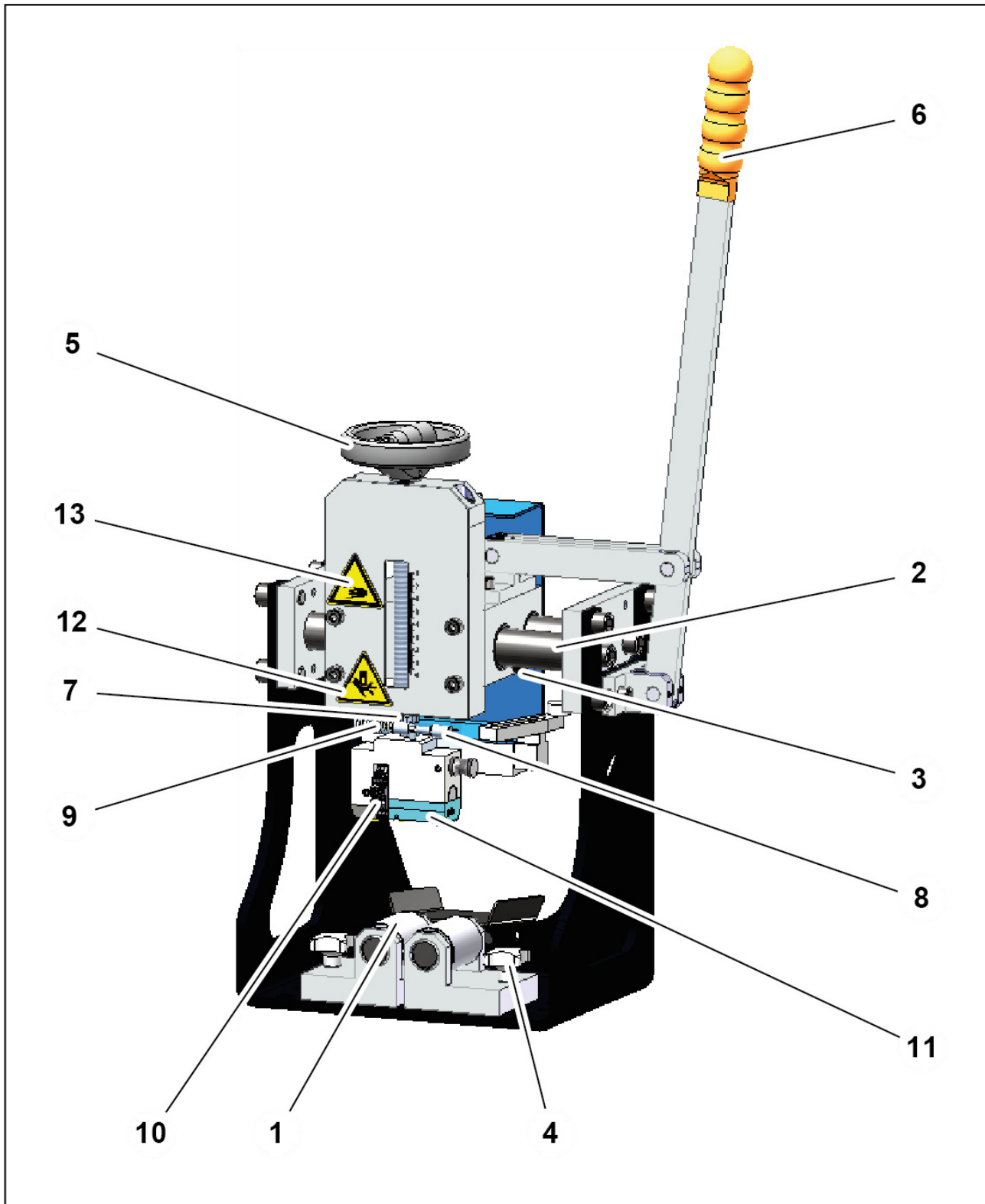

## 9 Annex

### 9.3 Spare parts kit

---

Item	Quantity	Part code	Designation
1	2	508.019.3	Roller
2	1	508.5001	Slide bearing kit
3	2	233.111	Rubber-metal buffer
4	2	232.036	Star knob screw
5	1	504.026	Hand wheel
6	1	777.178	Plastic handle
7	1	232.504.4	Retaining bolt
8	1	235.008.4	Locking bolt
9	1	D-195A-21	Pressure spring
10	4	506.064.4	Type wheel (accessory)
11	1	506.065.4	Block "bar" (accessory)
11	1	506.067.4	Block "PSI" (accessory)
12	1	716.4	Warning of hand injuries sign
13	1	715.4	Squeezing risk warning sign

### 9.3 Spare parts kit

Quantity	Part code	Designation
1	232.504.4	Retaining bolt
1	235.008.4	Locking bolt
1	D-195A-21	Pressure spring
2	232.036	Star knob screw M8x2
1	508.5001	Slide bearing kit

## 9.4 Maintenance log

Slide bearing	Remark	Date	Signature
<input type="checkbox"/>			
<input type="checkbox"/>			
<input type="checkbox"/>			
<input type="checkbox"/>			
<input type="checkbox"/>			
<input type="checkbox"/>			
<input type="checkbox"/>			
<input type="checkbox"/>			
<input type="checkbox"/>			
<input type="checkbox"/>			
<input type="checkbox"/>			
<input type="checkbox"/>			
<input type="checkbox"/>			
<input type="checkbox"/>			
<input type="checkbox"/>			
<input type="checkbox"/>			
<input type="checkbox"/>			
<input type="checkbox"/>			
<input type="checkbox"/>			
<input type="checkbox"/>			
<input type="checkbox"/>			
<input type="checkbox"/>			
<input type="checkbox"/>			
<input type="checkbox"/>			
<input type="checkbox"/>			
<input type="checkbox"/>			
<input type="checkbox"/>			

## 9 Annex

### 9.5 Declaration of qualified staff

---

#### 9.5 Declaration of qualified staff

I herewith declare that I have attended an internal training for the operation of the UNIFLEX machine and have been informed on all safety-related details. In addition I declare that I have read and understood this Operation Manual completely.

--	--	--	--

City

Date

Name

Signature

--	--	--	--

City

Date

Name

Signature

--	--	--	--

City

Date

Name

Signature

--	--	--	--

City

Date

Name

Signature

--	--	--	--

City

Date

Name

Signature

--	--	--	--

City

Date

Name

Signature



## 9 Annex

### 9.5 Declaration of qualified staff

---

## 9 Annex

### 9.5 Declaration of qualified staff

---

## About Danfoss Power Solutions FC

We sincerely appreciate your choice in selecting this product as part of the range of tooling products distributed by Danfoss.

Danfoss hoses, fittings, and tooling provide the ultimate fluid conveyance solutions for a variety of equipment and applications around the world. We proudly engineer to support a sustainable future for tomorrow.

To learn more please visit: <http://www.danfoss.com/en/about-danfoss/our-businesses/power-solutions>

### **Danfoss Power Solutions**

14615 Lone Oak Road  
Eden Prairie, MN 55344, USA  
Phone: 952-937-9800

### **Danfoss Power Solutions II GmbH**

Fluid Conveyance  
Dr. -Reckeweg-Str. 1  
DE-76532 Baden-Baden  
Tel.: +49 7221 6820  
Machine and tooling selection hotline: [FcMachineSupportEMEA@danfoss.com](mailto:FcMachineSupportEMEA@danfoss.com)  
Service and repair Hotline: [FcMachineRepairsEMEA@danfoss.com](mailto:FcMachineRepairsEMEA@danfoss.com)

### **Danfoss Power Solutions (US) Company**

2800 East 13th Street  
Ames, IA 50010, USA  
Phone: +1 515-239-6000

### **Danfoss Power Solutions GmbH & Co.OHG**

Krokamp 35  
D-2439 Neumünster, Germany  
Phone: +49 4321 871 0

### **Danfoss Power Solutions ApS**

Nordborgvej 81  
DK-6430 Nordborg, Denmark  
Phone: +45 7488 2222

### **Danfoss Power Solutions Trade (Shanghai) Co. Ltd.**

Building #22, No 1000 Jin Hai Rd  
Jin Qiao, Pudong New District  
Shanghai, China 201206  
Phone: +86 21 3418 5200w

Thank you for participating in the Danfoss tooling program. We are pleased to offer you high-quality tooling machines manufactured by our trusted partner, Uniflex. These machines are designed to meet the rigorous standards of our industry, ensuring reliability, precision, and efficiency in your operations. We are committed to providing you with the best tools to support your success.

---

Danfoss can accept no responsibility for possible errors in catalogs, brochures, and other printed material. Danfoss reserves the right to alter its products without notice. This also applies to products already on order provided that such alterations can be made without subsequent changes being necessary in specifications already agreed. All trademarks in this material are the property of the respective companies. Danfoss and the Danfoss logotype are trademarks of Danfoss A/S. All rights reserved.