

ENGINEERING
TOMORROW

Danfoss

Manual

Installation and maintenance condensing unit manual

OP-HJZM / HNXM / HRXM / LNYM / LRYM / LJHM



Label

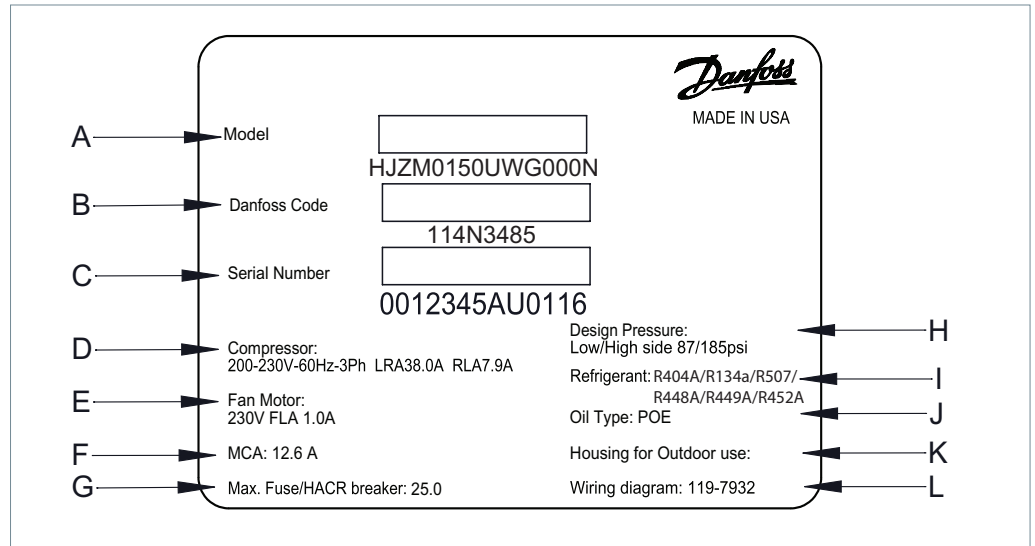

- A:** Model and bar code
- B:** Unit code and bar code
- C:** Serial number and bar code
- D:** Compressor voltage & Locked rotor amps & Rated load amps
- E:** Fan voltage & Full load amps
- F:** Min. Circuit Ampacity
- G:** Max. Fuse size
- H:** Design pressure
- I:** Refrigerant
- J:** Oil type
- K:** Outdoor housing
- L:** Wiring diagram

Picture 1 : Minimum mounting distances

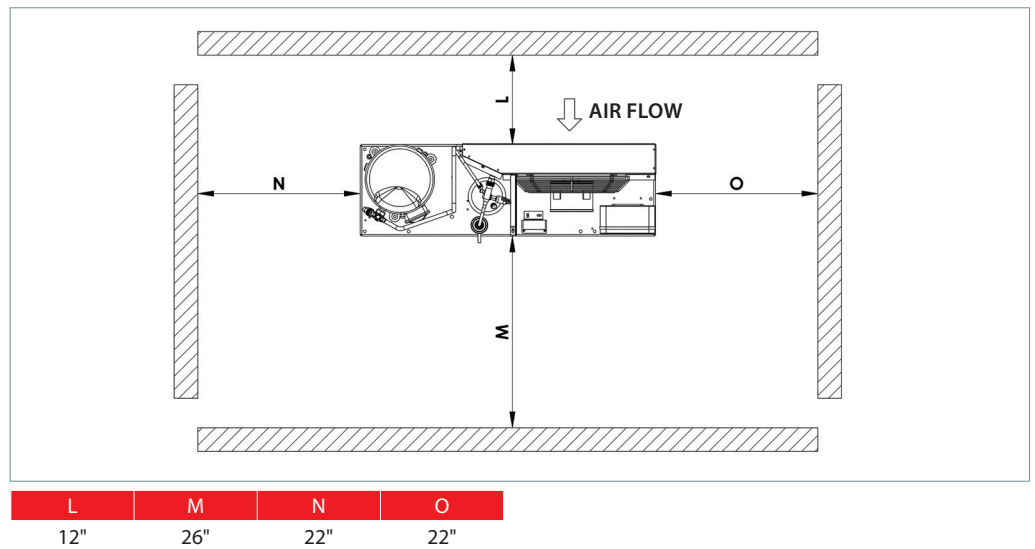

IMPORTANT

- 1 - Installation and maintenance of the condensing unit must be carried out by qualified personnel only. Follow these instructions and best practices on refrigeration engineering during installation, commissioning, maintenance and servicing tasks.
- 2 - The condensing unit must only be used for its designed purposes and within its scope of application.
- 3 - Under all circumstances requirements must be fulfilled.
- 4 - The condensing unit is delivered under nitrogen gas pressure (14.5psi) and hence it cannot be connected as it is; refer to the "Installation" section for further details.
- 5 - The condensing unit must be handled with caution in a vertical position (maximum offset from the vertical: 15°).

Introduction

These instructions pertain to OPTYMA™ condensing units (R404A, R507A, R134a, R448A, R449A, R452A) used for refrigeration systems.

They provide necessary information regarding safety and proper usage of this product.

Handling and storage

It is recommended not to open the packaging before the unit is at the final place for installation.

Handle the unit with care. The packaging allows the use of a forklift or pallet jack for handling. Use appropriate and safe lifting equipment.

- Store and transport the unit in an upright position.
- Store the unit between -30 °F and 120 °F.
- Don't expose the packaging to rain or corrosive atmosphere.
- After unpacking, check that the unit is complete and undamaged.

IMPORTANT

- Unit must be carried out by qualified personnel only.
- Handle the unit with caution always in a vertical position (max. offset from the vertical: 15°).
- Use appropriate / safe lifting equipment. Avoid put pressure against carton box or on any component of the Unit.

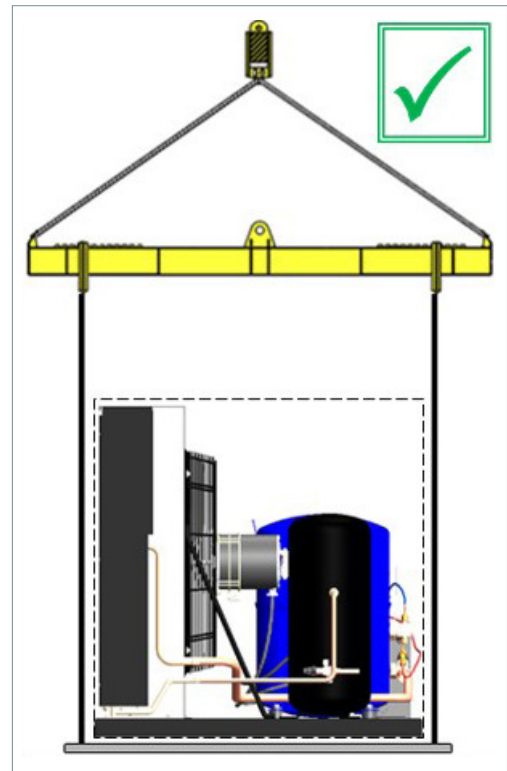
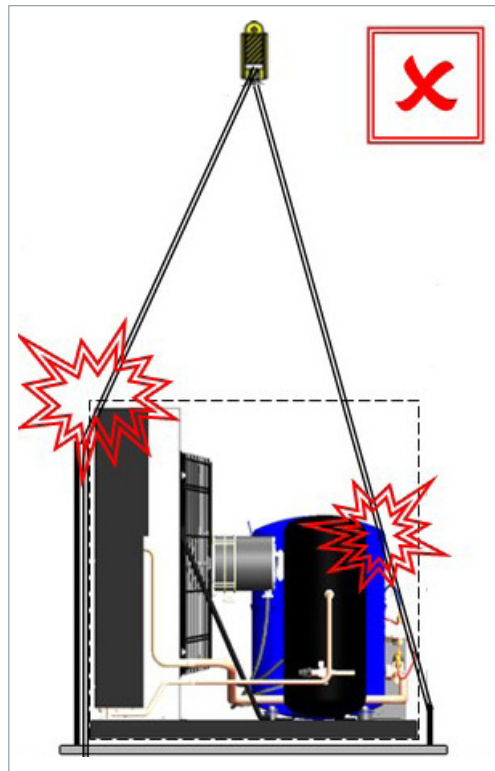

Installation precautions

- ⚠ Do not braze if the condensing unit is under pressure.
- ⚠ Never place the unit in a flammable atmosphere.
- ⚠ Place the unit in such a way that it is not blocking or hindering walking areas, doors, windows or similar.
- Ensure adequate space around the unit for air circulation and to open doors. Refer to picture 1 for minimal values of distance to walls.
- Avoid installing the unit in locations which are daily exposed to direct sunshine for longer periods.
- Avoid installing the unit in aggressive and/or dusty environments.
- Ensure a foundation with horizontal surface (less than 3° slope), strong and stable enough to carry the entire unit weight and to eliminate vibrations and interference.
- The unit ambient temperature may not exceed 120 °F during off-cycle.
- Ensure that the power supply corresponds to the unit characteristics (see nameplate).
- Use clean and dehydrated refrigeration-grade copper tubes and silver alloy brazing material.
- Use clean and dehydrated system components.
- The suction piping connected to the compressor must be flexible in 3 dimensions to dampen vibrations. Furthermore piping has to be done in such a way that oil return for the compressor is ensured and the risk of liquid slug over in compressor is eliminated.

Installation

- The unit must be securely installed on a stable and rigid support, and fix from the beginning.
- It is recommended to install the unit on rubber grommets or vibration dampers (not supplied).
- Slowly release the nitrogen holding charge through the Schraeder port.
- Connect the unit to the system as soon as possible to avoid oil contamination from ambient moisture.
- Avoid material entering into the system while cutting tubes. Never drill holes where burrs cannot be removed.
- Braze with great care using state-of-the-art techniques and vent piping with nitrogen gas flow.
- Connect the required safety and control devices. Remove the internal valve when using the Schraeder port for this.
- It is recommended to insulate the suction pipe up to the compressor inlet with 3/4" mm thick insulation.

Fan speed controller

ADJUSTING

(Fig.3)

Turn the range

Catalog No.	1 Turn
XGE-4*	Approx, 22psi

Adjusting screw to clockwise (+) for increasing the setting value, and to counterclockwise (-) for decreasing the setting value.

(Please use the right chart as reference for adjusting.)

CAUTION

- Do not move the screw other than the Range Adjusting Screw.
- Do not apply torque that exceeds 0.35 Nm for adjusting screw. Otherwise it may damage part of resin case. Then range adjustment may not be possible.

OPERATION CHECK

Install and calibrate the product correctly and the check its operation to confirm correct function of the whole system.

CAUTION

- It can not be used for ammonia refrigeration system.
- This product is not available for the system which apply pressure more than 681psi (47bar) because the rated maximum working pressure of this product is 681psi (47bar) if the pressure more than the rated maximum working pressure is applied to this product, it causes transformation of characteristics or the destruction. Operation will become unstable when using other than sine waves for the power supply. In this case, proper control may not be achieved.
- To ensure stable operation, sine wave AC power supply must also be stable.

Factory Set	F.V.S Setting psi(bar)		E.P.B. psi (bar)
	Min.	Max.	
276 (19)	145 (10)	363 (25)	Fixed 87 (6)

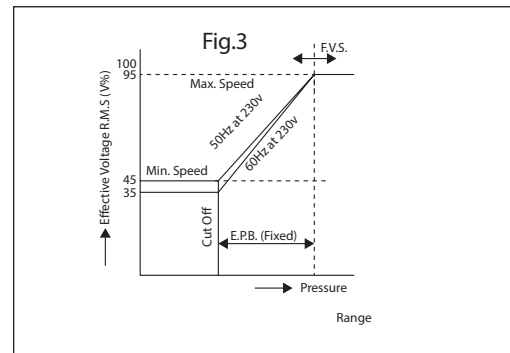

F.V.S.: Full Voltage Set point
The pressure at which the control delivers 95% output effective voltage. (R.M.S.(V%))
E.P.B.: Effective Proportional Band

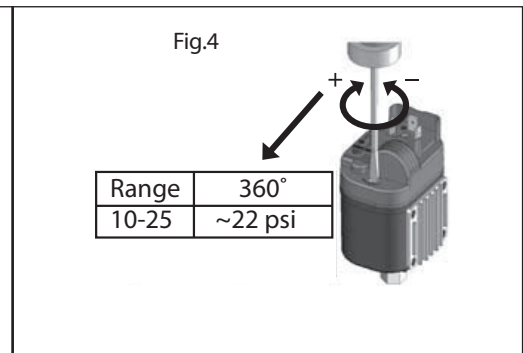

The decrease in pressure below the calibration set point required to transmit a 45% of effective voltage. (R.M.S.(V%))

Fan speed controller for low ambient

For low ambient temperature the fan speed controller is insulated, for high ambient temperature it is recommended to remove it.

CAUTION

If the insulation is replaced ensure does not cover any part of the heatsink.

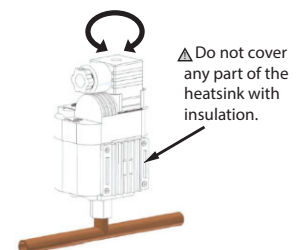

Low ambient kit

Condensing units that can operate at low ambient temperature -13°F with different components working and operating correctly for those temperatures, a head pressure control valve is installed between the compressor discharge and the receiver to bypass the condenser. At low ambient temperature, a receiver heater is added and insulated so that the pressure does not drop and it is maintained. A check valve must be

installed between the condenser and the receiver, as well as low and high pressure switches to be able to bypass only the low pressure switch. It includes a timer to start depending on the compressor pressure and a thermostat to turn on or off if the temperature is exceeded. It is also added to the insulation of pipes, receiver and the FSC to work at low temperatures.

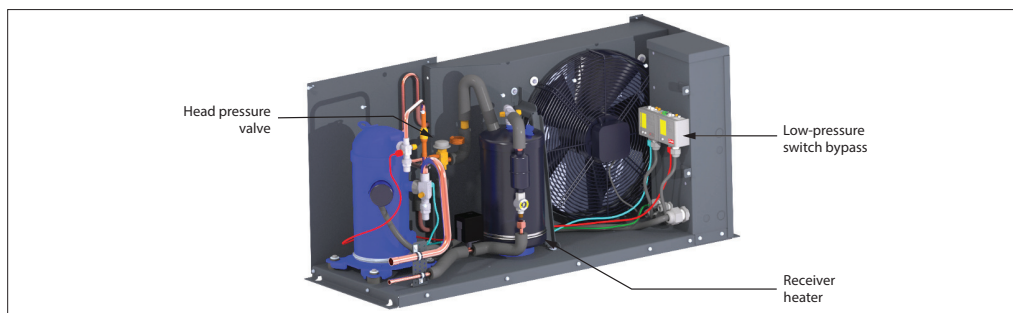

Head pressure valve

- Connect as shown in figure 1 so that I have correct operation.
- Pressure control valves have a brass body with copper connections. These valves are nonadjustable. They perform the function of limiting flow of refrigerant from the condenser and at the same time regulate the flow of hot gas around the condenser to the receiver during low ambient conditions, so as to keep the refrigerant in the liquid line at proper pressure.

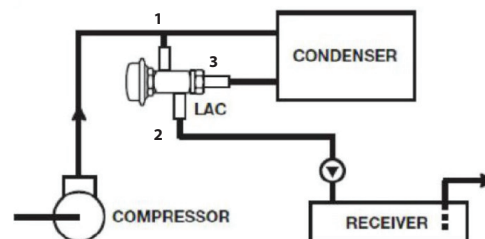

Time delay relay / KP (Low / High)

- Working range from 0.1s to 120s, but settings can be modified to adjust depending on need as show in figure 2.
- Ambient temperature working range -20 + 60°C.
- Follow up the wiring diagram to check the connections.
- For low ambient startup, the unit is equipped with a low-pressure switch time delay bypass. The factory time delay is 60s and can be adjusted using the rotary switch if it is required.
- Connect as shown in figure 4 so that I have correct operation with the electrical box.

CAUTION
Is not recommended to maintain the bypass for than 120 seconds this is to avoid functional or mechanical damage in the unit.

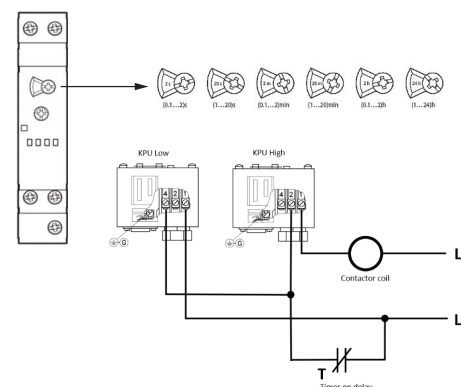

Panel thermostat / Receiver heater

- Ambient temperature range -25 + 60°C as show in figure 3.
- When the temperature on the panel drops below the set (minimum) temperature, it will close the contact, demanding heat. The contact opens when the set temperature is exceeded. Open or close of the functionality of the thermostat depending the temperature in the receiver.
- Follow up the wiring diagram to check the connections.
- The condensing unit is provided with a heater in the receiver to operate during low ambient temperature conditions. This heater is controlled by an ambient thermostat located inside the electrical box. The factory setting is 0°C, however, the end user can modify this value if it is required.

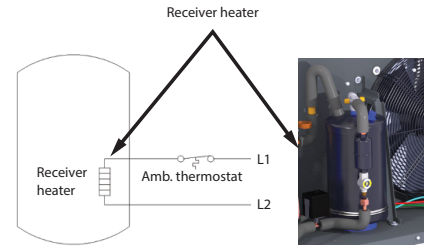
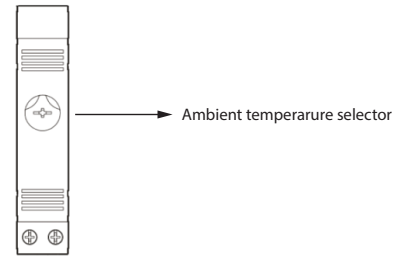

Insulation for low ambient

Piping Insulation / Receiver

To prevent the passage of heat, electricity, or sound by surrounding the area of concern with a non-conductive material. Thermal insulation prevents the transfer of heat because it is not a good conductor (nonconductive). There are many other technical aspects about the performance characteristics of thermal insulation, however, this post will focus on the purpose, reasons to

insulate pipes, and insulation material selection.

Recommendations so that you can only work correctly in low ambient temperatures.

- Must be used pipe insulation as show in the figure 5 on the next tubings and receiver.

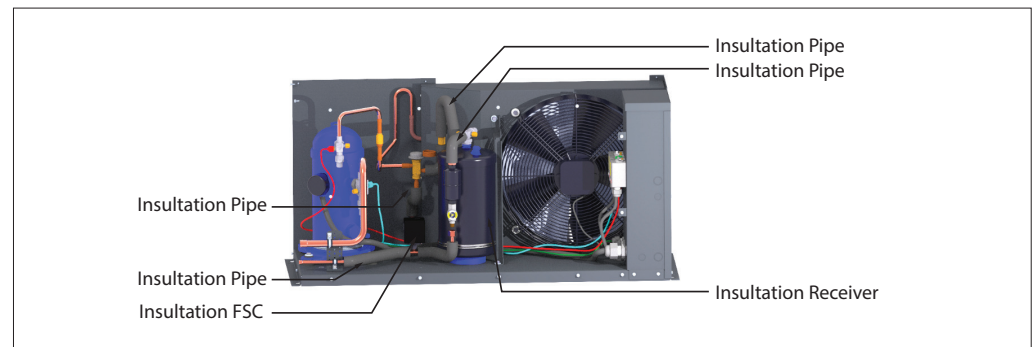

Problem	Possible cause	Confirmation method/Remarks	
Fan motor doesn't rotate, or rotates at full speed	"F.V.S. pressure setting is inadequate"	<p>Check the operation of the fan motor.</p> <ul style="list-style-type: none"> • Pressure setting value may be too high if the fan motor rotates continuously at low speed or stops. => Turn the F.V.S. pressure adjustment screw in (-) direction to set the F.V.S. pressure lower. • Pressure setting value may be too low if the fan motor rotates continuously at full speed. => Turn the F.V.S. pressure adjustment screw in (+) direction to set the F.V.S. pressure higher. <p>Note:</p> <ul style="list-style-type: none"> - In the event that the F. V. S. pressure setting value is lost (for XGE-4*), rotate the pressure setting screw fully toward the (-) symbol, then rotate it 9 times*1 towards the (+) symbol. This should return the F.V.S. pressure setting value to around the factory standard setting value of 1.9 MPa. - Always conduct a test run after changing the setting to confirm the system operates correctly. 	
	PCB was damaged by drop impact	If voltage output cannot be obtained, the internal ceramic PCB may be damaged.	
	Overcurrent was applied	<p>Check if the rated value of the fan motor is within tolerance. => Max. 3A (or 4A conditionally)</p> <ul style="list-style-type: none"> • Check if a load is restricting the fan motor rotation. (Such as snow or freezing.) • Check if a line-to-line short circuit is detected at a connection point of the fan motor. • It is recommended to protect the circuit with a thermal relay or circuit protector. <p>Note: Make sure to remove the cause of burn-out before conducting a test run. Otherwise, burn-out may occur again.</p>	
	Surge voltage was applied	Check if a lightning surge or similar occurred or not.	
	PCB burn-out		<p>Burn-out may be caused by water leakage due to an improperly fitted plug. Check the following items to find any problems with the fitting.</p> <ul style="list-style-type: none"> • Is it tightened to the prescribed torque? • Is the plug fitted with the attached gasket? • Is there a gap between the plug and body?
			<p>When a screw other than attached one is used, the body may be damaged allowing water to leak inside, causing burn-out. Do not use screws other than those attached.</p>
			<p>Burn-out of PCB may be caused by water leaking from the damaged part of the body.</p>
Control is unstable.		<p>In particular, check the connection of the pressure coupling for any leakage. Leakage may occur when copper gasket is not used or misaligned.</p>	
		<p>Check the pressure introduction position</p> <ul style="list-style-type: none"> • Receiver valve fully opened • Filter drier clogged off, • Shreader core press down. <p>It is recommended to detect the pressure from the exit side of condenser.</p>	
Cannot fix the plug	Plug fitting screw stripping	Screws may become stripped when they are tightened with a torque greater than the prescribed value. Please tighten with the prescribed torque.	

Fan speed controller bypass

(If FSC fails, it is possible to run the fan motor full speed)

1. Disconnect the condensing unit from power supply.
2. Remove wire 1 from FSC.
3. Remove wire 2 from FSC.

4. Connect both wires together.
5. Make sure the connection is well insulated and not exposed to rain or in contact with metallic parts.
6. Connect the condensing unit back to power supply.

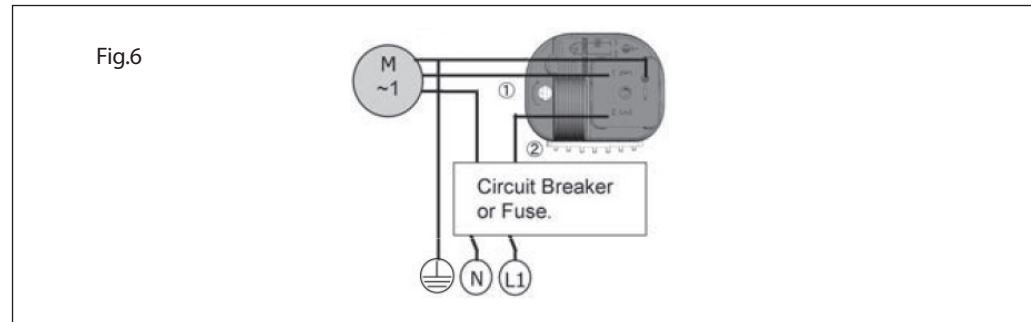

Leak detection

- ⚠ Never pressurize the circuit with oxygen or dry air. This could cause fire or explosions.
- Do not use dye for leak detection.
- Perform a leak detection test on the complete system.

- The maximum test pressure is 465psi.
- When a leak is discovered, repair the leak and repeat the leak detection test.

Vacuum dehydration

- Never use the compressor to evacuate the system.
- Connect a vacuum pump to both the LP and HP sides.

- Pull down the system under a vacuum of 500 μm Hg (9.7psi) absolute.
- Do not use an ohmmeter nor apply power to the compressor while it is under vacuum as this may cause internal damage.

Electrical connections

- Switch off the system and isolate the main power supply.
- Ensure that power supply cannot be switched on during installation.
- All electrical components must be selected as per local standards and unit requirements.
- Refer to wiring diagram for electrical connections details.
- Ensure that the power supply corresponds to the unit characteristics and that the power supply is stable (nominal voltage $\pm 10\%$ and nominal frequency $\pm 2.5\text{ Hz}$).
- Dimension the power supply cables according to unit data for voltage and current.
- Protect the power supply and ensure correct earthing.

- Make the power supply according to local standards and legal requirements.
- The unit includes high and low-pressure switches which, when activated, cut the power supply to the compressor. Parameters for high and low-pressure cut-outs are to be adjusted by the installer, depending on the compressor model, refrigerant and application. For units with a 3-phase scroll compressor, correct phase sequence for compressor rotation direction shall be observed.
- Determine the phase sequence by using a phase meter to establish the phase order of line phases L1, L2 and L3.
- Connect line phases L1, L2 and L3 to main switch terminals T1, T2 and T3, respectively.

Filling the system

- Wear protective stuff like goggles and protective gloves.
- Never start the compressor under vacuum. Keep the compressor switched off.
- Before charging the refrigerant, verify that the oil level is visible in the oil sight glass and between 25% to 75% full.
- Use only the refrigerant for which the unit is designed for.
- Fill the refrigerant in liquid phase into the condenser or liquid receiver. Ensure a slow charging of the system to 58 - 70psi for R404A/ R507A or R22, and approx. 30psi for R134a.
- Do not put liquid refrigerant through the suction line.
- It is not allow to mix additives with the oil and/or refrigerant.
- The remaining charge is done until the installation has reached a level of stable nominal condition during operation.
- Never leave the filling cylinder connected to the circuit.

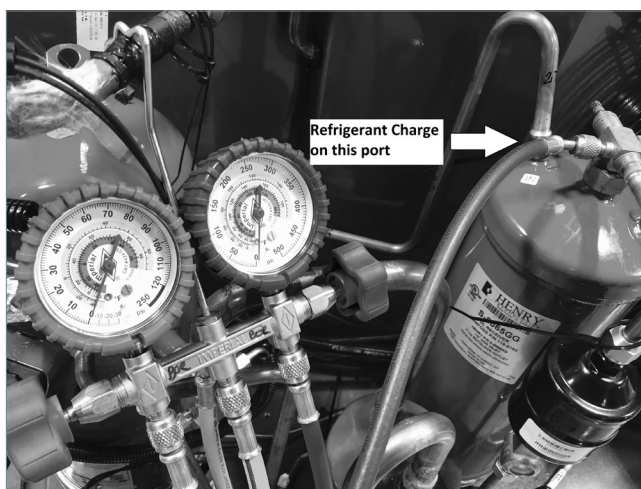

Warning – Charging from suction valve during start up can damage the compressor.

Verification before commissioning

- ▲ Use safety devices (such as safety pressure switches and mechanical relief valves) in compliance with both generally and locally applicable regulations and safety standards. Make sure that the devices are operational and properly set.
- ▲ Check that the settings of high-pressure switches and relief valves don't exceed the maximum service pressure of any system component.
- Verify that all electrical connections are properly fastened and in compliance with local regulations.
- When a crankcase heater is required, it must be energized at least 12 hours before initial start-up and start-up after prolonged shut-down or belt type crankcase heaters.

Start-up

- Never start the unit when no refrigerant is charged.
- All service valves must be in the open position.
- Check compliance between unit and power supply.
- Check that the crankcase heater is working.
- Check that the fan can rotate freely.
- Check that the protection sheet has been removed from the backside of condenser.
- Balance the HP/LP pressure.
- Energize the unit. It must start promptly. If the compressor does not start, check wiring conformity, voltage on terminals and sequence phase.
- Eventual reverse rotation of a 3-phase compressor can be detected by the following phenomena: unit doesn't start, the compressor doesn't build up pressure, it has abnormally high sound level and abnormally low power consumption. In such case, shut down the unit immediately and connect the phases to their proper terminals.
- If the rotation direction is correct, the low-pressure gauge shall show a declining pressure and the high-pressure gauge shall show an increasing pressure.

Manual

Installation & Maintenance

Checks with running unit

- Check the fan rotation direction. Air must flow from the condenser towards the fan.
- Check current draw and voltage.
- Check suction superheat to reduce risk of slugging.
- When a sight glass is provided, observe the oil level at start and during operation to confirm that the oil level remains visible.
- Respect the operating limits.
- Check all tubes for abnormal vibration. Movements in excess of 0.06in require corrective measures, such as tube brackets.
- When needed, additional refrigerant in the liquid phase may be added in the low-pressure side as far as possible from the compressor. The compressor must be operating during this process.
- Do not overcharge the system.
- Never release refrigerant to the atmosphere.
- Before leaving the installation site, carry out a general installation inspection regarding cleanliness, noise and leak detection.
- Record type and amount of refrigerant charge, as well as operating conditions as a reference for future inspections.

Maintenance

- △ Always switch off the unit at main switch before removing the fan panel.
 - △ Internal pressures and surface temperatures are dangerous and may cause permanent injury.
 - △ Maintenance operators and installers require appropriate skills and tools. Tubing temperature may exceed 200 °F and therefore cause severe burns.
 - △ Ensure that periodic service inspections to ensure system reliability and as required by local regulations are performed.
- To prevent system related problems, following periodic maintenance is recommended:
- Verify that safety devices are operational and properly set.
 - Ensure that the system is leak tight.
 - Check the compressor current draw.
 - Confirm that the system is operating in a way consistent with previous maintenance records and ambient conditions.
 - Check that all electrical connections are still adequately fastened.
 - Keep the unit clean and verify the absence of rust and oxidation on the unit components, tubes and electrical connections.
- The condenser must be checked at least once a year for clogging and be cleaned if deemed necessary. Access to the internal side of the condenser takes place through the fan panel. Microchannel coils tend to accumulate dirt on the surface rather than inside, which makes them easier to clean than fin-&-tube coils.
- Switch off the unit at main switch before removing any panel from the condensing unit.
 - Remove surface dirt, leaves, fibers, etc. with a vacuum cleaner, equipped with a brush or other soft attachment. Alternatively, blow compressed air through the coil from the inside out, and brush with a soft bristle. Do not use a wire brush. Do not impact or scrape the coil with the vacuum tube or air nozzle.
- If the refrigerant system has been opened, the system has to be flushed with dry air or nitrogen to remove moisture and a new filter drier has to be installed. If evacuation of refrigerant has to be done, it shall be done in such a way that no refrigerant can escape to the environment.

Maintenance

- Always transmit the model number and serial number with any claim filed regarding this product.
- The product warranty may be void in following cases:
- Absence of nameplate.
 - External modifications; in particular, drilling, welding, broken feet and shock marks.
 - Compressor opened or returned unsealed.
 - Rust, water or leak detection dye inside the compressor.
 - Use of a refrigerant or lubricant not approved by Danfoss.
 - Any deviation from recommended instructions pertaining to installation, application or maintenance.
 - Use in mobile applications.
 - Use in explosive atmospheric environment.
 - No model number or serial number transmitted with the warranty claim.

Disposal



Danfoss recommends that condensing units and oil should be recycled by a suitable company at its site.

MBP

Unit	Dimensions [in]					
	Fig.	Height H [in]	Width W [in]	Length D [in]	Suction line	Liquid line
HJZM0150	1	19.5	43.5	13.4	5/8"	3/8"
HNXM0200	1	22.4	47.4	16.5	7/8"	1/2"
HNXM0250	1	22.4	47.4	16.5	7/8"	1/2"
HNXM0300	1	22.4	47.4	16.5	7/8"	1/2"
HNXM0350	1	28.2	47.4	16.5	7/8"	1/2"
HNXM0400	1	28.2	47.4	16.5	7/8"	1/2"
HRXM0500	2	28.8	49.4	31.5	7/8"	1/2"
HRXM0600	2	28.8	49.4	31.5	7/8"	1/2"
HRXM0700	2	28.8	49.4	31.5	7/8"	1/2"
HRXM0750	2	39.1	61.2	31.5	1 1/8"	5/8"
HRXM1000	2	39.1	61.2	31.5	1 1/8"	5/8"

LBP

Unit	Dimensions [in]					
	Fig.	Height H [in]	Width W [in]	Length D [in]	Suction line	Liquid line
LJHM0150	1	19.5	43.5	13.4	5/8"	3/8"
LJHM0200	1	19.5	43.5	13.4	5/8"	3/8"
LN YM0400	1	28.2	47.4	16.5	7/8"	1/2"
LN YM0500	1	28.2	47.4	16.5	7/8"	1/2"
LN YM0600	1	28.2	47.4	16.5	7/8"	1/2"
LRYM0800	2	28.8	49.4	31.5	1 1/8"	1/2"

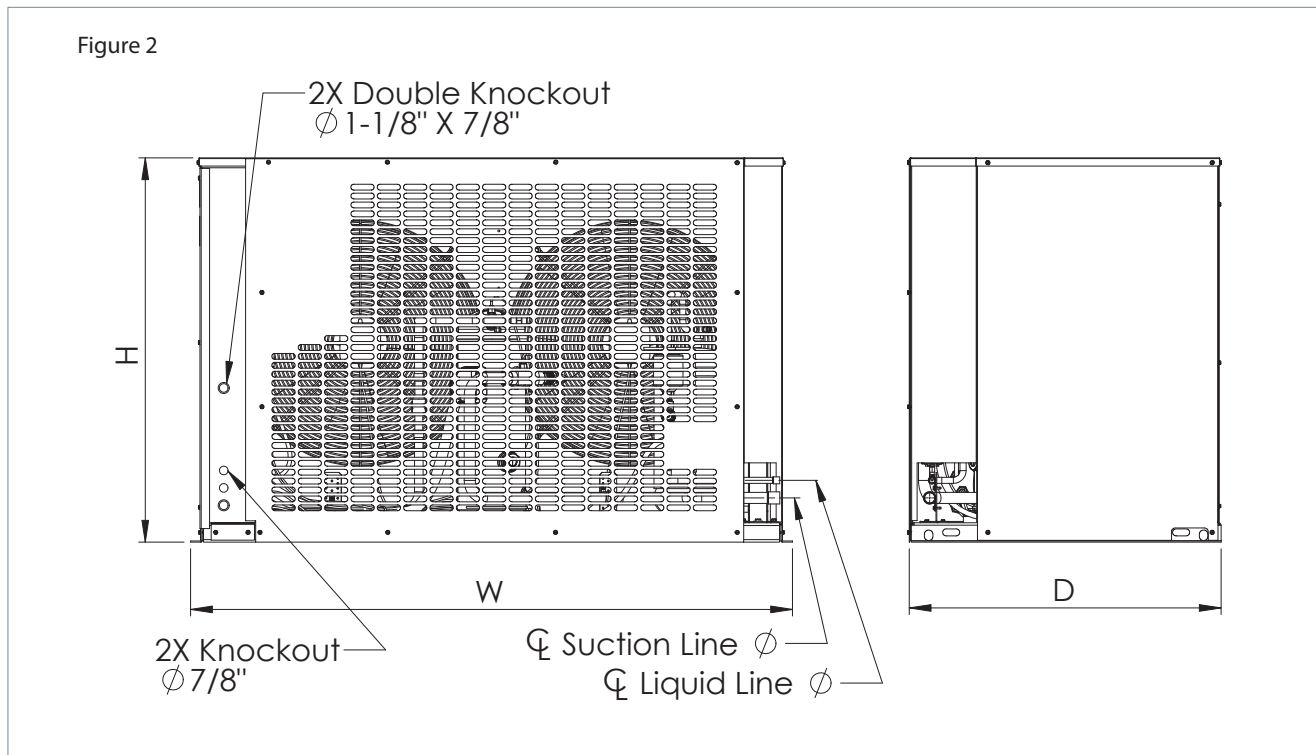
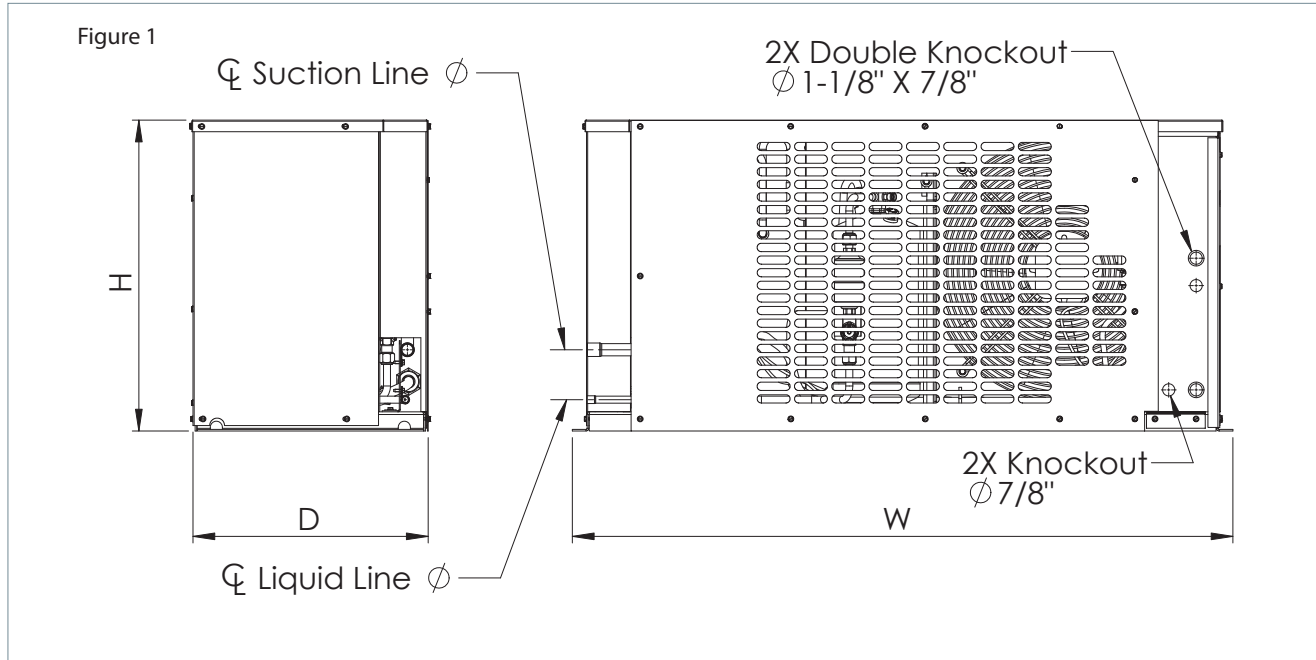

Electrical Code N: HJZM0150, HNXM0200-0400, HRXM0500, LJHM0150-0200

Wiring Diagram 119-8312

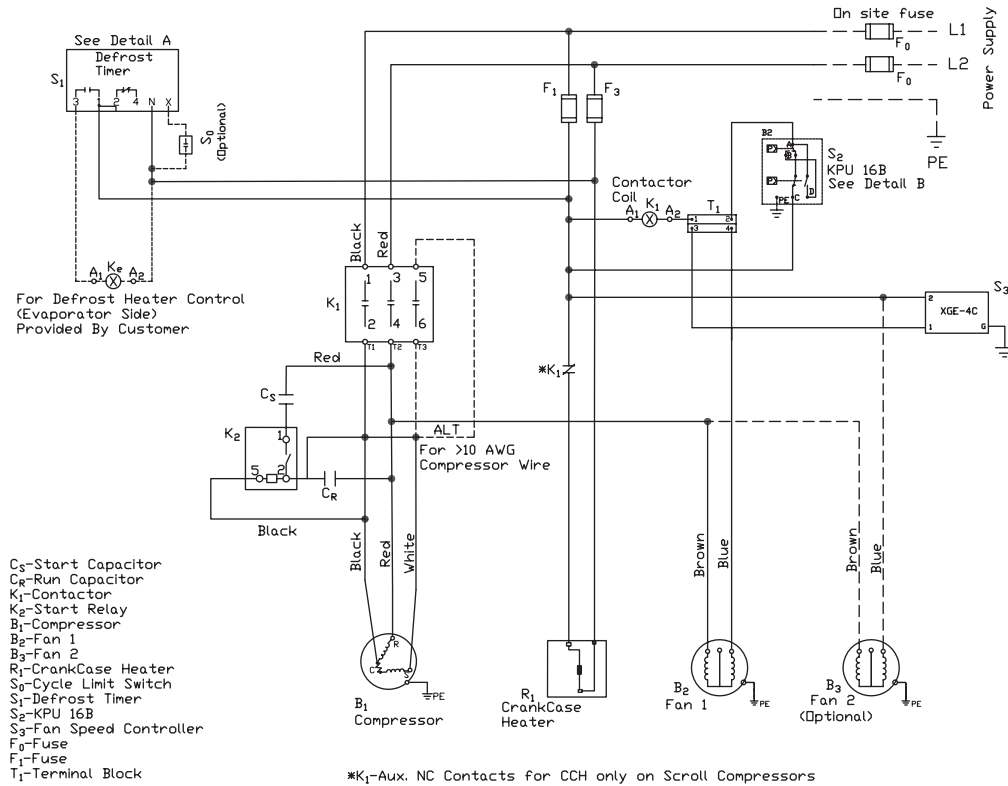

119-8312
230V 1Ph 60Hz

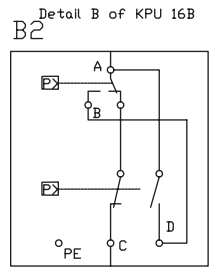
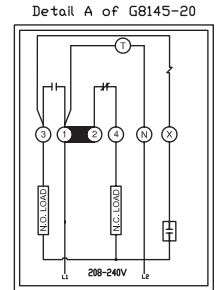

Electrical Code Q: HNXM0200-0400, HRXM0500-1000

Wiring Diagram 119-8313

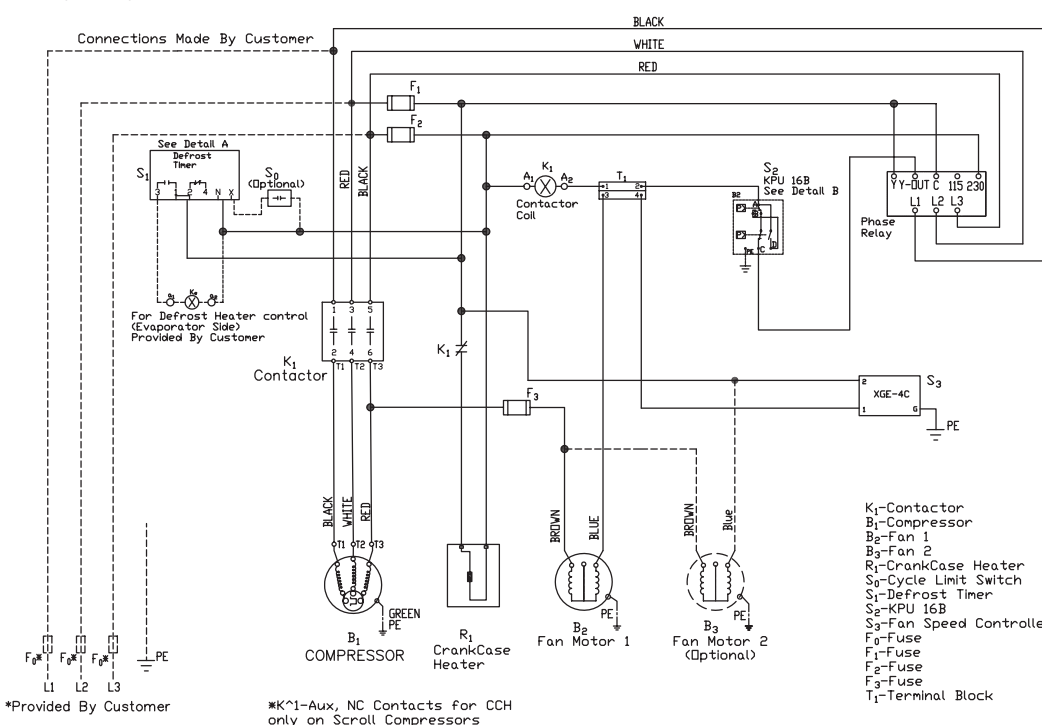

119-8313
230V 3PH 60Hz

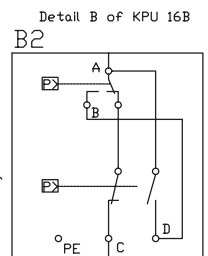
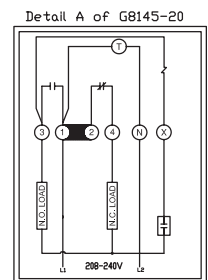

- K₁-Contactor
- B₁-Compressor
- B₂-Fan 1
- B₃-Fan 2
- R₁-CrankCase Heater
- S₀-Cycle Limit Switch
- S₁-Defrost Timer
- S₂-KFU 16B
- S₃-Fan Speed Controller
- F₀-Fuse
- F₁-Fuse
- F₂-Fuse
- F₃-Fuse
- T₁-Terminal Block

Electrical Code Q: HJZM0150, LJHM0150-0200

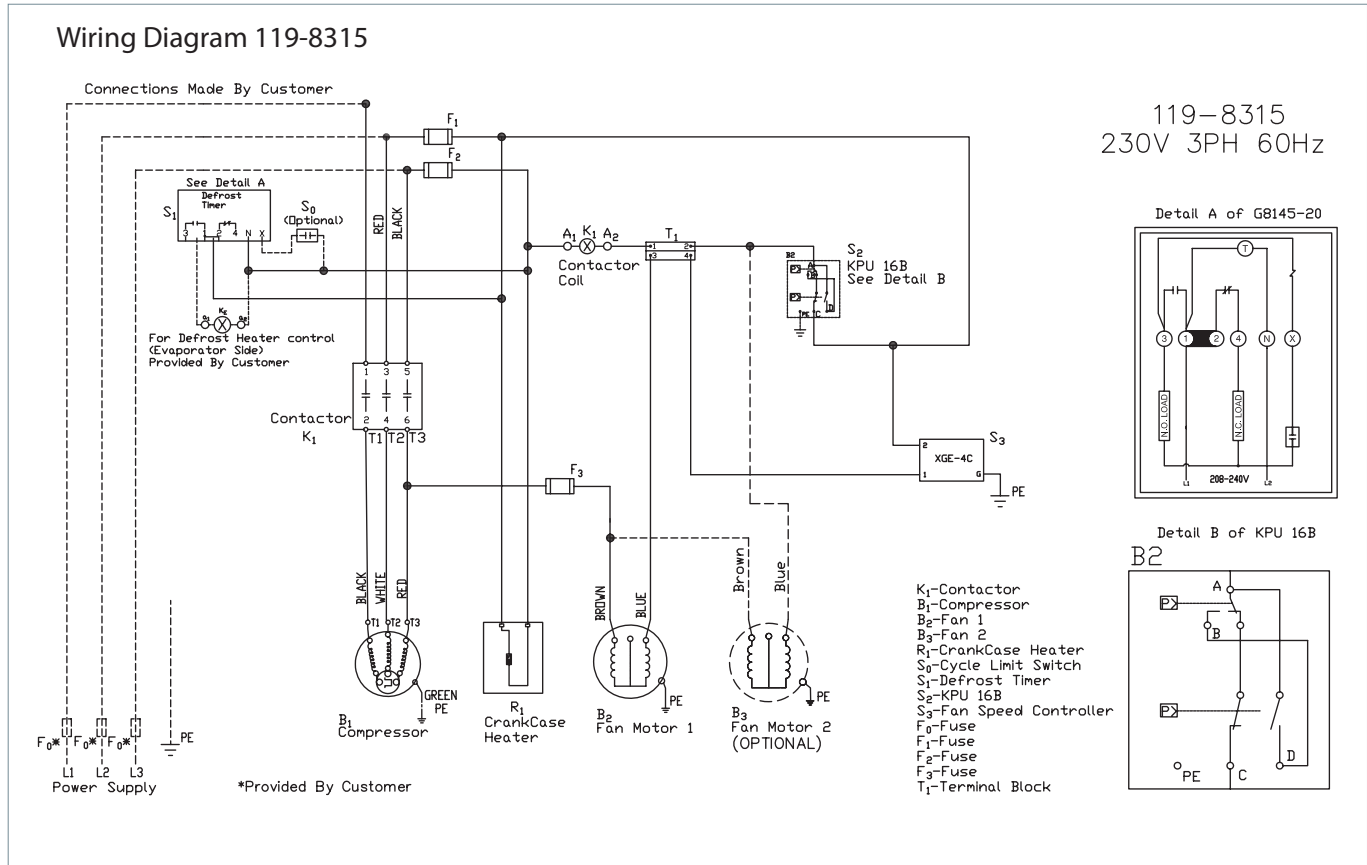

Electrical Code Q: LNYM0400-0500-0600, LRYM0800

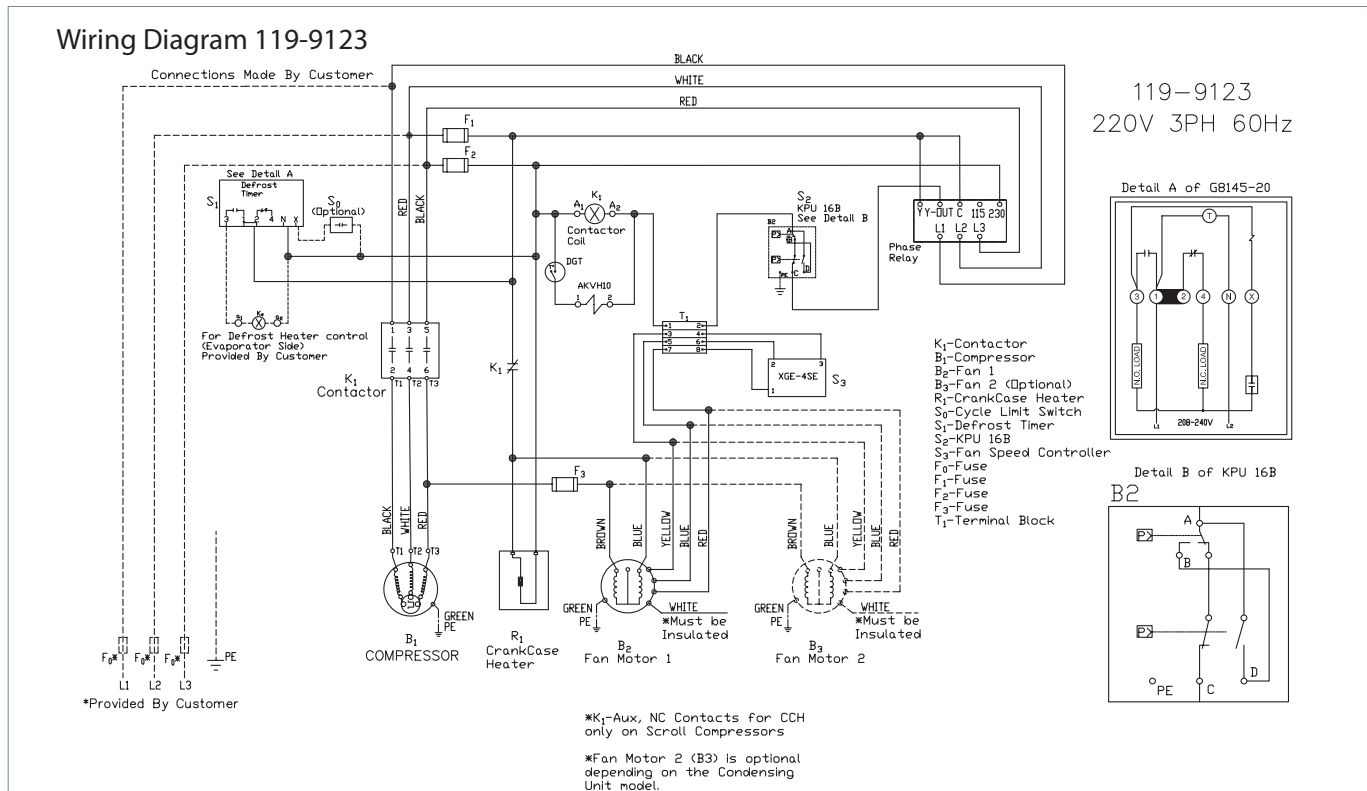

Electrical Code R: HRZM0600-1000

Wiring Diagram 119-8640

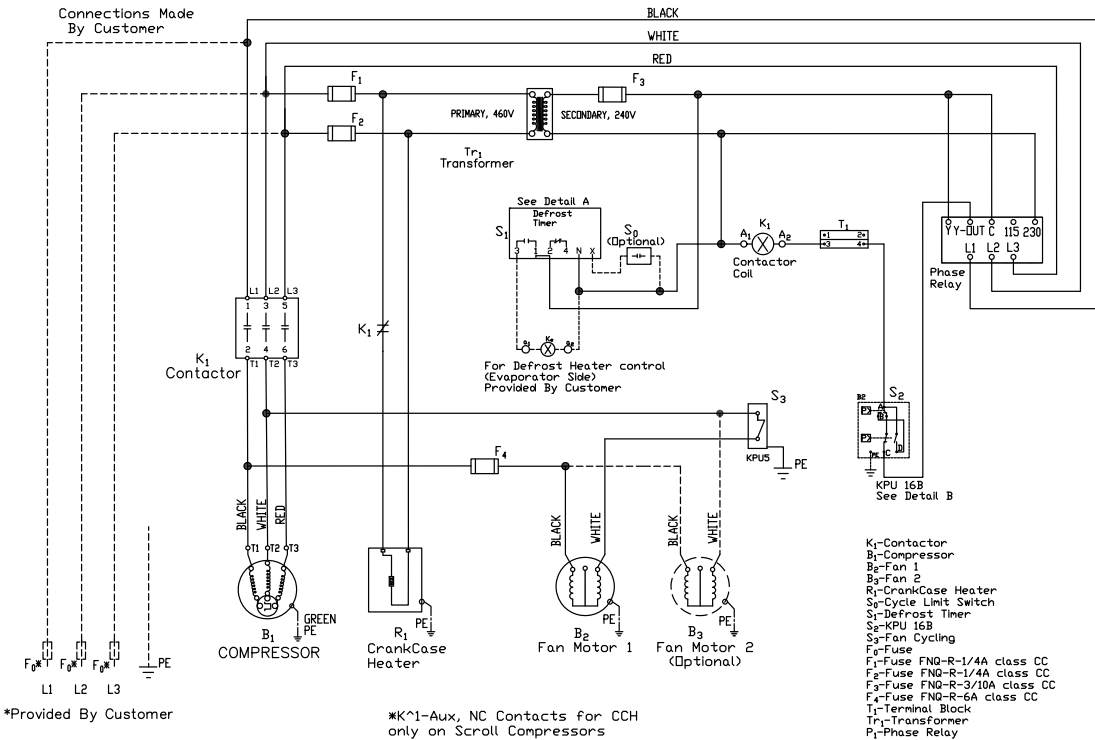

119-8640
460V 3PH 60Hz

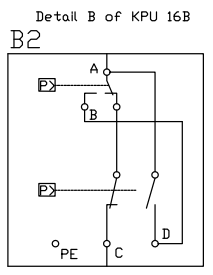
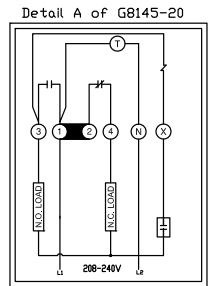

- K₁-Contactor
- B₁-Compressor
- B₂-Fan 1
- B₃-Fan 2
- R₁-CrankCase Heater
- S₀-Cycle Limit Switch
- S₁-Defrost Timer
- S₂-KPU 16B
- S₃-Fan Cycling
- F₁-Fuse
- F₂-Fuse FNO-R-1/4A class CC
- F₃-Fuse FNO-R-1/4A class CC
- F₄-Fuse FNO-R-3/10A class CC
- F₄-Fuse FNO-R-6A class CC
- T₁-Terminal Block
- Tr₁-Transformer
- P₁-Phase Relay

Electrical Code R: LRYM0600-0800

Wiring Diagram 119-8641

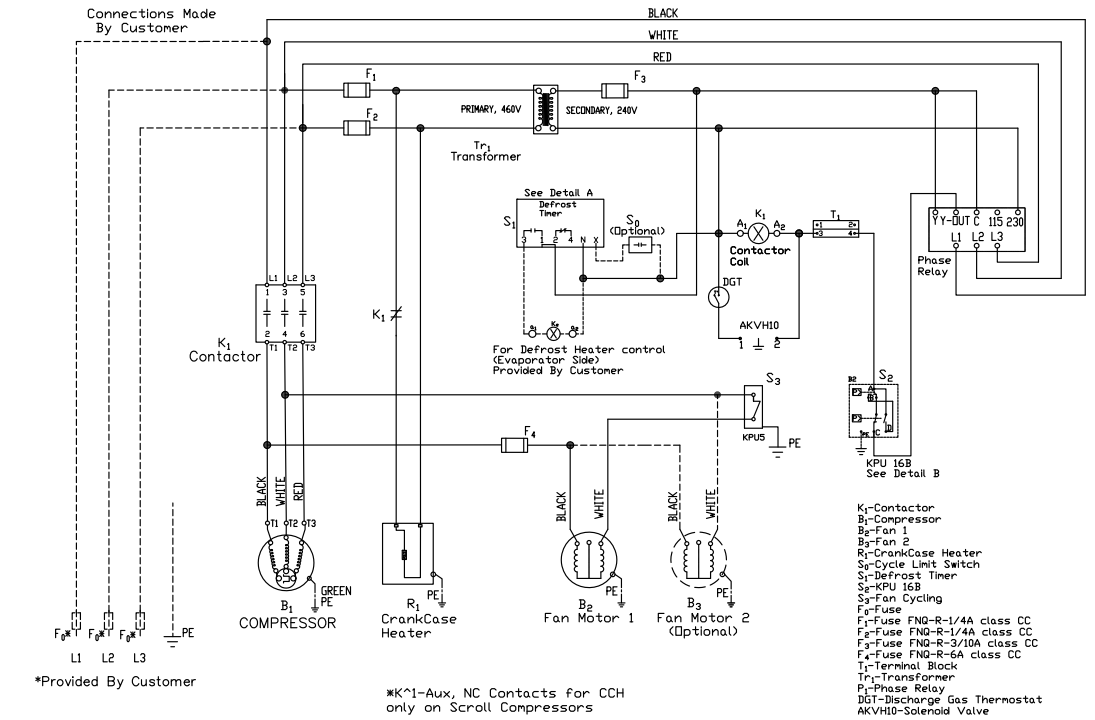

119-8641
460V 3PH 60Hz

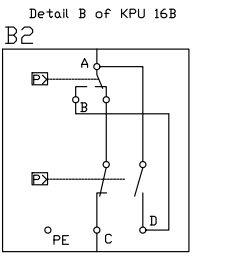
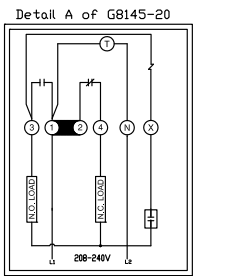

- K₁-Contactor
- B₁-Compressor
- B₂-Fan 1
- B₃-Fan 2
- R₁-CrankCase Heater
- S₀-Cycle Limit Switch
- S₁-Defrost Timer
- S₂-KPU 16B
- S₃-Fan Cycling
- F₁-Fuse
- F₂-Fuse FNO-R-1/4A class CC
- F₃-Fuse FNO-R-1/4A class CC
- F₄-Fuse FNO-R-3/10A class CC
- F₄-Fuse FNO-R-6A class CC
- T₁-Terminal Block
- Tr₁-Transformer
- P₁-Phase Relay
- DGT-Discharge Gas Thermostat
- AKVH10-Solenoid Valve

Electrical Code N: HNXM0200-0400, HRXM0500

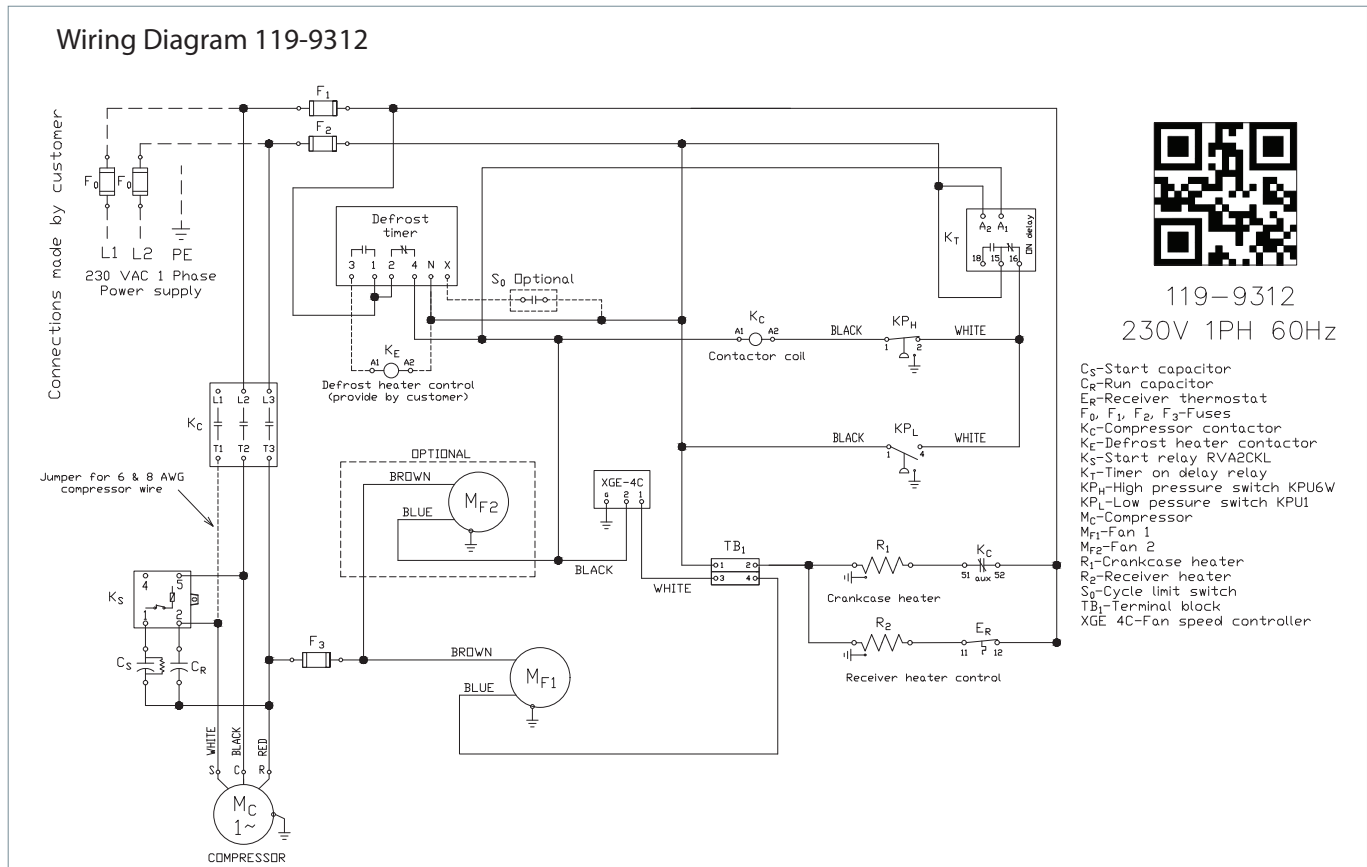

Electrical Code N: HJZM0150

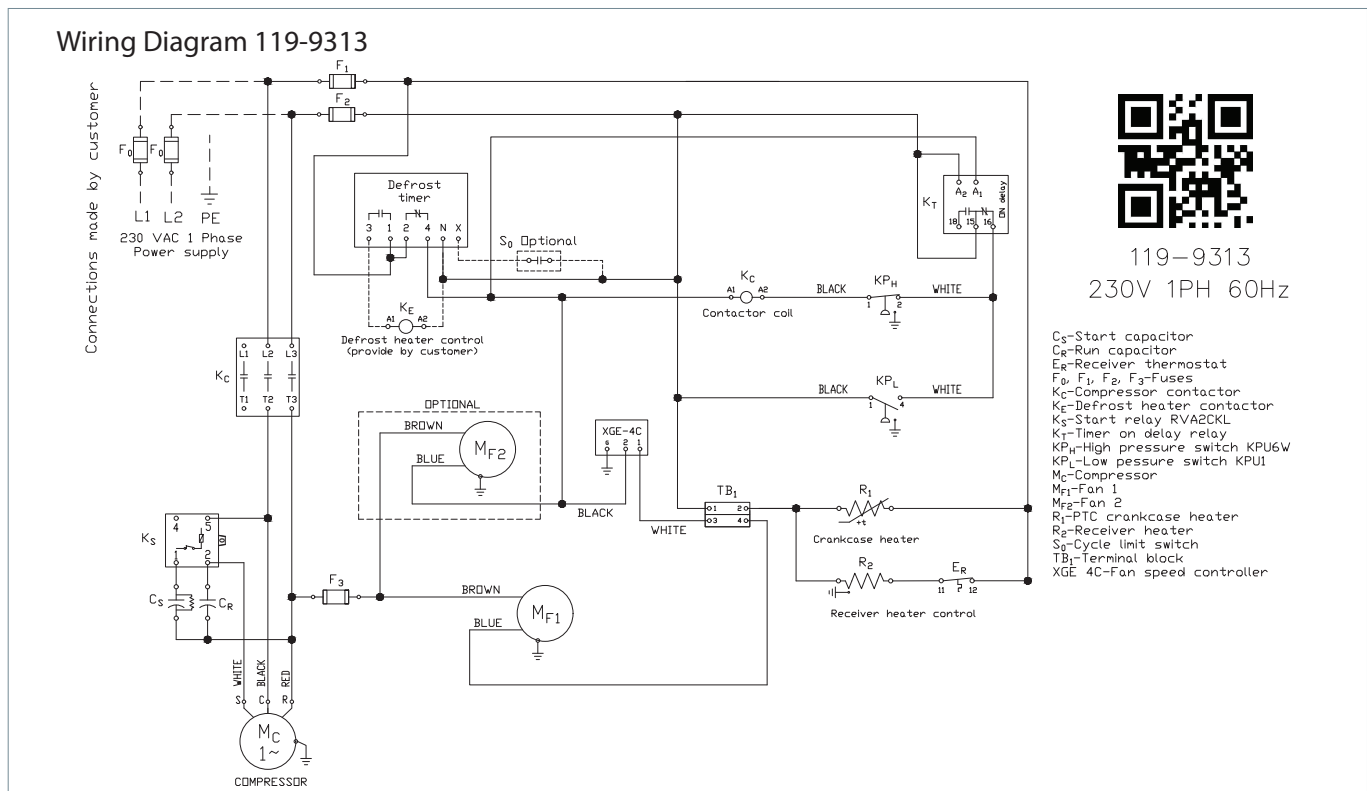

Electrical Code Q: LNYM0400-0500-0600 LRYM0800

Wiring Diagram 119-9314

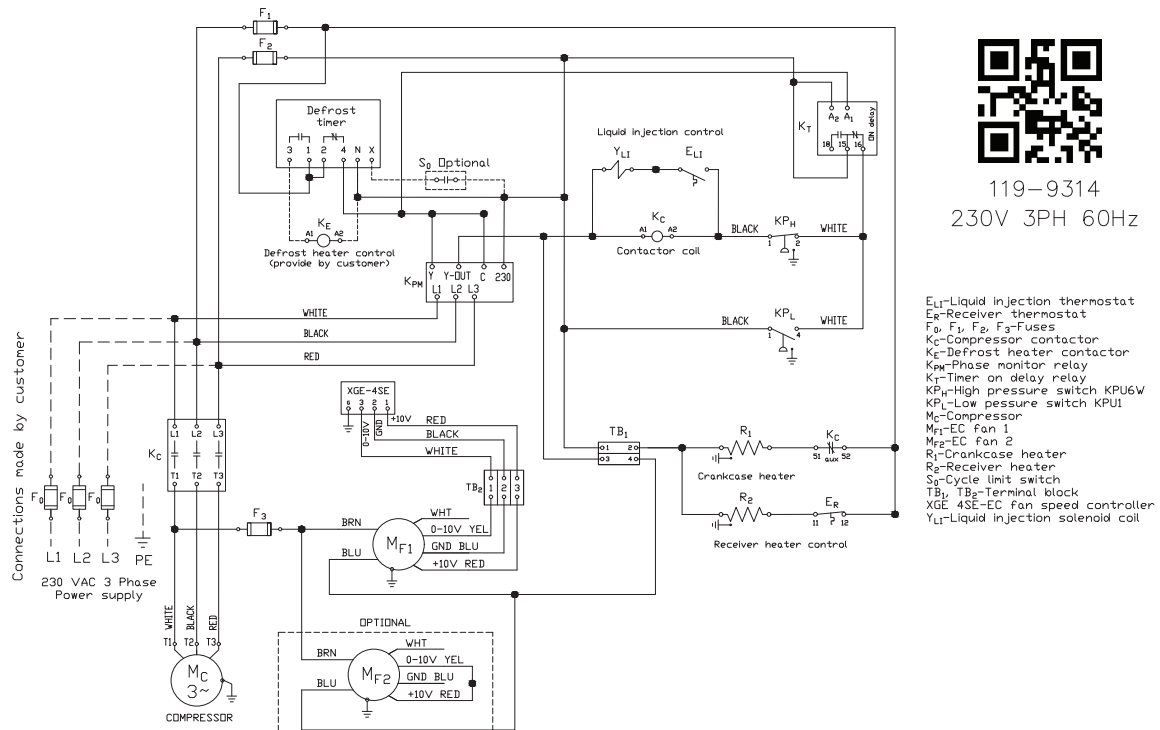

Electrical Code Q: HNXM0200-0400, HRXM0500-1000

Wiring Diagram 119-9326

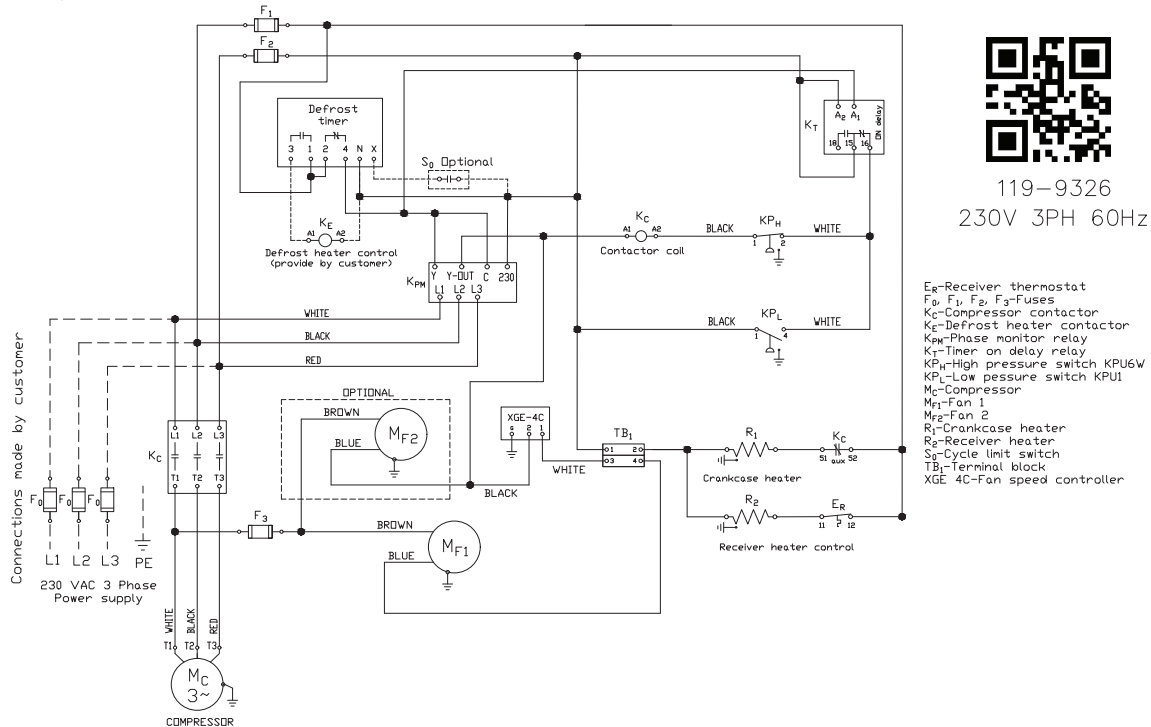

Electrical Code Q: HJZM0150

Wiring Diagram 119-9327

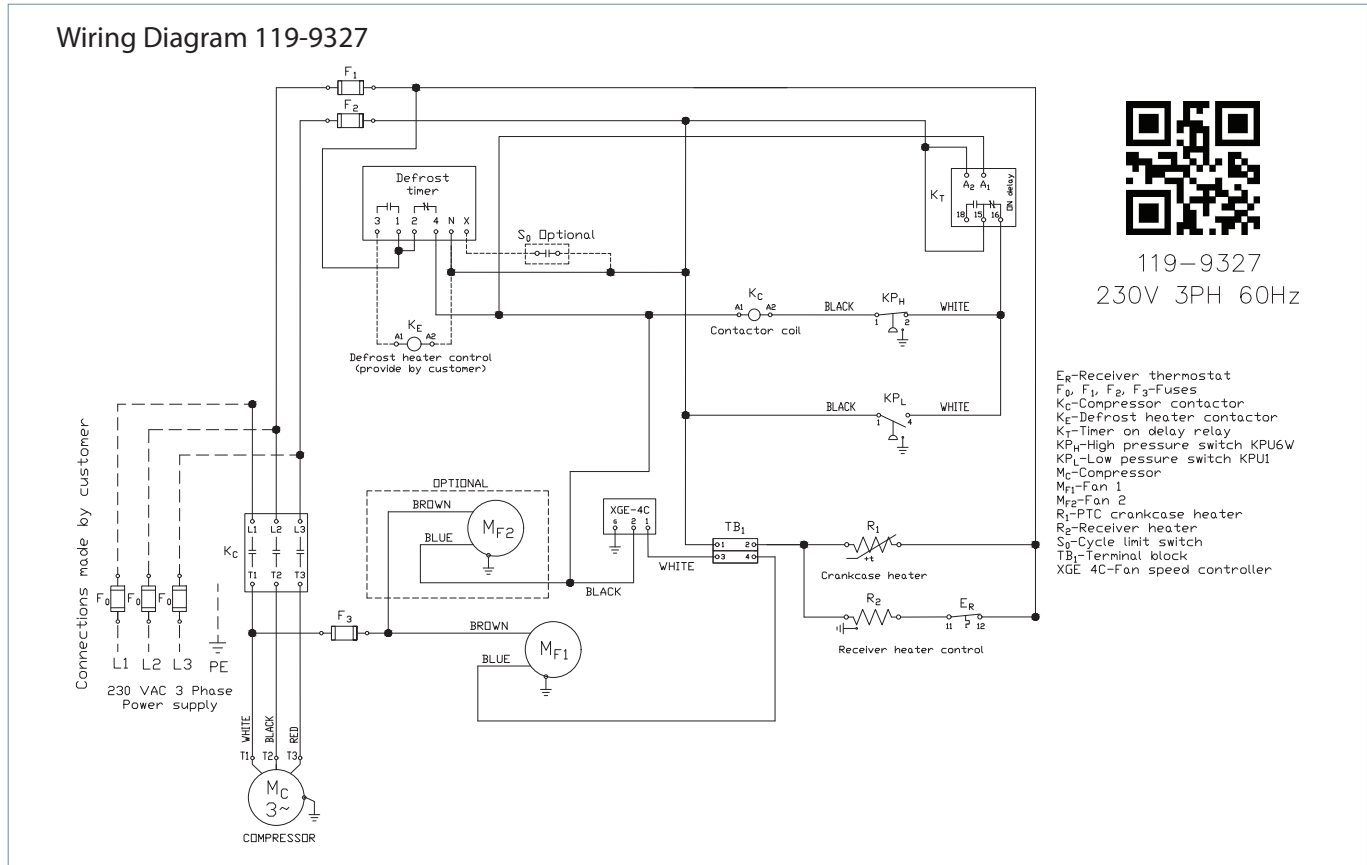

119-9327
 230V 3PH 60Hz

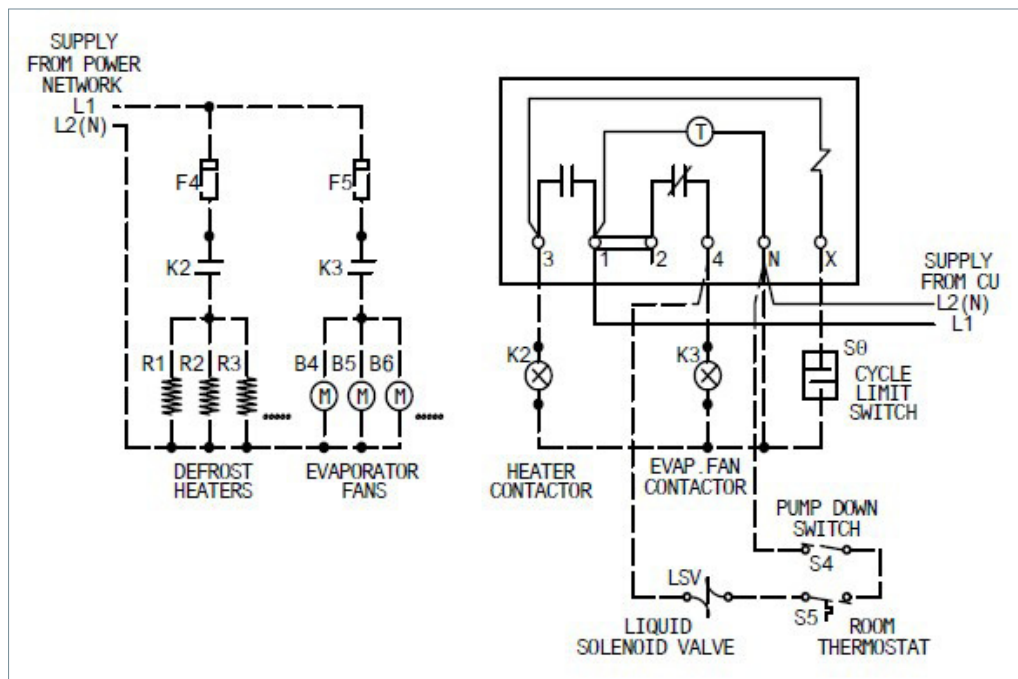

**Sequence of operation
Refrigeration Cycle**

1. Defrost timer is powered by the condensing unit, connecting the supply to terminal "1" and "N".
2. The fan delay and the defrost termination thermostat is closed in the fan delay position and open in the defrost termination position. The evaporator fan(s) run continuously.
3. The defrost heaters are off during refrigeration cycle.
4. The room thermostat closes when the temperature rises above the desired setting.
5. The liquid line solenoid valve (LSV) gets energized and opens to allow the liquid refrigerant to flow through the evaporator.
6. The low-pressure control switch closes when the suction pressure rises above the cut-in setting.
7. The compressor contactor gets energized and supply power to allow the compressor and condenser fan to run.
8. The room temperature gradually decreases to the desired temperature.
9. Once the desired temperature is attained, the thermostat opens and the liquid line solenoid closes, it will in turn stop the refrigerant flow through the evaporator.
10. Suction pressure decreases and the compressor contactor opens when the pressure drops below the cut-out setting on the low-pressure control. The compressor and condenser fan stop running.
11. This cycle is repeated as many times as necessary to satisfy the room thermostat.
12. Frost may form on the evaporator coil until the defrost cycle is initiated.

Defrost Cycle

1. The defrost cycle starts automatically by the timer at predefined intervals. Typical settings are between two and four defrost cycles per day for freezers. For heavier frost loads additional settings may be required.
2. Contacts "2" to "4" opens in the defrost timer and disconnects the circuit to the room thermostat, liquid line solenoid, and evaporator fan motors. This will lead the compressor to pump down and shut-off. At the same time, Contacts "1" to "3" closes in the timer and it will allow the defrost heater to start through the heater contactor.
3. The defrost heaters rise the temperature of the coil to 32°F triggering the frost to melt of the coil.
4. When the coil temperature rises to 45°F to 55°F, the cycle limit switch closes and it energizes the Liquid line solenoid valve to allow the refrigeration cycle to begin again.

5. If the termination thermostat fails to close, the fail-safe set on the timer will terminate the defrost.
6. The defrost heaters are off.
7. The low-pressure control closes when the cut-in pressure is attained, allows the compressor to start.
8. When the evaporator coil temperature reaches 23°F to 30°F, the fan delay closes and allows the fan motors to run.
9. The system will now operate in the refrigeration cycle until another defrost cycle is triggered by the timer.

NOTE

This wiring diagram is for field reference only.

1) Two contactors one for evaporator fan and other for defrost heater will be needed. No extra contactors to be provided with the unit.

2) Fuse F4 for defrost heaters and cable and Fuse F5 for evaporator fans and cables will not be supplied with the unit. These will need to be purchased separately.

Hailguard Installation

1. Identify the hailguard size needed and trim the hailguard (if needed) based on the table shown below, cutting with scissors or utility knife

Model	Dimensions			
	Length		Height	
	in.	mm	in.	mm
HJXM0150-0200 LJHM0150-0300	26	660	19	480
HJXM0200-0300	29	740	22	550
LN YM0400-0600 HJXM0350-0400	31	780	27	700
HRXM0500-0700 LRYM0800	46	1170	28	720
HRXM0750-1000	58	1470	38	970

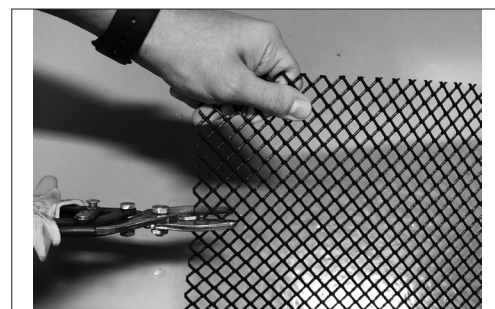

2. Remove the screws from the sides and top of the condenser.



3. Lock the hailguard into place by reattaching the screws. Start on the left side, unrolling the hailguard before attaching to the right side. Pull tight as you progress.



4. The hailguard is now attached and will protect your Optyma Slim condensing unit from hail and other elements.

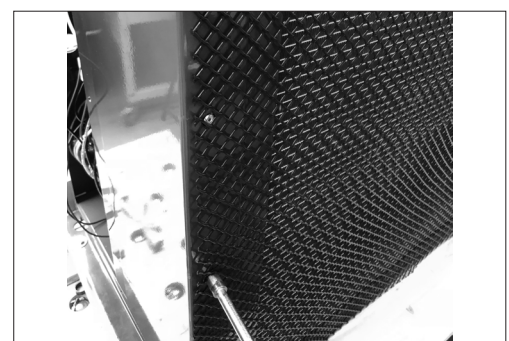

Danfoss Commercial Compressors

is a worldwide manufacturer of compressors and condensing units for refrigeration and HVAC applications. With a wide range of high quality and innovative products we help your company to find the best possible energy efficient solution that respects the environment and reduces total life cycle costs.

We have 40 years of experience within the development of hermetic compressors which has brought us amongst the global leaders in our business, and positioned us as distinct variable speed technology specialists. Today we operate from engineering and manufacturing facilities spanning across three continents.



Danfoss Inverter Scrolls



Danfoss Turbocor Compressors



Danfoss Scrolls



Danfoss Optyma Condensing Units

Danfoss Light Commercial Refrigeration Compressors



Danfoss Maneurop Reciprocating Compressors

Disclosure: This equipment is prohibited from use in California with any refrigerants on the "List of Prohibited Substances" for that specific end-use, in accordance with California Code of Regulations, title 17, section 95374. This disclosure statement has been reviewed and approved by Danfoss LLC and Danfoss LLC attests, under penalty of perjury, that these statements are true and accurate".

Our products can be found in a variety of applications such as rooftops, chillers, residential air conditioners, heatpumps, coldrooms, supermarkets, milk tank cooling and industrial cooling processes.

Danfoss A/S
Climate Solutions • danfoss.us • +1 888 326 3677 • heating.cs.na@danfoss.com



119-8385G

Any information, including, but not limited to information on selection of product, its application or use, product design, weight, dimensions, capacity or any other technical data in product manuals, catalogues descriptions, advertisements, etc. and whether made available in writing, orally, electronically, online or via download, shall be considered informative, and is only binding if and to the extent, explicit reference is made in a quotation or order confirmation. Danfoss cannot accept any responsibility for possible errors in catalogues, brochures, videos and other material. Danfoss reserves the right to alter its products without notice. This also applies to products ordered but not delivered provided that such alterations can be made without changes to form, fit or function of the product. All trademarks in this material are property of Danfoss A/S or Danfoss group companies. Danfoss and the Danfoss logo are trademarks of Danfoss A/S. All rights reserved.