

Installation guide/Electronic part replacement (Not applicable for SIL2 devices)

Liquid Level Switch

Type LLS 4000 / LLS 4000U



148R9652



Warning! This is a Class A device. This device may cause radio interference in residential areas. In case of interference, the operator may be required to take appropriate measures. This instrument has to be mounted on a metallic tank. The device is intended to be used in industrial areas.

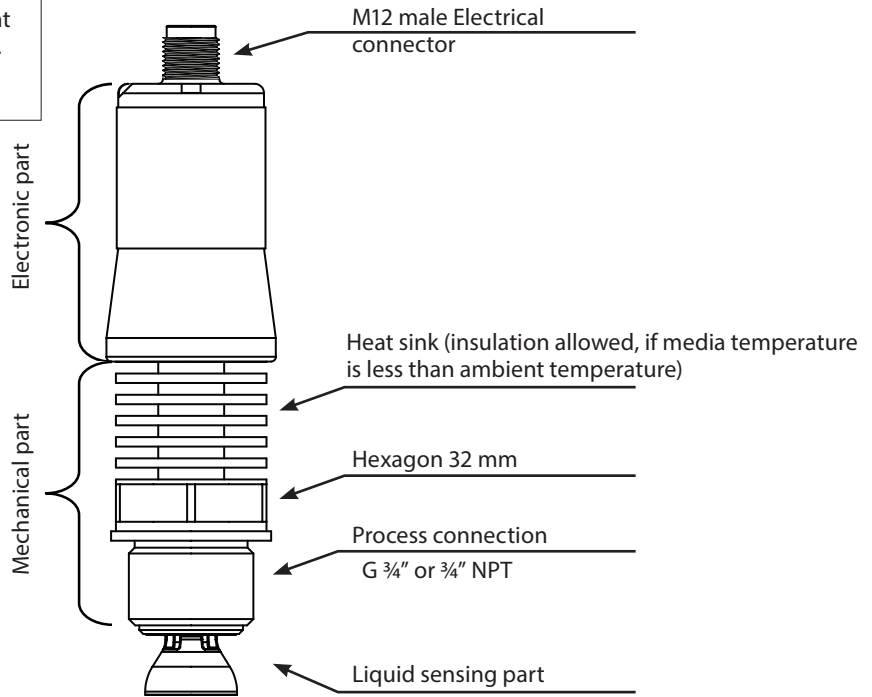

148R9652

Fig. 1

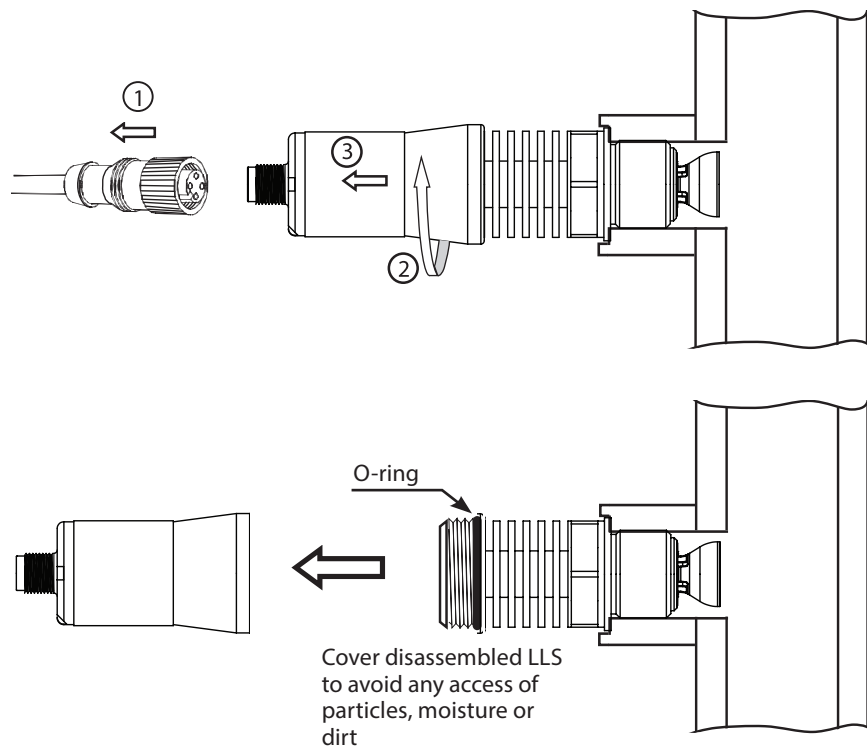

Fig. 2

Info for UK customers only : Danfoss Ltd., 22 Wycombe End, HP9 1NB, GB

Імпортер: ТОВ з іі "Данфосс ТОВ" 04080, Київ 80, п/с 168, Україна

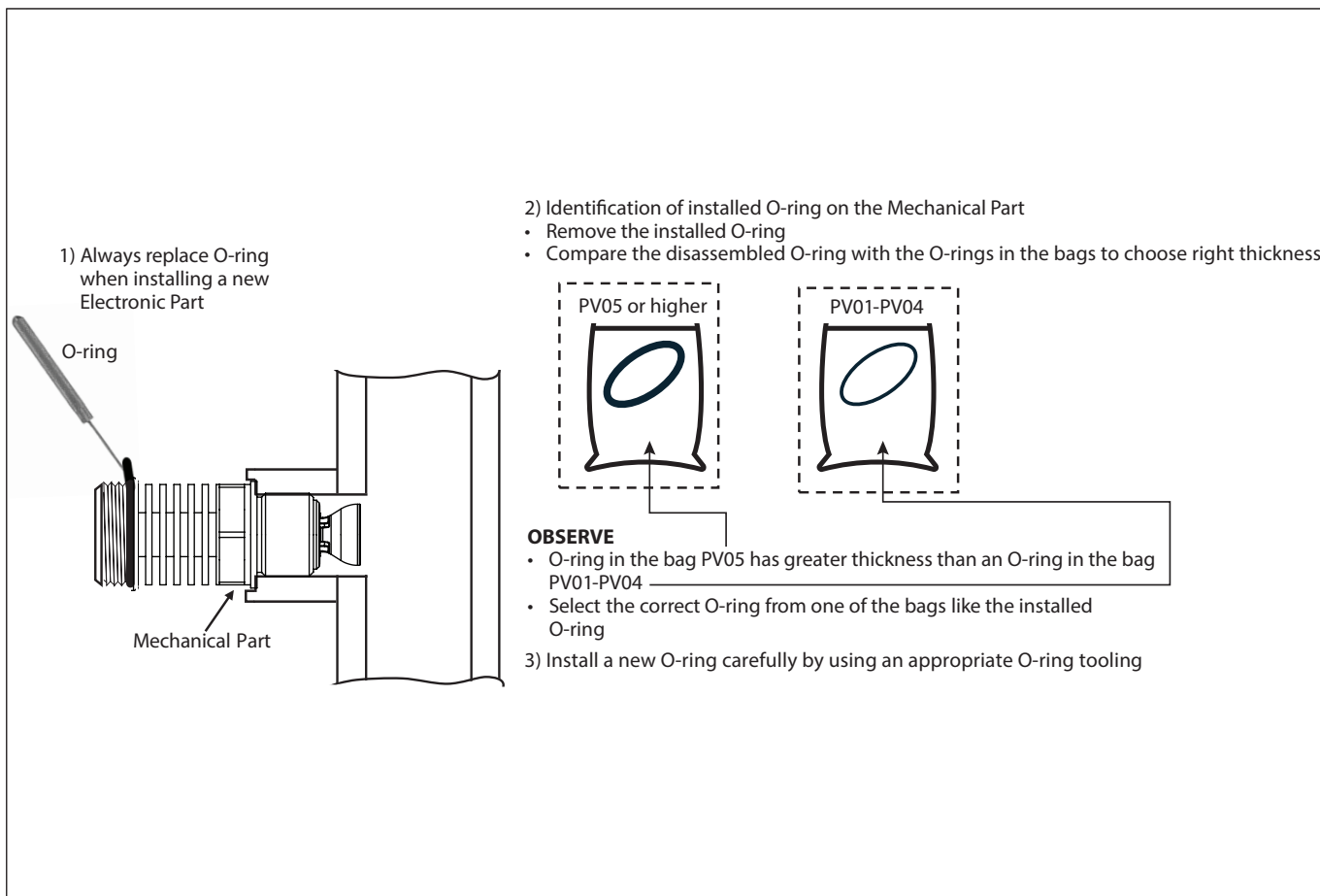

Fig. 3

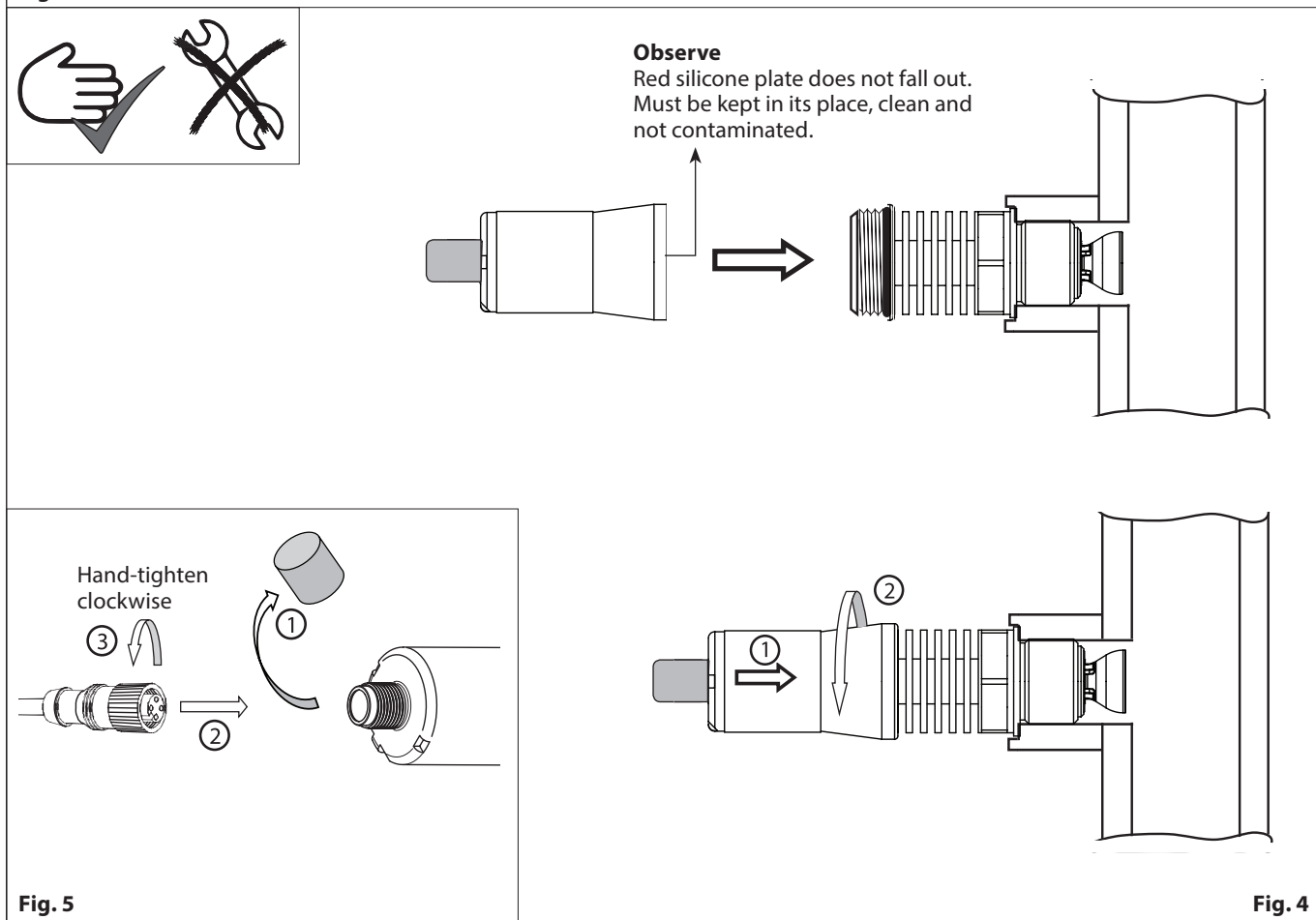

Fig. 5

Fig. 4

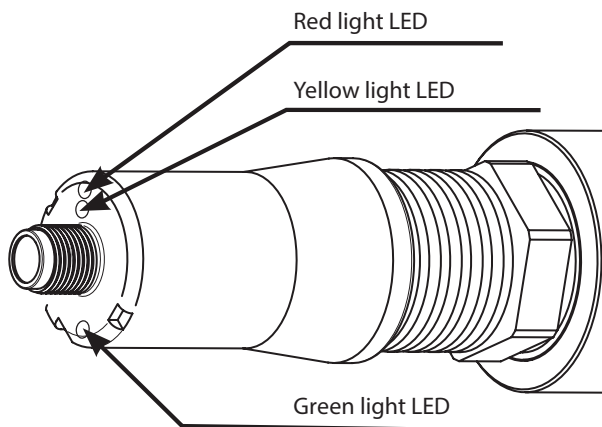

Fig. 6

	Level	LLS 4000/4000U NO mode*	LLS 4000/4000U NC mode*	Voltage connected	Level detection	LLS 4000/4000U Fault
				Green LED	Yellow LED	Red LED
High Level sensor				●		
High Level sensor				●	●	
Low Level sensor				●	●	
Low Level sensor				●		
Voltage supply outside spec.	-					
LLS 4000/4000U fault**	-			●	●***	●

SIL2 fixed configuration

	Green LED ON		Yellow LED ON		Red LED ON		Green LED Flashing. LLS 4000/4000U connected to Bluetooth device
--	--------------	--	---------------	--	------------	--	---

* Configuration dependent. Non-SIL2 fully configurable. SIL2 fixed configuration and only applicable for High Level sensor
 ** For failure types please connect the device to the Bluetooth App, enter fault state mode, and read the failure type
 *** Fault can be detected at any detected level, ie. 2 or all 3 lights on

LLS Bluetooth app download

1

2 **Search** LLS 4000

3 download

4

Observe!
 Always download or update to latest App version.
 Devices with Firmware PV01 (see product label) must be Firmware updated to latest firmware before configuration. Please contact Danfoss.

Configuration

1

2

3

4

5

6

Pin code: 0000

Configuration continued

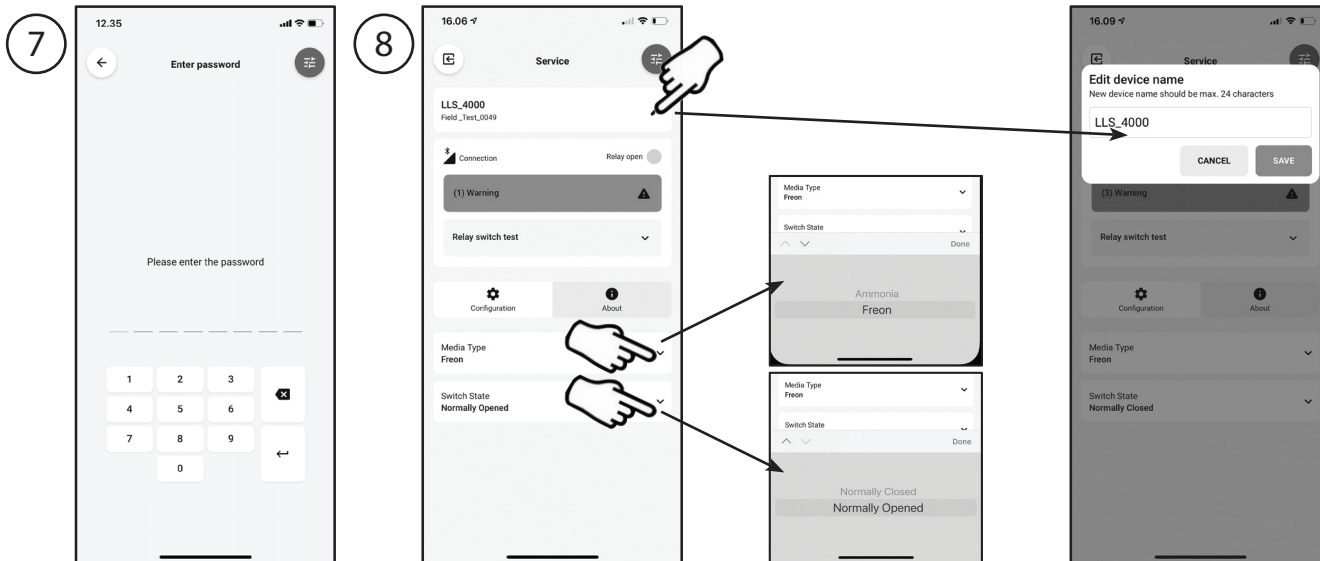

Password: 12131400*

* In Service menu a unique password for Service menu can be entered.
 Go to menu upper right -> Go login -> Go to settings ->
 Go to Service Password -> Enter new Service Password

Calibration

For all media except Ammonia - R717:

- Mandatory that calibration is done, and always in gas.

For Ammonia - R717:

- It is highly recommended that calibration is done in gas.
- Exception when LLS 4000/4000U is used for low level detection:
 If it is absolutely not possible to empty the stand pipe for liquid ammonia, it is acceptable to skip the calibration of the LLS 4000/4000U in gas.

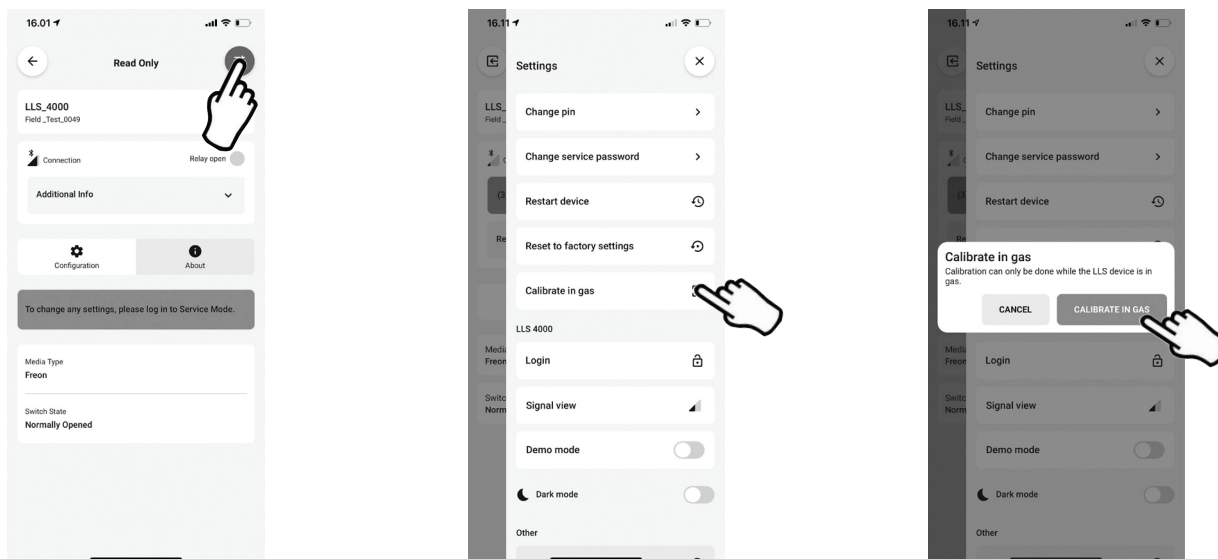

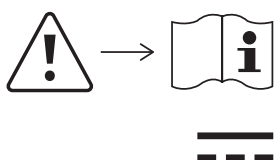
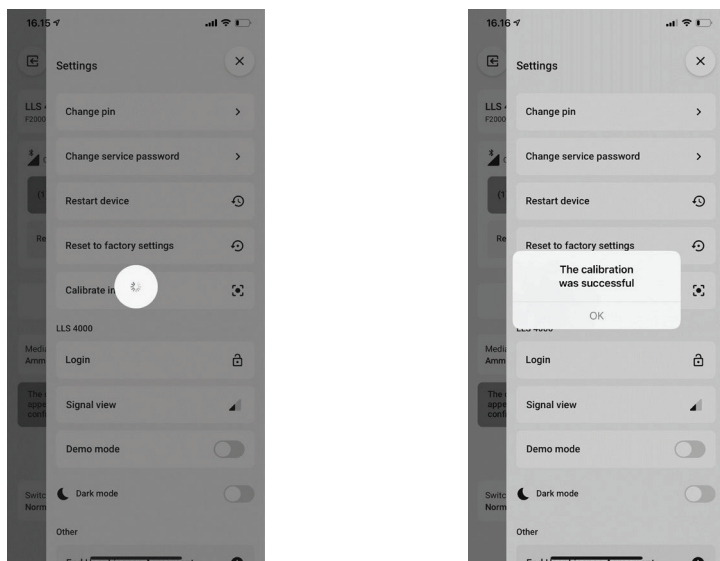

Read and apply safety instructions contained in product documentation.

Direct current.

General warnings/precautions

- Instructions in this document should only be used for electronic part replacement. For device installation refer to Installation guide/Quickstart document.
- LLS 4000/U electronic part replacement is not allowed on SIL device version.
- LLS 4000/U electronic part should only be used as spare part of LLS4000/U liquid level switch.
- Every use that is not described in this guide is considered incorrect and is not authorized by the manufacturer.
- If any changes regarding installation, media or operating conditions of the device have been done then refer to Installation guide/Quickstart document and verify respect of specified values.
- All service and maintenance operations must be performed by qualified personnel.
- Installation must comply with local standards and legislation.
- Before carrying out any maintenance operations on the device, disconnect the device from the main power supply.
- Before unscrewing the LLS device from the pipe or tank ensure that pipe or tank is empty and not under pressure.
- Liability for injury or damage caused by incorrect use of the device lies solely with the user.
- Depending on the application, the metallic part of the instrument may be hot or cold.
- If media detection or non-detection by the level switch could generate a hazard the SIL version and specific instructions described in the safety manual (periodic proof test) should be used. The SIL safety manual can be downloaded from Danfoss web site or by scanning the QR code below.

For further documents (Installation guide, Data sheet, etc.) scan this QR code:



Danfoss A/S, 6430 Nordborg, Denmark
www.danfoss.com



Danfoss A/S

Climate Solutions • danfoss.com • +45 7488 2222

Any information, including, but not limited to information on selection of product, its application or use, product design, weight, dimensions, capacity or any other technical data in product manuals, catalogues descriptions, advertisements, etc. and whether made available in writing, orally, electronically, online or via download, shall be considered informative, and is only binding if and to the extent, explicit reference is made in a quotation or order confirmation. Danfoss cannot accept any responsibility for possible errors in catalogues, brochures, videos and other material. Danfoss reserves the right to alter its products without notice. This also applies to products ordered but not delivered provided that such alterations can be made without changes to form, fit or function of the product.

All trademarks in this material are property of Danfoss A/S or Danfoss group companies. Danfoss and the Danfoss logo are trademarks of Danfoss A/S. All rights reserved.