

ENGINEERING
TOMORROW

Danfoss

Operator's Manual

ET6110 Skiving Machine



Imprint

Manufacturer:

UNIFLEX-Hydraulik GmbH
Robert-Bosch-Strasse 50-52
D-61184 Karben
Germany

Phone: +49 (0) 60 39 / 91 71 - 0

Fax: +49 (0) 60 39 / 91 71 - 181

This Operating Manual of the machine is a translation; the original is in German.

Date of revision: 2024-07-22

Version: 1.1

© Copyright by UNIFLEX-Hydraulik GmbH

Technical modifications reserved.

The reproduction, distribution and utilization of this document as well as the communication of its contents to others without explicit authorization are prohibited. Offenders will be held liable for the payment of damages. All rights reserved in the event of the grant of a patent, utility model or design.

EC / UK - Declaration of Conformity

In accordance with EC Machinery Directive 2006/42/EC and UK-Supply of Machinery (Safety) Regulations 2008.

The following machine

ET6110

was developed, designed and manufactured in compliance with EC Directive 2006/42/EC and UK-Supply of Machinery (Safety) Regulations 2008, in the sole responsibility of

UNIFLEX-Hydraulik GmbH
Robert-Bosch-Strasse 50 - 52
D-61184 Karben

The following standards, codes and specifications have been applied:

- EC Directive 2006/42/EC
- EMC Directive 2014/30/EC
- EN ISO 12100: 2010
- EN 60204-1: 2018
- UK-Supply of Machinery (Safety) Regulations 2008
- UK-Electromagnetic Compatibility Regulations 2016

This declaration are invalid when the machine is modified or if unauthorized and unapproved third-party components are used without our prior approval.

Entity authorised for documentation: Uniflex-Hydraulik GmbH, Technical Documentation Dept.

Karben, 11.10.2022



Managing Director Harald von Waitz

Contents

1	About this document	6
1.1	Target groups	6
1.2	Storage	8
1.3	Name plate	8
2	Safety instructions	9
2.1	Presentation of warnings	9
2.2	Intended use	9
2.3	Product-specific risks	10
2.3.1	Risks imposed by mechanical equipment	10
2.3.2	Risks imposed by electricity	11
2.3.3	Risks imposed by noise	11
2.3.4	Risks imposed by substances	12
2.3.5	Risks in case of fire	12
2.4	Safety	13
2.4.1	Working area	13
2.4.2	Emergency-stop	14
2.4.3	Protection equipment	14
2.4.4	Warning signs on the machine	15
3	Machine description	16
3.1	Design and function	16
3.2	Operation and display elements	17
3.3	Technical data	18
4	Transport and commissioning	20
4.1	Transport	20
4.2	Intermediate storage of machine/unit	20
4.3	Commissioning	22
4.3.1	Inserting the internal skiving mandrel	23
4.3.2	Setting the internal skiving diameter	24
4.3.3	Inserting the external skiving tool	24
4.3.4	Adjusting the external skiving diameter	25
4.3.5	Adjusting the external skiving depth	25
4.3.6	Electrical connection	26
5	Operation	27

Contents

5.1	What you have to observe	27
5.2	Start	27
5.3	Skiving the workpiece	28
5.3.1	Prerequisites.....	28
5.3.2	Skiving the workpiece	28
5.4	Stop	30
5.5	Emergency-stop.....	31
5.6	Cleaning.....	31
6	Maintenance.....	32
6.1	What you have to observe	32
6.2	Maintenance schedule.....	32
6.3	Replacing the skiving knives	34
6.3.1	Removing the external skiving tool	34
6.3.2	Replacing the external skiving knife.....	35
6.3.3	Replacing the internal skiving knife.....	36
6.4	Changing break pads.....	37
7	Troubleshooting	38
8	Decommissioning, disposal	39
8.1	Dismantling	40
8.2	Recycling	40
8.3	Consumables and waste.....	40
9	Annex	41
9.1	Accessories (retrofitable)	41
9.2	Spare parts list.....	43
9.3	Spare parts set	47
9.4	Electric diagram	48
9.5	Maintenance log.....	49
9.6	Declaration of qualified staff.....	50

1 About this document

1.1 Target groups

1 About this document

In this Operation Manual, the “hose skiving machine ET6110“ is consistently referred to as machine.

This Operation Manual includes important notes on how you operate your machine/unit safely, properly and economically.

Use not in compliance with the intended purpose may result in hazard to the operator's health and life and/or in the risk of damage to/the machine/unit. Consequently, please only use the machine/unit

- in good order and condition,
- in accordance with its intended purpose,
- in a safety-conscious manner, with awareness of risks and hazards,
- in compliance with all notes included in this Operation Manual.

The machine/unit may only be operated by staff who

- has read the Operation Manual,
- has understood it,
- has been instructed in the operation of the machine/unit, and
- has signed in the Annex.



Figures may include accessories/options. Customer-specific equipment may vary.

The product images shown are for reference only and may differ from the product delivered.

1.1 Target groups

The target groups of this Operation Manual are:

Owner

An owner is a natural person or entity using the device himself/herself/itself, or on whose behalf the device is used. An owner may appoint a representative to exercise the owner's rights and obligations.

The owner has to make sure that

1 About this document

1.1 Target groups

- national provisions, occupational safety regulations and applicable environmental protection regulations are fully complied with;
- persons working on the machine/unit are adequately qualified;
- persons working on the machine/unit are suitable for operating the machine/unit;
- the Operation Manual has been read and understood. One hardcopy of the Operation Manual must always be kept at a designated place where the machine/unit is used.
- persons working on the machine/unit are aware of potential risks;
- the operating staff is familiar with the location as well as with operating the fire alarm and fighting means. Free access to this equipment must be ensured.
- personal protection equipment is worn (safety footwear, protection gloves and safety glasses).

Machine/unit fitters

Machine/unit fitters must be at least 18 years old and have completed training for the task, i.e. they must have attended a specialist vocational training.

A fitter

- must observe the instructions in the Operation Manual;
- must inform the owner on failures and damage.

Operator

An operator is a person charged with and instructed in the proper operation of the machine/unit by the owner or the otherwise contractually obliged person.

The operator

- must observe the instructions in the Operation Manual;
- must inform the owner on failures and damage.
- must not perform and maintenance or repair work on the machine/unit.

1 About this document

1.2 Storage

1.2 Storage

The Operation Manual is part of the machine/unit and must be kept near the machine/unit at all times. Upon disposal of the machine/unit, the Operation Manual must also be handed over.

1.3 Name plate

The name plate is fixed near the power cable.

2 Safety instructions

2.1 Presentation of warnings

2 Safety instructions

2.1 Presentation of warnings

Warning notes in the Operation Manual warn against risks involved with the handling of the machine/unit. Risk levels are identified as follows:

**HAZARD!**

The signal word HAZARD identifies an imminent hazard resulting in serious injuries or death. This warning is supplemented by a triangular hazard symbol.

**WARNING!**

The signal word WARNING identifies a potentially hazardous situation, which might result in serious injuries or death. This warning is supplemented by a triangular hazard symbol.

**CAUTION!**

The signal word CAUTION identifies a potentially hazardous situation, which might result in light injuries. This warning is supplemented by a triangular hazard symbol.

**ATTENTION!**

The signal word ATTENTION identifies a potentially hazardous situation, in which the product or property in the environment may be damaged. This warning is supplemented by a hazard symbol or an exclamation mark.

2.2 Intended use

This machine is a hose skiving machine for industrial use, only suitable for skiving wire-reinforced hydraulic hoses, see “Technical Data” in Section 3.

Intended purposes include:

- single workplace for one person only,
- single stroke with manual feed and withdrawal,
- operating temperature between 10 °C and 35 °C,
- operation in a closed room,
- The machine must not be operated by persons not capable of operating the machine without any risk. These may include:
 - persons with physical or mental disabilities;
 - children and persons under age;

2 Safety instructions

2.3 Product-specific risks

- persons with a restricted capability for the operation of machines (e.g. under the influence of drugs, alcohol or narcotics)

Use of the control in compliance with the intended purpose also includes compliance with the instructions in this Operation Manual.

Use for other than the intended purpose

Any other use is considered as being not in compliance with the intended purpose, in particular:

- design modification of the machine;
- use in explosive environments;
- use of impermissible skiving domes;
- use of impermissible skiving blades;
- skiving of workpieces with ripped out wires,
- skiving without safety equipment,
- misuse of consumables and waste materials.

WARNING!	
	<p>Risk for life and health!</p> <p>Use not in compliance with the intended purpose imposes risks for life and health. Consequences resulting from use for other than the intended purpose shall be under the sole responsibility of the owner.</p> <ul style="list-style-type: none">• Always use the machine in compliance with its intended purpose.

2.3 Product-specific risks

The machine/unit is designed in accordance with the latest state of technology. Nevertheless, the machine/unit may impose risks:

2.3.1 Risks imposed by mechanical equipment

Cutting risk

The skiving process and the skiving knife change-over imply a cutting risk.

2 Safety instructions

2.3 Product-specific risks

- Keep sufficient distance to the skiving knives during operation.
- Take care when changing the skiving knives and wear protective gloves.

Risk of squeezing

There is risk of getting squeezed between the protection cover and the chassis when closing the protection cover.

- Use the strap grip to close the protection cover.

Tilting hazard

The risk of tilting mainly exists while the machine is being transported.

- Observe the machine's centre of gravity during transport.

2.3.2 Risks imposed by electricity

There is a risk of electrocution near the live parts!

- Work on electric systems may only be performed by qualified electricians or instructed and trained persons under the supervision of a qualified electrician.
- Deactivate the machine/unit and secure it against unintentional restart before maintenance.

2.3.3 Risks imposed by noise

The noise level meter acc. to IEC 804, Class 2, was calibrated before measuring.

The operation of the machine/unit causes noise emissions of 60 dB(A) at the workplace. Noise protection is not required.

Higher noise emissions may occur when other machine/unitry is simultaneously used at the workplace. The machine/unit owner must provide for appropriate protection, e.g.

- instruct staff to wear ear protection,
- provide information/instructions on risks,
- identify hazardous areas,
- provide health monitoring.

2 Safety instructions

2.3 Product-specific risks

2.3.4 Risks imposed by substances

Oils, greases and emulsions may penetrate the skin. When handling hazardous substances, oils and greases, the manufacturers' safety instructions have to be observed. Apply skin protection appropriate for the hazardous substances used.

2.3.5 Risks in case of fire

The operating staff has to be familiar with the location as well as with operating the fire alarm and fighting means. Free access to this equipment must be ensured.

Use extinguishing powder in case of fire.

2 Safety instructions

2.4 Safety

2.4 Safety

2.4.1 Working area

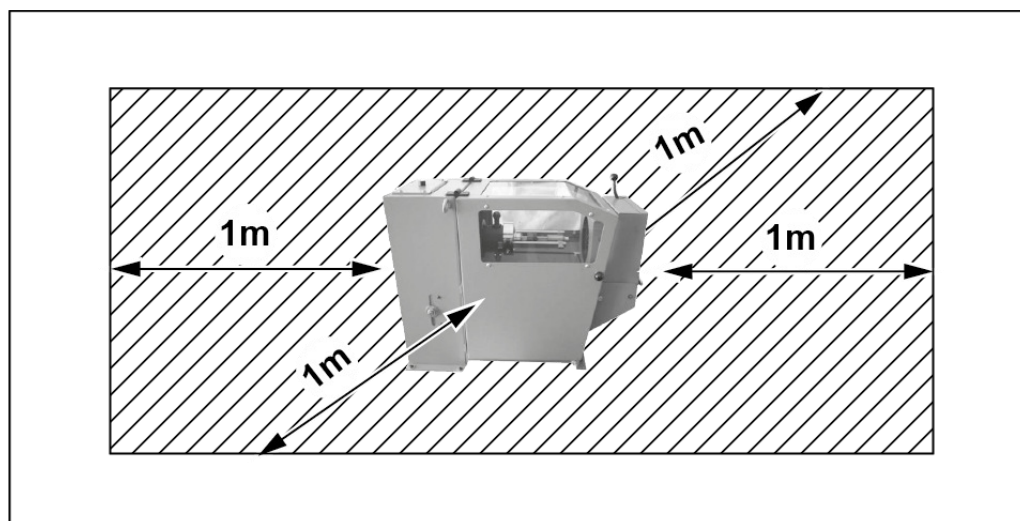

The working area is designed as the area 1 metre all around the machine (shaded).

- Keep the working area free from trip hazards
- Use ducts for lines and cables
- Provide good illumination

2 Safety instructions

2.4 Safety

2.4.2 Emergency-stop

The machine is fitted with an emergency-stop switch on the control panel.

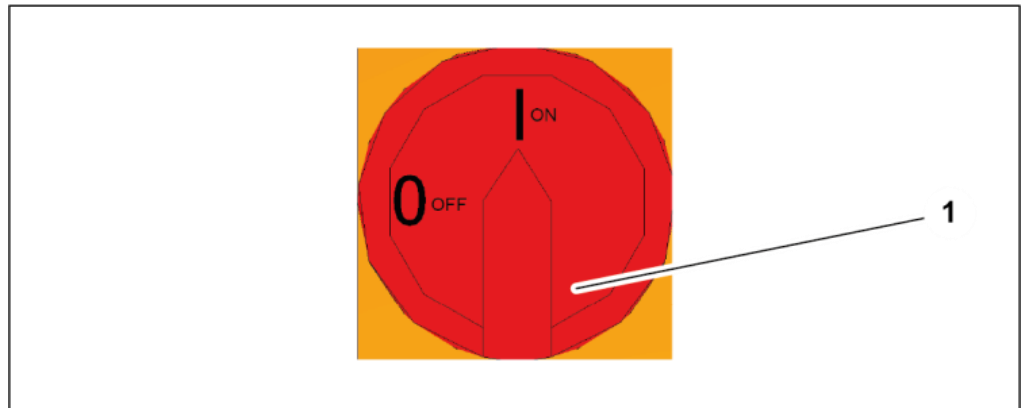

Immediately activate the emergency-stop switch (1) on the control panel in cases of emergency.

Remedy the cause of the emergency stop first before unlocking the emergency-stop switch.

2.4.3 Protection equipment



The protection hood (1) covers the skiving area of the unit and is fitted with a safety switch. The safety switch is closed by the

2 Safety instructions

2.4 Safety

contact plug when the protection hood is closed. The safety switch switches off the motor when the hood is opened.

DANGER!



Risk of injuries by manipulated safety switch

The manually operated protection cover is an essential safety feature of the machine.

- Never operate the machine with a non-functional safety switch.

The protective flaps (2) of the machine are mechanically pre-tensioned by springs. This force must first be overcome before the workpiece can be inserted into the skiving area. This protects the operator from unintentionally reaching into the danger area. The protective flaps can be opened via the "Emergency opening" lever (3).

2.4.4 Warning signs on the machine



Crushing risk
on the cover



Cutting risk
on the skiving knives



Danger from electric current
at the power supply line

Illegible or missing warning signs must immediately be replaced by the owner.

3 Machine description

3.1 Design and function

Basic machine

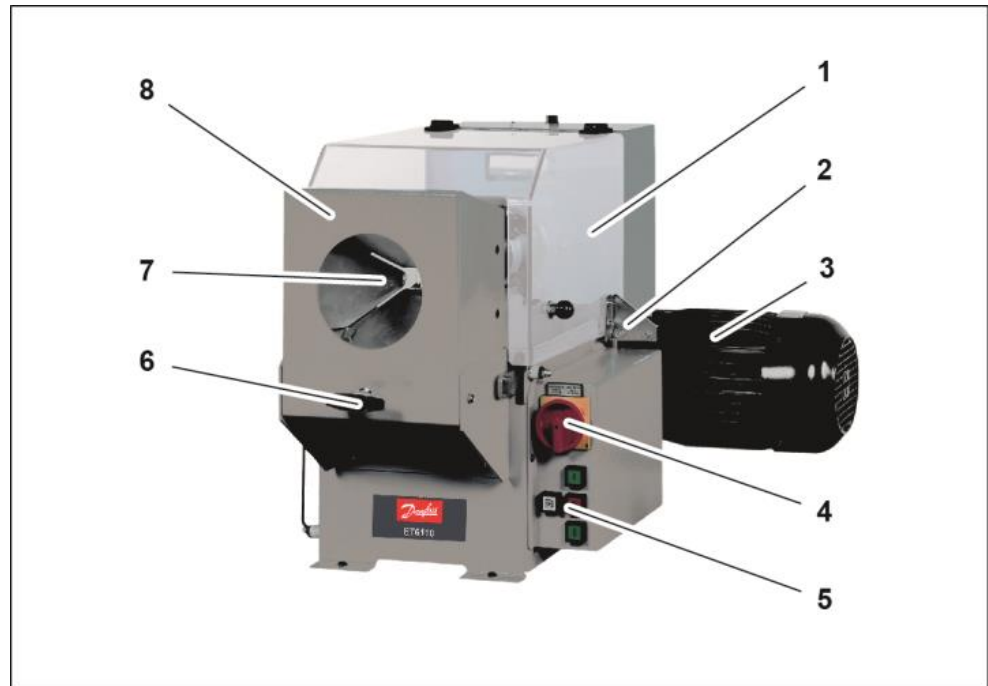

- (1) Protection hood
- (2) Safety switch
- (3) Electric motor
- (4) Main power switch
- (5) Control system
- (6) Opening lever
- (7) Protective flaps
- (8) Hose guide housing

With USM 100, hose lines with wire braiding up to DN 50 and hose lines with wire spiral up to DN 50 - 6 SP can be peeled inside and outside simultaneously.

The machine is bolted to a table (option) or other horizontal support. The skiving residues can be collected in a waste cart (option).

The hose is guided by hand through the protective flaps (7) centrally against the peeling blades. The hands remain outside the machine during this process. The motor operated skiving blades (3)

3 Machine description

3.2 Operation and display elements

rotate against each other and skive the hose line inside and outside simultaneously from the hose end. The skiving residues fall out laterally downwards and are collected by the trolley under the skiving machine. After skiving, the workpiece is removed by hand.

The skiving speed can be selected using the switch on the control panel.

3.2 Operation and display elements

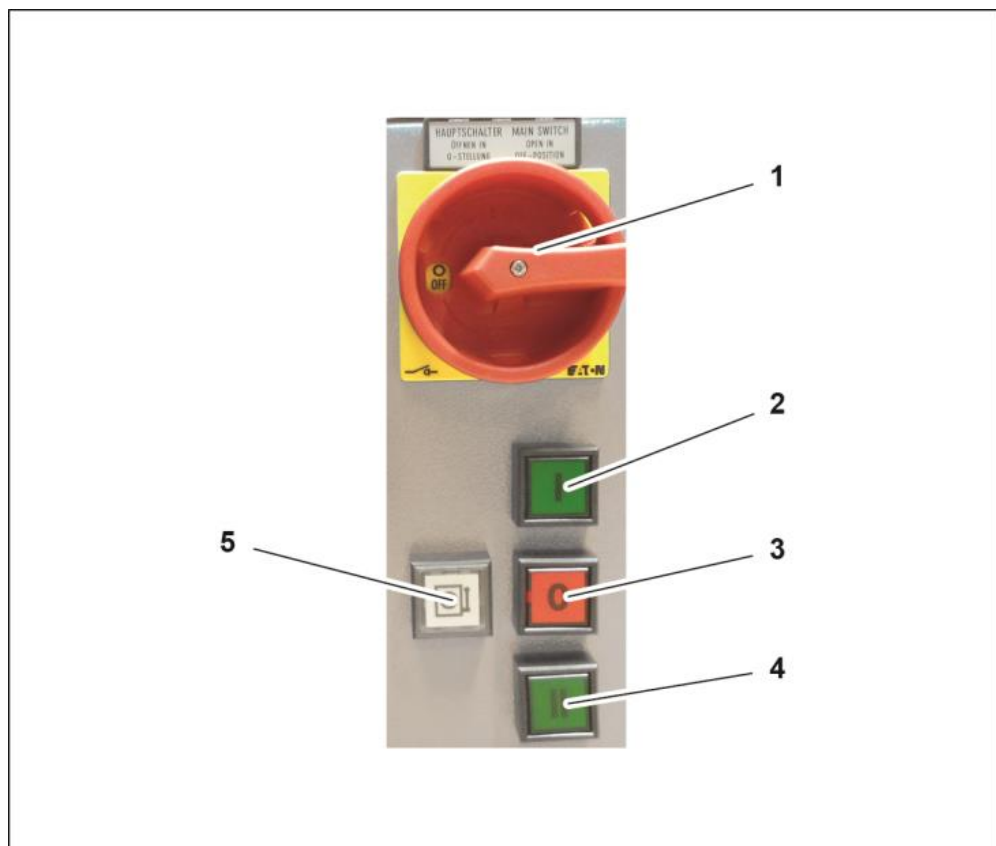

- (1) Emergency-stop switch / main switch
- (2) Button [I] Motor On (number of revolutions = 392 min-1)
- (3) Button [I] Motor Off
- (4) Button [I] Motor On (number of revolutions = 592 min-1)
- (5) Operating indicator light

3 Machine description

3.3 Technical data

3.3 Technical data

Machine

Dimensions L x W x H	440 x 440 x 545 mm
Weight	approx. 35 kg
Type of use	Workshop
Operation mode	S3-60 %
Noise level	< 70 dB(A)*
Protection class	IP 40

Function

Tool speed	110 rpm
------------	---------

Workpiece capacity

Inside skiving	5/8" - 2"
Outside skiving	3/16" - 2"

Electric connection

Connection power	0.37 kW
Connected voltage	400 V 50 Hz, 3 phase+PE
Back-up fuse	16 A delayed

Gear oil

Oil volume	approx. 100 ml
Oil type	Shell Omala Oil 220

Workbench

Solid, plane workbench with a carrying capacity of	approx. 500 kg
--	----------------

3 Machine description

3.3 Technical data

We recommend industrial flooring meeting the following structural requirements

Permanent floor loading	Approx. 0.07 kg/mm ²
Floor carrying capacity	Min. 1000 kg/m ²
Floor quality	B25
Evenness	Max. unevenness 5 mm/m
Inclination	max. 5 mm/m

Ambient conditions

Ambient temperature	10 °C – 35 °C
Air humidity	45 % – 65 %

The *data are theoretical/computed values, or values measured on a prototype. Actual values may vary slightly, depending on the machine.

4 Transport and commissioning

4.1 Transport

4 Transport and commissioning

4.1 Transport

The goods should be transported in the original packaging. During transport, the goods must be secured safely within the packaging. All applicable laws and regulations relating to securing loads shall be observed during transport.

The machine must only be unloaded and transported with a crane. When a crane is used for transport, lifting gear with a sufficient length and lifting capacity has to be used. For machine weight, please refer to "Technical data" in Section 3.

WARNING!



Danger from falling loads!

Risk of injury from falling loads.

- Do not stand under suspended loads.

WARNING!



Danger from tilting machine!

The machine may tilt if it is transported improperly. There is a risk of being injured.

- Consider the machine's centre of gravity.
- Only lift the machine at the designated points.

1. Lift the machine using the lifting lug and transfer it to the installation site.

4.2 Intermediate storage of machine/unit

If the machine/unit cannot be mounted immediately upon delivery, it must be protected against:

- Contamination,
- Weather influences,

4 Transport and commissioning

4.2 Intermediate storage of machine/unit

- Mechanical damage.

The machine/unit components may only be stored in closed rooms and under the following conditions:

- temperature between 10°C and 35°C,
- maximum air humidity 80% (non-condensating).

4.3 Commissioning

The machine is commissioned by the customer's fitter.

1. Place the machine on a stable and level workbench.
2. Bolt the machine legs onto the workbench.



The workbench must be sufficiently solid and stable.



Place the machine in a way so that it is easily accessible for maintenance work from all sides.

3. Check the machine for damage.
4. Check the electric cables for damage.
5. Train the operating staff and record training sessions in "Declaration of trained staff", Section 9.

WARNING!



Risk of injuries!

Machine components might loosen during transport. Such components might be flung out during the skiving process. There is a risk of being injured.

- Simulate the skiving process several times without a work piece.
- Check the machine for atypical noise.

WARNING!



Risk of injuries!

Pay attention to the cutting edges at all operations on the knives.

- Wear safety gloves.

4 Transport and commissioning

4.3 Commissioning

4.3.1 Inserting the internal skiving mandrel

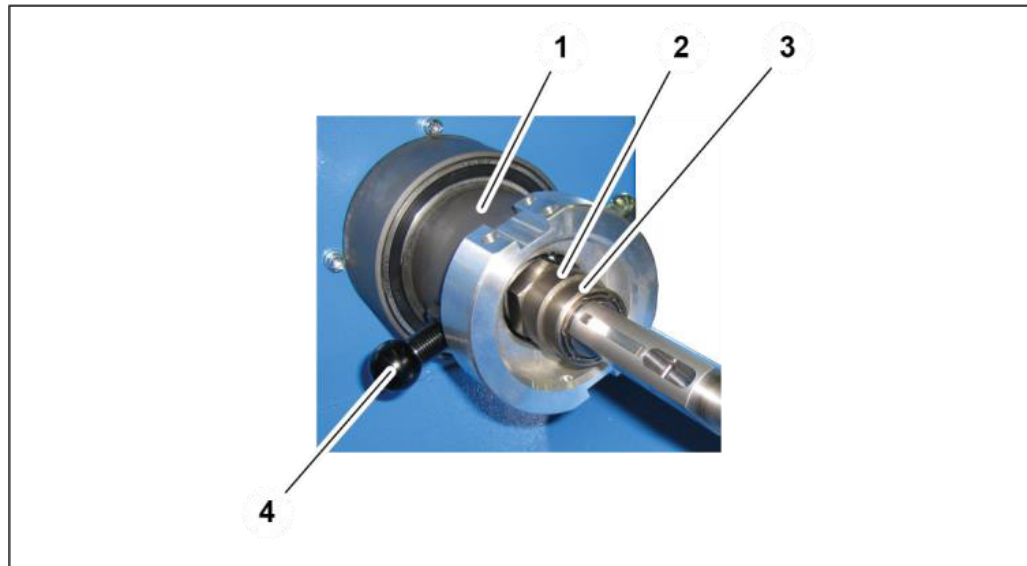

1. Select the correct internal skiving mandrel (if several available) for the hose diameter.
2. Push the stop sleeve (2) back on the internal knife holder (3) and hold.
3. Insert the internal skiving mandrel as far as possible into the internal mandrel holder (3).
4. Turn the internal skiving mandrel until it can be pushed a little further.
5. Release the stop sleeve (2).
6. Turn the internal skiving mandrel until it engages audibly. The internal mandrel has to fit tight in the holder.

4 Transport and commissioning

4.3 Commissioning

4.3.2 Setting the internal skiving diameter

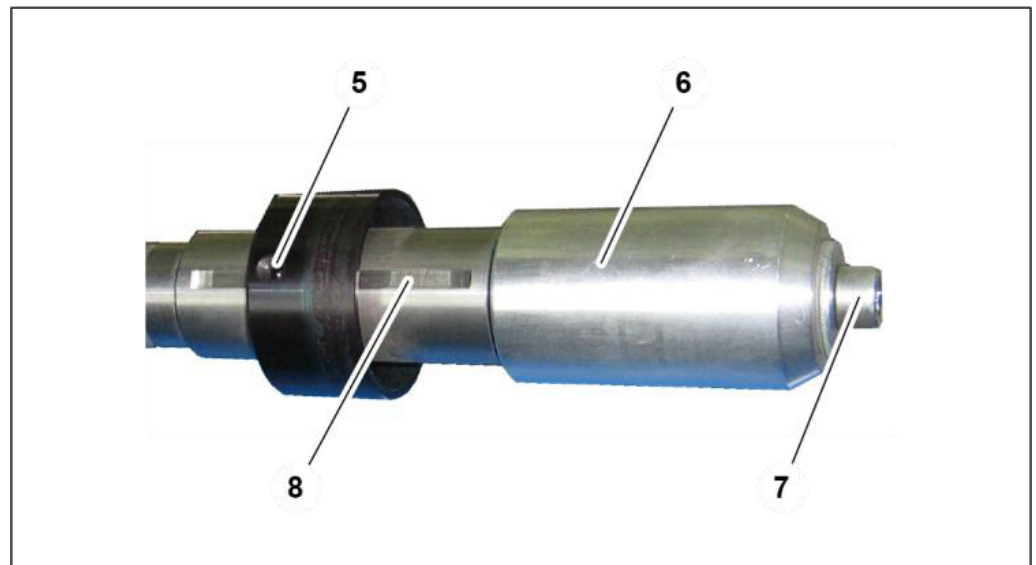

1. Hold the skiving spindle.
2. Remove the screw (7) in the tip of the skiving spindle.
3. Assemble the centering sleeve (6) that is specified for this diameter.



Assemble the right corresponding centering sleeve (6), depending on the nominal diameter of the hose assembly.

4. Screw in the loosened screw (7) – do not tighten it.
5. Adjust the internal skiving diameter by turning the setting screw (5).
6. Fasten the screw (7) in the tip of the skiving spindle.
7. Check the skiving diameter, adjust if necessary.

4.3.3 Inserting the external skiving tool

1. Select the correct external skiving tool (if several available) for the hose diameter.
2. Pull the stop lever (4) on the knife holder (1) upwards and hold it.
3. Insert the external skiving knife as far as possible into the external knife holder (1).

4 Transport and commissioning

4.3 Commissioning

4. Release the stop lever (4).
5. Turn the external skiving knife until it audibly engages. Examine its tight fit. The external knife has to fit tight in the holder.

4.3.4 Adjusting the external skiving diameter

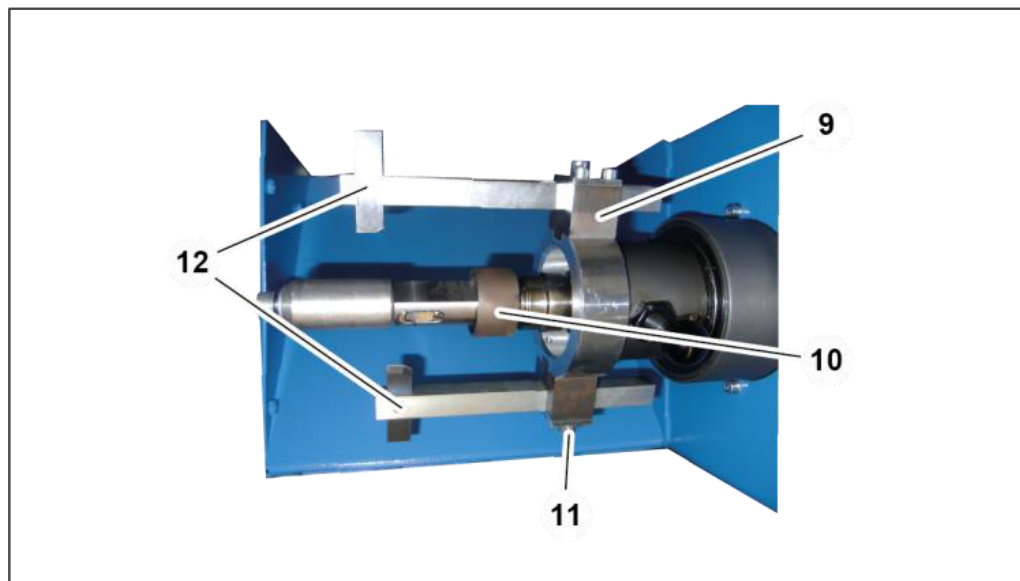

1. Open the protection hood.
2. Loosen the screws (12) on the knife holder.
3. Move the knife until the correct outer diameter is reached.
4. Retighten the loosened screws (12).
5. Repeat the steps to adjust the opposing knife.
6. Check the distance between the two knives.

4.3.5 Adjusting the external skiving depth

1. Assemble depth stop (10) depending on the skiving diameter.
2. Loosen the screw (11) on the knife holder of the external knife.
3. Move the knife holder (9) until it reaches the right skiving depth.
4. Repeat the steps to adjust the opposing knife.
5. Retighten the loosened screws (11).

4 Transport and commissioning

4.3 Commissioning

4.3.6 Electrical connection

WARNING!



Risk by electrical voltage!

There is a risk of electrocution near the live parts!

- Work on electric systems may only be performed by qualified electricians or instructed and trained persons under the supervision of a qualified electrician.
- Do not operate the machine without a sufficiently rated ground wire.
- Deactivate the machine and secure it against unintentional restart before maintenance.

1. Disconnect the power supply for the machine and secure it against unintentional restart.
2. Have the power cable of the machine connected to the local mains by a qualified electrician according to the regulations of the Electricity Board.



The permissible voltage frequency ranges and the relevant motor protection setting are also indicated on the nameplate..

3. Check rotation direction of motor (only for three-phase connection). If the rotation direction of the motor is incorrect, the rotation direction will be the opposite to the marking on the change in direction of rotation switch.

5 Operation

5.1 What you have to observe

5 Operation

5.1 What you have to observe

The operator has received the Operation Manual from the owner, has read and understood it and will observe it.

Before starting and/or re-starting

- Ensure sufficient illumination of the working area of the machine/unit.

During operation

- Observe the safety instructions on the machine/unit.
- Make sure that no other persons stay in the working area.
- Use appropriate aids to handle heavy workpiece.
- Each movement of the hand must be observed.
- The control cabinet must be closed securely.
- Eating, drinking and smoking at the workplace is prohibited.
- Wear close-fitting clothes.
- Do not wear watches or jewellery.

5.2 Start

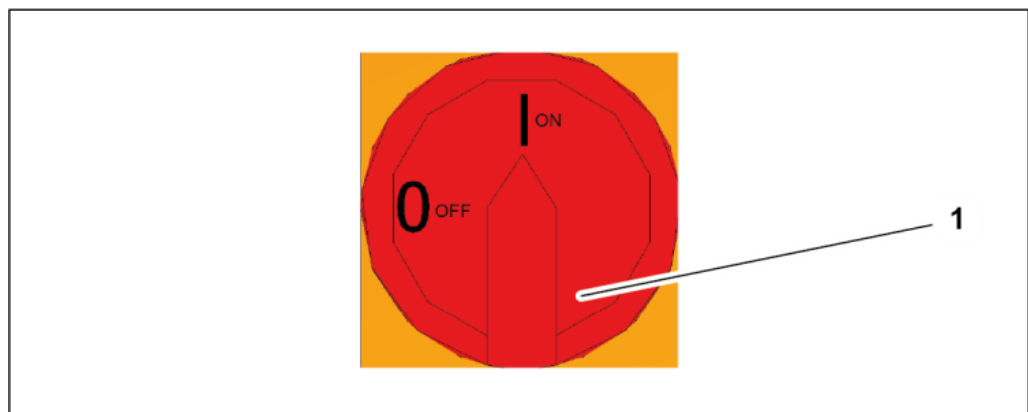

1. Check that there is no emergency-stop situation.
2. Activate the power switch (1).

5.3 Skiving the workpiece

5.3.1 Prerequisites

Prerequisites for a correct skiving process:

- A suitable outside/inside skiving tool is selected.
- The outside/inside skiving tool is inserted in the drive shaft.
- The outside/inside skiving tool is secured by the locking pin / star-shaped grip.
- The skiving length is set, see “Adjusting the skiving knives” in Section 5.
- The protection hood is closed.

5.3.2 Skiving the workpiece

WARNING!	
	<p>Cutting risk</p> <p>There is risk of cutting your extremities when skiving work piece.</p> <ul style="list-style-type: none">• Do not reach into the skiving area during operation.

1. Slot the hose in longitudinal by using the hose slot unit (optional).
2. Close the protection cover.
3. Turn the main switch on.
4. Press the green button for the selected skiving speed (I or II) at the control panel.
5. The skiving tool starts rotating.
6. Insert the workpiece through the safety flaps into the skiving tool and push it axial against the knife.
7. The workpiece is skived.
8. Pull the workpiece out of the mandrel.
9. Press the red button at the control panel.
10. Pull the skived workpiece out of the skiving machine.

5 Operation

5.3 Skiving the workpiece

5.4 Stop

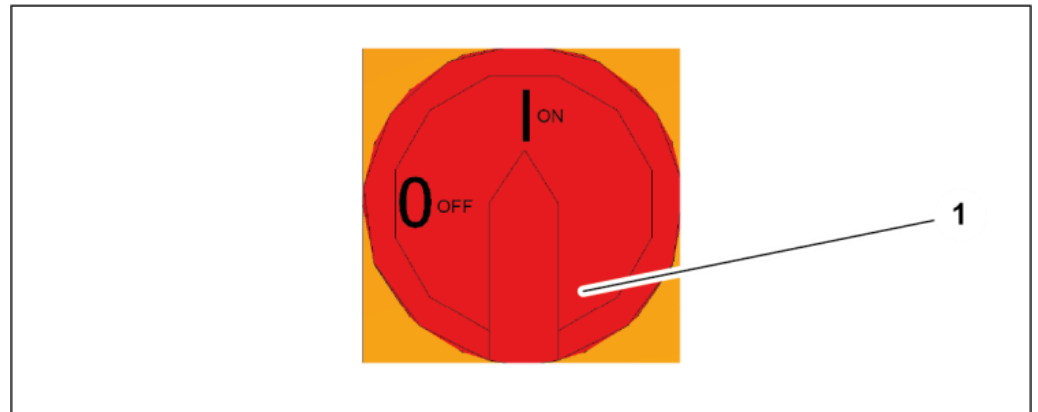

1. Complete the skiving process.
2. Deposit the workpiece outside the machine.
3. Deactivate the main power switch (1) and secure it against unintentional restart.
4. Open the protection cover.
5. Empty the chip box.
6. Check the machine for contamination and outside damage.
7. Check the skiving knife for damage and wear.
8. Remove contamination and dust using a vacuum.



Inform the fitter in case of damage or other irregularities.

5.5 Emergency-stop

In case of an emergency

Immediately deactivate the emergency-stop switch in cases of emergency. The motor is switched off immediately. The skiving tool movement is stopped.

Restart after an emergency

WARNING!



Risk of injuries!

The emergency-stop button was probably activated due to the occurrence of a hazardous situation. A restart of the machine may cause injuries if the hazardous situation has not yet been remedied!

- Remedy the hazardous situation before a restart.

1. Remedy the cause of the emergency stop.
2. Activate the emergency-stop switch.

5.6 Cleaning

ATTENTION!



Risk of damage to machinery!

If the machine is cleaned with a steam jet or compressed air, dirt and water may ingress in the machine and cause serious damage.

- Do not use a steam jet to clean the machine.
- Do not use compressed air to clean the machine.

1. Empty the chip box.
2. Use a vacuum cleaner or a soft cloth to clean the machine.

6 Maintenance

6.1 What you have to observe

6 Maintenance

Regular maintenance will ensure the continuous operation reliability of the device.

6.1 What you have to observe

This Section describes action to be taken by you as the fitter regularly to ensure the troublefree use of the machine/unit.

- Maintenance work may only be performed by qualified maintenance staff (machine/unit fitters).
- Repair work on the machine/unit or components may only be performed by appropriately qualified expert staff or UNIFLEX experts!
- The machine/unit must always be deactivated during maintenance work (see "Deactivation" in Section 5). Use the lock to prevent the main switch from being switched on and also attach a sign. Example text:

Machine/unit out of service for
maintenance work!
Do not switch on!

- Welding, flame-cutting and grinding work on and in the machine/unit and its environment must be approved in advance. There is a risk of fire. The machine/unit must be cleaned from dust and inflammable substances. Adequate ventilation must be ensured.

6.2 Maintenance schedule

If not specified otherwise, inspections listed in the maintenance schedule are visual inspection. Replace defective parts.

If you work in 2 shifts, the check frequency has to be doubled. If you work in 3 shifts, you proceed as with 2-shift operation.

Record maintenance work performed in the maintenance log.

6 Maintenance

6.2 Maintenance schedule

Maintenance item	Weekly	Monthly	Every 6 months	Number of years
Skiving knife				
Check skiving knife - for sharpness, cracks and breakouts; resharpen or replace knives as appropriate.	X			
Bolted connections: To be checked and retightened, if required.		X		
Machine - Clean	X			
Safety equipment				
Emergency-stop switch. Check function.	X			
Safety switch: Check function.	X			
Check permanently installed partitioning protection equipment and covers for completeness and correct installation.		X		
Warning signs on machine: Check legibility (see "Warning signs on the machine" in Section 2).			X	
Protective screens have to be replaced five years after manufacture (see year of construction) at the latest.				5





The replacement of wear parts must be recorded in the maintenance log!

6 Maintenance

6.3 Replacing the skiving knives

6.3 Replacing the skiving knives

WARNUNG!	
	<p>Risk of cutting!</p> <p>There is an acute risk of injury to the hands when changing the knife.</p> <ul style="list-style-type: none">• Wear safety gloves when working on the knives.

WARNUNG!	
	<p>Risk by electrical voltage!</p> <p>There is a risk of electrocution near the live parts!</p> <ul style="list-style-type: none">• Deactivate the machine and secure it against unintentional restart before maintenance.

6.3.1 Removing the external skiving tool

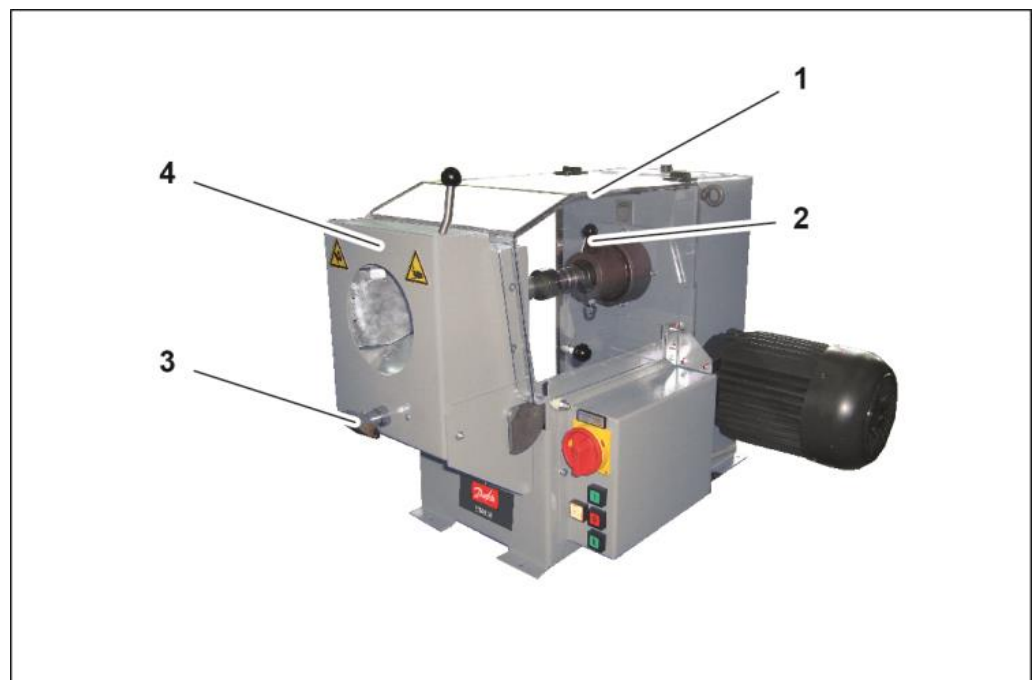

1. Open the protective hood (1).

6 Maintenance

6.3 Replacing the skiving knives

2. Hold the hose guide (4) and turn the opening lever (3). This unlocks the retaining bolts of the hose guide (4).
3. Carefully tilt the hose guide (4) downwards.
4. Release the locking lever (2) of the skiving tool.
5. Pull the skiving tool forward out of the shaft.

6.3.2 Replacing the external skiving knife

ATTENTION!



Risk of damage to machinery!

Worn skiving knives may cause damage to the machine and skiving inaccuracies.

- Check the skiving knives daily.

1. Loosen the screws in the knife holders.
2. Remove the knife and replace it with a new and/or sharpened knife.
3. Fasten the loosened screws.

6 Maintenance

6.3 Replacing the skiving knives

6.3.3 Replacing the internal skiving knife

ATTENTION!



Risk of damage to machinery!

Worn skiving knives may cause damage to the machine and skiving inaccuracies.

- Check the skiving knives daily.

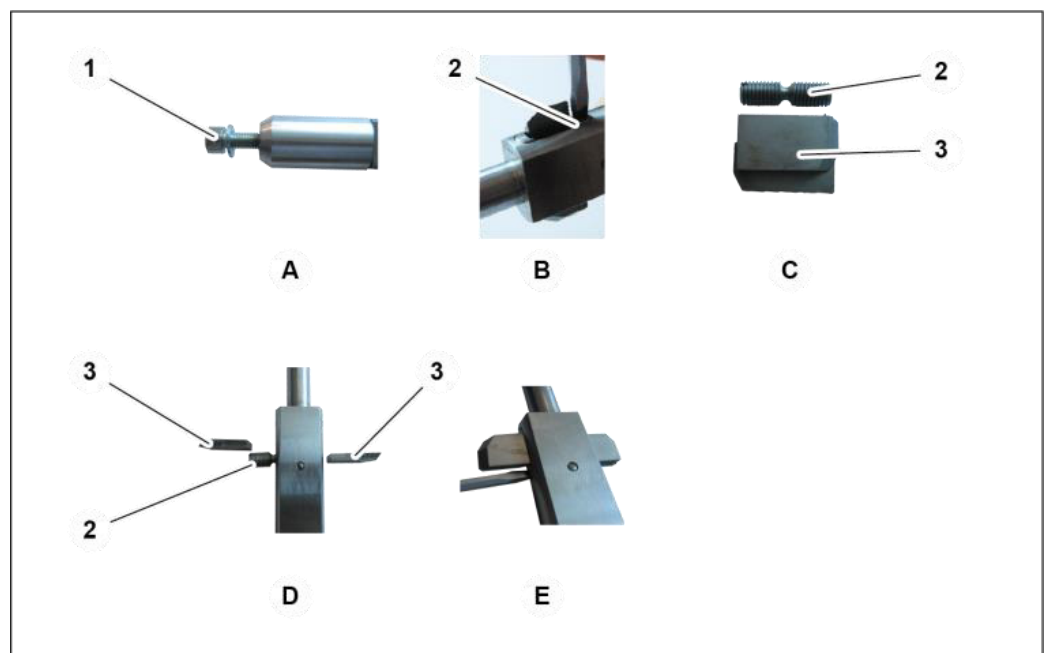

1. Loosen the screws (1) (Figure A).
2. Take out the skiving knife by loosening the setting screw (2) (Figure B).
3. Replace old knives with new and/or sharpened knives.
4. The skiving knives (3) are identified with L or R for left or right thread (Figure C).
5. The skiving knife with the identification L must be mounted on the side of the left-threaded setscrew (Figure D).
6. The skiving knife with the identification R must be mounted on the side of the right-threaded setscrew (Figure D).
7. Turn the setting screw (2) to tighten the skiving knives (Figure E).
8. Retighten the loosened screw (1).

6 Maintenance

6.4 Changing break pads

9. Check the adjusted diameter.

6.4 Changing break pads



Exchange any abraded break pads, if the break pad is thinner than 2 mm.

1. Loosen the rear cover plate.
2. Loosen the two screws of each break pad.
3. Insert new break pads and re-fasten with the two screws.

7 Troubleshooting

Error	Cause	Remedy
Machine does not skive	Power switch is OFF	Activate the power switch
	Voltage incorrect	Check voltage supply
	Power plug defective	Check power plug and replace, if required
	Incorrect rotation direction of electric motor	Check rotation direction, correct electrical connection
	Foot pedal not connected to socket	Check cable connection between foot pedal and machine.
	Foot pedal is defective	Check the foot pedal and replace it, if required
Machine operates sluggishly	Skiving knives are worn	Check skiving knives for wear and replace them, if required
Skiving result is inadequate	Skiving knives are worn	Check skiving knives for wear and replace them, if required

8 Decommissioning, disposal

WARNING!



Risk by electrical voltage!

There is a risk of electrocution near the live parts!

- Shut down the machine/unit.
- Disconnect the machine/unit from the power supply.

CAUTION!



Risk of injuries!

Contact with hydraulic oil and other consumables imposes a risk of injuries for the skin, eyes, respiratory and intestinal tracts! Hydraulic liquid spills impose danger of slipping and falling!

- Observe supplier's protection and safety instructions (see data sheet).
- Wear personal protection equipment.
- Do not eat, drink or smoke in the working area and when handling consumables.
- Ensure good ventilation.
- Avoid floor contamination.

ATTENTION!



Risk of fire!

Hydraulic liquid spray or spills imposes a risk of fire.

- Avoid ignition sources (welding, cutting and soldering work) near the hydraulic oil filling.

CAUTION!



Risk of injuries!

Parts of the machine/unit may be under pressure and/or tension. Loosening components may impose a risk of injuries!

- De-pressurize the machine/unit before performing any work and check for potential sources of hazard.

8 Decommissioning, disposal

8.1 Dismantling

8.1 Dismantling

This section describes activities to be performed by you as the operator to ensure the safe dismantling of the machine/unit.

- The machine/unit may only be dismantled by entrusted and qualified staff.
- Open the machine/unit completely.
- Depressurise the machine/unit before dismantling it (deactivate the hydraulic pump and secure it against restart; operate valve manually, if any; open bolted hydraulic connections slowly and carefully).
- Check the machine/unit for mechanical tension and consider it during dismantling.
- Empty the machine/unit of all consumables, see “Maintenance”, Section 6.

8.2 Recycling

The machine/unit contains metal, hydraulic hoses, electric cables and electronic components, depending on the type.

As regards disposal, the applicable national environmental protection and waste disposal regulations have to be complied with.

8.3 Consumables and waste

Observe applicable national environmental protection and waste disposal regulations.

Return consumables, e.g. oils, greases, test media, to supplier - they are hazardous waste. Also observe the information given on the safety data sheet.

9 Annex

9.1 Accessories (retrofitable)

9 Annex



Individual machine/unit components may deviate in their features. Please indicate the serial number of the machine for spare part orders.

9.1 Accessories (retrofitable)

Accessories	Article code
Workbench	TU
Hose slitting machine	SSG
Drill DN 6 ID ¼	UIT 6
Drill DN 8 ID 5/6	UIT 8
Drill DN 10 ID 3/8	UIT 10
Drill DN 12 ID ½	UIT 12
Drill DN 16 ID 5/8	UIT 16
Internal skiving tool DN 20 ID ¾	UIT 20
Internal skiving tool DN 25 ID 1	UIT 25
Internal skiving tool DN 32	UIT 32
Internal skiving tool DN 40	UIT 40
Internal skiving tool DN 50	UIT 50
Internal skiving tool DN 60	UIT 60
External skiving tool	UOT 06-50
External skiving tool DN 60	UOT 60
Adjustment mandrel DN 06	UOP 06
Adjustment mandrel DN 08	UOP 08
Adjustment mandrel DN 10	UOP 10
Adjustment mandrel DN 12	UOP 12
Adjustment mandrel DN 16	UOP 16
Adjustment mandrel DN 20	UOP 20
Adjustment mandrel DN 25	UOP 25
Adjustment mandrel DN 32	UOP 32
Adjustment mandrel DN 40	UOP 40

9 Annex

9.1 Accessories (retrofittable)

Accessories	Article code
Adjustment mandrel DN 50	UOP 50
Adjustment mandrel DN 60	UOP 60

Please contact our Sales Department for ordering optional accessories.

9.2 Spare parts list

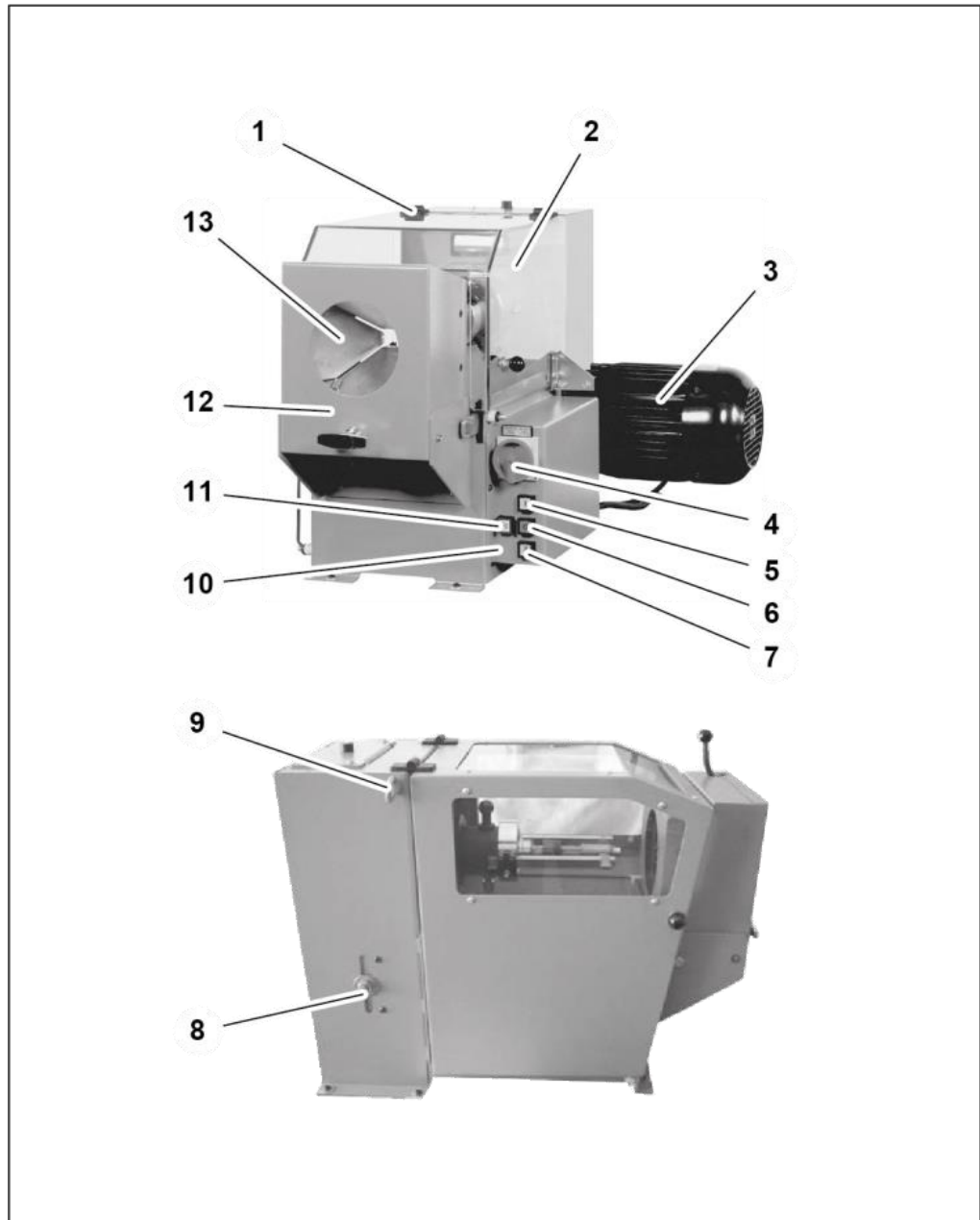

Item	Quantity	Part code	Designation
1	2	307.026	Hinge
2	1	307.225.1	Macrolon safety glass
3	1	307.027	Electric motor
4	1	T0-2-1/ea/SvB	Main switch

9 Annex

9.2 Spare parts list

Item	Quantity	Part code	Designation
5	1	QXT + BSOX 43 + T25F GN	Button motor on I
6	1	QXT + BSOX 42 + T25F RT	Button motor off
7	1	QXT + BSOX 44 + T25F RT	Button motor on II
8	1	M 12 DIN 982 + DIN 9021 Ø13	Nut + Washer
9	2	DIN 580 M 8	Screw
10	1	307.400	Control
11	1	QXLS-KL / X1112/T5,5 K/24	Indicator light
12	1	307.017	Toggle handle
13	4	307.016.3	Guide plate

9 Annex

9.2 Spare parts list

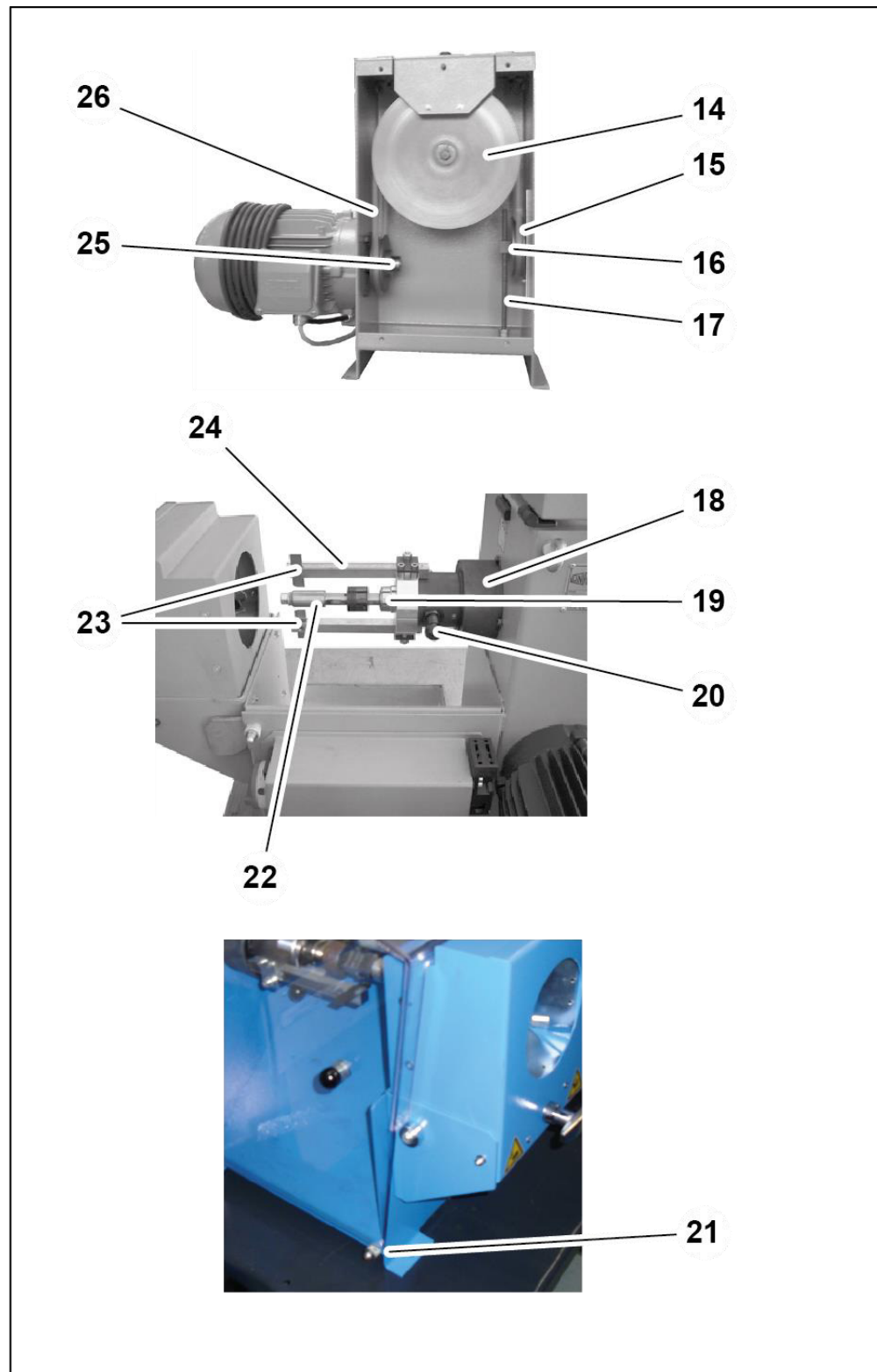

Position	Anzahl	Artikelnummer	Bezeichnung
14	1	307.257.3	Pulley
15	1	307.032.4	Tensioner

9 Annex

9.2 Spare parts list

Position	Anzahl	Artikelnummer	Bezeichnung
16	1	307.012.4	Pulley
17	1	DIN 975 M 10x245	Threaded rod
18	1	307.006.3	Socket
19	1	307.012	Coupling socket
20	1	307.005	Locking bolt
21	2	307.040	Round spring
22	1	UITxx	Internal skiving mandrel
	1	UOPxx	Internal holding mandrel
23	2	307.053.4	External skiving blade
24	1	UOT 06 – 50	External skiving tool
25		307.007.4	Belt pulley
26	1	307.002	Round belt

9 Annex

9.3 Spare parts set

9.3 Spare parts set

Quantity	Part code	Designation
1	307.053	Spare part set

9 Annex

9.4 Electric diagram

9.4 Electric diagram

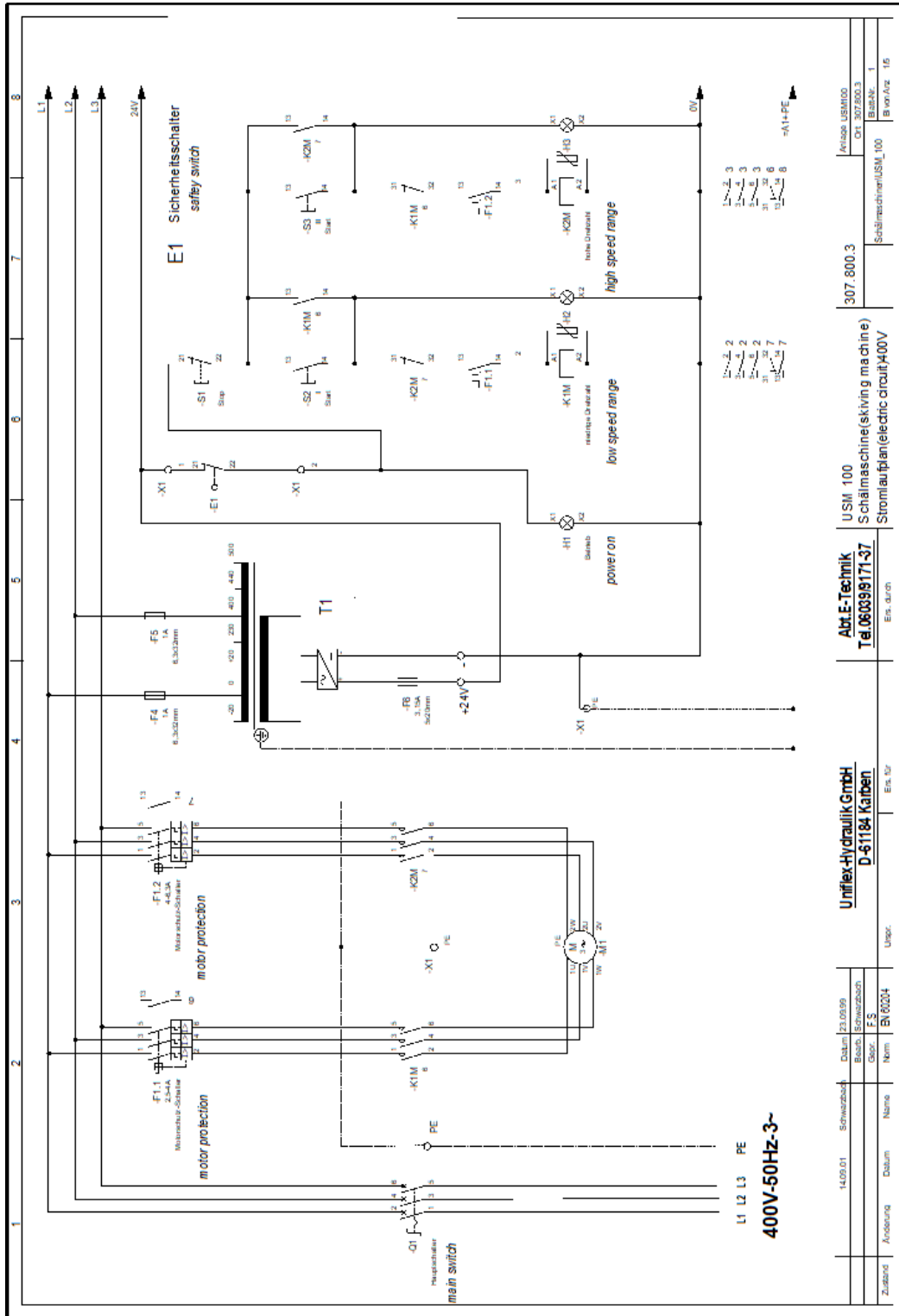

9 Annex

9.6 Declaration of qualified staff

9.6 Declaration of qualified staff

I herewith declare that I have attended an internal training for the operation of the UNIFLEX machine and have been informed on all safety-related details. In addition I declare that I have read and understood this Operation Manual completely.

--	--	--	--

City

Date

Name

Signature

--	--	--	--

City

Date

Name

Signature

--	--	--	--

City

Date

Name

Signature

--	--	--	--

City

Date

Name

Signature

--	--	--	--

City

Date

Name

Signature

--	--	--	--

City

Date

Name

Signature

9 Annex

9.6 Declaration of qualified staff

About Danfoss Power Solutions FC

We sincerely appreciate your choice in selecting this product as part of the range of tooling products distributed by Danfoss.

Danfoss hoses, fittings, and tooling provide the ultimate fluid conveyance solutions for a variety of equipment and applications around the world. We proudly engineer to support a sustainable future for tomorrow.

To learn more please visit: <http://www.danfoss.com/en/about-danfoss/our-businesses/power-solutions>

Danfoss Power Solutions

14615 Lone Oak Road
Eden Prairie, MN 55344, USA
Phone: 952-937-9800

Danfoss Power Solutions II GmbH

Fluid Conveyance
Dr. -Reckeweg-Str. 1
DE-76532 Baden-Baden
Tel.: +49 7221 6820
Machine and tooling selection hotline: FcMachineSupportEMEA@danfoss.com
Service and repair Hotline: FcMachineRepairsEMEA@danfoss.com

Danfoss Power Solutions (US) Company

2800 East 13th Street
Ames, IA 50010, USA
Phone: +1 515-239-6000

Danfoss Power Solutions GmbH & Co.OHG

Krokamp 35
D-2439 Neumünster, Germany
Phone: +49 4321 871 0

Danfoss Power Solutions ApS

Nordborgvej 81
DK-6430 Nordborg, Denmark
Phone: +45 7488 2222

Danfoss Power Solutions Trade (Shanghai) Co. Ltd.

Building #22, No 1000 Jin Hai Rd
Jin Qiao, Pudong New District
Shanghai, China 201206
Phone: +86 21 3418 5200w

Thank you for participating in the Danfoss tooling program. We are pleased to offer you high-quality tooling machines manufactured by our trusted partner, Uniflex. These machines are designed to meet the rigorous standards of our industry, ensuring reliability, precision, and efficiency in your operations. We are committed to providing you with the best tools to support your success.