

Data Sheet

PLUS+1[®] Controllers

MC050-110 and MC050-112



Mobile machine management

The MC050-110 and MC050-112 controllers are elements of the flexible, powerful, expandable, and affordable PLUS+1[®] family of mobile machine management products. These devices are general-purpose controllers that are equally suited for use as members of a distributed machine control system, with intelligence in every node, or as stand-alone controllers.

Product highlights

The MC050-110 employs a 32 bit Cortex-M3 Processor, providing the controller with extremely fast single cycle processing speed and 512K internal flash. The MC050-112 has an application key that enables the use of Danfoss developed GUIDE machine control solutions. The same GUIDE HWD file is used with both controllers.



Application development

Users develop MC050-110 and MC050-112 applications with PLUS+1[®] GUIDE. This Microsoft[®] Windows[®] based development environment features a user-friendly, field proven, icon-based graphical programming tool, application downloader, and service/diagnostic tool.

Features

- User-programmable with PLUS+1[®] GUIDE (Graphical User Integrated Development Environment)
- 50 pins: (1) DEUTSCH DRC connector
- ARM 32 bit Cortex-M3 running at 120 MHz
- FRAM non-volatile memory
- 12 bit analog-to-digital converter
- 9 to 36 Vdc power supply, monitored internally
- 2 CAN 2.0 B ports, the fixed range analog inputs can be used as the shield pin
- Power supply for external sensors rated at 5 Vdc to 450 mA, monitored and regulated internally
- 2 LEDs under user control
- 3 mounting alternatives: stack, end, or side
- MC050-112 contains application key required to run Danfoss developed machine control application software
- CE compliant

Comprehensive technical literature is online at www.danfoss.com

22 inputs

- (6) universal (DIN/AIN/FreqIN) that are user-defined as either:
 - Analog: with configurable ranges 0 to 5.25 Vdc (with over range protection) or 0 to 36 Vdc
 - Digital: pull up (5 Vdc), pull down (0 Vdc) or pull to center (2.5 Vdc)
 - Frequency (timing): 1 Hz to 10 kHz
- (6) digital (DIN) configurable as pull up (5 Vdc), pull down (0 Vdc)
- (4) digital/analog (DIN/AIN) that are user defined as either:
 - Digital: pull up (5 Vdc), pull down (0 Vdc) or pull to center (2.5 Vdc)
 - Analog: 0 to 5.25 Vdc or 0 to 36 Vdc
- (4) analog (AIN/Temp/Rheo) 0 to 5.25 Vdc or 0 to 10,000 ohm rheostat
- (2) fixed range analog (AIN/CAN shield) 0 to 5.25 Vdc or CAN shield pin

16 Outputs

- (10) universal (PWMOUT/DOUT/PVGOUT) that are user-defined as either:
 - Digital: (3 A), configurable as source or sink
 - PWM: (30 to 4000 Hz), configurable as open or closed loop with current control
 - Analog voltage: open loop PWM at 4000 Hz
- Any PWMOUT/DOUT/PVGOUT can be used to provide reference power to one PVG valve
- (3) digital (DOUT) (3 A), configurable as source only
- (3) digital/PVG power supply (DOUT/PVG Pwr) (3A), user-configurable; one DOUT/PVG Pwr willpower up to three PVGs

Data Sheet
MC050-110 and MC050-112 Controllers

Dimensions

mm [in]

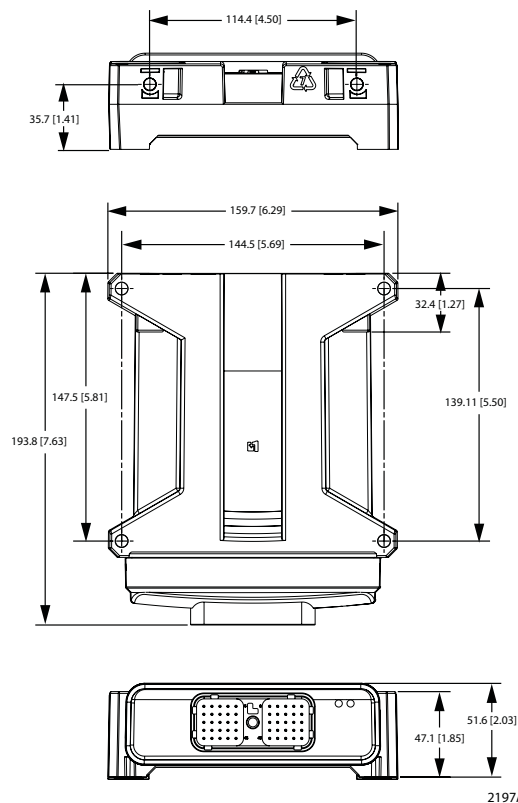

Caution

PCB damage may occur. All device power supply + pins must be connected to battery +.
 This device is not field serviceable. Opening the device housing will void the warranty.

Technical Specifications

Supply voltage	9 to 36 Vdc
Operating temperature (ambient)	-40°C to 70°C [-40°F to 158°F]
Storage temperature	-40°C to 85°C [-40°F to 185°F]
Programming temperature	-40°C to 70°C [-40°F to 158°F]
IP rating (with mating connector attached)	IP 67
EMI/RFI rating	100 V/M
Weight	0.53 kg [1.16 lb]
Vibration	IEC 60068-2-64
Shock	IEC 60068-2-27 test Ea
Maximum current, sourcing	40 A
Maximum current, sinking	8 A

Ordering information

MC050-110	11130954	
MC050-112	11130955	
Related product	Danfoss material number	
CG150 CAN/USB Gateway	11153051	
DEUTSCH mating connector bag assembly	10102024 (16 to 20 AWG)	10100946 (20 to 24 AWG)
PLUS+1® GUIDE and Service Tool Professional license	11179523	

Pin information

50-pin connector

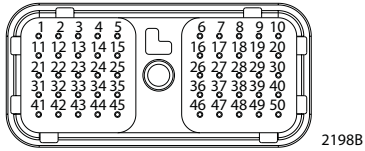

2198B

Pin	Controller function	Pin	Controller function
C1-P1	Power ground -	C1-P26*	DIN/AIN/FreqIN
C1-P2	Power supply +	C1-P27	AIN/Temp/Rheo
C1-P3	CAN0 +	C1-P28	AIN/Temp/Rheo
C1-P4	CAN0 -	C1-P29	AIN/Temp/Rheo
C1-P5	AIN/CAN0 shield	C1-P30	AIN/Temp/Rheo
C1-P6	DIN	C1-P31	DOUT
C1-P7	DIN	C1-P32	DOUT
C1-P8	5 Vdc sensor power +	C1-P33	DOUT
C1-P9	Sensor power ground -	C1-P34	DOUT/PVG Pwr
C1-P10	DIN	C1-P35	DOUT/PVG Pwr
C1-P11	DIN	C1-P36	DOUT/PVG Pwr
C1-P12	DIN	C1-P37	PWMOUT/ DOUT/PVGOUT
C1-P13	DIN	C1-P38	PWMOUT/ DOUT/PVGOUT
C1-P14	DIN/AIN	C1-P39	PWMOUT/ DOUT/PVGOUT
C1-P15	DIN/AIN	C1-P40	PWMOUT/ DOUT/PVGOUT
C1-P16	DIN/AIN	C1-P41	PWMOUT/ DOUT/PVGOUT
C1-P17	DIN/AIN	C1-P42	PWMOUT/ DOUT/PVGOUT
C1-P18	DIN/AIN/FreqIN	C1-P43	PWMOUT/ DOUT/PVGOUT
C1-P19	DIN/AIN/FreqIN	C1-P44	PWMOUT/ DOUT/PVGOUT
C1-P20	CAN1 +	C1-P45	PWMOUT/ DOUT/PVGOUT
C1-P21	CAN1 -	C1-P46	PWMOUT/ DOUT/PVGOUT
C1-P22	AIN/CAN1 shield	C1-P47	Power supply +
C1-P23	DIN/AIN/FreqIN	C1-P48	Power supply +
C1-P24	DIN/AIN/FreqIN	C1-P49	Power supply +
C1-P25	DIN/AIN/FreqIN	C1-P50	Power supply +

Use care when wiring mating connector. Above pinouts are for device pins.

Danfoss can accept no responsibility for possible errors in catalogues, brochures and other printed material. Danfoss reserves the right to alter its products without notice. This also applies to products already on order provided that such alterations can be made without subsequent changes being necessary in specifications already agreed. All trademarks in this material are property of the respective companies. Danfoss and the Danfoss logotype are trademarks of Danfoss A/S. All rights reserved.