

ENGINEERING  
TOMORROW



Service Manual

# Variable Displacement Pumps

## MP1

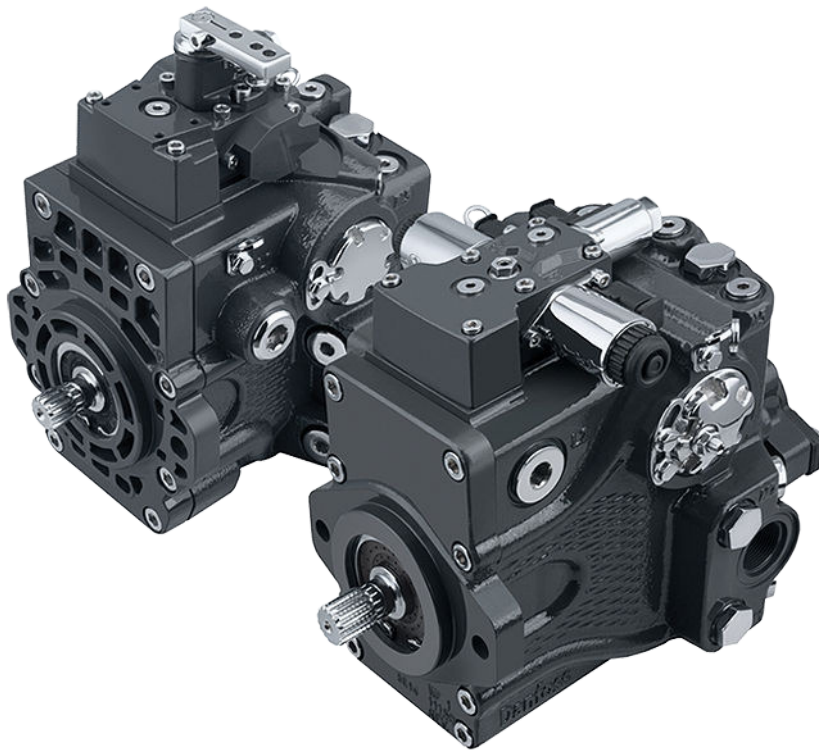

**Revision history**

*Table of revisions*

<b>Date</b>	<b>Changed</b>	<b>Rev</b>
August 2024	Minor corrections to P400738 on MDC Neutral Adjust and G020/G025 on MP1 plug size and torque	0405
January 2024	Minor corrections	0404
December 2021	Added HDC control	0401
October 2021	Added MDC Neutral Adjust, added notes on MP1 Charge Pump Inspection	0306
April 2021	Changed document number from 'AX00000244' to 'AX179786484978' and corrected interface with ECU (EDC) graphic	0305
November 2019	updated minor errors	0203
October 2019	Added automotive controls information	0202
April 2019	Updated for new control types	0201
October 2018	Corred sort strings on MDC and additional options to MDC illustration	0107
January 2018	update control current table	0106
November 2017	Add NFPE	0105
October 2017	Remove HDC	0104
July 2017	update ports and plugs	0103
April 2017	Add HDC	0102
August 2016	First edition	0101

## Contents

### Introduction

Hydrostatics Servicing Overview.....	6
General instructions.....	6
Remove the unit.....	6
Lubricate moving parts.....	6
Replace all O-rings and gaskets.....	6
Safety Precautions.....	7
Unintended machine movement.....	7
Flammable cleaning solvents.....	7
Fluid Under Pressure.....	7
Personal safety.....	7
Symbols used in Danfoss literature.....	8

### Technical specifications

MP1 design specifications.....	9
MP1 technical data.....	9
MP1 operating parameters.....	10
MP1 fluid specifications.....	10

### Operation

High Pressure Relief Valve (HPRV) and charge check.....	11
Bypass function.....	11
Charge Pressure Relief Valve (CPRV).....	12
Loop flushing valve.....	13
Electrical displacement control (EDC).....	14
EDC principle.....	14
EDC operation.....	14
Control signal requirements, EDC MP1.....	15
EDC solenoid data.....	15
Control response.....	16
EDC response time.....	16
Manual override (MOR).....	16
Hydraulic displacement control (HDC).....	18
HDC principle.....	18
HDC operation.....	18
Hydraulic signal pressure range.....	19
Pump output flow direction vs. control pressure.....	19
Control response.....	19
Response time, HDC.....	20
Swashplate angle sensor for EDC controls.....	21
Swash plate angle sensor parameters (EDC).....	21
Swash plate angle sensor connector.....	22
Interface with ECU (EDC).....	22
Manual displacement control (MDC).....	22
MDC principle.....	22
MDC operation.....	24
MDC shaft rotation.....	24
Control response.....	25
MDC response time.....	25
Neutral start switch (NSS).....	25
Case gauge port M14.....	26
Lever.....	27
Forward-neutral-reverse electric control (FNR).....	27
FNR principle.....	27
Control response.....	29
Response time, FNR.....	30
Non feedback proportional electric control (NFPE).....	30
Control signal requirements.....	31
Control response.....	32
Response time.....	32

## Contents

Non-feedback, proportional hydraulic control (NFPH).....	32
Control response.....	33
Response time.....	34
Automotive control (AC).....	34
Control-cut-off valve (CCO valve).....	37
CCO solenoid data.....	38
Brake gauge port with MDC.....	39
Displacement limiter.....	39
Displacement change (approximate).....	39
Speed sensor.....	40
Temperature Range.....	40
Output pulses.....	40
Mating connectors.....	40
Speed sensor 4.5 – 8 V.....	40
Temperature Signal.....	41
<b>Operating parameters</b>	
Input speed.....	42
System Pressure.....	42
Charge pressure.....	43
Charge pump inlet pressure.....	43
Case pressure.....	43
Temperature.....	43
Viscosity.....	44
<b>Fluid and filter maintenance</b>	
Filtration system .....	45
<b>Pressures measurements</b>	
MP1 port locations and gauge installation.....	46
<b>Initial startup procedure</b>	
General .....	48
MP1 start-up procedure.....	48
<b>Troubleshooting</b>	
Overview.....	50
Safety precautions.....	50
Electrical troubleshooting.....	50
System Operating Hot.....	50
Transmission Operates Normally in One Direction Only.....	51
System Does Not Operate in Either Direction.....	51
System noise or vibration.....	52
Neutral Difficult or Impossible to Find.....	52
Sluggish System Response.....	52
<b>Adjustments</b>	
Pump adjustment.....	53
Standard Procedures.....	53
Charge Pressure Relief Valve.....	54
Displacement Limiter.....	55
EDC/HDC Neutral Adjustment.....	56
MDC Neutral Adjust.....	58
Mechanical/Hydraulic Neutral Adjustment.....	59
Servo Adjustment.....	59
Verify neutral setting.....	59
Servo Adjustment Side M4.....	60
<b>Minor repair</b>	
MP1 standard procedures and pump removal.....	61
EDC/HDC Control.....	61
MP1 EDC/HDC control removal.....	61

**Contents**

Controls inspection.....	62
MP1 EDC/HDC control assembly.....	62
MP1 control solenoids/actuator housing replacement.....	64
MDC Control.....	65
MP1 MDC control removal.....	65
MDC Illustration.....	65
MDC Legend.....	66
Controls inspection.....	66
MDC Control Assembly.....	66
Automotive control.....	68
Automotive control removal.....	68
Controls inspection.....	69
Automotive control installation.....	69
Charge Pump.....	71
MP1 charge pump removal.....	71
MP1 charge pump inspection.....	72
MP1 charge pump assembly.....	72
High Pressure Relief Valve (HPRV).....	73
MP1 HPRV valve removal.....	73
HPRV valve inspection.....	73
HPRV Valve Reassembly.....	73
Charge Pressure Relief Valve (CPRV).....	74
MP1 CPRV removal.....	74
CPRV inspection.....	74
MP1 CPRV assembly.....	74
MP1 loop flushing removal (28/32 pictured).....	75
MP1 loop flushing spool inspection.....	76
Reassembly.....	76
Shaft Removal.....	76
Inspection.....	77
Shaft Reassembly.....	77
<b>Fastener size and torque chart</b>	
Fastener size and torque.....	78
MP1 plug size and torque.....	79

## Introduction

### Hydrostatics Servicing Overview

This manual includes information on installation, maintenance, and minor repair of the . It includes a description of the unit and its individual components, troubleshooting information, and minor repair procedures.

Performing minor repairs may require the unit to be removed from the vehicle/machine. Thoroughly clean the unit before beginning maintenance or repair activities. Since dirt and contamination are the greatest enemies of any type of hydraulic equipment, follow cleanliness requirements strictly. This is especially important when changing the system filter and when removing hoses or plumbing.

A worldwide network of Danfoss Global Service Partners is available for major repairs. Danfoss trains and certifies Global Service Partners on a regular basis. You can locate your nearest Global Service Partner using the distributor locator at <http://www.danfoss.com>.

For detailed technical information about the , please see the [relevant technical information document](#).



#### Attention

---

Major repairs requiring the removal of a unit's center section, servo sleeves, or front flange voids the warranty unless a Danfoss Authorized Service Center performs them.

---

## General instructions

### Remove the unit



If necessary, remove the unit from the vehicle/machine. Chock the wheels on the vehicle or lock the mechanism to inhibit movement. Be aware that hydraulic fluid may be under high pressure and/or hot. Inspect the outside of the pump and fittings for damage. Cap hoses after removal to prevent contamination.

### Keep it clean



Cleanliness is a primary means of assuring satisfactory pump life, on either new or repaired units. Clean the outside of the pump thoroughly before disassembly. Take care to avoid contamination of the system ports. Cleaning parts by using a clean solvent wash and air drying is usually adequate.

As with any precision equipment, keep all parts free of foreign materials and chemicals. Protect all exposed sealing surfaces and open cavities from damage and foreign material. If left unattended, cover the pump with a protective layer of plastic.

### Lubricate moving parts



During assembly, coat all moving parts with clean hydraulic fluid. This assures that these parts are lubricated during start-up.

### Replace all O-rings and gaskets



Danfoss recommends that you replace all O-rings, seals and gaskets. Lightly lubricate all O-rings with clean petroleum jelly prior to assembly.

### Secure the unit



## Introduction

For repair, place the unit in a stable position with the shaft pointing downward. It will be necessary to secure the pump while removing and torquing end covers, controls, and valves.

## Safety Precautions

Always consider safety precautions before beginning a service procedure. Protect yourself and others from injury. Take the following general precautions whenever servicing a hydraulic system.

### Unintended machine movement

---

Unintended movement of the machine or mechanism may cause injury to the technician or bystanders. Secure the machine or disable/disconnect the mechanism while servicing to protect against unintended movement.

---

### Flammable cleaning solvents

---

Some cleaning solvents are flammable.  
Do not use cleaning solvents in an area where a source of ignition may be present to avoid possible fire.

---

### Fluid Under Pressure

---

Escaping hydraulic fluid under pressure can have sufficient force to penetrate your skin causing serious injury and/or infection. This fluid may also be hot enough to cause burns.  
Relieve pressure in the system before removing hoses, fittings, gauges, or components. Never use your hand or any other body part to check for leaks in a pressurized line. Use caution when dealing with hydraulic fluid under pressure. Seek medical attention immediately if you are cut by hydraulic fluid.

---

### Personal safety

---

Protect yourself from injury whenever servicing a hydraulic system.  
Use proper safety equipment, including safety glasses, at all times.

---

### Hazardous material

---

Hydraulic fluid contains hazardous material.  
Avoid prolonged contact with hydraulic fluid. Always dispose of used hydraulic fluid according to state, and federal environmental regulations.

---

## Introduction

### Symbols used in Danfoss literature

	WARNING may result in injury		Tip, helpful suggestion
	CAUTION may result in damage to product or property		Lubricate with hydraulic fluid
	Reusable part		Apply grease / petroleum jelly
	Non-reusable part, use a new part		Apply locking compound
	Non-removable item		Inspect for wear or damage
	Option - either part may exist		Clean area or part
	Superseded - parts are not interchangeable		Be careful not to scratch or damage
	Measurement required		Note correct orientation
	Flatness specification		Mark orientation for reinstallation
	Parallelism specification		Torque specification
	External hex head		Press in - press fit
	Internal hex head		Pull out with tool – press fit
	Torx head		Cover splines with installation sleeve
	O-ring boss port		Pressure measurement/gauge location or specification

The symbols above appear in the illustrations and text of this manual. They are intended to communicate helpful information at the point where it is most useful to the reader. In most instances, the appearance of the symbol itself denotes its meaning. The legend above defines each symbol and explains its purpose.



## Technical specifications

### MP1 design specifications

Features	MP1
Design	Axial piston pump with variable displacement using compact servo piston control.
Direction of input rotation	Clockwise or counterclockwise
Recommended installation position	Pump installation position is discretionary, however the recommended control position is on the top or at the side with the top position preferred. If the pump is installed with the control at the bottom, flushing flow must be provided through port M14 located on the EDC, HDC, FNR, NFPE, NFPH, AC-1, AC-2 and MDC control. Vertical input shaft installation is acceptable. The housing must always be filled with hydraulic fluid. Recommended mounting for a multiple pump stack is to arrange the highest power flow towards the input source. Consult Danfoss for non-conformance to these guidelines.
Filtration configuration	Suction or charge pressure filtration

### MP1 technical data

Feature	28	32	38	45
Displacement (cm <sup>3</sup> /rev [in <sup>3</sup> /rev])	28.0 [1.71]	31.8 [1.94]	38.0 [2.32]	45.1 [2.75]
Flow at rated (continuous) speed (l/min [US gal/min])	95.3 [25.2]	108.1 [28.5]	125.3 [33.1]	149.5 [39.5]
Torque at maximum displacement (N·m/bar [lbf·in/1000psi])	0.45 [272.0]	0.51 [308.9]	0.60 [369.1]	0.72 [438.1]
Mass moment of inertia of rotating components (kg·m <sup>2</sup> [slug·ft <sup>2</sup> ])	0.0020 [0.0015]		0.0030 [0.0022]	
Mass (kg [lb])	29.6 [65.3]		38 [83.8]	
Oil volume (liter [US gal])	1.5 [0.40]		2.0 [0.53]	
Mounting flange	ISO 3019-1 flange 101-2 (SAE B)			
Input shaft outer diameter, splines and tapered shafts	ISO 3019-1, outer Ø22mm - 4 (SAE B, 13 teeth) ISO 3019-1, outer Ø25mm - 4 (SAE B-B, 15 teeth)			
	ISO 3019-1, outer Ø22mm - 1 (Straight Key)	ISO 3019-1, outer Ø31mm - 4 (19 teeth) ISO 3019-1, outer Ø25mm - 4 (Straight Key) ISO 3019-1, outer Ø25mm - 3 (Conical keyed, taper 1:8)		
Auxiliary mounting flange with metric fasteners, shaft outer diameter and splines	ISO 3019-1, flange 82-2, outer Ø16mm - 4 (SAE A, 9 teeth) ISO 3019-1, flange 82-2, outer Ø19mm - 4 (SAE A, 11 teeth) ISO 3019-1, flange 101-2, outer Ø22mm - 4 (SAE B, 13 teeth) ISO 3019-1, flange 101-2, outer Ø25mm - 4 (SAE B-B, 15 teeth)			
Main port configuration <b>A, B</b>	ISO 11926-1 - 1 1/16 - 12 (Inch O-ring boss)		ISO 11926-1 - 1 5/16 - 12 (Inch O-ring boss)	
	ISO 6149-1, M27x2 (Metric o-ring boss)		ISO 6162, Ø19mm, (Split flange boss, M10x1.5) ISO 6149-1 - M33x2 (Metric O-ring boss)	
Case drain ports <b>L1, L2</b>	ISO 11926-1, 1 1/16 -12 (Inch O-ring boss) ISO 6149-1, M27x2 (Metric O-ring boss)			
Suction ports <b>S</b>	ISO 11926-1 - 1 1/16-12 (Inch O-ring boss) ISO 6149-1 - M27x2 (Metric O-ring boss)		ISO 11926-1 - 1 5/16-12 (Inch O-ring boss) ISO 6149-1 - M33x2 (Metric O-ring boss)	
Other ports	ISO 11926-1, (Inch O-ring boss) ISO 6149 -1, (Metric O-ring boss)			
Customer interface threads	Metric fasteners			

## Technical specifications

### MP1 operating parameters

Features		Units	28/32	38/45
Input speed	Minimum <sup>1</sup>	min <sup>-1</sup> (rpm)	500	500
	Rated		3400	3300
	Maximum		4000	3900
System pressure	Maximum working pressure	bar [psi]	350 [5000]	350 [5000]
	Maximum pressure		380 [5429]	380 [5429]
	Minimum low loop (above case)		10 [143]	10 [143]
Charge pressure (minimum)		bar [psi]	16 [232]	16 [232]
Charge pump inlet pressure	Minimum (continuous)	bar (absolute) [in Hg vacuum]	0.8 [6]	0.8 [6]
	Minimum (cold start)		0.2 [24]	0.2 [24]
	Maximum		2.0	2.0
Case pressure	Rated	bar [psi]	3 [43]	3 [43]
	Maximum		5 [71]	5 [71]

<sup>1</sup> No load condition. Refer to System Design Parameters/Charge Pump for details.

### MP1 fluid specifications

Features		Units	28/32/38/45
Viscosity	Intermittent <sup>1</sup>	mm <sup>2</sup> /sec. [ SUS]	5 [42]
	Minimum		7 [49]
	Recommended range		12 - 80 [66 - 370]
	Maximum (cold start) <sup>2</sup>		1600 [7500]
Temperature range <sup>3</sup>	Minimum (cold start)	°C [°F]	-40 [-40]
	Recommended range		60 - 85 [140 - 185]
	Maximum continuous		104 [220]
	Maximum intermittent		115 [240]
Filtration (recommended minimum)	Cleanliness per ISO 4406		22/18/13
	Efficiency (charge pressure filtration)	β-ratio	β15-20=75(β10≥10)
	Efficiency (suction filtration)		β35-45=75(β10≥2)
	Recommended inlet screen mesh size	μm	100 - 125

<sup>1</sup> Intermittent=Short term t < 1 min per incident and not exceeding 2 % of duty cycle based load-life.

<sup>2</sup> Cold start = Short term t < 3 min, p < 50 bar [725 psi], n < 1000 min<sup>-1</sup> (rpm)

<sup>3</sup> At the hottest point, normally case drain port.

## Operation

### MP1 high pressure relief valve (HPRV) and charge check

All pumps are equipped with a combination high pressure relief and charge check valve. The high-pressure relief function is a dissipative (with heat generation) pressure control valve for the purpose of limiting excessive system pressures. The charge check function acts to replenish the low-pressure side of the working loop with charge oil. Each side of the transmission loop has a dedicated HPRV valve that is non-adjustable with a factory set pressure. When system pressure exceeds the factory setting of the valve, oil is passed from the high pressure system loop, into the charge gallery, and into the low pressure system loop via the charge check.

The pump order code allows for different pressure settings to be used at each system port. The system pressure order code for pumps with only HPRV is a reflection of the HPRV setting.

HPRV's are factory set at a low flow condition. Any application or operating condition which leads to elevated HPRV flow will cause a pressure rise with flow above a valve setting. Consult factory for application review. Excessive operation of the HPRV will generate heat in the closed loop and may cause damage to the internal components of the pump.

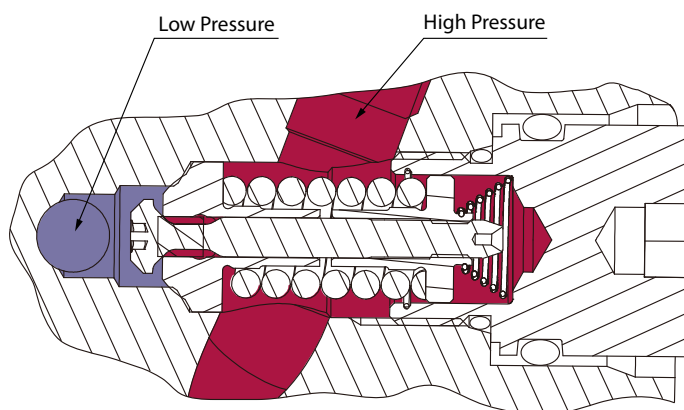

P400353

### Bypass function

The bypass function allows a machine or load to be moved without rotating the pump shaft or prime mover. The single pump HPRV valve also provides a loop bypass function when each of the two HPRV hex plugs are mechanically backed out three full turns.

Engaging the bypass function mechanically connects both A & B sides of the working loop to the common charge gallery.

Possible damage to hydromotor(s).

Excessive speeds and extended load/vehicle movement must be avoided. The load or vehicle should be moved not more than 20% of maximum speed and for a duration not exceeding 3 minutes. When the bypass function is no longer needed, care should be taken to re-seat the HPRV hex plugs to the normal operating position.

## Operation

### MP1 charge pressure relief valve (CPRV) function

An internal charge pressure relief valve (CPRV) regulates charge pressure within the hydraulic circuit. The CPRV is a direct acting poppet valve that regulates charge pressure at a designated level above case pressure.

The charge pressure relief valve setting is specified within the model code of the pump. pumps with charge pump have the CPRV set at 1800 rpm while MP1 pumps without charge pump have the CPRV set with 18.9 l/min [5.0 US gal/min] of external supply flow. The charge pressure rise rate, with flow, is approximately 1 bar/10 liter [5.4 psi/US gal].

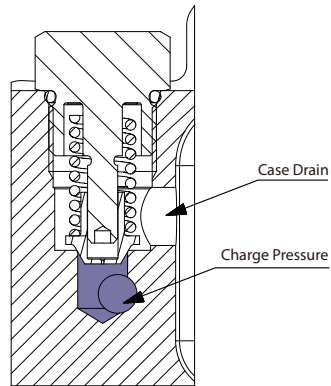

P400341

## Operation

### Loop flushing valve

MP1 pumps are available with an optional integral loop flushing. A loop flushing valve will remove heat and contaminants from the main loop at a rate faster than otherwise possible.

The MP1 loop flushing design is a simple spring centered shuttle spool with an orifice plug. The shuttle shifts at approximately 3.9 bar [55.7 psi]. The flushing flow is a function of the low loop system pressure (charge) and the size of the plug.

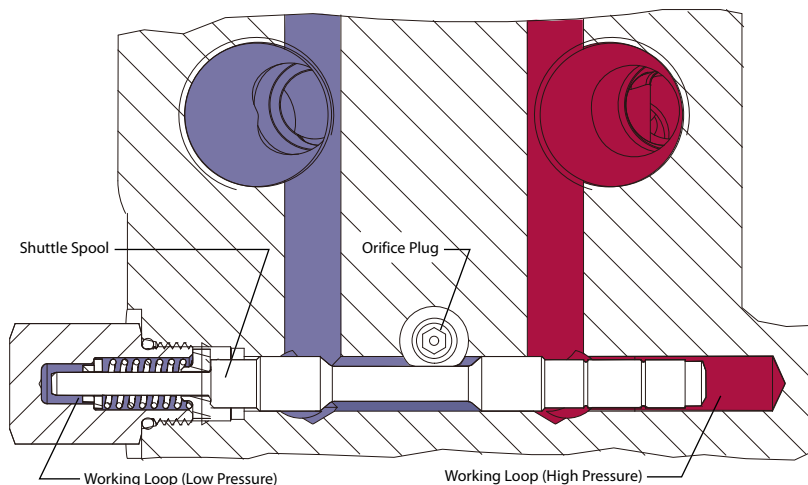

P400342

### Loop flushing performance

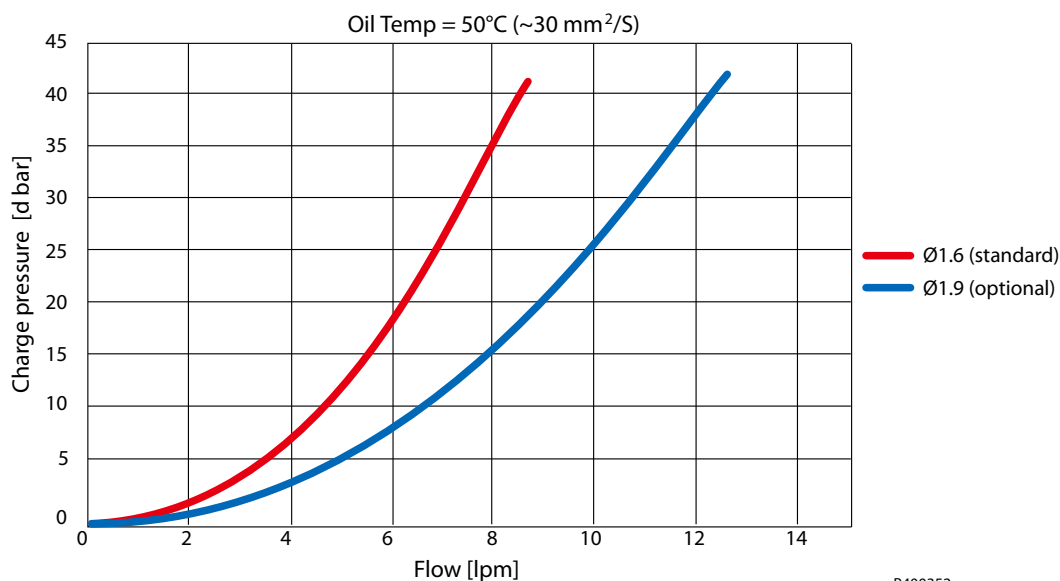

P400352

When a pump is used with an external loop flushing shuttle valve, ensure that the charge setting of the pump matches the setting of the loop flushing shuttle valve. Contact your Danfoss representative for the availability of additional charge relief settings.

## Operation

### Electrical displacement control (EDC)

#### EDC principle

An EDC is a displacement (flow) control. Pump swashplate position is proportional to the input command and therefore vehicle or load speed (excluding influence of efficiency), is dependent only on the prime mover speed or motor displacement.

The Electrical Displacement Control (EDC) consists of a pair of proportional solenoids on each side of a three-position, four-way porting spool. The proportional solenoid applies a force input to the spool, which ports hydraulic pressure to either side of a double acting servo piston. Differential pressure across the servo piston rotates the swashplate, changing the pump's displacement from full displacement in one direction to full displacement in the opposite direction. Under some circumstances, such as contamination, the control spool could stick and cause the pump to stay at some displacement.

A 170  $\mu\text{m}$  screen is located in the supply line immediately before the control porting spool.

#### EDC control

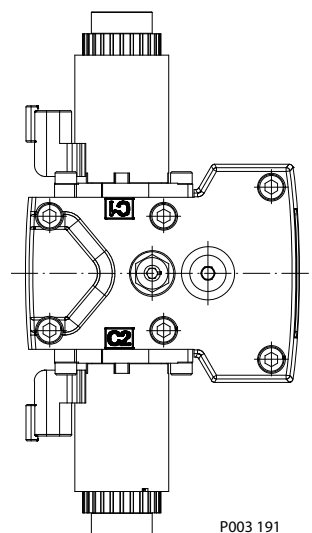

#### EDC schematic

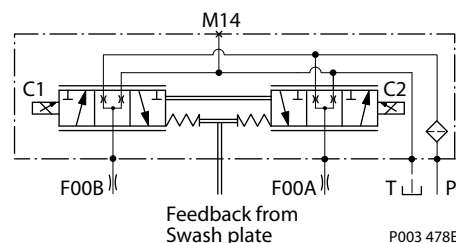

#### EDC operation

EDC's are current driven controls requiring a Pulse Width Modulated (PWM) signal. Pulse width modulation allows more precise control of current to the solenoids. The PWM signal causes the solenoid pin to push against the porting spool, which pressurizes one end of the servo piston, while draining the other. Pressure differential across the servo piston moves the swashplate.

A swashplate feedback link, opposing control links, and a linear spring provide swashplate position force feedback to the solenoid. The control system reaches equilibrium when the position of the swashplate spring feedback force exactly balances the input command solenoid force from the operator. As hydraulic pressures in the operating loop change with load, the control assembly and servo/swashplate system work constantly to maintain the commanded position of the swashplate.

## Operation

The EDC incorporates a positive neutral deadband as a result of the control spool porting, preloads from the servo piston assembly, and the linear control spring. Once the neutral threshold current is reached, the swashplate is positioned directly proportional to the control current. To minimize the effect of the control neutral deadband, we recommend the transmission controller or operator input device incorporate a jump up current to offset a portion of the neutral deadband.

The neutral position of the control spool does provide a positive preload pressure to each end of the servo piston assembly.

When the control input signal is either lost or removed, or if there is a loss of charge pressure, the spring-loaded servo piston will automatically return the pump to the neutral position.

### Control signal requirements, EDC MP1

*Pump displacement vs. control current*

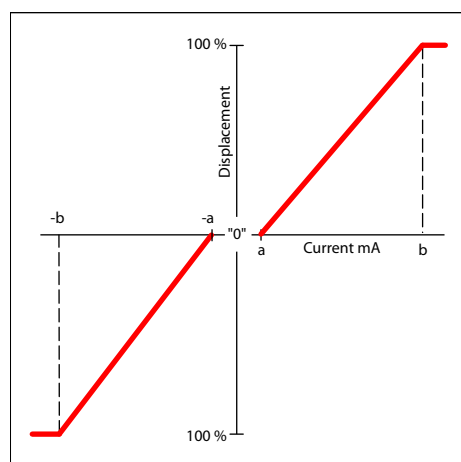

*EDC control current*

Voltage		12 V <sub>DC</sub>	24 V <sub>DC</sub>
Minimum current to stroke pump	a*	640 mA	330 mA
	b	1640 mA	820 mA
Pin connections		any order	

\* Factory test current, for vehicle movement or application actuation expect higher or lower value.

### EDC solenoid data

Description		12 V	24 V
Maximum current		1800 mA	920 mA
Nominal coil resistance	@ 20 °C [68 °F]	3.66 Ω	14.20 Ω
	@ 80 °C [176 °F]	4.52 Ω	17.52 Ω
Inductance		33 mH	140 mH
PWM signal frequency	Range	70 – 200 Hz	
	Recommended*	100 Hz	
IP Rating	IEC 60 529	IP 67	
	DIN 40 050, part 9	IP 69K with mating connector	
Connector color		Black	

\* PWM signal required for optimum control performance.

## Operation

### *Pump output flow direction vs. control signal*

Shaft rotation	CW		CCW	
Coil energized*	C1	C2	C1	C2
Port A	out	in	in	out
Port B	in	out	out	in
Servo port pressurized	M4	M5	M4	M5

\* For coil location see Installation drawings.

### Control response

controls are available with optional control passage orifices to assist in matching the rate of swash-plate response to the application requirements (e.g. in the event of electrical failure).

The time required for the pump output flow to change from zero to full flow (acceleration) or full flow to zero (deceleration) is a net function of spool porting, orifices, and charge pressure.

A swash-plate response times table is available for each frame size. Testing should be conducted to verify the proper orifice selection for the desired response. Typical response times at the following conditions:

- Δ p = 250 bar [3626 psi]
- Charge pressure = 20 bar [290 psi]
- Viscosity and temperature = 30 mm<sup>2</sup>/s [141 SUS] and 50 °C [122 °F]
- Speed = 1800 min<sup>-1</sup> (rpm)

### *MP1 EDC response time*

Stroking direction	0.8 mm [0.03 in] orifice		1.0 mm [0.04 in] orifice		1.3 mm [0.05 in] orifice		No orifice	
	28/32	38/45	28/32	38/45	28/32	38/45	28/32	38/45
Neutral to full flow	1.3 s	2.1 s	0.9 s	1.3 s	0.6 s	0.9 s	0.4 s	0.6 s
Full flow to neutral	1.0 s	1.5 s	0.7 s	0.9 s	0.4 s	0.6 s	0.2 s	0.3 s

### Manual override (MOR)

Electro-hydraulic controls are available with a Manual Over Ride (MOR) either standard or as an option for temporary actuation of the control to aid in diagnostics.

Initial actuation of the o-ring seal MOR plunger will require a force of 45 N. Additional actuations typically require less force to engage the MOR plunger. Proportional control of the pump via the MOR is not intended. The MOR plunger has a 4 mm diameter and must be manually depressed to be engaged. Depressing the plunger mechanically moves the control spool which allows the pump to go on stroke.

**Unintended MOR operation can cause the pump to go into stroke.**

**The vehicle or device must always be in a safe condition (example: vehicle lifted off the ground) when using the MOR function. The MOR should be engaged anticipating a full stroke response from the pump.**

Refer to control flow table for the relationship of solenoid to direction of flow.



**Operation**

*MOR and schematic*

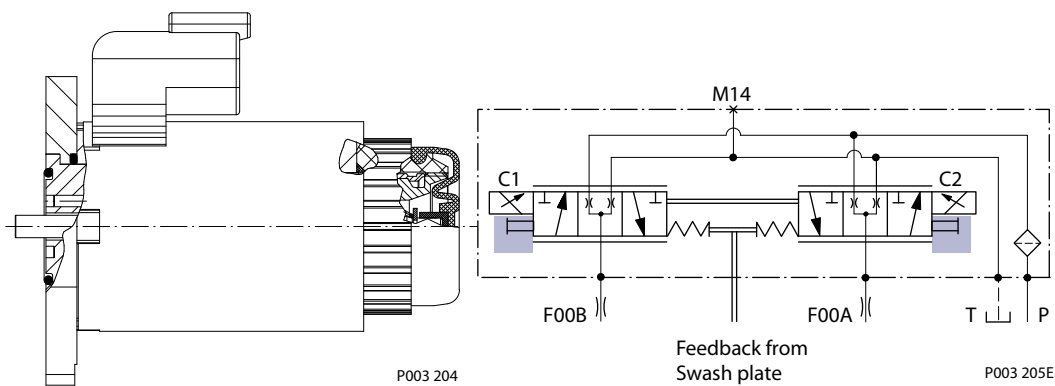

## Operation

### Hydraulic displacement control (HDC)

#### HDC principle

An HDC is a Hydraulic Displacement Control. Pump swashplate position is proportional to the input command and therefore vehicle speed or load speed (excluding influence of efficiency), is dependent only on the prime mover speed or motor displacement.

The HDC control uses a hydraulic input signal to operate a porting spool, which ports hydraulic pressure to either side of a double acting servo piston. The hydraulic signal applies a force input to the spool which ports hydraulic pressure to either side of a double acting servo piston. Differential pressure across the servo piston rotates the swashplate, changing the pump's displacement from full displacement in one direction to full displacement in the opposite direction. Under some circumstances, such as contamination, the porting spool could stick and cause the pump to stay at some displacement.

A serviceable 175 µm screen is located in the supply line immediately before the control porting spool.

#### HDC control

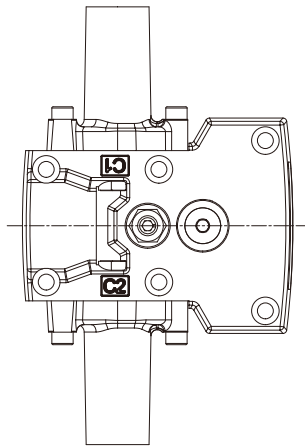

P400520

#### HDC schematic

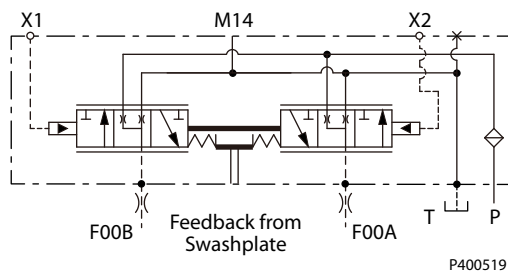

P400519

#### HDC operation

HDC's are hydraulically driven control which ports hydraulic pressure to either side of a porting spool, which pressurizes one end of the servo piston, while draining the other end to case. Pressure differential across the servo piston moves the swashplate.

A swashplate feedback link, opposing control linkage, and a linear spring provide swashplate position force feedback to the hydraulic pressure. As hydraulic pressures in the operating loop change with load, the control assembly and servo/swashplate system work constantly to maintain the commanded position of the swashplate.

## Operation

The HDC incorporates a positive neutral dead band as a result of the control spool porting, preloads from the servo piston assembly, and the linear control spring. Once the neutral threshold point is reached, the swashplate is positioned directly proportional to the control pressure.

When the control input is either lost or removed, or if there is a loss of charge pressure, the spring loaded servo piston will automatically return the pump to the neutral position.

*Pump displacement vs signal pressure*

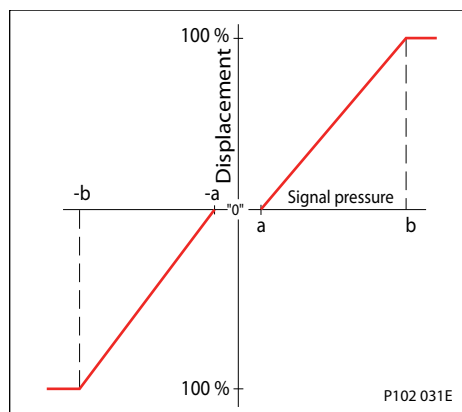

### Hydraulic signal pressure range

Option	Type	a*	b*	Max. pressure
T1	Standard	4.2 bar	16.2 bar	30 bar
T2	Option	3 bar	11.6 bar	30 bar

\* Factory test current, for vehicle movement or application actuation expect a higher or lower value.

### Pump output flow direction vs. control pressure

Shaft rotation HDC	Clockwise (CW) seen from shaft		Counter Clockwise (CCW) seen from shaft	
Port energized	X1	X2	X1	X2
Port A	Out (high)	In (low)	In (low)	Out (high)
Port B	In (low)	Out (high)	Out (high)	In (low)
Servo port high pressure	M4	M5	M4	M5

For appropriate performance of HDC characteristic, keep the drain pressure of pilot valve to be equal or slightly higher than pump case pressure.

### Control response

controls are available with optional control passage orifices to assist in matching the rate of swash-plate response to the application requirements (e.g. in the event of electrical failure).

The time required for the pump output flow to change from zero to full flow (acceleration) or full flow to zero (deceleration) is a net function of spool porting, orifices, and charge pressure.

A swash-plate response times table is available for each frame size. Testing should be conducted to verify the proper orifice selection for the desired response. Typical response times at the following conditions:

$\Delta p = 250 \text{ bar [3626 psi]}$

Charge pressure = 20 bar [290 psi]

Viscosity and temperature = 30 mm<sup>2</sup>/s [141 SUS] and 50 °C [122 °F]

Speed = 1800 min<sup>-1</sup> (rpm)

## Operation

### Response time, HDC

Stroking direction	0.8 mm [0.03 in] orifice		1.0 mm [0.04 in] orifice		1.3 mm [0.05 in] orifice		No orifice	
	28/32	38/45	28/32	38/45	28/32	38/45	28/32	38/45
Neutral to full flow	1.3 s	2.1 s	0.9 s	1.3 s	0.6 s	0.9 s	0.3 s	0.6 s
Full flow to neutral	1.0 s	1.5 s	0.7 s	0.9 s	0.4 s	0.6 s	0.2 s	0.3 s

## Operation

### Swashplate angle sensor for EDC controls

The angle sensor detects the swash plate position with an accuracy dependent upon the calibration effort done for the application and direction of rotation from the neutral position. At minimum the sensor can be used for forward, neutral and reverse (FNR) detection.

The sensor works on the hall-effect technology. The implemented technology is based on a measurement of the magnetic field direction in parallel to the chip surface. This field direction is converted to a voltage signal at the output.

Enhanced calibration of the non-linear behavior leads to more exact calculation of the pump swashplate angle. The 4-pin DEUTSCH connector is part of the sensor housing. The swashplate angle sensor is available for all EDC controls for 12 V and 24 V.

*Swashplate angle vs. output of supply voltage*

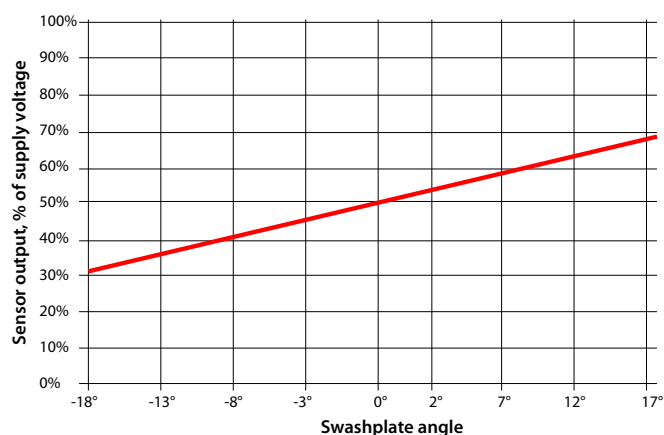

### **Warning**

Strong magnetic fields in the proximity of the sensor can influence the sensor signal and must be avoided.

Contact your Danfoss representative in case the angle sensor will be used for safety functions.

### Swash plate angle sensor parameters (EDC)

Parameter	Minimum	Typical	Maximum
Supply voltage range	4.5 V <sub>DC</sub>	5 V <sub>DC</sub>	5.5 V <sub>DC</sub>
Supply protection	–	–	18 V <sub>DC</sub>
Pump neutral output (% of supply voltage)	–	50%	–
Working range (swash plate angle)	–18°	–	18°
Required supply current	–	–	30 mA
Output current signal	–	9 mA	11 mA
Working temperature	–40 °C	80 °C	115 °C

Electrical Protection	Standard	Class
IP Rating	IEC 60 529	IP 67
	DIN 40 050, part 9	IP 69K with mating connector
EMC Immunity	ISO 11452-2	100 V/m

## Operation

Calibration of the sensor output within the software is mandatory. Vehicle neutral thresholds in the software ( $\pm 0.5^\circ$ ) are vehicle dependent and must consider different conditions, example: system temperature, system pressure and/or shaft speed.

**For safety function:** If the sensor fails (invalid signal  $< 10\%$  or  $> 90\%$  of supply voltage), it must be sure that the ECU will go into a diagnostic mode and shift into limited mode in order for the driver to take the full control or the mechanical breaks should be activated. Strong magnetic fields in the proximity of the sensor can influence the sensor signal and must be avoided.

### Swash plate angle sensor connector

Connector DEUTSCH, 4-pin

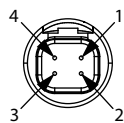

Pin assignment:

1. Ground (GND)
2. Not connected
3. Output signal 1 (SIG 1)
4. Supply (V+)

Connector order numbers

Description	Quantity	Order number
Mating connector DEUTSCH DTM06-4S-E004	1	<b>11105824</b>
Wedge lock WM-4S	1	not available
Socket contact 0462-201-2031	3	
Mating connector kit	1	<b>11212713</b>

### Interface with ECU (EDC)

Interface with ECU diagram

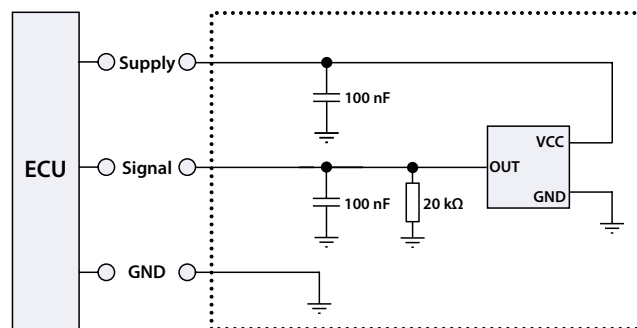

## Manual displacement control (MDC)

### MDC principle

An MDC is a Manual proportional Displacement Control (MDC). The MDC consists of a handle on top of a rotary input shaft. The shaft provides an eccentric connection to a feedback link. This link is connected on its one end with a porting spool. On its other end the link is connected the pumps swashplate.

This design provides a travel feedback without spring. When turning the shaft the spool moves thus providing hydraulic pressure to either side of a double acting servo piston of the pump.

Differential pressure across the servo piston rotates the swash plate, changing the pump's displacement. Simultaneously the swashplate movement is fed back to the control spool providing proportionality between shaft rotation on the control and swashplate rotation.

## Operation

The MDC changes the pump displacement between no flow and full flow into opposite directions. Under some circumstances, such as contamination, the control spool could stick and cause the pump to stay at some displacement.

A 170 µm screen is located in the supply line immediately before the control porting spool.

The MDC is sealed by means of a static O-ring between the actuation system and the control block. Its shaft is sealed by means of a special O-ring which is applied for low friction. The special O-ring is protected from dust, water and aggressive liquids or gases by means of a special lip seal.

### Manual Displacement Control

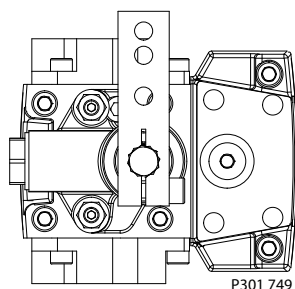

### Pump displacement vs. control lever rotation

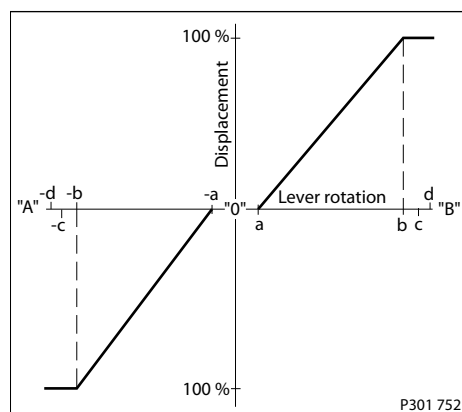

### MDC schematic diagram

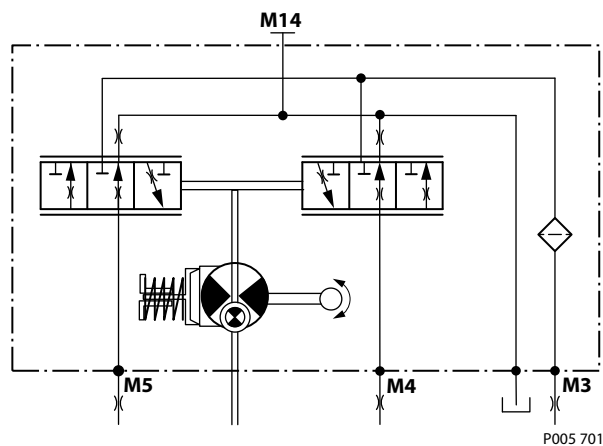

### Where:

Deadband on **B** side -  $a = 3^\circ \pm 1^\circ$

Maximum pump stroke -  $b = 30^\circ +2/-1^\circ$

## Operation

Required customer end stop – **c** = 36° ±3°

Internal end stop – **d** = 40°

### MDC torque

<b>Torque required to move handle to maximum displacement</b>	1.4 N·m [12.39 lbf·in ]
<b>Torque required to hold handle at given displacement</b>	0.6 N·m [5.31 lbf·in]
<b>Maximum allowable input torque</b>	20 N·m [177 lbf·in]

### MDC operation

The MDC provides a mechanical dead-band required to overcome the tolerances in the mechanical actuation. The MDC contains an internal end stop to prevent turning the handle into any inappropriate position.

The MDC provides a permanent restoring moment appropriate for turning the MDC input shaft back to neutral position only. This is required to take the backlash out of the mechanical connections between the Bowden cable and the control.

High case pressure may cause excessive wear and the NSS to indicate that the control is not in neutral position. In addition, if the case pressure exceeds 5 bar there is a risk of an insufficient restoring moment. The MDC is designed for a maximum case pressure of 5 bar and a rated case pressure of 3 bar.

- Customers must install some support to limit the setting range of their Bowden cable to avoid an overload of the MDC.
- Customers can apply their own handle design but they must care about a robust clamping connection between their handle and the control shaft and avoid overload of the shaft.
- Customers can connect two MDC's on a tandem unit in such a way that the actuation force will be transferred from the pilot control to the second control. The kinematic of the linkages must ensure that either control shaft is protected from torque overload.

### ! Caution

Using the internal spring force on the input shaft is not an appropriate way to return the customer connection linkage to neutral, or to force a Bowden cable or a joystick back to neutral position. It is not applicable for any limitation of the Bowden cable stroke, except the applied torque to the shaft will never exceed 20 N·m.

### MDC shaft rotation

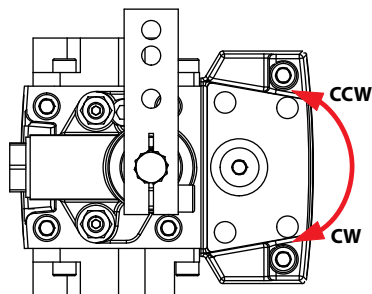

Pump shaft rotation*	Clockwise (CW)		Counter-clockwise (CCW)	
	CW	CCW	CW	CCW
Port A	in (low)	out (high)	out (high)	in (low)
Port B	out (high)	in (low)	in (low)	out (high)
Servo port high pressure	M5	M4	M5	M4

\* As seen from shaft side.



## Operation

### Control response

controls are available with optional control passage orifices to assist in matching the rate of swash-plate response to the application requirements (e.g. in the event of electrical failure).

The time required for the pump output flow to change from zero to full flow (acceleration) or full flow to zero (deceleration) is a net function of spool porting, orifices, and charge pressure.

A swash-plate response times table is available for each frame size. Testing should be conducted to verify the proper orifice selection for the desired response. Typical response times at the following conditions:

$\Delta p = 250 \text{ bar}$  [3626 psi]

Charge pressure = 20 bar [290 psi]

Viscosity and temperature = 30 mm<sup>2</sup>/s [141 SUS] and 50 °C [122 °F]

Speed = 1800 min<sup>-1</sup> (rpm)

### MP1 MDC response time

Code	Orifice description (mm)				Stroking direction (sec)			
	P	A	B	Tank (A +B)	Neutral to full flow		Full flow to neutral	
					28/32	38/45	28/32	38/45
<b>C1</b>	–	0.8	0.8	–	1.3	1.8	0.9	1.2
<b>C2</b>	–	1.3	1.3	–	0.5	0.7	0.4	0.5
<b>C3</b>	–	–	–	–	0.3	0.3	0.3	0.3
<b>C4</b>	–	1.0	1.0	–	0.8	1.1	0.6	0.8
<b>C6</b>	–	–	–	1.0	0.5	1.0	0.5	0.7
<b>C7</b>	–	–	–	1.3	0.4	0.7	0.5	0.5
<b>C8</b>	0.8	–	–	0.6	1.5	2.6	1.4	1.9
<b>C9</b>	1.0	–	–	0.6	1.3	2.4	1.1	1.8
<b>D1</b>	1.0	–	–	0.8	0.9	1.6	0.8	1.1
<b>D2</b>	1.3	–	–	0.8	0.8	1.5	0.7	1.1
<b>D3</b>	1.3	–	–	1.0	0.6	1.1	0.6	0.8
<b>D4</b>	1.3	1.3	1.3	1.0	0.8	1.3	0.7	0.9
<b>D5</b>	0.6	0.8	0.8	0.6	3.2	4.0	2.0	2.9
<b>E2</b>	1.0	0.8	0.8	0.8	2.1	2.9	1.2	1.7

### Neutral start switch (NSS)

The Neutral Start Switch (**NSS**) contains an electrical switch that provides a signal of whether the control is in neutral. The signal in neutral is Normally Closed (**NC**).

**Operation**

*Neutral start switch schematic*

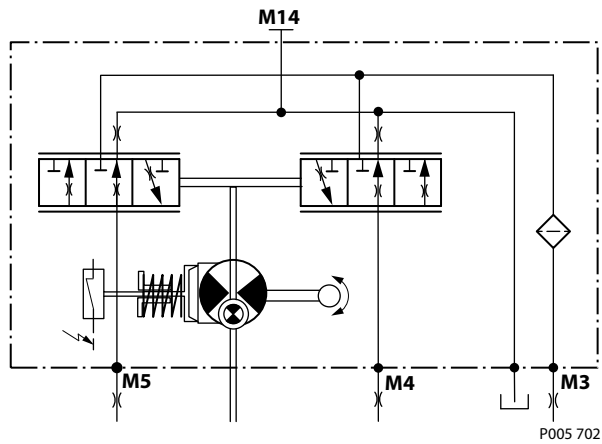

*Neutral start switch data*

<b>Max. continuous current with switching</b>	8.4 A
<b>Max. continuous current without switching</b>	20 A
<b>Max. voltage</b>	36 V <sub>DC</sub>
<b>Electrical protection class</b>	IP67 / IP69K with mating connector

**Case gauge port M14**

The drain port should be used when the control is mounted on the unit's bottom side to flush residual contamination out of the control.

*MDC w/h drain port shown*

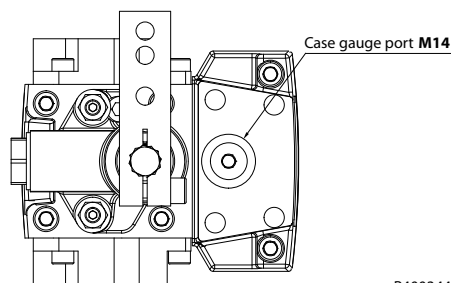

P400344

## Operation

MDC schematic diagram

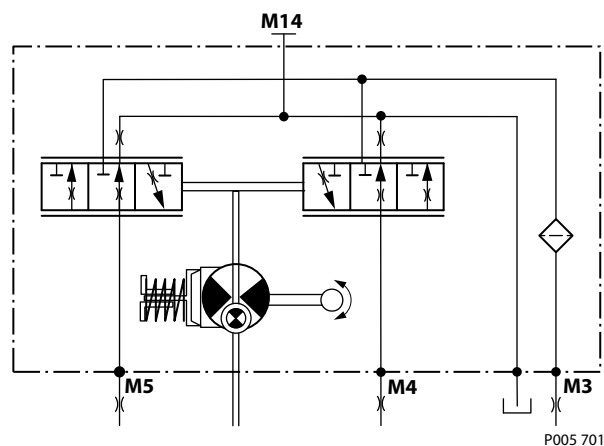

### Lever

MDC controls are available with optional lever/handle. Align with Settings: Y module in the model code.

Standard orientation 90° from input shaft

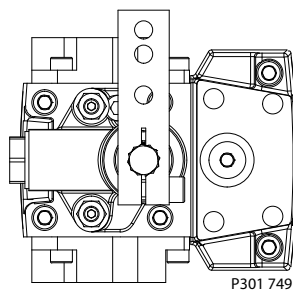

## Forward-neutral-reverse electric control (FNR)

### FNR principle

The 3-position **FNR** control uses an electric input signal to switch the pump to a full stroke position. Under some circumstances, such as contamination, the control spool could stick and cause the pump to stay at some displacement.

A 170 µm screen is located in the supply line immediately before the control porting spool.

Operation

Forward-Neutral-Reverse electric control (FNR)

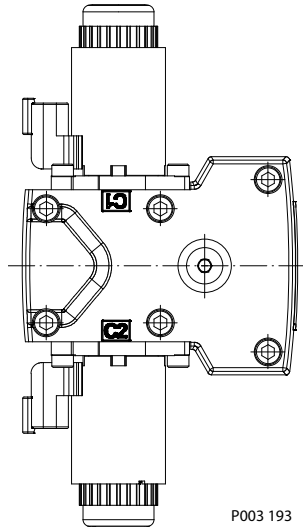

FNR hydraulic schematic

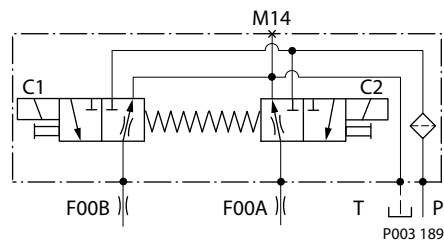

Pump displacement vs. electrical signal

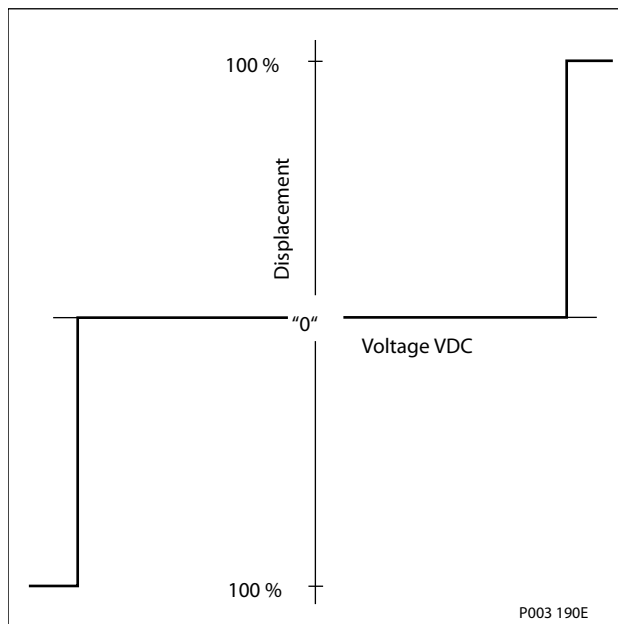

## Operation

### Control current

Voltage	Min. current to stroke pump	Pin connections
12 V	750 mA	any order
24 V	380 mA	

### DEUTSCH connector, 2-pin

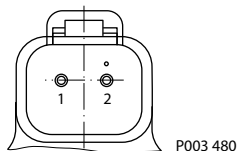

### Connector ordering data

Description	Quantity	Ordering data
Mating connector	1	DEUTSCH DT06-2S
Wedge lock	1	DEUTSCH W2S
Socket contact (16 and 18 AWG)	2	DEUTSCH 0462-201-16141
Danfoss mating connector kit	1	K29657

### Solenoid data

Voltage	12 V	24 V
Minimum supply voltage	9.5 V <sub>DC</sub>	19 V <sub>DC</sub>
Maximum supply voltage (continuous)	14.6 V <sub>DC</sub>	29 V <sub>DC</sub>
Maximum current	1050 mA	500 mA
Nominal coil resistance @ 20 °C [70 °F]	8.4 Ω	34.5 Ω
PWM Range	70-200 Hz	
PWM Frequency (preferred)*	100 Hz	
IP Rating (IEC 60 529) + DIN 40 050, part 9	IP 67 / IP 69K (part 9 with mating connector)	
Bi-directional diode cut off voltage	28 V <sub>DC</sub>	53 V <sub>DC</sub>

\* PWM signal required for optimum control performance.

### Pump output flow direction vs. control signal

Shaft rotation	CW		CCW	
	C1	C2	C1	C2
Coil energized*				
Port A	in	out	out	in
Port B	out	in	in	out
Servo port pressurized	M5	M4	M5	M4

\* For coil location see Installation Drawings.

### Control response

controls are available with optional control passage orifices to assist in matching the rate of swash-plate response to the application requirements (e.g. in the event of electrical failure).

The time required for the pump output flow to change from zero to full flow (acceleration) or full flow to zero (deceleration) is a net function of spool porting, orifices, and charge pressure.

## Operation

A swash-plate response times table is available for each frame size. Testing should be conducted to verify the proper orifice selection for the desired response. Typical response times at the following conditions:

- $\Delta p = 250 \text{ bar [3626 psi]}$
- Charge pressure = 20 bar [290 psi]
- Viscosity and temperature = 30 mm<sup>2</sup>/s [141 SUS] and 50 °C [122 °F]
- Speed = 1800 min<sup>-1</sup> (rpm)

### Response time, FNR

Stroking direction	0.8 mm [0.03 in] orifice		1.0 mm [0.04 in] orifice		1.3 mm [0.05 in] orifice		No orifice	
	28/32	38/45	28/32	38/45	28/32	38/45	28/32	38/45
Neutral to full flow	2.1 s	2.6 s	1.1 s	1.6 s	0.8 s	1.1 s	0.7 s	0.7 s
Full flow to neutral	1.1 s	1.8 s	0.9 s	1.0 s	0.6 s	0.7 s	0.3 s	0.3 s

### Non feedback proportional electric control (NFPE)

The Non Feedback Proportional Electric (NFPE) control is an electrical automotive control in which an electrical input signal activates one of two proportional solenoids that port charge pressure to either side of the pump servo cylinder. The NFPE control has no mechanical feedback mechanism.

A serviceable 170 µm screen is located in the supply line immediately before the control porting spool.

Under some circumstances, such as contamination, the control spool could stick and cause the pump to stay at some displacement.

NFPE control

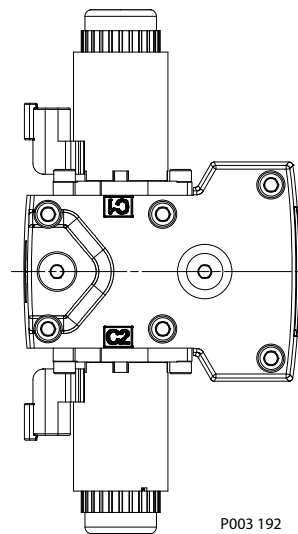

NFPE schematic

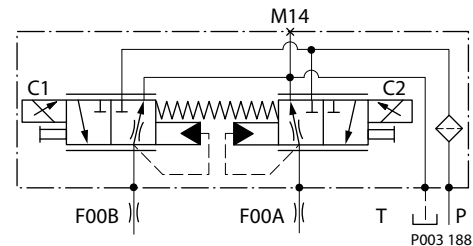

The pump displacement is proportional to the solenoid signal current, but it also depends upon pump input speed and system pressure. This characteristic also provides a power limiting function by reducing the pump swashplate angle as system pressure increases. A typical response characteristic is shown in the accompanying graph. Under some circumstances, such as contamination, the control spool could stick and cause the pump to stay at some displacement.

## Operation

### NFPE pump displacement to input signal

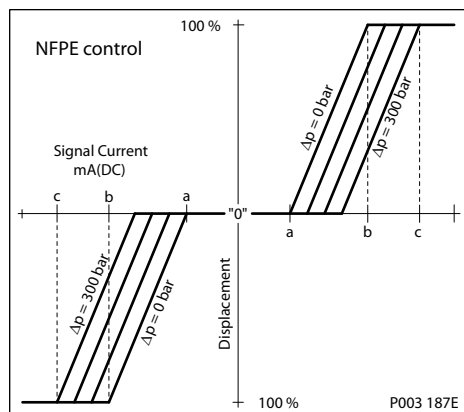

### Control signal requirements

#### Control current

Voltage	a*	b	c	Pin connections
12 V	600 mA	1080 mA	1360 mA	any order
24 V	300 mA	540 mA	680 mA	

\* Factory test current, for vehicle movement or application actuation expect higher or lower value.

#### DEUTSCH connector, 2-pin

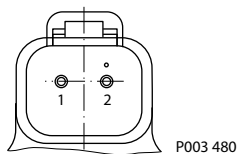

#### Connector ordering data

Description	Quantity	Ordering data
Mating connector	1	DEUTSCH DT06-2S
Wedge lock	1	DEUTSCH W2S
Socket contact (16 and 18 AWG)	2	DEUTSCH 0462-201-16141
Danfoss mating connector kit	1	K29657

Description		12 V	24 V
Maximum current		1800 mA	920 mA
Nominal coil resistance	@ 20 °C [68 °F]	3.66 Ω	14.20 Ω
	@ 80 °C [176 °F]	4.52 Ω	17.52 Ω
Inductance		33 mH	140 mH
PWM signal frequency	Range	70 – 200 Hz	
	Recommended*	100 Hz	
IP Rating	IEC 60 529	IP 67	
	DIN 40 050, part 9	IP 69K with mating connector	
Connector color		Black	

\* PWM signal required for optimum control performance.

## Operation

### *Pump output flow direction vs. control signal*

Shaft rotation	CW		CCW	
Coil energized*	C1	C2	C1	C2
Port A	in	out	out	in
Port B	out	in	in	out
Servo port pressurized	M5	M4	M5	M4

\* For coil location see Installation drawings.

### Control response

MP1 controls are available with optional control passage orifices to assist in matching the rate of swashplate response to the application requirements (e.g. in the event of electrical failure). The time required for the pump output flow to change from zero to full flow (acceleration) or full flow to zero (deceleration) is a net function of spool porting, orifices, and charge pressure. A swashplate response table is available for each frame indicating available swashplate response times. Testing should be conducted to verify the proper orifice selection for the desired response.

*Typical response times at the following conditions:*

<b>Δp</b>	250 bar [3626 psi]
<b>Viscosity and temperature</b>	30 mm <sup>2</sup> /s [141 SUS] and 50°C [122 °F]
<b>Charge pressure</b>	24 bar [348 psi]
<b>Speed</b>	1800 min <sup>-1</sup> (rpm)

### *Response time*

Stroking direction	0.8 mm [0.03] orifice		1.0 mm [0.04] orifice		1.3 mm [0.05] orifice	
	28/32	38/45	28/45	38/45	28/45	38/45
Neutral to full flow	1.5 s	2.2 s	0.9 s	1.4 s	0.6 s	0.8 s
Full flow to neutral	0.9 s	1.1 s	0.6 s	0.7 s	0.4 s	0.5 s

### Non-feedback, proportional hydraulic control (NFPH)

The non-feedback proportional hydraulic (NFPH) control is a hydraulic proportional control in which an input pressure signal directly controls the pump servo piston to achieve pump displacement.

pumps with NFPH control have a special servo cylinder capable of providing proportional control with a hydraulic input.

Swashplate position is proportional to the differential signal pressure at ports X1 and X2, but displacement is also dependent on pump speed and system pressure. This characteristic of non-feedback controls provides a natural power limiting function by reducing the pump swashplate angle as system pressure increases. The accompanying graph shows typical operating characteristics.

The system may require tuning through the pump orifice combinations, control pressure supply line sizing, actuation device output pressure and flow adjustments to achieve proper vehicle performance characteristics.



## Operation

Non-feedback proportional hydraulic control schematic

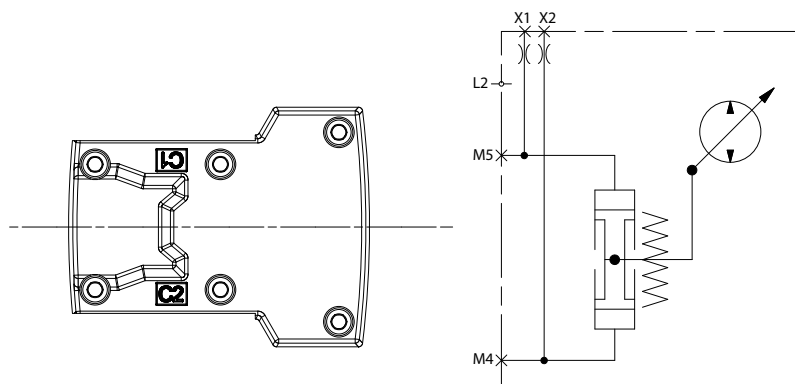

Pump flow direction with NFPH control

Input Shaft Rotation	CW		CCW	
	Port A flow	Out	In	In
Port B flow	In	Out	Out	In
High servo gauge port	M4	M5	M4	M5

NFPH pump displacement to Input signal

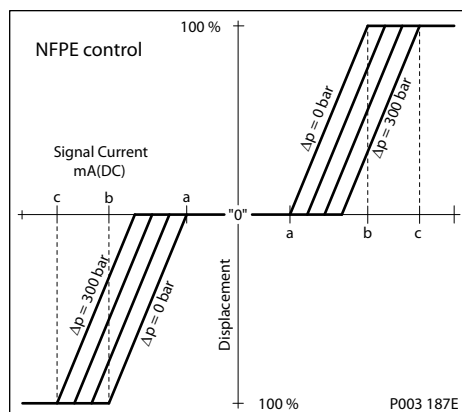

NFPH input signal pressure (bar)

Frame size	a	b	c
28/32	5.5	13.7	17
38/45	5	12.75	16

The values provided in the table above are approximations at 1800 RPM and system delta pressures as indicated in the graph provided. The values are dependent on input speed and delta pressure operating conditions.

### Control response

MP1 controls are available with optional control passage orifices to assist in matching the rate of swashplate response to the application requirements (e.g. in the event of electrical failure). The time required for the pump output flow to change from zero to full flow (acceleration) or full flow to zero (deceleration) is a net function of spool porting, orifices, and charge pressure. A swashplate response

## Operation

table is available for each frame indicating available swashplate response times. Testing should be conducted to verify the proper orifice selection for the desired response.

*Typical response times at the following conditions:*

<b><math>\Delta p</math></b>	250 bar [3626 psi]
<b>Viscosity and temperature</b>	30 mm <sup>2</sup> /s [141 SUS] and 50°C [122 °F]
<b>Charge pressure</b>	24 bar [348 psi]
<b>Speed</b>	1800 min <sup>-1</sup> (rpm)

### Response time

Stroking direction	0.8 mm [0.03] orifice		1.0 mm [0.04] orifice		1.3 mm [0.05] orifice	
	28/32	38/45	28/45	38/45	28/45	38/45
Neutral to full flow	1.5 s	2.2 s	0.9 s	1.4 s	0.6 s	0.8 s
Full flow to neutral	0.9 s	1.1 s	0.6 s	0.7 s	0.4 s	0.5 s

## Automotive control (AC)

The Automotive control (AC) is an electric NFPE control with an integrated micro-controller, installed on the pump.

The integrated micro-controller enhanced control performance with a flexible, configurable control scheme for an entire single path propel transmission. It can be used in combination with fixed and variable displacement hydraulic motors. With the pre-installed application software and easily changeable control parameters, it is possible to tailor the vehicle's driving behavior to the individual requirements of the customer.

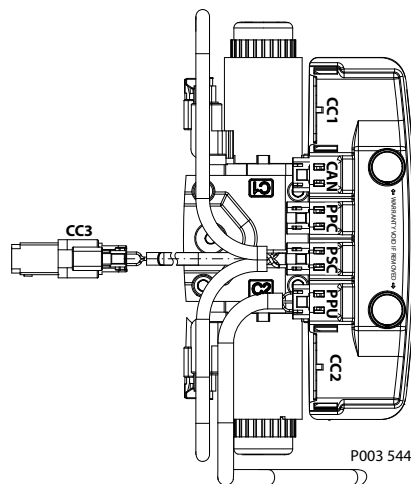

The H1 automotive control is divided into 2 systems:

- AC-1
- AC-2

AC-2 is an extension of AC-1 that features an integrated pump swash plate angle sensor and software enabled functions such as swash plate control.

## Operation

### Mode types

The application software provides 3 different hydrostatic propel methods, defined as mode types, which can be used individually.

<b>Automotive Load dependent</b>	Torque controlled driving behavior. Setpoint for the drive curve is the engine rpm.
<b>Non-Automotive Load independent</b>	Speed controlled driving mode. Setpoint for the drive curve is a joystick or drive pedal signal, independent of the engine rpm. The best performance will be achieved with an AC-2 Swash Plate Sensor.
<b>Creep-Automotive Load dependent</b>	Torque controlled driving behavior (like Automotive). Setpoint for the drive curve is the engine rpm. The setpoint can be reduced by the creep potentiometer if a high engine rpm in combination with low vehicle speed is needed.

### Basic functions

- Four selectable system modes, selectable via switch
- Individual settings for forward and reverse driving direction (4 x 2 curves)
- Independent pump and hydraulic motor profiling and ramping for each mode
- Electric drive pedal connection
- Electronic inching function without separate control valve
- Electric creep mode potentiometer
- Configurable System Mode and Direction change
- Load independent pump displacement control with integrated Swash Plate Angle Sensor (AC-2)
- Hydraulic motor displacement control including brake pressure defeat function

### Performance functions

- ECO fuel saving mode with automatic reduction of the engine speed during transport (Cruise control)
- Vehicle constant speed drive control
- Vehicle speed limitation
- Dynamic brake light, automatic park brake, reverse buzzer and status LED outputs
- Vehicle speed controlled output function
- Temperature compensation for predictable performance
- Advanced CAN J1939 interface for the information exchange with the vehicle control system

### Protection and safety functions

- Safety controlled vehicle start protection with engine speed check, battery check and FNR must be in neutral, etc.
- Operator presence detection
- Hydraulic system overheat and low-temperature protection
- Hydraulic motor over speed protection
- Park brake test mode for roller applications to fulfill SAE J1472/EN500-4
- SIL2 compliant

## Operation

### Engine control and protection

- CAN J1939 engine interface
- Engine speed control via drive pedal with safety controlled monitoring function
- Engine antistall protection
- Engine over speed protection during inching
- Engine speed dependent retarder control
- Engine cold start protection

### Installation features

- Factory calibration for hysteresis compensation
- Starting current adjustment in the factory
- Pre-installed application software and parameter files

---

For more information, see *Integrated Automotive Control (AC) for MP1 and H1P Single Pumps 28-250 Technical Information, BC152986482596*.

---

## Operation

### Control-cut-off valve (CCO valve)

The pump offers an optional control cut off valve integrated into the control. This valve will block charge pressure to the control, allowing the servo springs to de-stroke the pump regardless of the pump's primary control input. There is also a hydraulic logic port, X7, which can be used to control other machine functions, such as spring applied pressure release brakes. The pressure at X7 is controlled by the control cut off solenoid. The X7 port would remain plugged if not needed.

In the normal (de-energized) state of the solenoid charge flow is prevented from reaching the controls. At the same time the control passages and the X7 logic port are connected and drained to the pump case. The pump will remain in neutral, or return to neutral, independent of the control input signal. Return to neutral time will be dependent on oil viscosity, pump speed, swashplate angle, and system pressure.

When the solenoid is energized, charge flow and pressure is allowed to reach the pump control. The X7 logic port will also be connected to charge pressure and flow.

The solenoid control is intended to be independent of the primary pump control making the control cut off an override control feature. It is however recommended that the control logic of the CCO valve be maintained such that the primary pump control signal is also disabled whenever the CCO valve is de-energized. Other control logic conditions may also be considered.

All EDC and MDC controls are available with a CCO valve.

The response time of the unit depends on the control type and the control orifices used.

The CCO-valve is available with 12 V or 24 V solenoid.

### EDC with CCO

#### Control

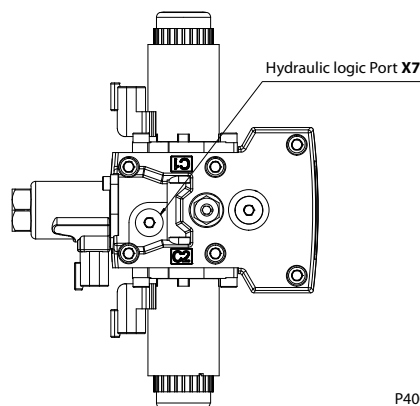

P400346

#### Schematic

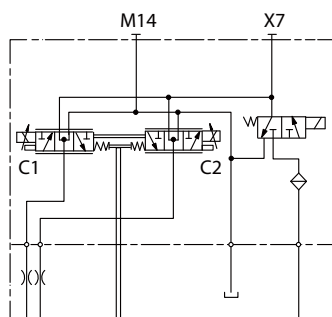

P400349

**Operation**

**MDC with CCO**

Control

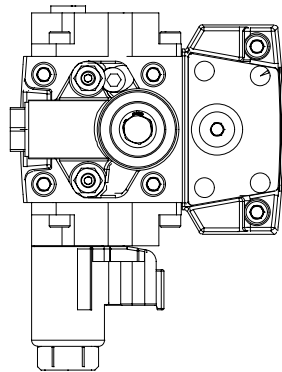

Schematic

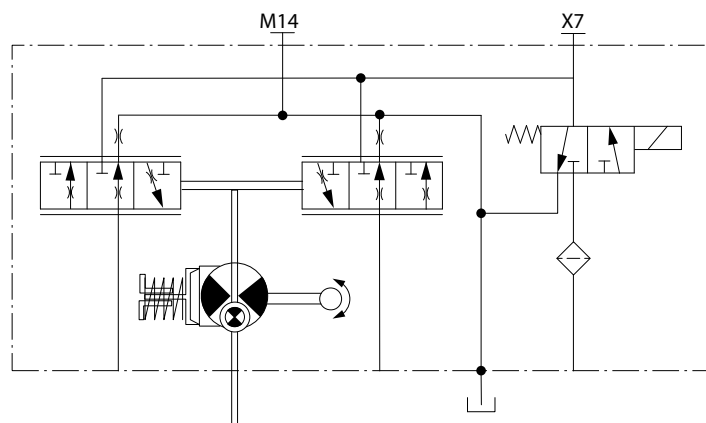

P005 703

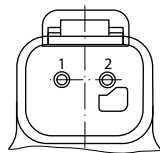

**CCO solenoid data**

Nominal supply voltage		12 V	24 V
Supply voltage	Maximum	14.6 V	29 V
	Minimum	9.5 V	19 V
Bi-directional diode cut off voltage		28 V	53 V
Nominal coil resistance at 20 °C		10.7 Ω	41.7 Ω
Supply current	Maximum	850 mA	430 mA
	Minimum	580 mA	300 mA
PWM frequency	Range	50 – 200 Hz	
	Preferred	100 Hz	
Electrical protection class		IP67 / IP69K with mating connector	

## Operation

CCO solenoids are design for battery voltage application within the voltage range in the table above, in consideration of a wide range of environmental temperature common for known hydraulic applications. Closed loop PWM current supply can be also applied and is helpful in case that the voltage range is exceeded, or ambient temperature could rise in an unusual manner.

### Brake gauge port with MDC

**!** **Caution**

It is not recommended to use brake port for any external flow consumption to avoid malfunction of CCO function.

## Displacement limiter

All pumps are designed with optional mechanical displacement (stroke) limiters factory set to max. displacement.

The maximum displacement of the pump can be set independently for forward and reverse using the two adjustment screws to mechanically limit the travel of the servo piston. Adjustment procedures are found in the Service Manual. Adjustments under operating conditions may cause leakage. The adjustment screw can be completely removed from the threaded bore if backed out to far.

### Displacement limiter

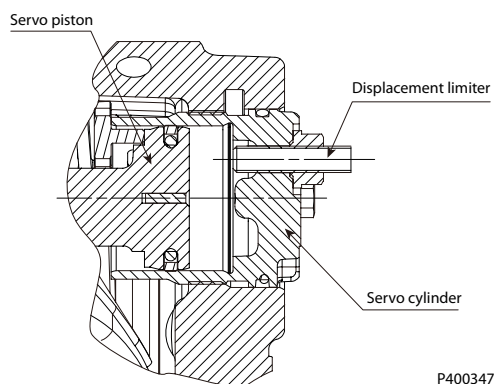

### Displacement change (approximate)

Parameter	28	32	38	45
<b>1 Turn of displacement limiter screw</b>	2.9 cm <sup>3</sup> [0.18 in <sup>3</sup> ]	3.3 cm <sup>3</sup> [0.20 in <sup>3</sup> ]	3.56 cm <sup>3</sup> [0.22 in <sup>3</sup> ]	4.22 cm <sup>3</sup> [0.26 in <sup>3</sup> ]
<b>Internal wrench size</b>	4 mm			
<b>External wrench size</b>	13 mm			
<b>Torque for external hex seal lock nut</b>	23 N·m [204 lbf·in]			

## Operation

### Speed sensor

The speed sensor is designed for rugged outdoor, mobile or heavy industrial speed sensing applications. The detection of the speed is contactless and does not need any calibration or adjustments.

For more information, see *Speed and Temperature Sensor, Technical Information*, **BC152886482203**.

### Temperature Range

Parameter	Minimum	Maximum
Operation temperature range	-40 °C	104 °C

115°C intermittent = short term; t < 1min per incident and not exceeding 2 % of duty cycle based load-life.

### Output pulses

The expected number of output pulses per revolution is shown below.

*The number of output (speed) pulses*

MP1P size	28/32	38/45
Pulses (per rev)	9	11

### Mating connectors

There are available two types of mating connectors Assembly Bag DEUTSCH DTM06-6S, Black and Grey.

Ordering number	
<b>11033865</b>	<b>11033863</b>
Assembly Bag, DEUTSCH DTM06-6S-E004; black, (24-20 AWG) 0.21 -0.52 mm <sup>2</sup>	Assembly Bag, DEUTSCH DTM06-6S, gray, (24-20 AWG) 0.21 -0.52 mm <sup>2</sup>

### Speed sensor 4.5 – 8 V

*Speed sensor connector, 6-pin*

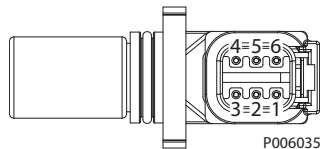

1. Speed signal 2
2. NC
3. Speed signal 1
4. Supply
5. Ground
6. Temperature

### Technical data

Parameter	Min.	Nom.	Max.	Note
<b>Supply voltage</b>	4.5 V <sub>DC</sub>	5 V <sub>DC</sub>	8 V <sub>DC</sub>	Regulated supply voltage. Reverse polarity protected.
<b>Supply protection</b>	–	–	30 V <sub>DC</sub>	Shuts off above 9 V.
<b>Max. required supply current</b>	–	–	25 mA	At supply voltage
<b>Max. output current</b>	–	–	50 mA	
<b>Operation mode</b>	<b>NPN &amp; PNP</b>			Push-Pull amplifier
<b>Temperature signal</b>	-40°C = 2.318V	–	100°C = 0.675V	
<b>Output low</b>	5 %	8.5 %	12 %	Ratiometric output voltage Low state > 0 V to provide wire fault detection



## Operation

Technical data (continued)

Parameter	Min.	Nom.	Max.	Note
Output high	88 %	91.5 %	95 %	
Detectable frequency range	1 Hz	–	10 000 Hz	
Ordering number	149055			
Color of connector	Black			

## Temperature Signal

For calculation of the case fluid temperature and the output signal voltage, see the formulas below:

**$V_0$  – Measured output voltage (V)**

$$V_0 = (-3.88 \cdot 10^{-6} \cdot T^2) + (-1.15 \cdot 10^{-2} \cdot T) + 1.8639$$

**T – Temperature (°C)**

$$T = -1481.96 + \sqrt{2.1962 \cdot 10^6 + \frac{(1.8639 - V_0)}{3.88 \cdot 10^{-6}}}$$

Output signal voltage vs. Temperature

Temperature range							
-55 °C**	-40 °C	-30 °C	0 °C	+30 °C*	+80 °C	+100 °C	+130 °C**
2.485 V	2.318 V	2.205 V	1.864 V	1.515 V	0.919 V	0.675 V	0.303 V

\* Accuracy:  $\pm 1.5$  to  $\pm 4$  °C

\*\* Accuracy:  $\pm 2.5$  to  $\pm 5$  °C

## Response time in fluid

$T_{90}$  definition

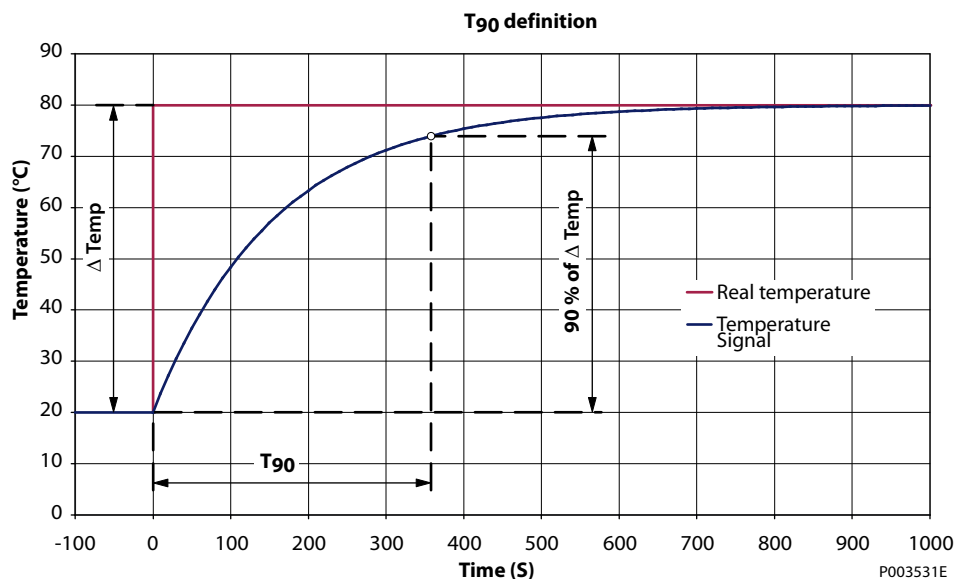

Response time in fluid ( $T_{90}$ ) = 360 s

## Operating parameters

### Input speed

**Minimum speed** is the lowest input speed recommended during engine idle condition. Operating below minimum speed limits pump's ability to maintain adequate flow for lubrication and power transmission.

**Rated speed** is the highest input speed recommended at full power condition. Operating at or below this speed should yield satisfactory product life.

**Maximum speed** is the highest operating speed permitted. Exceeding maximum speed reduces product life and can cause loss of hydrostatic power and braking capacity. Never exceed the maximum speed limit under any operating conditions.

Operating conditions between Rated speed and Maximum speed should be restricted to less than full power and to limited periods of time. For most drive systems, maximum unit speed occurs during downhill braking or negative power conditions.

During hydraulic braking and downhill conditions, the prime mover must be capable of providing sufficient braking torque in order to avoid pump over speed. This is especially important to consider for turbocharged and Tier 4 engines.

#### **Warning**

---

#### **Unintended vehicle or machine movement hazard.**

Exceeding maximum speed may cause a loss of hydrostatic drive line power and braking capacity. You must provide a braking system, redundant to the hydrostatic transmission, sufficient to stop and hold the vehicle or machine in the event of hydrostatic drive power loss.

---

### System Pressure

**System pressure** is the differential pressure between system ports A and B. It is the dominant operating variable affecting hydraulic unit life. High system pressure, which results from high load, reduces expected life. Hydraulic unit life depends on the speed and normal operating, or weighted average, pressure that can only be determined from a duty cycle analysis.

**Application pressure** is the high pressure relief setting normally defined within the order code of the pump. This is the applied system pressure at which the driveline generates the maximum calculated pull or torque in the application.

**Maximum working pressure** is the highest recommended Application pressure. Maximum working pressure is not intended to be a continuous pressure. Propel systems with Application pressures at, or below, this pressure should yield satisfactory unit life given proper component sizing.

**Maximum pressure** is the highest allowable Application pressure under any circumstance. Application pressures above Maximum Working Pressure will only be considered with duty cycle analysis and factory approval. Pressure spikes are normal and must be considered when reviewing maximum working pressure.

---

All pressure limits are differential pressures referenced to low loop (charge) pressure. Subtract low loop pressure from gauge readings to compute the differential.

---

**Minimum low loop pressure** (above case pressure) is the lowest pressure allowed to maintain a safe working condition in the low side of the loop.

## Operating parameters

### Charge pressure

An internal charge relief valve regulates charge pressure. Charge pressure maintains a minimum pressure in the low side of the transmission loop.

The charge pressure setting listed in the order code is the set pressure of the charge relief valve with the pump in neutral, operating at  $1800 \text{ min}^{-1}$  [rpm], and with a fluid viscosity of  $32 \text{ mm}^2/\text{s}$  [150 SUS]. Pumps configured with no charge pump (external charge supply) are set with a charge flow of  $18.9 \text{ l/min}$  [5.0 US gal/min] and a fluid viscosity of  $32 \text{ mm}^2/\text{s}$  [150 SUS].

The charge pressure setting is referenced to case pressure.

### Charge pump inlet pressure

At normal operating temperature charge inlet pressure must not fall below rated charge inlet pressure (vacuum).

Minimum charge inlet pressure is only allowed at cold start conditions. In some applications it is recommended to warm up the fluid (e.g. in the tank) before starting the engine and then run the engine at limited speed until the fluid warms up.

Maximum charge pump inlet pressure may be applied continuously.

### Case pressure

Under normal operating conditions, the rated case pressure must not be exceeded. During cold start case pressure must be kept below **maximum intermittent case pressure**. Size drain plumbing accordingly.

 **Caution**

---

**Possible component damage or leakage**

Operation with case pressure in excess of stated limits may damage seals, gaskets, and/or housings, causing external leakage. Performance may also be affected since charge and system pressure are additive to case pressure.

---

### Temperature

The high temperature limits apply at the hottest point in the transmission, which is normally the motor case drain. The system should generally be run at or below the rated temperature.

The **maximum intermittent temperature** is based on material properties and should never be exceeded.

Cold oil will not affect the durability of the transmission components, but it may affect the ability of oil to flow and transmit power; therefore temperatures should remain  $16 \text{ }^\circ\text{C}$  [ $30 \text{ }^\circ\text{F}$ ] above the pour point of the hydraulic fluid.

The **minimum temperature** relates to the physical properties of component materials. Size heat exchangers to keep the fluid within these limits. Danfoss recommends testing to verify that these temperature limits are not exceeded.

---

Ensure fluid temperature and viscosity limits are concurrently satisfied.

---

## Operating parameters

### Viscosity

**Viscosity** For maximum efficiency and bearing life, ensure the fluid viscosity remains in the recommended range.

The **minimum viscosity** should be encountered only during brief occasions of maximum ambient temperature and severe duty cycle operation.

The **maximum viscosity** should be encountered only at cold start.

## Fluid and filter maintenance

### Filtration system

To prevent premature wear, ensure that only clean fluid enters the hydrostatic transmission circuit. A filter capable of controlling the fluid cleanliness to ISO 4406, class 22/18/13 (SAE J1165) or better, under normal operating conditions, is recommended. These cleanliness levels cannot be applied for hydraulic fluid residing in the component housing/case or any other cavity after transport.

Filtration strategies include suction or pressure filtration. The selection of a filter depends on a number of factors including the contaminant ingress rate, the generation of contaminants in the system, the required fluid cleanliness, and the desired maintenance interval. Filters are selected to meet the above requirements using rating parameters of efficiency and capacity.

Filter efficiency can be measured with a Beta ratio ( $\beta_x$ ). For simple suction-filtered closed circuit transmissions and open circuit transmissions with return line filtration, a filter with a  $\beta$ -ratio within the range of  $\beta_{35-45} = 75$  ( $\beta_{10} \geq 2$ ) or better has been found to be satisfactory. For some open circuit systems, and closed circuits with cylinders being supplied from the same reservoir, a higher filter efficiency is recommended. This also applies to systems with gears or clutches using a common reservoir. For these systems, a charge pressure or return filtration system with a filter  $\beta$ -ratio in the range of  $\beta_{15-20} = 75$  ( $\beta_{10} \geq 10$ ) or better is typically required.

Because each system is unique, only a thorough testing and evaluation program can fully validate the filtration system. Please see *Design Guidelines for Hydraulic Fluid Cleanliness Technical Information, BC152886482150* for more information.

Cleanliness level and $\beta_x$ -ratio <sup>1</sup>			
Filtration (recommended minimum)	Cleanliness per ISO 4406		22/18/13
	Efficiency (charge pressure filtration)	$\beta$ -ratio	$\beta_{15-20} = 75$ ( $\beta_{10} \geq 10$ )
	Efficiency (suction and return line filtration)		$\beta_{35-45} = 75$ ( $\beta_{10} \geq 2$ )
	Recommended inlet screen mesh size	$\mu\text{m}$	100 – 125

<sup>1</sup> Filter  $\beta_x$ -ratio is a measure of filter efficiency defined by ISO 4572. It is defined as the ratio of the number of particles greater than a given diameter ("x" in microns) upstream of the filter to the number of these particles downstream of the filter.

## Pressures measurements

### MP1 port locations and gauge installation

The following table and drawing show the port locations and gauge sizes needed. When testing system pressures, calibrate pressure gauges frequently to ensure accuracy. Use snubbers to protect gauges.

#### Port description

Port	Pressure obtained	Gauge size	Inch/metric	Size port	Wrench size
AM3	Charge pressure	50 bar [1000 psi]	Inch	9/16-18	1/4 inch
			Metric	M14x1.5	6 mm
E/F	Filtration inlet/outlet	-	Inch	9/16-18	1/4 inch
			Metric	M14x1.5	6 mm
L1/L2	Case pressure	10 bar [100 psi]	Inch	1 1/16-12	9/16 inch
			Metric	M27x2	12 mm
MA/MB (28/32)	System A, B pressure	600 bar [10,000 psi]	Inch	9/16-18	11/16 inch
			Metric	M14x1.5	19 mm
MA/MB (38/45)	System A, B pressure	600 bar [10,000 psi]	Inch	3/4-16	7/8 inch
			Metric	M18x1.5	24 mm
M3	Charge pressure	50 bar [1000 psi]	Inch	9/16-18	1/4 inch
			Metric	M14x1.5	6 mm
M4/M5 (28/32)	Servo pressure	50 bar [1000 psi]	Inch	7/16-20	3/16 inch
			Metric	M12x1.5	6 mm
M4/M5 (38/45)	Servo pressure	50 bar [1000 psi]	Inch	9/16-18	1/4 inch
			Metric	M14x1.5	6 mm
M14	Case pressure	10 bar [100 psi]	Inch	7/16-20	1/4 inch
			Metric	M12x1.5	6 mm
S	Charge pump Inlet	-	Inch	1 1/16-12	9/16 inch
			Metric	M27x2	12 mm
X1, X2	Hydraulic control input	-	Inch	9/16-18	1/4 inch
			Metric	M14x1.5	6 mm

## Pressures measurements

### Port locations

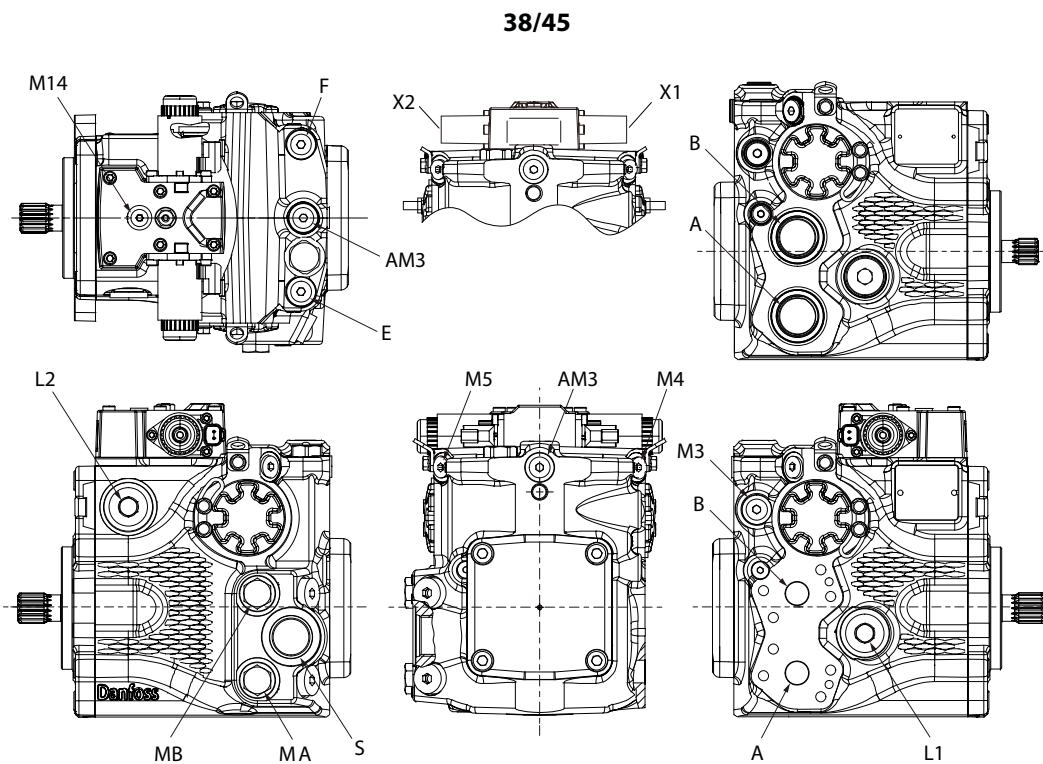
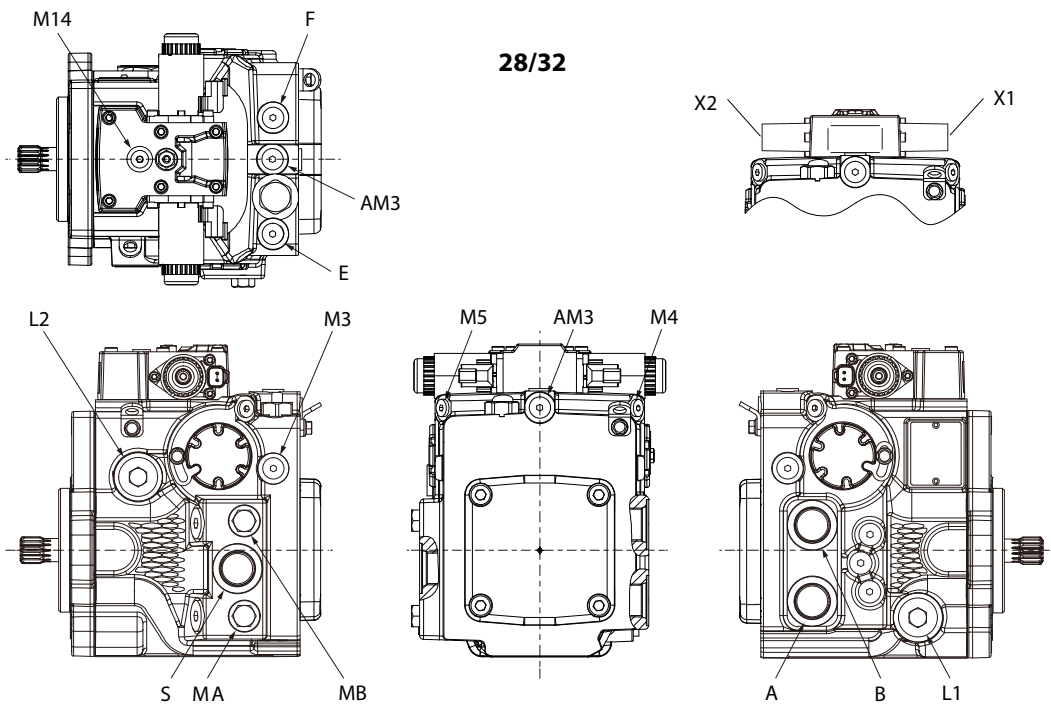

## Initial startup procedure

### General

Follow this procedure when starting-up a new pump installation or when restarting an installation in which the pump has been removed and re-installed on a machine. Ensure pump has been thoroughly tested on a test stand before installing on a machine.

#### **Warning**

Unintended movement of the machine or mechanism may cause injury to the technician or bystanders. To protect against unintended movement, secure the machine or disable/disconnect the mechanism while servicing.

Prior to installing the pump, inspect for damage that may have occurred during shipping.

### MP1 start-up procedure

Follow this procedure when starting-up a new pump installation or when restarting an installation in which the pump has been removed and re-installed on a machine.

Prior to installing the pump on a machine, inspect for damage and ensure pump has been thoroughly tested on a test stand before installing on a machine.

Unintended movement of the machine or mechanism may cause injury to the technician or bystanders. Ensure the machine is secured or disable/disconnect the mechanism while servicing.

1. Ensure that the machine hydraulic oil and system components (reservoir, hoses, valves, fittings, and heat exchanger) are clean and free of any foreign material.
2. Install new system filter element(s) if necessary. Check that inlet line fittings are properly tightened and there are no air leaks.
3. Install the pump. Install a 50 bar [1000 psi] gauge in the charge pressure gauge port M3.
4. Fill the housing by adding filtered oil in the upper case drain port. If the control is installed on top, open M14 plug in the top of the control to assist in air bleed.
5. Fill the reservoir with hydraulic fluid of the recommended type and viscosity. Use a 10-micron filler filter. Fill inlet line from reservoir to pump. Ensure M14 plug in control is closed after filling.
6. Disconnect the pump from all control input signals.
7. Close M14 plug removed in step 4.

#### **Caution**

After start-up the fluid level in the reservoir may drop due to system components filling. Damage to hydraulic components may occur if the fluid supply runs out. Ensure reservoir remains full of fluid during start-up.

Air entrapment in oil under high pressure may damage hydraulic components. Check carefully for inlet line leaks.

Do not run at maximum pressure until system is free of air and fluid has been thoroughly filtered.

8. Use a common method to disable the engine to prevent it from starting. Crank the starter for several seconds. Do not exceed the engine manufacturer's recommendation. Wait 30 seconds and then crank the engine a second time as stated above. This operation helps remove air from the system lines. Refill the reservoir to recommended full oil level.
9. When the gauge begins to register charge pressure, enable and start engine. Let the engine run for a minimum of 30 seconds at low idle to allow the air to work itself out of the system. Check for leaks at all line connections and listen for cavitation. Check for proper fluid level in reservoir.
10. When adequate charge pressure is established (as shown in model code), increase engine speed to normal operating rpm to further purge residual air from the system.



**Initial startup procedure**

- 11.** Shut off engine. Connect pump control signal. Start engine, checking to be certain pump remains in neutral. Run engine at normal operating speed and carefully check for forward and reverse control operation.
- 12.** Continue to cycle between forward and reverse for at least five minutes to bleed all air and flush system contaminants out of loop.

---

Normal charge pressure fluctuation may occur during forward and reverse operation.

---

- 13.** Check that the reservoir is full. Remove charge pressure gauge. The pump is now ready for operation.

## Troubleshooting

### Overview

This section provides general steps to follow if you observe undesirable system conditions. Follow the steps listed until you solve the problem. Some of the items are system specific. We reference the section in this manual of more information is available. Always observe the safety precautions listed in the Introduction section and any precautions related to your specific equipment.

### Safety precautions

**⚠ Caution**

High inlet vacuum causes cavitation which can damage internal pump components.

**⚠ Warning**

Escaping hydraulic fluid under pressure can have sufficient force to penetrate your skin causing serious injury and/or infection. Relieve pressure in the system before removing hoses, fittings, gauges, or components.

**⚠ Warning**

Unintended movement of the machine or mechanism may cause injury to the technician or bystanders. To protect against unintended movement, secure the machine or disable/disconnect the mechanism while servicing.

**⚠ Caution**

Contamination can damage internal components and void the manufacturer's warranty. Take precautions to ensure system cleanliness when removing and reinstalling system lines

**⚠ Warning**

Hydraulic fluid contains hazardous material. Avoid contact with hydraulic fluid. Always dispose of used hydraulic fluid according to state, and federal environmental regulations.

### Electrical troubleshooting

Item	Description	Action
Control operates pump in one direction only	Control coil failure	Measure resistance at coil pins. Resistance should be 14.20 ohms (24V) or 3.66 ohms (12V) at 20°C [70°F]. Replace coil
No pump function	No power to controller	Restore power to controller
Erratic pump function	Electrical connection to pump is bad	Disconnect connection, check wires, reconnect wires

### System Operating Hot

Item	Description	Action
Oil level in reservoir	Insufficient hydraulic fluid will not meet cooling demands of system.	Fill reservoir to proper level.
Heat exchanger	Heat exchanger is not sufficiently cooling the system.	Check air flow and input air temperature for heat exchanger. Clean, repair or replace heat exchanger.
Charge pressure	Low charge pressure will overwork system.	Measure charge pressure. Inspect and adjust or replace charge relief valve. Inspect charge pump. Repair or replace charge pump.

## Troubleshooting

Item	Description	Action
Charge pump inlet vacuum	High inlet vacuum will overwork system. A dirty filter will increase the inlet vacuum. Inadequate line size will restrict flow.	Check charge inlet vacuum. If high, inspect inlet filter and replace as necessary. Check for adequate line size, length or other restrictions.
System relief pressure settings	If the system relief valves are worn, contaminated, or valve settings are too low, the relief valves will be overworked.	Verify settings of high pressure relief valves and replace valves as necessary.
System pressure	Frequent or long term operation over system relief setting will create heat in system.	Measure system pressure. If pressure is too high, reduce loads.

## Transmission Operates Normally in One Direction Only

Item	Description	Action
Open bypass valves	Open bypass causes one or both directions to be inoperative.	Close/repair bypass function.
Input to pump control	Input to control module is operating improperly.	Check control input and repair or replace as necessary.
Control orifices	Control orifice(s) are blocked.	Clean control orifices.
High pressure relief valves (HPRV)	Malfunctioning HPRV can affect one direction while the other functions normally.	Exchange HPRVs. If the problem changes direction, replace the valve that does not operate correctly. Remember to return HPRVs to their original position afterward. Settings may be different for forward/reverse.
Servo pressure	Servo pressure low or decaying.	Check for torn/missing servo seals. Replace and retest. Refer to <b>AX201386485461</b> MP1 Repair Instructions for seal locations. Only a Danfoss Global Service Partner may remove the servo piston without voiding the warranty.

## System Does Not Operate in Either Direction

Item	Description	Action
Oil level in reservoir	Insufficient hydraulic fluid to supply system loop.	Fill reservoir to proper level.
Pump control orifices	Control orifices are blocked.	Clean control orifices.
Open bypass valve	If bypass valves are open, the system loop becomes depressurized.	Close bypass valves. Replace high pressure relief valve if defective.
Charge pressure with pump in neutral	Low charge pressure insufficient to recharge system loop	Measure charge pressure with the pump in neutral. If pressure is low, go to next step.
Pump charge relief valve	A pump charge relief valve that is leaky, or contaminated, or set too low depressurizes the system.	Adjust or replace pump charge relief valve as necessary.
Charge pressure with pump in stroke	Low charge pressure, resulting from elevated loop leakage, is insufficient control pressure to hold pump in stroke.	Isolate pump from motor. With pump in partial stroke and engaged for only a few seconds, check pump charge pressure. Low charge pressure indicates a malfunctioning pump. Good charge pressure indicates a malfunctioning motor or other system component. Check motor charge relief operation (if present).
Charge pump inlet filter	A clogged filter under supplies system loop.	Inspect filter and replace if necessary.
Charge pump	A malfunctioning charge pump provides insufficient charge flow.	Repair or replace the charge pump.
System pressure	Low system pressure does not provide enough power to move load.	Measure system pressure. Continue to next step.
System relief valves	Defective high pressure relief valves cause slow system pressure.	Repair or replace high pressure relief valves.
Input to control	Input is operating improperly.	Repair/replace control.

## Troubleshooting

### System noise or vibration

Item	Description	Action
Reservoir oil level	Low oil level leads to cavitation.	Fill reservoir.
Aeration of the oil/pump inlet vacuum	Air in system decreases efficiency of units and controls. Air in system is indicated by excessive noise in pump, foaming in oil, and hot oil.	Find location where air is entering into the system and repair leak. Check that inlet line is not restricted and is the proper size.
Cold oil	If oil is under cold conditions, it may be too viscous for proper function and pump cavitates.	Allow the oil to warm up to its normal operating temperature with engine at idle speed.
Pump inlet vacuum	High inlet vacuum causes noise/cavitation.	Check that inlet line is not restricted and is the proper size. Check filter and bypass valve.
Shaft couplings	A loose shaft coupling will cause excessive noise.	Replace loose shaft coupling. Replace pump shaft.
Shaft alignment	Misaligned shafts creates noise	Align shafts.
Charge/system relief valves	Unusual noise may indicate sticking valves. Possible contamination.	Clean/replace valves and test pump. May be a normal condition.

### Neutral Difficult or Impossible to Find

Item	Description	Action
Input to pump control	Input to control module is operating improperly.	Disconnect input and check to see if pump comes back to neutral. If Yes, input fault, replace/repair external controller. If No, go to next step.
Pump control neutral	Neutral set improperly.	Shunt servo gauge ports M4 and M5 together with external hose and see if pump comes back to neutral. If Yes: control neutral improperly set. If no: balance the washplate (see <i>Mechanical/hydraulic neutral adjustment</i> ). If you still cannot set neutral, replace the control.

### Sluggish System Response

Item	Description	Action
Oil level in reservoir	Low oil level causes sluggish response.	Fill reservoir.
High pressure relief valves/pressure limiter settings	Incorrect pressure settings affects system reaction time.	Adjust or replace high pressure relief valves.
Low prime mover speed	Low engine speed reduces system performance	Adjust engine speed.
Charge pressure	Incorrect pressure affects system performance	Measure and adjust charge pressure relief or replace charge pump.
Air in system	Air in system produces sluggish system response	Fill tank to proper level. Cycle system slowly for several minutes to remove air from system.
Contaminated control orifices	Control orifices are plugged.	Clean control orifices.
Pump inlet vacuum	Inlet vacuum is too high resulting in reduced system pressure.	Measure charge inlet vacuum. Inspect line for proper sizing. Replace filter. Confirm proper bypass operation.

## Adjustments

### Pump adjustment

This section offers instruction on inspection and adjustment of pump components. Read through the entire topic before beginning a service activity. Refer to Port locations and Gauge installation, for location of gauge ports and suggested gauge size.

### Standard Procedures

 **Caution**

---

Contamination can damage internal components and void your warranty. Take precautions to ensure system cleanliness when removing and reinstalling system lines

---

1. With the prime mover off, thoroughly clean the outside of the pump.
2. If removing the pump, tag each hydraulic line. When you disconnect hydraulic lines, cap them and plug each open port to prevent contamination.
3. Ensure the surrounding area is clean and free of contaminants like dirt and grime.
4. Inspect the system for contamination.
5. Check the hydraulic fluid for signs of contamination: oil discoloration, foam in the oil, sludge, or metal particles.
6. If there are signs of contamination in the hydraulic fluid, replace all filters and drain the hydraulic system. Flush the lines and refill the reservoir with the correct filtered hydraulic fluid.
7. Before re-installing the pump, test for leaks.

## Adjustments

### Charge Pressure Relief Valve

This procedure explains how to check and adjust the charge pressure relief valve. Refer to model code located on serial number plate for charge relief setting.

1. Install a 50 bar [1000 psi] pressure gauge in charge pressure gauge port M3. Install a 10 bar [100 psi] gauge at case pressure port L1, L2. Operate the system with the pump in neutral (zero displacement) when measuring charge pressure.

Listed pressures assume a pump speed of 1800 min<sup>-1</sup> (rpm) and charge flow of 26.5 l/min [7 US gal/min]. At higher pump speeds or higher charge flows the charge pressure will rise over the rated setting.

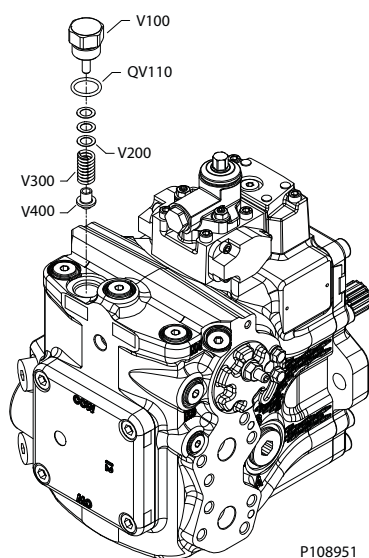

2. Add or remove shims (V200) until the desired setting is achieved.
3. Remove the gauges and plug the open ports.

## Adjustments

### Displacement Limiter

If your pump has displacement limiters, you will find them on either servo cover. You can limit forward and reverse displacement independently.

**!** **Caution**

Before adjusting the displacement limiter, mark the position of the servo cylinder. Be sure the servo cylinder does not turn when setting the displacement limiter locknut.

1. Loosen the lockingnut.
2. Rotate the adjusting screw to achieve the desired displacement.
3. After establishing the desired maximum displacement setting, hold the adjusting screw while torquing the locknut to the value shown.

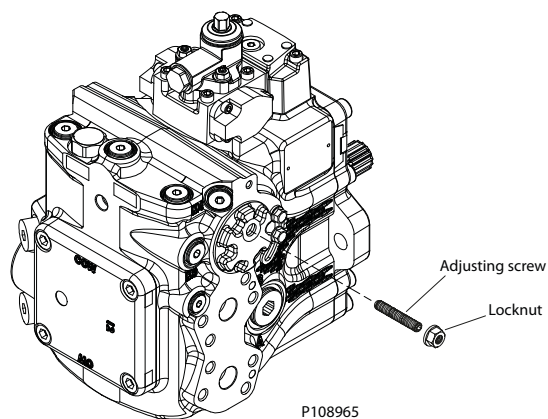

*Displacement limiter adjustment data*

Displacement	Locknut wrench size and torque	Adjusting screw wrench size	Approximate displacement change per revolution of adjusting screw
28	13 mm 23 N·m [17 lbf·ft]	4 mm	2.9 cm <sup>3</sup> [0.18 in <sup>3</sup> ]
32	13 mm 23 N·m [17 lbf·ft]	4 mm	3.3 cm <sup>3</sup> [0.20 in <sup>3</sup> ]
38	13 mm 23 N·m [17 lbf·ft]	4 mm	3.56 cm <sup>3</sup> [0.22 in <sup>3</sup> ]
45	13 mm 23 N·m [17 lbf·ft]	4 mm	4.22 cm <sup>3</sup> [0.26 in <sup>3</sup> ]

## Adjustments

### EDC/HDC Neutral Adjustment

All functions of the control are preset at the factory. Adjust the pump to neutral with the pump running on a test stand or on the vehicle/machine with the prime mover operating. If adjustment fails to give satisfactory results, you may need to replace the control or coils. See Minor repair for details.

#### Warning

Unintended movement of the machine or mechanism may cause injury to the technician or bystanders. To protect against unintended movement, secure the machine or disable/disconnect the mechanism while servicing.

1. Install a 50 bar [1000 psi] gauge in each of the two servo gauge ports (M4 and M5). Disconnect the external control input (electrical/hydraulic connections) from the control. Start the prime mover and operate at normal speed.
2. Use a 4mm internal hex wrench to hold the neutral adjusting screw stationary while loosening the locknut with a 13mm wrench.
3. Observe pressure gauges. If necessary, turn adjusting screw to reduce any pressure differential.

A small pressure differential of 1.5 bar [22 psi] or less is acceptable. Achieving zero differential is usually not possible.

Adjustment of the EDC/HDC is very sensitive. Be sure to hold the hex wrench steady while loosening the locknut. Total adjustment is less than 120 degrees.

Control adjustment (EDC shown)

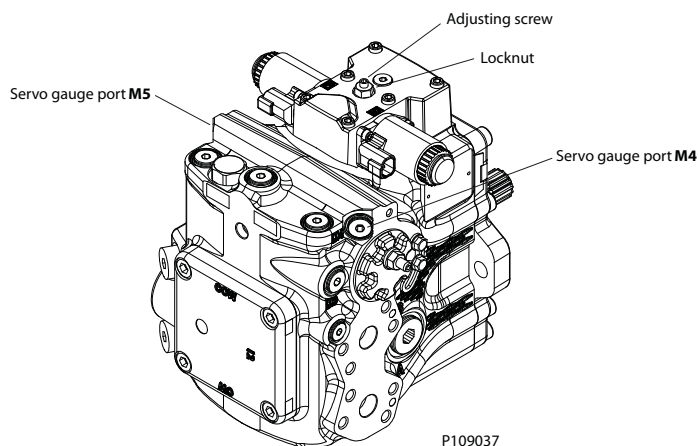

4. Rotate the neutral adjusting screw clockwise until the pressure increases on the gauge. Note the angular position of the wrench. Then rotate the neutral adjusting screw counter clockwise until the pressure increases by an equal amount on the other gauge. Again note the angular position of the wrench.

The illustration shows how the cam on the adjusting pin rotates to adjust for neutral position after the pump is re-installed.



## Adjustments

Neutral adjustment (EDC/HDC bottom view)

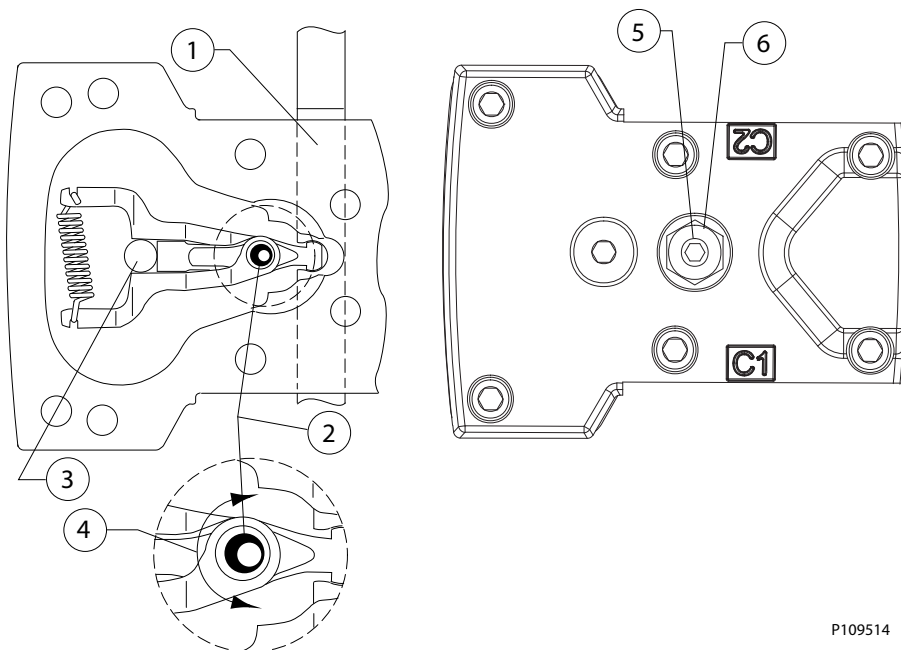

P109514

1. Control spool
  2. Adjusting screw (cam)
  3. Feedback pin
  4. Maximum adjustment less than 120 deg.
  5. Adjusting screw
  6. Lock nut
5. Rotate the neutral adjusting screw clockwise half the distance between the wrench positions noted above. The gauges should read the same pressure, indicating that the control is in its neutral position.
  6. Hold the neutral adjusting screw stationary and tighten the lock nut. Torque to 10 Nm [7 lbf·ft]. Do not over torque the nut.
  7. When the neutral position is set, stop the prime mover, remove the gauges, and install the gauge port plugs. Reconnect the external control input.

*A small pressure differential of 1.5 bar [22 psi] or less is acceptable. Achieving zero differential is usually not possible.*

## Adjustments

### MDC Neutral Adjust

1. Install a 50 bar [1000 psi] pressure gauge in each of the two servo gauge ports (M4 and M5). Remove all mechanical control input. Start the prime mover and operate at normal speed.
2. Reduce the torque of the locking nuts by rotating the nuts by 45 degrees with a 10 mm wrench.
3. If necessary, turn adjusting screw to reduce any existing pressure differential.
4. Rotate the neutral adjusting screw with a 5 mm internal hex bit clockwise until the pressure increases in one of the pressure gauges. Note the angular position of the wrench. Then rotate the neutral adjusting screw counterclockwise until the pressure increases by an equal amount on the other gauge. Again note the angular position of the wrench.
5. Rotate the neutral adjusting screw clockwise half the distance between the wrench position noted above. The gauges should read the same pressure, indicating that the control is in its neutral position.
6. Hold the neutral adjusting screw stationary. Torque lock nuts to 8 N·m [5.9 lbf·ft]. Do not overtorque the nut.
7. When the neutral position is set, stop the prime mover, remove the gauges, and install the gauge port plugs. Reconnect the external control input.

A small pressure differential of 1.5 bar [22 psi] or less is acceptable. Achieving zero differential is usually not possible.

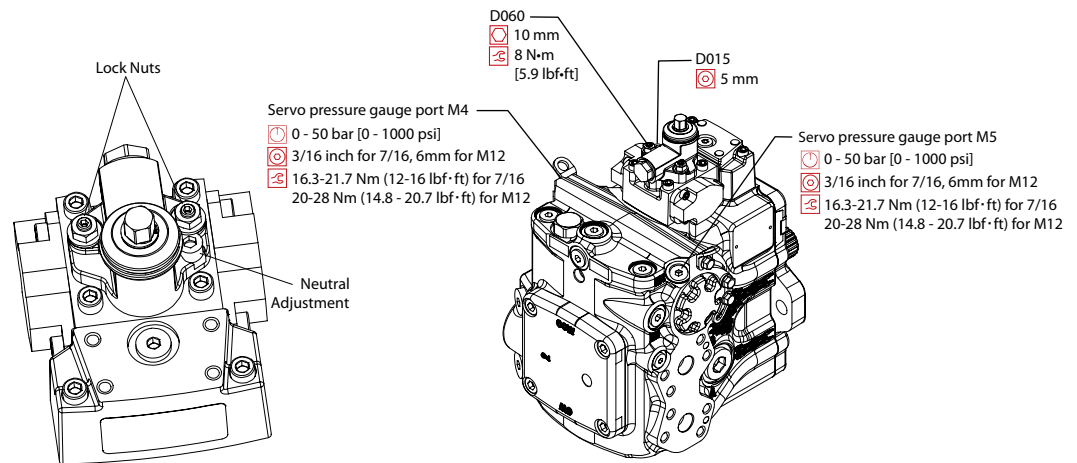

P400738

## Adjustments

### Mechanical/Hydraulic Neutral Adjustment

#### Servo Adjustment

1. Run prime mover at 1800 min<sup>-1</sup>(rpm).
2. If using a PWM signal, ensure the signal is off. Check the servo pressure gauges. Ensure the differential between M4 and M5 is less than 1.5 bar [22 psi].
3. Unthread both servo cylinders 2-3 turns using servo can tool (Tool ID DLD-6247). This step ensures the servo cylinders have no contact with the servo piston.
4. Stroke the pump by turning the adjusting screw (or supplying current to solenoid C1) until the servo pressure at port M4 is 1 to 2 bar [14– 29 psi] greater than at port M5 and the system pressure gauges indicate displacement. Pressure should be greater at port MA for clockwise rotation, or MB for counter clockwise rotation. This also indicates the servo piston is in contact with the servo cylinder on side M5.

A small pressure differential of 1.5 bar [22 psi] or less is acceptable. Achieving zero differential is usually not possible.

5. Slowly thread the servo cylinder on the M5 side in until the system pressure differential starts to decrease. Maintain servo pressure differential between 1-2 bar [14-29 psi] during this step. Continue turning the servo cylinder in until the system pressure differential (between ports MA/MB) is less than 1.5 bar [22 psi]. This procedure sets the servo and swashplate to mechanical neutral on the M5 side.
6. To complete setting neutral, repeat steps 1-5 but stroke the pump in the opposite direction by turning the adjusting screw in the opposite direction, or by supplying current/hydraulic pressure to solenoid C2. Reverse gauge locations (M4 for M5, MB for MA) from those stated above since the pump is now stroking the other direction.
7. Remove all gauges and replace gauge port plugs.

#### *Servo adjustment*

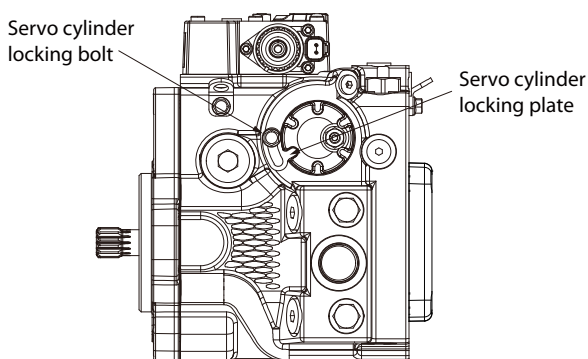

P108967

#### Verify neutral setting

1. If using a PWM signal to set mechanical neutral, check that servo pressure differential is less than 1.5 bar [22 psi].
2. To verify mechanical neutral, provide current to solenoid C1, or turn neutral adjusting screw, until the servo pressure differential is 3 bar [43 psi]. The system pressure differential must be below 1.5 bar [22 psi]. Repeat test on solenoid C2 side.
3. The current required to set the servo pressure differential to 3 bar [43 psi] should be the same for each solenoid.
4. If using neutral adjusting screw to set mechanical neutral, reset control neutral.

## Adjustments

### Servo Adjustment Side M4

1. Run prime mover at 1800 rpm.
2. If using a PWM signal to set mechanical neutral, start with the electronic control testing tool off (no current/hydraulic pressure to either solenoid). Check to be sure the servo pressure differential is less than 1.5 bar [22 psi]. Reference Danfoss testing specifications TS-422 or *Control Neutral Adjustment* instructions.
3. Turn neutral adjusting screw (or supply current/hydraulic pressure to solenoid C2) until the servo pressure at port M5 is less than 1.5 bar [22 psi] greater than at port M4.
4. The system pressure differential must be greater than zero and the pressure at port A (B for clockwise rotation) must be greater than the pressure at port B (A for clockwise rotation). This step ensures the servo is in contact with the servo cylinder on side M4.
5. Slowly turn in the servo cylinder on the M4 side until the system pressure differential starts to decrease. The servo pressure differential must be less than 1.5 bar [22 psi] during this step. Continue turning in the servo cylinder until the system pressure differential is less than 1.5 bar [22 psi]. This procedure sets the servo and swashplate to mechanical neutral.

## Minor repair

### MP1 standard procedures and pump removal

Before working on the pump, thoroughly clean the outside. If the pump has an auxiliary pump attached, remove both pumps as a single unit. Tag and cap all hydraulic lines as they are disconnected, and plug all open ports to ensure that dirt and contamination do not get into the system.

---

Contamination can damage internal components and void the manufacturer's warranty.

Take precautions to ensure system cleanliness when removing and installing system lines.

---

1. With the prime mover off, thoroughly clean all dirt and grime from the outside of the pump.
2. Tag, disconnect, and cap each hydraulic line connected to the pump. As hydraulic lines are disconnected, plug each open port, to ensure that dirt and contamination do not get into the pump.
3. Remove the pump and its auxiliary pump (if applicable) as a single unit.

---

Be careful, do not damage solenoids and electrical connections when using straps or chains to support the pump.

---

4. Ensure the work surface and surrounding area are clean and free of contaminants such as dirt and grime.
5. Inspect the system for contamination.
6. Look at the hydraulic fluid for signs of system contamination, oil discoloration, foam in the oil, sludge, or metal particles.
7. Before replacing the pump, replace all filters and drain the hydraulic system. Flush the system lines and fill the reservoir with the correct, filtered hydraulic fluid.
8. Fill the pump with clean, filtered hydraulic fluid.
9. Attach the pump to the prime mover. Torque mounting screws according to the manufacturers recommendation.
10. Replace all hydraulic lines. Ensure the charge inlet line is filled with fluid.

## EDC/HDC Control

### MP1 EDC/HDC control removal

Follow the instructions for safe removal of the EDC/HDC control.

1. Using a 5 mm internal hex wrench, remove the six cap screws (D250).
2. Remove the control module and gasket (D150). Discard the gasket.
3. If necessary, remove orifices (F00A and F00B) using a 3 mm internal hex wrench. Tag and number them for re-installation.

---

If dowel pins (D300) are removed, ensure they are replaced before re-installing the control.

---

Minor repair

**MP1 EDC/HDC control identification**

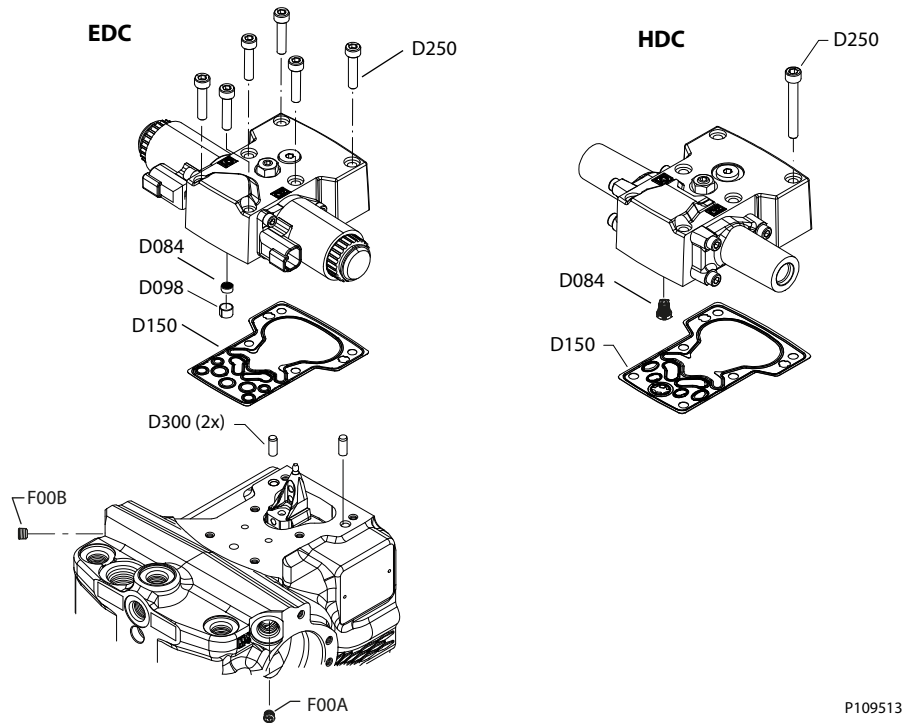

Item	Description	Wrench size	Torque
D150	Control gasket	-	-
D300	Dowel pins	-	-
D250	Cap screw	5 mm internal hex	13 Nm [9.8 lbf·ft]
F00B	Servo orifice	3 mm internal hex	7.9 Nm [5.8 lbf·ft]
F00A	Servo orifice	3 mm internal hex	7.9 Nm [5.8 lbf·ft]

**Controls inspection**

Inspect the machined surfaces on the control pump housing. Inspect plastic PC board housing and its sealing areas. If any damage is found, replace the damaged components.

Controls are available as a complete unit. Do not disassemble the control.

**MP1 EDC/HDC control assembly**

Ensure you install dowel pins (D300) in the housing before installing the control.

1. Install a new gasket (D150).
2. Install dowel pins (D300) in the housing.

**⚠ Warning**

If the feedback pin comes off during operation, the pump will lose control and cause a potentially hazardous situation. Ensure feedback pin is properly torqued before continuing with reassembly.

3. **EDC only** -If the screen (D084) was removed, install a new one. Install it with the mesh facing outward. Install retaining ring (D098).

**Minor repair**

- 4. HDC only** - If the screen (D084) was removed, install a new one. Install it with the mesh facing inward.

*Screen orientations for EDC and HDC*

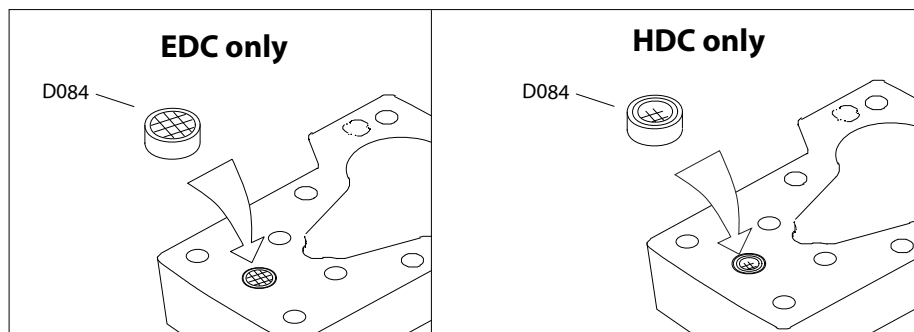

- 5.** Install the control module and six cap screws (D250).

*Torque sequence*

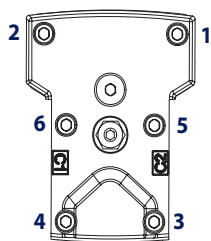

- 6.** Using a 5 mm internal hex wrench, torque the cap screws (D250) to 13.3 Nm [9.8 lbf ft].

## Minor repair

### MP1 control solenoids/actuator housing replacement

1. Disconnect electrical/hydraulic connection and remove the three cap screws (D050) using a 4 mm internal hex wrench.
2. Remove the solenoid/actuator housing (D025/QD77) and O-ring (D025A/QD26). Discard the O-ring.  
Individual coils may be replaced. Use a 12 point 26 mm socket. Torque the coil nut to 5 N·m [3.7 lbf·ft].
3. Inspect the machined surface on the control. If you find any nicks or scratches, replace the component.
4. Lubricate new O-ring (D025A/QD26) using petroleum jelly and install.
5. Install solenoid/actuator housing with three cap screws (D050) using a 4 mm internal hex wrench. Torque screws to 5 N·m [4 lbf·ft].
6. Reconnect electrical/hydraulic connections and test the pump for proper operation.

### MP1 control solenoid identification

#### Control solenoid removal

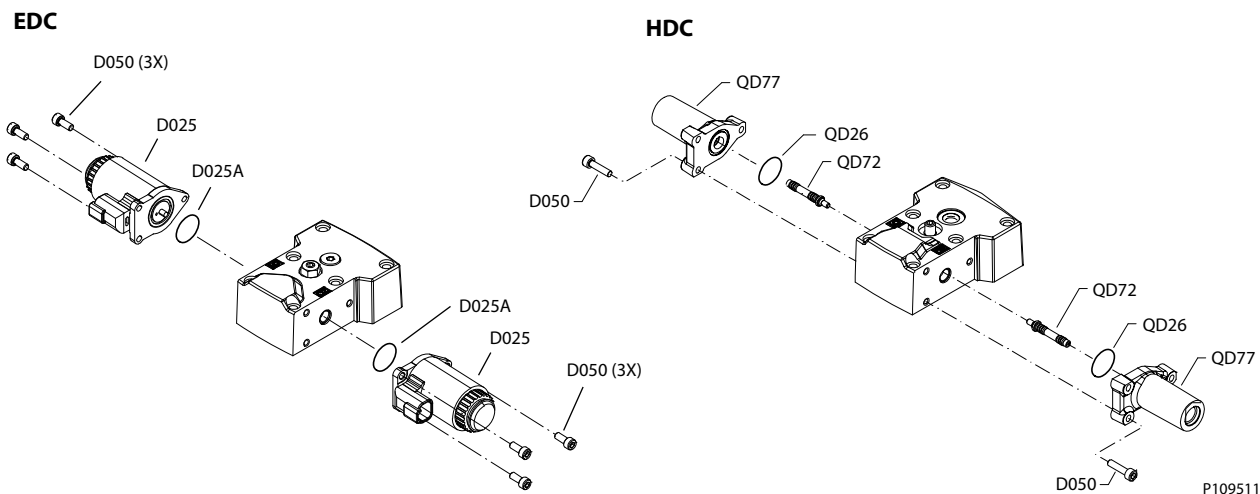

#### Identification and torque

Item	Description	Wrench size	Torque
D025	Solenoid	-	-
D025A	O-ring	-	-
D050	Cap screw	4 mm	8 Nm [6 lbf·ft]
QD26	O-ring	-	-
QD77	Actuator housing	-	-
QD72	Actuator pin	-	-



## Minor repair

### MDC Control

#### MP1 MDC control removal

Follow the steps to safely remove the MDC control.

1. Use a 5 mm internal hex wrench to remove the six cap screws (D250).
2. Remove the control module and gasket (D150) and discard the gasket.
3. Optional: If necessary, remove servo orifices (F00A, F00B), supply orifice (F00P), and tank orifices (F00T) using a 3 mm internal hex wrench.

It is recommended to tag the orifices for an easier re-installation process.

**The functionality of the control and the neutral position of the pump may be lost if the control is disassembled.**

**Do not disassemble the control module.**

Before removing the control, note the position of the control lever for reassembly.

#### MDC Illustration

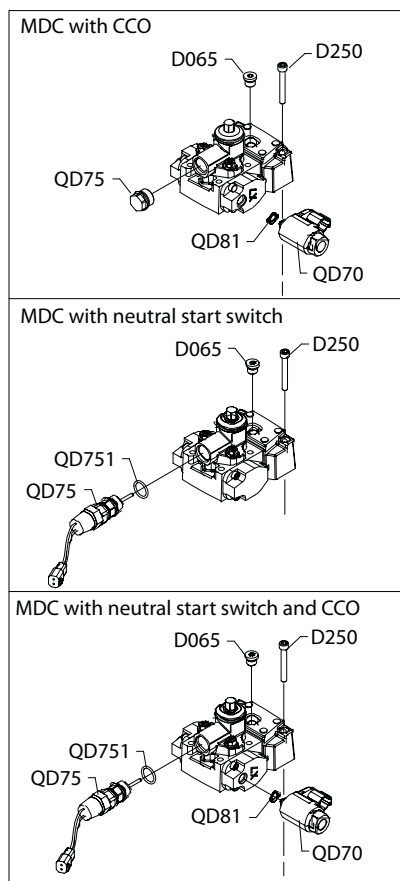
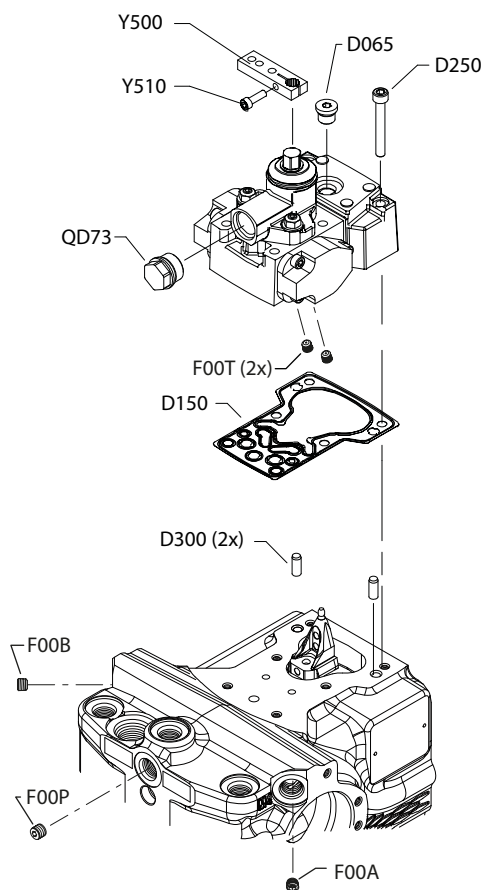

## Minor repair

### MDC Legend

#### Wrench size and torque

Item	Description	Wrench size	Torque
D065	O-ring plug	3/16	12 N·m [9 lbf·ft]
D250	cap screw	5 mm	13.3 Nm [9.8 lbf·ft]
QD70	solenoid	-	-
QD81	O-ring	-	-
QD75	neutral start switch assembly	-	-
QD751	O-ring	-	-
QD73	plug	3/4 inch	
F00A	servo orifice	7/16 inch	7.9 Nm [5.8 lbf·ft]
F00B	servo orifice	7/16 inch	7.9 Nm [5.8 lbf·ft]
F00P	supply orifice	1/4 inch	14 Nm [10.8 lbf·ft]
F00T	tank orifice	3 mm	2.5 Nm [1.8 lbf·ft]
Y020	cap screw	5 mm	13.3 Nm [9.8 lbf·ft]

### Controls inspection

Inspect the machined surfaces on the control pump housing. Inspect plastic PC board housing and its sealing areas. If any damage is found, replace the damaged components.

Controls are available as a complete unit. Do not disassemble the control.

### MDC Control Assembly

Ensure you install dowel pins (D300) in housing before installing control.

**The pump will lose control, causing a potentially hazardous situation.**

**If a feedback pin comes off during operation, ensure the feedback pin is properly torqued before continuing with reassembly.**

1. Install a new gasket (D150).
2. If you removed screen (D084), install a new one with the mesh facing outward.
3. Install retaining ring (D098).

*Proper screen orientation*

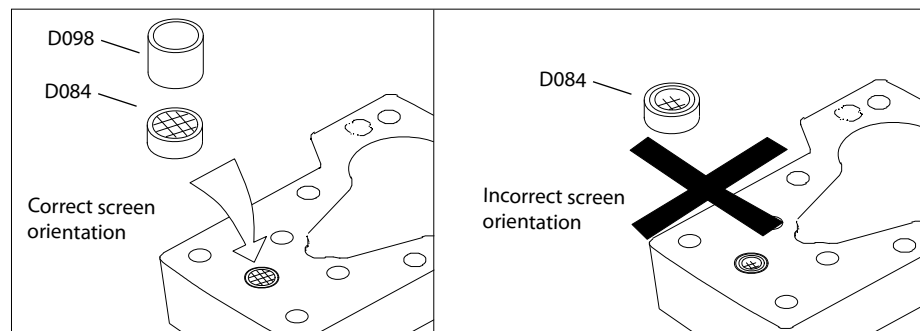

Remove plug on top of control to ensure the swashplate feedback pin is properly positioned in the center of the control module when installing control.

**Minor repair**

4. If previously removed, install orifices using a 3 mm internal hex wrench and torque to 2.5 N•m [1.8 lbf•ft].
5. Install the control module and six cap screws (D250).
6. Using a 5 mm internal hex wrench, torque the cap screws (D250) to 13.3 N•m [9.8 lbf•ft].

*Torque sequence*

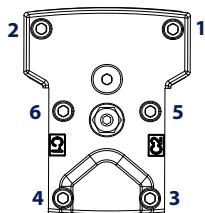

## Minor repair

### Automotive control

#### Automotive control removal

1. Drain pump completely before removing control. Disconnect and remove wiring (D640).
2. Fabricate a special tool to remove two plastic plugs (D610). See drawing below for tool dimensions. Push down on plug and turn 45 degrees counterclockwise. Discard plugs.

Wax seals will be destroyed when the plugs are removed. Do not damage the housing in the plug sealing area.

3. Use a 5 mm internal hex to remove two screws (D674). Remove shield (D672).
4. Use a 5 mm internal hex to remove six screws (D250). Remove control from pump.
5. Remove and discard gasket (D150).

Alignment pins are pressed into control. Do not remove them.

6. If necessary, use a 3 mm hex wrench to remove orifices (F00A, F00B) from housing. Tag each orifice for re-installation. Each orifice may be a different size.
7. If it is necessary to remove the screens (D084), drill out screen retention ring (D098) and remove and discard screen. Note screen orientation for proper reassembly.

#### Warning

Do not allow metal fragments to fall into control housing. This may cause erratic pump operation.

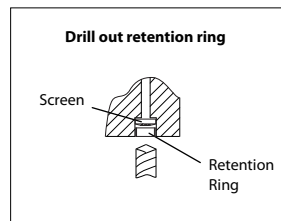
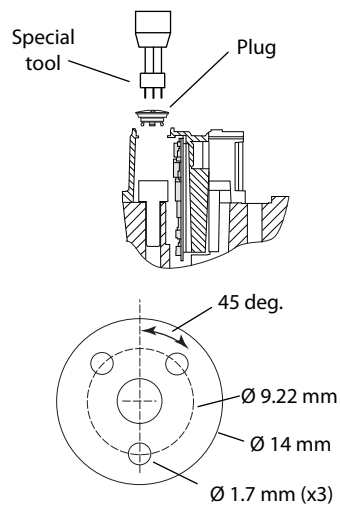

P108021

## Minor repair

### Remove control

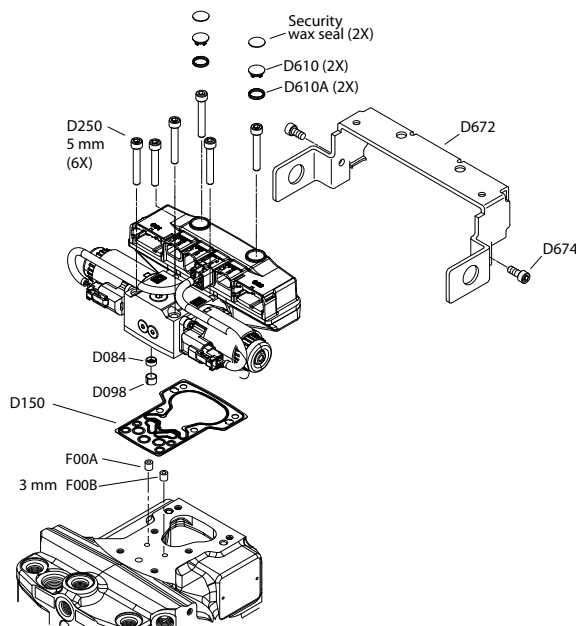

### Controls inspection

Inspect the machined surfaces on the control pump housing. Inspect plastic PC board housing and its sealing areas. If any damage is found, replace the damaged components.

Controls are available as a complete unit. Do not disassemble the control.

### Automotive control installation

1. If previously removed, install new screen (D084) in original orientation. Press in new retention ring (D098). Be sure screen will not move axially in bore after retention ring is installed.

#### **Warning**

Failure to install screen will result in erratic pump operation.

2. If previously removed, use a 3 mm hex wrench to install orifices (F00A, F00B) in original orientation. Torque to 5 N·m [1.8 lbf·ft].
3. Install new gasket (D150) to bottom of control.
4. Install control on pump. Use a 5 mm hex wrench to install six screws (D250). Torque to 13.3 N·m [9.8 lbf·ft]. Follow torque sequence shown in [gwa1450814089626.xml](#).

Do not damage the plastic housing when installing the screws.

5. Connect wiring (D640).
6. Use the specially fabricated tool to install new plastic plugs with O-rings (D610). Press in and turn 45 degrees clockwise.

If control will continue to be under warranty, install new sealing wax. Pumps without sealing wax installed will not be warrantied.

7. Install protection bracket (D672). Install screws (D674). Torque to 5 N·m [3.7 lbf·ft].

If pump has been rebuilt or a new control is being installed, control software must be re-calibrated. Refer to Automotive Control User Manual for re-calibration instructions.

Minor repair

*Install control*

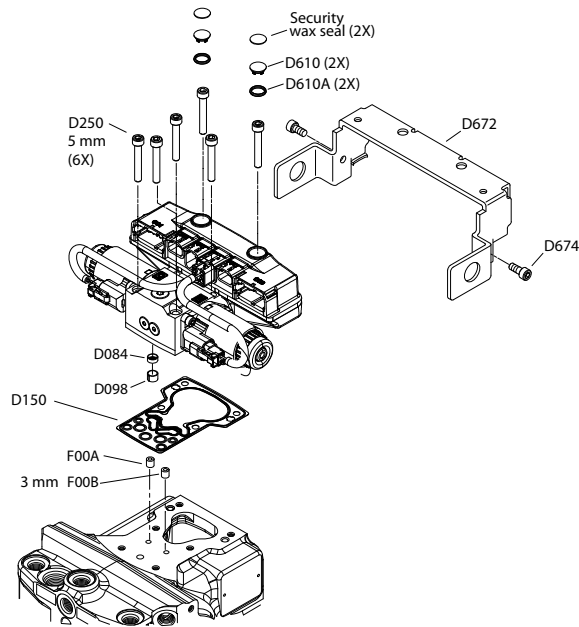

*Special plug installation tool*

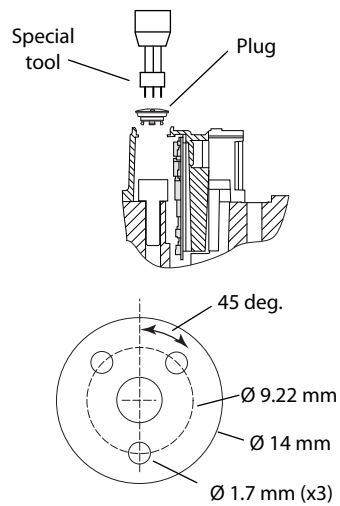

**Minor repair**

**Charge Pump**

If the pump has an auxiliary pump attached, remove the auxiliary pump and connecting shaft before removing the auxiliary pad.

**MP1 charge pump removal**

1. Position pump so end cover or auxiliary pad (K100) is on top.
2. Remove end cover/auxiliary pad screws (K300) using an 8 mm internal hex wrench.
3. Remove and discard O-ring (K200).
4. Remove coupling (K500). Use a small hook if necessary.
5. Remove the charge pump (K400).

**MP1 charge pump torque information**

*Charge pump removal (38/45 shown)*

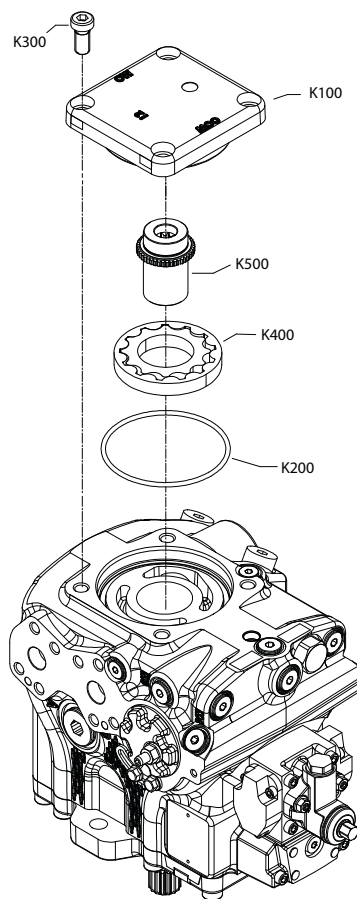

P108949

*Identification and torque*

Item	Wrench size	Torque
Screw (K300)	8 mm	111 N·m [81.9 lbf·ft]

**Minor repair****MP1 charge pump inspection**

Inspect the components for wear, scratches or pitting. Scratches on these components will cause a loss of charge pressure. If any component shows signs of wear, scratching or pitting, replace it.

**MP1 charge pump assembly**

1. Lubricate and install charge pump (K400).
2. Install coupling (K500).
3. Lubricate and install a new O-ring (K200).
4. Install cover/aux pad (K100).

---

Pay attention to the orientation of the cover/pad. In the case of counterclockwise rotation, when the pump control is placed on the upper side, the CCW character on the cover should be on the upper side.

---

5. Install screws (K300). Torque screws per table.



**Minor repair**

**High Pressure Relief Valve (HPRV)**

**MP1 HPRV valve removal**

Follow these steps to safely remove the high pressure relief valves.

1. Using a 5/16 inch hex wrench, remove the HPRV's (N100/M100).
2. Remove and discard the O-rings (M023) and backup rings (M022).

**MP1 HPRV torque information**

*HPRV valves removal*

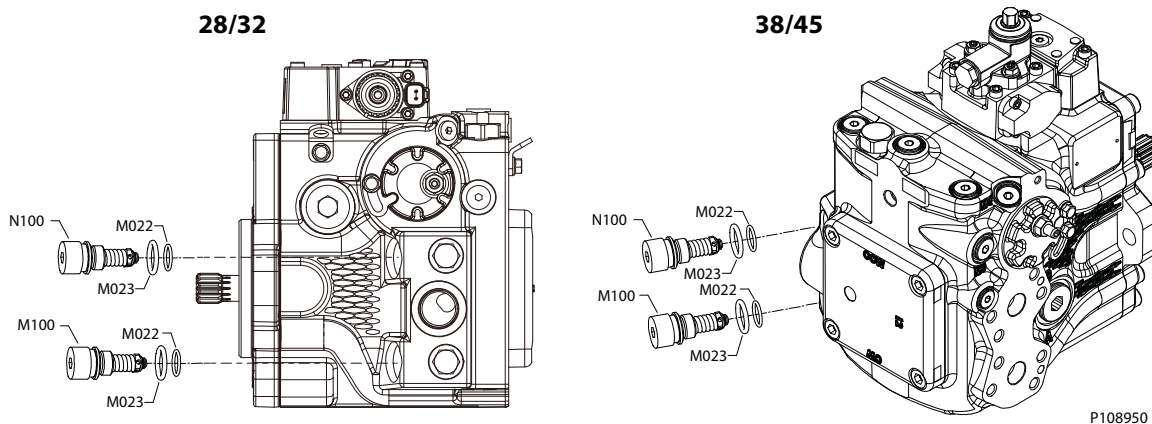

P108950

*Identification and torque*

Item	Wrench size	Torque
HPRV Valve (N100/M100)	5/16 inch	81.0 N•m [59.7 lbf•ft]

**HPRV valve inspection**

Inspect the sealing surfaces in the pump for nicks or scratches. Check the high pressure relief valves for damage. Replace any damaged components.

**HPRV Valve Reassembly**

1. Lubricate and install new O-rings (M022) and backup rings (M023).
2. Install the HPRV valves. Torque to the value shown in the table.
3. Operate the vehicle/machine through its full range of control to ensure proper operation. Check for leaks.

**Minor repair**

**Charge Pressure Relief Valve (CPRV)**

**MP1 CPRV removal**

Follow these steps to safely remove the charge pressure relief valves.

1. Using a 1 inch wrench, remove the CPRV plug (V100).
2. Remove and discard O-ring (QV110).
3. Use a small hook or magnet to remove washer(s) (V200), spring (V300), and seat (V400).

**MP1 CPRV torque information**

*CPRV removal (38/45 shown)*

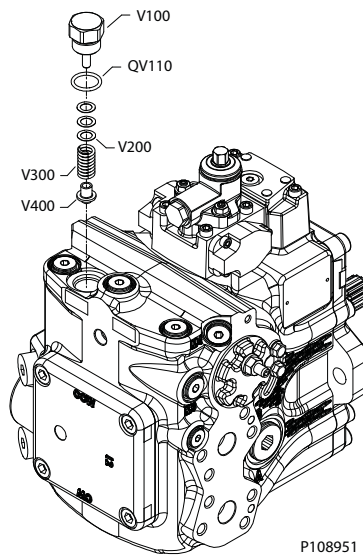

*Identification and torque*

Item	Wrench size	Torque
CPRV (V100)	1 inch	78.6 N·m [58.0 lbf·ft]

**CPRV inspection**

Inspect washer, spring, and seat. Replace charge pressure relief valve if damage is found. Inspect the sealing surfaces of the pump for nicks or scratches.

**MP1 CPRV assembly**

1. Install seat (V400), spring (V300), and washer (V200) into the housing.
2. Install new O-ring (QV110) onto the CPRV plug (V100).
3. Install CPRV plug in housing. Torque per table.

**Minor repair**

**MP1 loop flushing removal (28/32 pictured)**

1. Using an 11/16 inch hex wrench, remove plug (L150).
2. Using a ¼ inch hex wrench, remove plug (G115).
3. Remove and discard O-ring (9Q50A).
4. Remove loop flushing spool (L100).
5. Using a 4 mm hex wrench, remove orifice (L200).

**MP1 loop flushing torque information**

*Loop flushing removal*

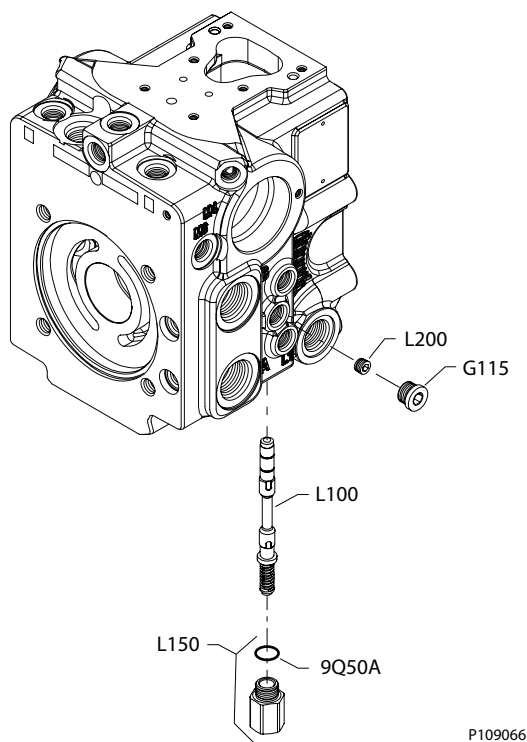

*Identification and torque*

Item	Wrench size	Torque
Plug (L150)	11/16 inch	32 N•m [24 lbf•ft]
Orifice (L200)	4 mm	7.2 N•m [5.3 lbf•ft]
Plug (G115)	1/4 inch	40 N•m [30 lbf•ft]

## Minor repair

### MP1 loop flushing spool inspection

Inspect loop flushing spool and spring. If damage or wear is found, replace spool and spring.



P109067

### Reassembly

1. Lubricate and install loop flushing spool (L100).
2. Lubricate and install new O-ring (9Q50A).
3. Using a 11/16 inch wrench, torque plug (L150) to 32 N·m [24 lbf·ft].
4. Using a 4 mm hex wrench, torque orifice (L200) to 7.2 N·m [5.3 lbf·ft].
5. Using a 1/4 inch hex wrench, torque plug (G115) to 40 N·m [30 lbf·ft].

## Shaft Removal

The shaft assembly is serviceable without disassembling the pump.

1. Position the pump with the shaft pointing up.
2. Remove the first spring clip (J300).
3. Carefully remove and discard the shaft seal (J250)

**⚠ Caution**

**Do not damage the housing bore, shaft or bearing when removing the shaft and shaft seal.**

4. Remove the second spring clip (J300).
5. Pull the shaft and bearing out of the housing.
6. Remove the retaining ring (J200). Press the bearing (J150) off the shaft (J100).

*Shaft removal (38/45 shown)*

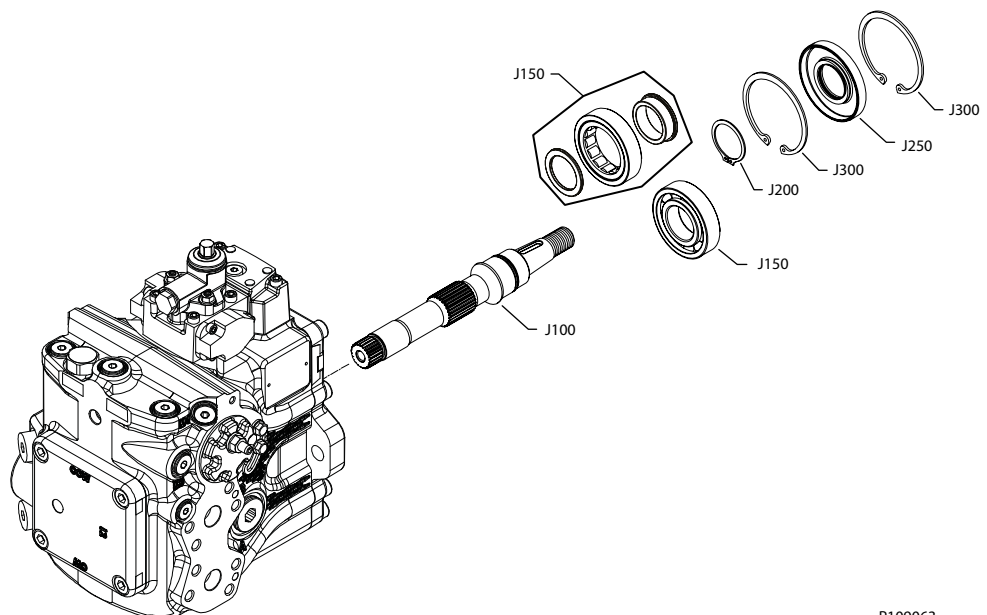

P109063

**Minor repair****Inspection**

Inspect the shaft journals for wear, scratching, and pits. Check the splines for fretting; replace if damaged. Rotate the bearing, if it does not rotate smoothly, replace it.

**Shaft Reassembly**

1. Press the bearing (J150) onto the shaft (J100) and replace the retaining ring (J200).
2. Install the shaft/bearing assembly into the pump.
3. Install first spring clip (J300).
4. Cover the shaft with a protective sleeve while installing the seal. Lubricate and install the seal.
5. Install the second spring clip (J300).

**Fastener size and torque chart**

**MP1 fastener size and torque**

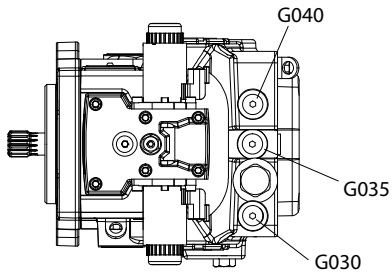

**28/32**

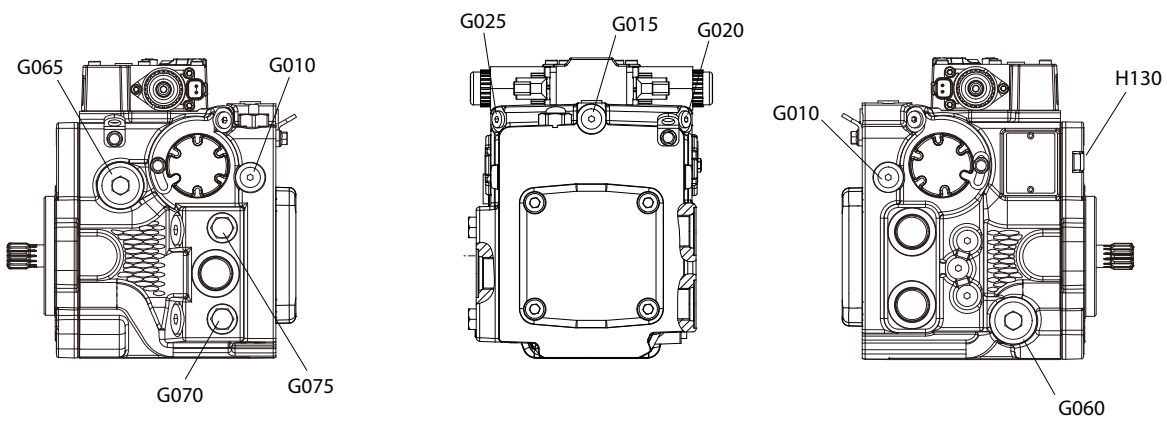

**38/45**

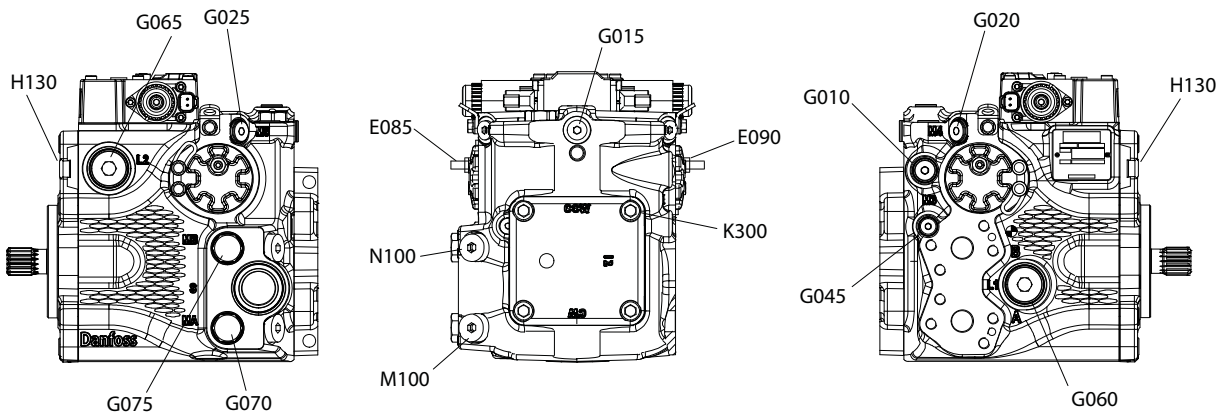
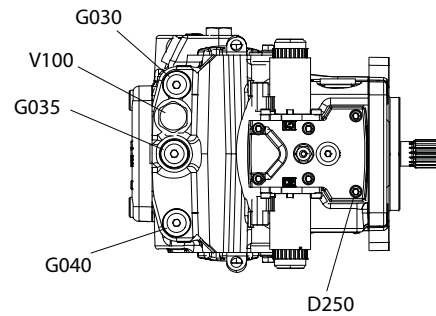

**Fastener size and torque chart**

Item	Fastener	Wrench size	Torque
D250	Electric control mounting bolt	5 mm	13 N•m [10 lbf•ft]
E085	Displacement limiter screw	4 mm	NA
E090	Displacement limiter sealnut	13 mm	23 N•m [17 lbf•ft]
H130	Front cover bolt	8 mm	64 N•m [47 lbf•ft]
K300	Rear cover/aux pad mounting bolt	8 mm	111 N•m [82 lbf•ft]

**MP1 plug size and torque**

Item	O-ring plug	Wrench size	Torque
G010/G035	Charge pressure gauge	6 mm or 1/4 inch	40 N•m [29.5 Ft-lbs] for 9/16 35.3 N•m [26 Ft-lbs] for M14
G030/G040	Filtration inlet/outlet	6 mm or 1/4 inch	40 N•m [29.5 Ft-lbs] for 9/16 35.3 N•m [26 Ft-lbs] for M14
G020/G025	Servo gauge (28/32)	6 mm or 3/16 inch	19 N•m [18.4 Ft-lbs] for 7/16 25 N•m [18.4 Ft-lbs] for M12
G020/G025	Servo gauge (38/45)	6 mm or 1/4 inch	40 N•m [29.5 Ft-lbs] for 9/16 35.3 N•m [26 Ft-lbs] for M14
G060/065	Case drain	12 mm or 9/16 inch	48 N•m [36 Ft-lbs]
G070/075	System gauge (28/32)	19 mm or 11/16 inch	38 N•m [28 Ft-lbs] for 9/16 24 N•m [17.7 lbf-ft] for M14
	System gauge (38/45)	24 mm or 7/8 inch	81 N•m [59.7 Ft-lbs] for 3/4 67 N•m [49.4 lbf-ft] for M18
M100/N100	High pressure relief	5/16 inch	81.0 N•m [59.7 Ft-lbs]
V100	Charge pressure relief	1 inch	78.6 N•m [58 Ft-lbs]

**Products we offer:**

- Cartridge valves
- DCV directional control valves
- Electric converters
- Electric machines
- Electric motors
- Gear motors
- Gear pumps
- Hydraulic integrated circuits (HICs)
- Hydrostatic motors
- Hydrostatic pumps
- Orbital motors
- PLUS+1® controllers
- PLUS+1® displays
- PLUS+1® joysticks and pedals
- PLUS+1® operator interfaces
- PLUS+1® sensors
- PLUS+1® software
- PLUS+1® software services, support and training
- Position controls and sensors
- PVG proportional valves
- Steering components and systems
- Telematics

**Danfoss Power Solutions** is a global manufacturer and supplier of high-quality hydraulic and electric components. We specialize in providing state-of-the-art technology and solutions that excel in the harsh operating conditions of the mobile off-highway market as well as the marine sector. Building on our extensive applications expertise, we work closely with you to ensure exceptional performance for a broad range of applications. We help you and other customers around the world speed up system development, reduce costs and bring vehicles and vessels to market faster.

Danfoss Power Solutions – your strongest partner in mobile hydraulics and mobile electrification.

**Go to [www.danfoss.com](http://www.danfoss.com) for further product information.**

We offer you expert worldwide support for ensuring the best possible solutions for outstanding performance. And with an extensive network of Global Service Partners, we also provide you with comprehensive global service for all of our components.

Local address:

**Hydro-Gear**

[www.hydro-gear.com](http://www.hydro-gear.com)

**Daikin-Sauer-Danfoss**

[www.daikin-sauer-danfoss.com](http://www.daikin-sauer-danfoss.com)

**Danfoss  
Power Solutions (US) Company**  
2800 East 13th Street  
Ames, IA 50010, USA  
Phone: +1 515 239 6000

**Danfoss  
Power Solutions GmbH & Co. OHG**  
Krokamp 35  
D-24539 Neumünster, Germany  
Phone: +49 4321 871 0

**Danfoss  
Power Solutions ApS**  
Nordborgvej 81  
DK-6430 Nordborg, Denmark  
Phone: +45 7488 2222

**Danfoss  
Power Solutions Trading  
(Shanghai) Co., Ltd.**  
Building #22, No. 1000 Jin Hai Rd  
Jin Qiao, Pudong New District  
Shanghai, China 201206  
Phone: +86 21 2080 6201

Danfoss can accept no responsibility for possible errors in catalogues, brochures and other printed material. Danfoss reserves the right to alter its products without notice. This also applies to products already on order provided that such alterations can be made without subsequent changes being necessary in specifications already agreed. All trademarks in this material are property of the respective companies. Danfoss and the Danfoss logotype are trademarks of Danfoss A/S. All rights reserved.