

ENGINEERING
TOMORROW



Quick Select Guide—2024

Products and technologies for all your application needs, today and **tomorrow**

REFRIGERATION & AIR CONDITIONING COMPONENTS

Easy

Find the right products fast with our Quick Select Guide



Danfoss
North America



Danfoss
North America

choose.danfoss.com

Table of Contents

Thermostatic Expansion Valves	4
T2 / TE2 - Thermostatic Expansion Valves and Kits	4
TUA/TUAE - Thermostatic Expansion Valves and Kits	8
TUA - Thermostatic Expansion Valves for Ice Machines	12
TR6 - Thermostatic Expansion Valves and Kits	14
TGE - Thermostatic Expansion Valves	16
Thermostats and Pressure Switches	18
ERC 213 - Electronic Temperature Control	18
KPU 19 - Thermostats	20
KPU 60/70 - Thermostats	22
KPU - Pressure Switches	24
MP - Differential Pressure Switch / Lube Oil Protection Switch	26
Solenoid Valves	28
EVR Version 2 - Solenoid Valves	28
Pressure Regulators	30
KVP - Evaporating Pressure Regulators	30
KVL - Crankcase Pressure Regulators	30
KVR - Condensing Pressure Regulator	30
NRD - Differential Pressure Regulators	30
KVC - Hot Gas Bypass Pressure Regulators	30
CPCE - Hot Gas Bypass Pressure Regulators	30
Filter Driers	32
DCL - Liquid Line Filter Driers	32
DCB - Bi-flow Filter Driers	32
DAS - Suction Line Filter Driers	32
DCR - Filter Drier Cores	32
DCL with Schrader Valve - Filter Driers	34
Ball Valves	35
GBC V2 - Ball Valves	35
Check Valves	36
NRV V2 - Check Valves	36
Sight Glasses	37
SGP - Sight Glasses	37
Condensing Units	38
Optyma™ - Condensing Units	38
Optyma™ Slim - Low Ambient Outdoor Condensing Units	46
Reciprocating Compressors	54
MT / MTZ - Medium/High Temperature Reciprocating Compressors	54
NTZ - Low Temperature Reciprocating Compressors	57
Scroll Compressors	59
H Series - Residential and Light Commercial Scroll Compressors	59
S Series - Light Commercial and Commercial Scroll Compressors	62
DSH Series - Light Commercial and Commercial Scroll Compressors with Intermediate Discharge Valves	64

T2 / TE2 - Thermostatic Expansion Valves

Danfoss T2/TE2 brass body thermostatic expansion valves feature flare inlet and outlet connections. By pairing one valve body with one of eight replaceable orifices, a contractor can satisfy applications from $-40\text{ }^{\circ}\text{F}$ to $+50\text{ }^{\circ}\text{F}$ and from $\frac{1}{8}$ to $5\frac{3}{4}$ tons capacity (see capacity chart for specifics).

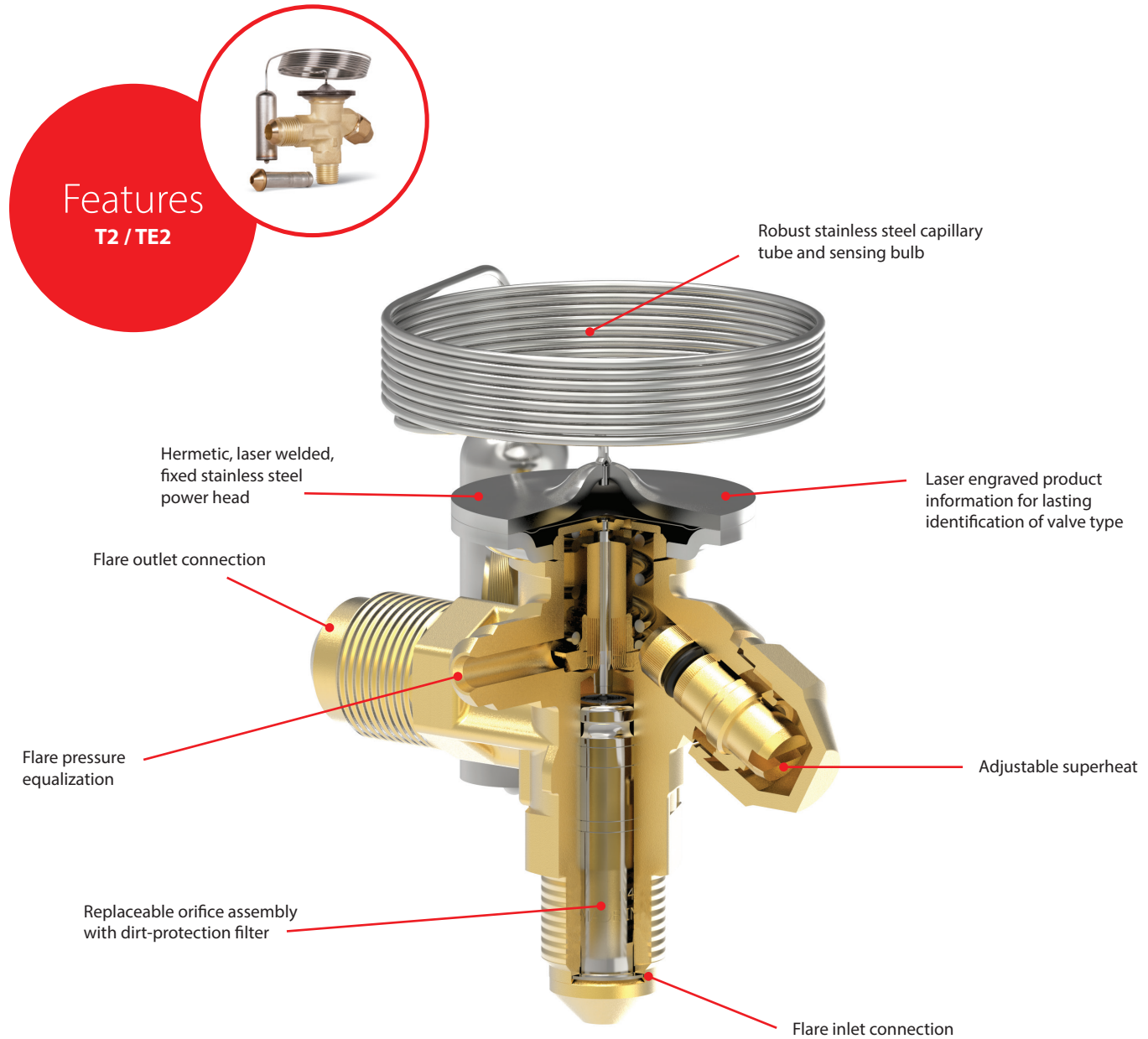

Facts

Applications:

- Commercial refrigeration
- Self-contained refrigerators
- Transport refrigeration
- Supermarket refrigeration
- Temperature range: $-40\text{ }^{\circ}\text{F}$ to $+50\text{ }^{\circ}\text{F}$
- Capacity range: $\frac{1}{8}$ to $5\frac{3}{4}$ tons (varies by refrigerant)
- Refrigerants: R-22, R-407C, R-134a, R-404A, R-448A, R-449A
- Functional valve consists of valve body and orifice
- Flare/solder adaptor available

Product Selection

1. Select Valve Body

Equalization	R-22	R-407C	R-404A	R-134a	R-448A	R-449A
Internal	068Z3206		068Z3400	068Z3346		068Z3728
External	068Z3209		068Z3403	068Z3348		068Z3727

All valves above have 3/8 in. x 1/2 in. flare connections and are designed for evaporator temperatures -40 °F to 50 °F (N charge). Other variations available, please contact your local Danfoss authorized wholesaler.

2. Select Orifice

A. T2/TE2 valve capacities are based on the installed orifice. To select the correct size, use one of the two methods below:

A. System characteristics: Select the orifice using appropriate refrigerant, evaporator temperature, and system capacity.

OR

B. Nominal capacity of the installed valve: Use the nominal capacity of the originally installed valve and match with the nominal capacity in chart (3rd column from left).

Technical data and ordering

T2 and TE2 (IF EXACT CAPACITY CANNOT FOUND, USE NEXT LARGER ORIFICE)

R-22		R-407C	Evaporator temperature (°F)										
Orifice size	Danfoss Code No.	Nominal capacity of installed valve ¹ (tons)	-40	-30	-20	-10	0	10	20	30	40	50	
			Rated capacity ² (tons)										
0X	068-2002	1/4	1/8	1/4	1/4	1/4	1/4	1/4	1/4	1/4	1/4	1/4	
00	068-2003	1/2	1/4	1/3	1/3	1/3	1/3	1/3	1/2	1/2	1/2	1/2	
01	068-2010	1	1/3	1/3	1/2	1/2	1/2	3/4	3/4	3/4	1	1	
02	068-2015	1 1/2	1/3	1/2	1/2	3/4	3/4	1	1	1 1/4	1 1/3	1 1/3	
03	068-2006	2 1/2	3/4	3/4	1	1	1 1/3	1 1/2	1 3/4	2	2 1/4	2 1/3	
04	068-2007	3 1/2	1	1	1 1/2	1 3/4	2	2 1/3	2 3/4	3	3 1/2	3 1/2	
05	068-2008	5	1 1/3	1 3/4	2	2 1/3	2 3/4	3	3 3/4	4 1/4	4 3/4	5	
06	068-2009	5 1/2	1 1/2	2	2 1/3	2 3/4	3	3 3/4	4 1/3	5	5 1/2	5 3/4	

R-404A		Evaporator temperature (°F)										
Orifice size	Danfoss Code No.	Nominal capacity of installed valve ¹ (tons)	-40	-30	-20	-10	0	10	20	30	40	50
			Rated capacity ² (tons)									
0X	068-2002	1/6	1/8	1/6	1/6	1/6	1/6	1/5	1/5	1/5	1/5	1/6
00	068-2003	1/3	1/5	1/5	1/4	1/4	1/3	1/3	1/3	1/3	1/3	1/3
01	068-2010	3/4	1/4	1/3	1/3	1/3	1/2	1/2	1/2	3/4	3/4	3/4
02	068-2015	1	1/4	1/3	1/3	1/2	1/2	3/4	3/4	1	1	1
03	068-2006	1 3/4	1/2	1/2	3/4	3/4	1	1 1/3	1 1/2	1 3/4	1 3/4	1 3/4
04	068-2007	2 3/4	3/4	3/4	1	1 1/3	1 1/2	2	2 1/3	2 1/2	3	3
05	068-2008	3 3/4	1	1	1 1/2	1 3/4	2	2 1/2	3	3 1/2	3 3/4	4
06	068-2009	4 1/2	1	1 1/3	1 3/4	2	2 1/2	3	3 3/4	4	4 1/2	4 1/2

R-134a		Evaporator temperature (°F)										
Orifice size	Danfoss Code No.	Nominal capacity of installed valve ¹ (tons)	-40	-30	-20	-10	0	10	20	30	40	50
			Rated capacity ² (tons)									
0X	068-2002	1/5	1/8	1/6	1/6	1/6	1/6	1/5	1/5	1/5	1/5	1/5
00	068-2003	1/3	1/6	1/5	1/5	1/5	1/4	1/4	1/4	1/3	1/3	1/3
01	068-2010	1/2	1/5	1/4	1/4	1/3	1/3	1/3	1/2	1/2	1/2	1/2
02	068-2015	3/4	1/4	1/4	1/3	1/3	1/3	1/2	1/2	1/2	3/4	3/4
03	068-2006	1 1/2	1/3	1/3	1/2	1/2	3/4	3/4	1	1	1 1/4	1 1/3
04	068-2007	1 3/4	1/2	1/2	3/4	3/4	1	1 1/4	1 1/3	1 1/2	1 3/4	2
05	068-2008	2 1/3	3/4	3/4	1	1	1 1/3	1 1/2	1 3/4	2	2 1/3	2 1/2
06	068-2009	3	3/4	1	1 1/4	1 1/3	1 1/2	2	2 1/4	2 1/2	2 3/4	3

R-448A			Evaporator temperature (°F)					
Orifice size	Danfoss Code No.	Nominal capacity of installed valve ³ (tons)	-40	-20	0	20	40	50
			Rated capacity ² (tons)					
0X	068-2002	¼	¼	¼	¼	¼	¼	¼
00	068-2003	½	⅓	⅓	⅔	½	½	½
01	068-2010	1	⅔	½	¾	⅞	1	1
02	068-2015	1 ⅓	½	⅔	¾	1 ½	1 ⅔	1 ½
03	068-2006	2 ½	¾	1	1 ⅓	1 ⅞	2 ½	2 ½
04	068-2007	3 ⅓	1 ½	1 ⅔	2	2 ½	3 ⅔	4
05	068-2008	4 ⅓	1 ⅔	2	2 ¾	3 ⅔	4 ¾	5 ½
06	068-2009	5 ⅓	1 ¾	2 ½	3 ⅓	4 ½	5 ¾	6 ¼

R-449A			Evaporator temperature (°F)					
Orifice size	Danfoss Code No.	Nominal capacity of installed valve ³ (tons)	-40	-20	0	20	40	50
			Rated capacity ² (tons)					
0X	068-2002	¼	¼	¼	¼	¼	¼	¼
00	068-2003	½	⅓	⅓	⅔	½	½	½
01	068-2010	1	⅔	½	¾	⅞	1	1
02	068-2015	1 ½	½	⅔	¾	1	1 ½	1 ½
03	068-2006	2 ½	¾	1	1 ⅓	1 ⅞	2 ⅔	2 ½
04	068-2007	3 ⅔	1 ¼	1 ⅔	2	2 ¾	3 ½	3 ⅔
05	068-2008	4 ½	1 ⅔	2	2 ¾	3 ⅔	4 ⅔	5
06	068-2009	5 ⅔	1 ⅞	2 ½	3 ¼	4 ½	5 ⅔	6

All capacity data is in accordance to ARI 750-2007 except where noted.

¹ Nominal capacity based on ARI standards: Evaporating temperature = 40 °F, Liquid temperature = 100 °F, Condensing temperature = 110 °F

² Capacity based on condensing temperature of 95 °F and a vapor free liquid temperature of 88 °F ahead of the expansion valve.

³ Condensing temperature = 100 °F

Spare Parts and Accessories

Description	Danfoss Code No.
Bulb strap	068U3507

Selection and Installation Instructions

1. Select Valve Body

Select the valve body based on refrigerant and need for internal or external equalization using the table on the previous page under “Select Valve Body.”

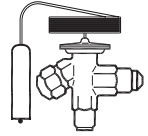

2. Select Orifice

T2/TE2 valve capacities are based on the installed orifice. To select the correct size orifice, use one of the two methods using the “Select Orifice” section on the previous page.



3. Assemble Valve and Install into System

1. Slide the orifice into the valve body and secure using liquid line flare nut
2. Attach evaporator inlet or distributor assembly to valve outlet flare nut
3. Tighten both flare nuts
 - Specification for inlet is 26–33 ft.-lbs
 - Specification for outlet is 37–52 ft.-lbs
4. Secure sensing bulb with enclosed bulb strap to suction line. Bulb should be located between 1:00 & 4:00 or 8:00 & 11:00 on the tube, and the strap should be tight enough that no bulb movement is possible.
5. Wrap included insulation tape beginning one inch before the bulb and overlapping each wrap, finishing one inch beyond the bulb on the other end.

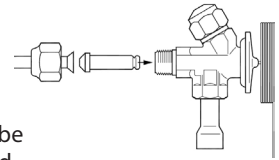

4. Adjust Superheat

1. Remove the cap
2. Make superheat adjustments ¼ turn at a time (¼ turn ≈ 1.75 °F).
 - Turning clockwise increases superheat.
 - Turning counter-clockwise decreases superheat.
3. Reinstall the cap



Easy to carry kits for truck stock

All T2/TE2 valve bodies and orifice featured on the next page and a hex key for superheat adjustment.

068Z7100

Both TUA/TUAE valve bodies and orifices and T2/TE2 and orifices plus gaskets for TUA/TUAE and a hex key for superheat adjustment.

068U7001

Kits are plastic cases with foam inserts, all valves and orifices, and instructions for selection and installation of the valves. Empty kits and foam available upon request.

TUA / TUAE - Thermostatic Expansion Valves

Danfoss TUA/TUAE stainless steel thermostatic expansion valves feature solder inlet and outlet connections. By pairing one valve body with one of ten replaceable orifices, a contractor can satisfy applications from $-40\text{ }^{\circ}\text{F}$ to $+50\text{ }^{\circ}\text{F}$ and up to $4\frac{1}{2}$ tons capacity (see capacity chart for specifics).

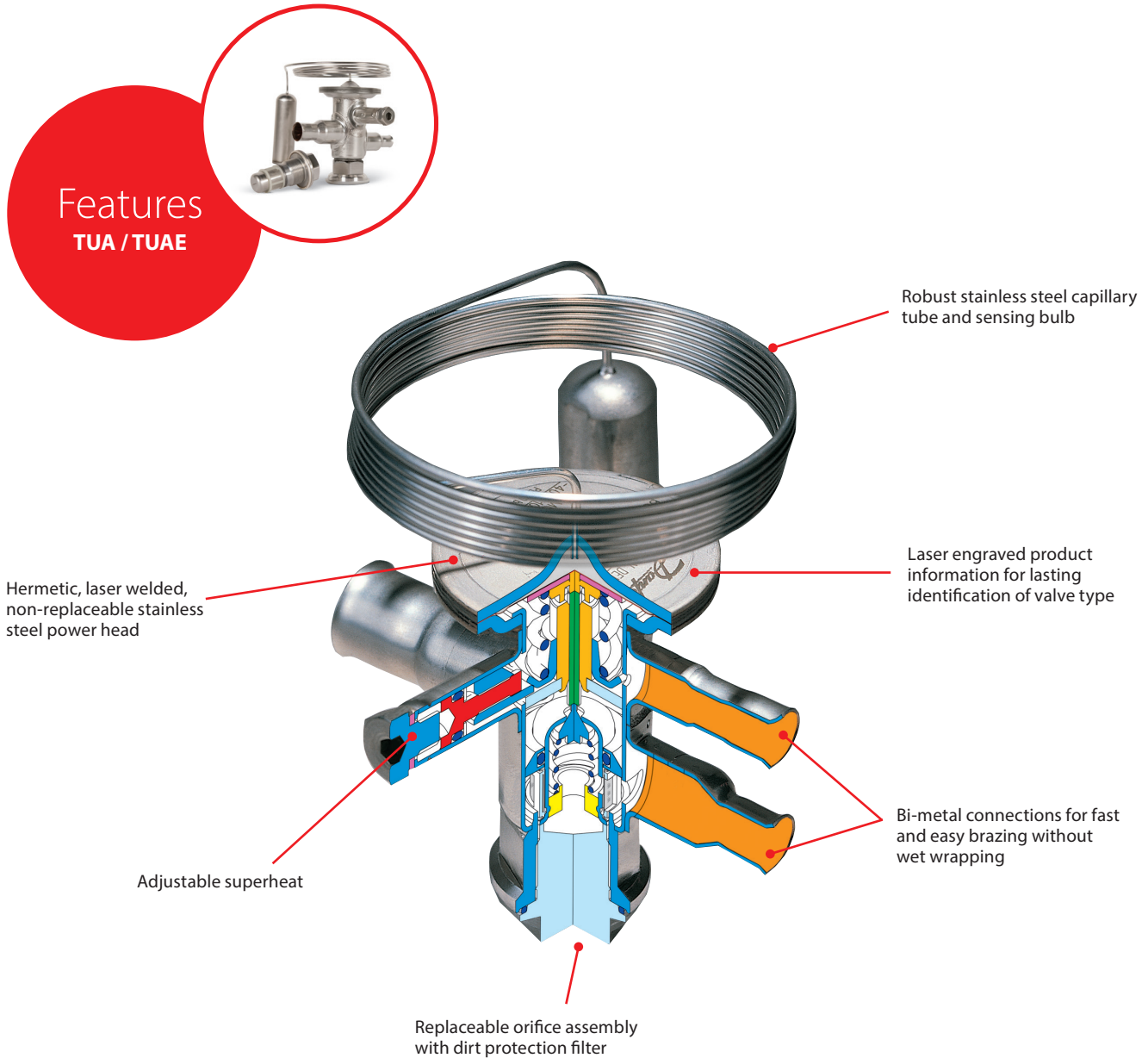

Facts

Applications:

- Traditional refrigeration
- Self-contained refrigerators
- Transport refrigeration
- Supermarket refrigeration
- Temperature range: $-40\text{ }^{\circ}\text{F}$ to $+50\text{ }^{\circ}\text{F}$
- Capacity range: $\frac{1}{8}$ to $4\frac{1}{2}$ tons (varies by refrigerant)
- Refrigerants: R-22, R-407C, R-134a, R-404A, and R448/9A
- Functional valve consists of valve body and orifice

Scan the QR Code for a video with more information on the TUA valve features and installation or visit <http://bit.ly/TUAINSTALL>



Product Selection

1. Select Valve Body

Equalization	R-22	R-407C	R-404A	R-134a	R-448A	R-449A
Internal	068U2235		068U2285	068U2205	068U3945	068U3946
External	068U2237		068U2287	068U2207	068U3859	068U3858

All valves above have 3/8 in. x 1/2 in. solder ODF connections and are designed for evaporator temperature -40 °F to 50 °F (N charge). Other variation available, please contact your local Danfoss authorized wholesaler.

2. Select Orifice

TUA/TUAE valve capacities are based on the installed orifice. To select the correct size, use one of the two methods below:

A. System characteristics: Select the orifice using appropriate refrigerant, evaporator temperature, and system capacity.

OR

B. Nominal capacity of the installed valve: Use the nominal capacity of the originally installed valve and match with the nominal capacity in chart (3rd column from left).

Technical data and ordering

TUA and TUAE (IF EXACT CAPACITY CANNOT BE FOUND, USE NEXT LARGER ORIFICE)

R-22			R-407C			Evaporator temperature (°F)							
Orifice size	Danfoss Code No.	Nominal capacity of installed valve ¹ (tons)	-40	-30	-20	-10	0	10	20	30	40	50	
			Rated capacity ² (tons)										
0	068U1030	1/8	1/15	1/15	1/15	1/10	1/8	1/8	1/6	1/6	1/6	1/5	
1	068U1031	1/5	1/10	1/8	1/8	1/6	1/6	1/5	1/5	1/5	1/4	1/4	
2	068U1032	1/4	1/10	1/8	1/8	1/6	1/5	1/4	1/4	1/4	1/3	1/3	
3	068U1033	1/3	1/8	1/6	1/5	1/4	1/4	1/3	1/3	1/3	1/3	1/3	
4	068U1034	1/2	1/4	1/4	1/4	1/3	1/3	1/2	1/2	1/2	3/4	3/4	
5	068U1035	3/4	1/3	1/3	1/3	1/2	1/2	3/4	3/4	3/4	1	1	
6	068U1036	1 1/2	1/2	1/2	1/2	3/4	3/4	1	1 1/4	1 1/4	1 1/2	1 1/2	
7	068U1037	2	1/2	3/4	3/4	1	1	1 1/3	1 1/2	1 3/4	2	2	
8	068U1038	2 3/4	1	1	1 1/3	1 1/2	1 3/4	2	2 1/3	2 1/2	3	3	
9	068U1039	4	1 1/3	1 1/2	1 3/4	2	2 1/2	2 3/4	3 1/4	3 1/2	4	4 1/2	

R-404A			Evaporator temperature (°F)									
Orifice size	Danfoss Code No.	Nominal capacity of installed valve ¹ (tons)	-40	-30	-20	-10	0	10	20	30	40	50
			Rated capacity ² (tons)									
0	068U1030	1/8	1/20	1/20	1/15	1/15	1/10	1/10	1/8	1/8	1/8	1/8
1	068U1031	1/5	1/15	1/15	1/10	1/8	1/8	1/6	1/6	1/5	1/5	1/5
2	068U1032	1/4	1/15	1/15	1/10	1/8	1/6	1/5	1/5	1/4	1/4	1/4
3	068U1033	1/3	1/10	1/8	1/8	1/6	1/5	1/4	1/4	1/3	1/3	1/3
4	068U1034	1/2	1/6	1/5	1/4	1/4	1/3	1/3	1/2	1/2	1/2	1/2
5	068U1035	3/4	1/5	1/4	1/3	1/3	1/2	1/2	1/2	3/4	3/4	3/4
6	068U1036	1 1/4	1/3	1/3	1/2	1/2	3/4	3/4	1	1	1	1 1/3
7	068U1037	1 1/2	1/3	1/2	1/2	3/4	1	1	1 1/3	1 1/2	1 1/2	1 3/4
8	068U1038	2 1/3	1/2	3/4	1	1	1 1/3	1 1/2	2	2	2 1/3	2 1/2
9	068U1039	3 1/3	3/4	1	1 1/3	1 1/2	2	2 1/4	2 1/2	3	3 1/2	3 3/4

R-134a			Evaporator temperature (°F)									
Orifice size	Danfoss Code No.	Nominal capacity of installed valve ¹ (tons)	-40	-30	-20	-10	0	10	20	30	40	50
			Rated capacity ² (tons)									
0	068U1030	1/8	1/30	1/20	1/20	1/20	1/15	1/15	1/10	1/10	1/8	1/8
1	068U1031	1/6	1/20	1/15	1/15	1/10	1/10	1/8	1/8	1/6	1/6	1/5
2	068U1032	1/5	1/15	1/15	1/15	1/10	1/8	1/6	1/6	1/5	1/5	1/5
3	068U1033	1/4	1/15	1/10	1/8	1/8	1/6	1/5	1/5	1/4	1/4	1/4
4	068U1034	1/3	1/8	1/6	1/5	1/5	1/4	1/4	1/3	1/3	1/3	1/2
5	068U1035	1/2	1/5	1/5	1/4	1/4	1/3	1/3	1/2	1/2	1/2	1/2
6	068U1036	3/4	1/4	1/4	1/3	1/3	1/2	1/2	3/4	3/4	1	1
7	068U1037	1 1/4	1/3	1/3	1/2	1/2	3/4	3/4	1	1	1 1/4	1 1/2
8	068U1038	1 3/4	1/2	1/2	3/4	3/4	1	1 1/4	1 1/2	1 3/4	2	2
9	068U1039	2 1/2	3/4	1	1	1 1/3	1 1/2	1 3/4	2	2 1/3	2 3/4	3

R-448A			Evaporator temperature (°F)					
Orifice size	Danfoss Code No.	Nominal capacity of installed valve ³ (tons)	-40	-20	0	20	40	50
			Rated capacity ² (tons)					
0	068U1030	½	⅜ ₂₅	⅙ ₁₀	⅙	⅙	⅙	⅙
1	068U1031	¼	⅙ ₁₀	⅙ ₈	⅙ ₅	⅙ ₄	⅙ ₄	⅙ ₃
2	068U1032	⅓	⅙ ₈	⅙ ₆	⅙ ₅	⅙ ₄	⅙ ₃	⅙ ₃
3	068U1033	⅔ ₅	⅙ ₆	⅙ ₅	⅙ ₄	⅙ ₃	⅔ ₅	⅙ ₂
4	068U1034	¾	⅙ ₄	⅙ ₃	⅙ ₂	⅔ ₅	¾	¾
5	068U1035	1	⅙ ₃	⅙ ₂	⅔ ₅	¾	1	1
6	068U1036	1 ½	⅙ ₂	⅔ ₃	1	1 ⅙ ₅	1 ⅙ ₂	1 ⅔ ₅
7	068U1037	2	⅔ ₃	1	1 ¼	1 ⅔ ₅	2	2 ¼
8	068U1038	3	1	1 ⅙ ₃	1 ⅔ ₅	2 ⅙ ₅	3	3 ¼
9	068U1039	4	1 ⅔ ₅	1 ⅔ ₃	2 ⅔ ₅	3 ⅙ ₅	4	4 ½

R-449A			Evaporator temperature (°F)					
Orifice size	Danfoss Code No.	Nominal capacity of installed valve ³ (tons)	-40	-20	0	20	40	50
			Rated capacity ² (tons)					
0	068U1030	½	⅜ ₂₅	⅙ ₁₀	⅙	⅙	⅙	⅙
1	068U1031	¼	⅙ ₁₀	⅙ ₈	⅙ ₅	⅙ ₄	⅙ ₄	⅙ ₃
2	068U1032	⅓	⅙ ₈	⅙ ₆	⅙ ₅	⅙ ₄	⅙ ₃	⅙ ₃
3	068U1033	⅔ ₅	⅙ ₆	⅙ ₅	⅙ ₄	⅙ ₃	⅔ ₅	⅔ ₅
4	068U1034	¾	⅙ ₄	⅙ ₃	⅙ ₂	⅔ ₅	¾	¾
5	068U1035	1	⅙ ₃	⅙ ₂	⅔ ₅	¾	1	1
6	068U1036	1 ⅔ ₅	⅙ ₂	⅔ ₃	1	1 ⅙ ₅	1 ⅙ ₂	1 ⅔ ₅
7	068U1037	2	⅔ ₃	1	1 ⅙ ₅	1 ⅙ ₂	2	2 ⅙ ₅
8	068U1038	2 ⅔ ₅	1	1 ⅙ ₃	1 ⅔ ₄	2 ⅙ ₅	2 ⅔ ₅	3 ⅙ ₁₀
9	068U1039	4	1 ⅙ ₅	1 ⅔ ₃	2 ⅙ ₅	3 ⅙ ₈	4	4 ⅔ ₅

All capacity data is in accordance to ARI 750-2007 except where noted.

¹ Nominal capacity based on ARI standards: Evaporating temperature = 40 °F, Liquid temperature = 100 °F, Condensing temperature = 110 °F

² Capacity based on condensing temperature of 95 °F and a vapor free liquid temperature of 85 °F ahead of the expansion valve.

³ Condensing temperature = 100 °F

Spare Parts and Accessories

Description	Danfoss Code No.
Bulb strap	068U3507
Metal Gasket (24 pcs)	068U0015
Filter for orifices 0–4 (clear, 24 pcs)	068U1706
Filter for orifices 5–9 (blue, 24 pcs)	068U0016

Selection and Installation Instructions

1. Select Valve Body

Select the valve body based on refrigerant and need for internal or external equalization using the table on the previous page under "Select Valve Body."

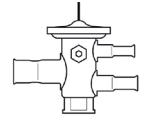

2. Select Orifice

1. Select one of ten orifices using the "Select Orifice" section on the previous page.
2. Prior to installing into system, verify that only mesh portions of the screen cover the orifice inlet.



3. Assemble Valve

1. Place one drop of refrigerant oil between the screen cage and the pushpin.
 2. Verify that the metal gasket is seated on the base of the orifice.
 3. Tighten orifice into valve (specification is 26–30 ft.-lbs.). In addition to eliminating leaks, proper torquing insures proper superheat control.
- ▶ Replace the metal washer/gasket that is mounted at the base of the orifice every time you change the orifice assembly or remove it from the valve body.

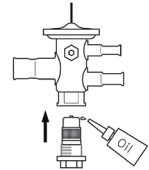

4. Braze Valve into System

1. Clean and insert copper tubing into appropriate connection on valve.
 2. Direct torch at copper tubing until it begins to color (10–15 seconds).
 3. Briefly direct torch on valve connection (2–5 seconds).
 4. Apply brazing alloy until it flows.
Do not try to fill the ridge. Attempts to do so may clog the connector.
- ▶ Sweat connections using any common brazing alloy (minimum 5% silver). As internal connector surface is copper, connections are copper to copper, and there is no need for use of high content silver solder or flux.
- ▶ **NO WET WRAP REQUIRED**
5. Secure sensing bulb with enclosed bulb strap to suction line. Bulb should be located between 1:00 & 4:00 or 8:00 & 11:00 on the tube, and the strap should be tight enough that no bulb movement is possible.
 6. Wrap included insulation tape beginning one inch before the bulb and overlapping each wrap, finishing one inch beyond the bulb on the other end.

5. Adjust Superheat

1. Remove the cap with a 5/32 inch hex key.
 2. Make superheat adjustments 1/4 turn at a time (1/4 turn ≈ 1 °F).
 - Turning clockwise increases superheat.
 - Turning counter-clockwise decreases superheat.
 3. Reinstall the cap.
- ▶ Expansion valves on low temperature systems may require minor adjustment as the factory setting is for medium temperature systems.



Easy to carry kits for truck stock

All TUA/TUAE valve bodies and orifice featured on the next page and a hex key for superheat adjustment.

068U7000

Both TUA/TUAE valve bodies and orifices and T2/TE2 and orifices plus gaskets for TUA/TUAE and a hex key for superheat adjustment.

068U7001

Kits are plastic cases with foam inserts, all valves and orifices, and instructions for selection and installation of the valves. Empty kits and foam available upon request.

TUA - Thermostatic Expansion Valves for Ice Machines

These kits are designed with contractors in mind to help save time and money by providing a universal valve that can easily be adapted to replace most OEM specific TXVs. Two kits are available, each with a valve body and a selection of three orifice sizes, copper fittings (two elbows and one reducer), a patented bulb strap, and insulation tape.



Facts

Applications:

- Ice machines
- Ice machine capacity: 75 to 2300 pounds per day
- Two kits available
- Each kit contains:
 - Exchangeable orifice thermostatic expansion valve
 - Selection of (3) orifice sizes
 - Copper fittings (2 elbows and 1 reducer)
 - Copper bulb strap
 - Insulation tape
 - Installation guide

Selection and installation instructions

1. Determine the type of machine (cube, flake, or nugget), output of the machine in pounds of ice per 24 hours, and the number of expansion devices installed.
 2. Divide the output in pounds of ice by the number of expansion valves.
 3. Use the appropriate selection table below under Technical data and ordering to determine the correct orifice size for the ice output per expansion valve.
 4. Adhere to start up and performance measurements as specified in the Instructions included with the kit.
- After the new valve is installed and the machine is back in operation, it is important to verify appropriate superheat performance. Cube ice machines typically start cycles with high superheat, which decreases as a harvest cycle approaches.

A properly sized and adjusted valve will assure adequate capacity during all phases of the freeze cycle and positive superheat through the cycle. As the valve nears the end of the freeze cycle it is imperative that you accurately measure the evaporator superheat.

1. Inspect the ice for sufficient production.
2. Inspect the suction line just before the compressor for any frost that could indicate liquid flooding.
3. Measure superheat at the end of the freeze cycle.
4. If superheat is between 10 °F and 18 °F, ice is forming appropriately, and there is no sign of liquid flooding, the installation is complete.
5. If superheat is below 10 °F, increase superheat.
6. If superheat is above 18 °F, decrease superheat.
7. If after adjusting superheat you still see too low superheat or liquid flooding, please install the next smaller orifice and repeat this process.
8. If after adjusting superheat you still see too high superheat or insufficient ice formation, please install the next larger orifice and repeat this process.

If superheat adjustment is necessary, follow these steps:

1. Remove the cap with a $\frac{5}{32}$ inch hex key.
2. Make superheat adjustments $\frac{1}{4}$ turn at a time ($\frac{1}{4}$ turn \approx 1 °F).
 - Turning clockwise increases superheat.
 - Turning counter-clockwise decreases superheat.
3. Reinstall the cap.

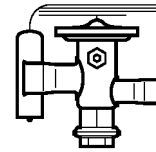

Technical data and ordering

TUA for Ice Machines

Machine Size	Estimated orifice size	lbs. of ice/24 hrs. per valve		Danfoss Code No.
		Cuber	Flaker/Nugget	
small	1	75–150	75–200	068U4900¹
	3	151–350	201–500	
	5	351–600	501–950	
large	7	601–1200	951–1650	068U4901²
	8	1201–1800	1651–2300	

Ice machine kits contain valve, (3) orifices in corresponding tables, (2) elbow fittings, (1) reducer, copper bulb strap, insulation tape, and instructions.

¹Valve in 068U4900 kit above has straightway $\frac{1}{4}$ in. \times $\frac{3}{8}$ in. ODF connections

²Valve in 068U4901 kit above has straightway $\frac{3}{8}$ in. \times $\frac{1}{2}$ in. ODF connections

Scan the QR Code for a video with more information on the TUA ice machine kits or visit <http://bit.ly/TUAicekit>



TR6 - Thermostatic Expansion Valve Kits

Danfoss TR6 kits include a valve, aeroquip, chatleff, and 3/8 inch flare fittings for evaporator connections, insulating tape, a bulb strap and instructions for easy installation in the field. All valves have a balanced port design which reduces the influence from varying condensing pressures. The valves feature a built-in check valve for heat pump applications and an anti-hunt bulb charge, optimized for residential A/C requirements.

Features TR6

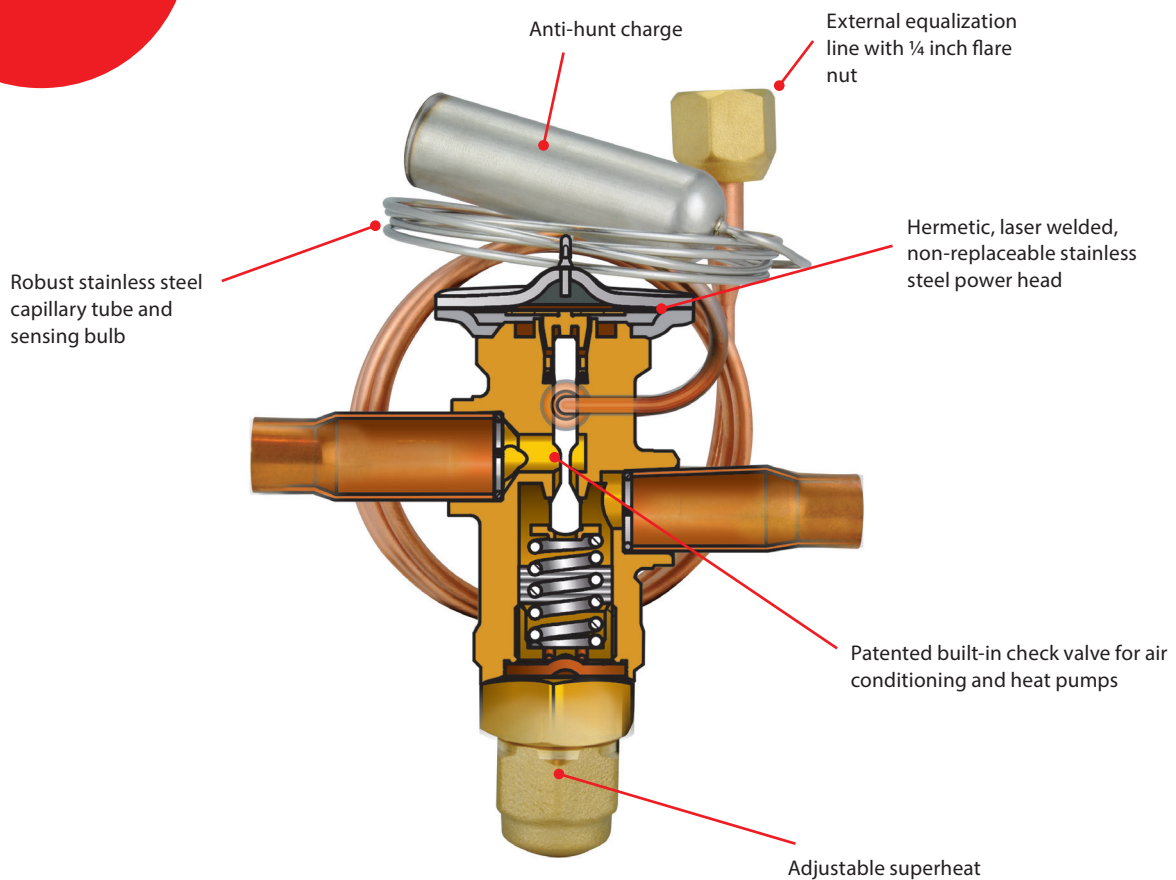

Facts

Applications:

- Residential air conditioning systems
- Rooftop units
- Heat pumps
- Light commercial air conditioning systems
- Chillers
- Split systems

- Refrigerants: R-22, R-407C, R-410A
- Capacity range: 3 to 7 Tons
- Temperature range: 15 °F to 60 °F

Kits Include:

- Thermostatic expansion valve
- Aeroquip, chatleff, 3/8 inch flare fittings
- Insulating tape
- Bulb strap
- Installation guide

Ordering

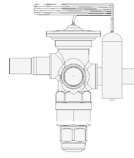

R-22 / R-407C and R-410A

Valve type	Orifice no.				Connections solder ODF		Code no. Multi pack ¹
		R410A ²	R-407C	R-22	Inlet x Outlet [in.]	Pressure equalization [in.]	
		[TR]	[TR]	[TR]			
TR6	3	–	2.8	3.1	3/8 x 3/8	1/4	067L5855
TR6	4	–	3.9	4.4	3/8 x 3/8	1/4	067L5856
TR6	5	–	4.7	5.2	3/8 x 3/8	1/4	067L5857
TR6	6	–	4.9	5.6	3/8 x 3/8	1/4	067L5858
TR6	7	–	6	6.8	3/8 x 3/8	1/4	067L5859
TR6	3	3.2	–	–	3/8 x 3/8	1/4	067L5955
TR6	4	4.5	–	–	3/8 x 3/8	1/4	067L5956
TR6	5	5.4	–	–	3/8 x 3/8	1/4	067L5957
TR6	6	5.8	–	–	3/8 x 3/8	1/4	067L5958
TR6	7	7	–	–	3/8 x 3/8	1/4	067L5959

¹ Kit part numbers consist of a valve, bulb strap, insulation tape, installation guide, and the following connectors:

- 1 Chatleff female 3/4 in. connector
- 1 Aeroquip female 5/8 in. connector
- 1 Flare 3/8 in. connector

Temperature range = -10 to 15 °C / 15 to 60 °F = 4 K / 7.2 °F
 TR6 with fixed superheat setting are available upon request.
 Single pack = 1 valve kit in a box
 Industrial pack = 12 pieces in one box

² The rated capacity is based on:

- Evaporating temperature t_e : 4.4 °C / 40 °F
- Condensing temperature t_c : 38 °C / 100 °F
- Refrigerant temperature ahead of valve t_1 : 37 °C / 98 °F



Easy to carry kits for truck stock	Danfoss Code No.
All (3) R-410A TR6 valve kit (pictured left)	067L7000
All (4) R-22/407C TR6 valve kits	067L7001

Spare Parts and Accessories

Description	Danfoss Code No.
Bulb strap	068U3507
Fitting 3/8 in. ODM x Chatleff	119F3965
Fitting 3/8 in. ODM x Aeroquip	119F3966

Scan the QR Code for a video with more information on TR6 valve features or visit <http://bit.ly/TR6Features>



TGE - Thermostatic Expansion Valves

Danfoss TGE thermostatic expansion valves are designed for commercial air conditioning and refrigeration. They feature a balanced port design which reduces the influence from varying condensing pressures. The air conditioning valves in this catalog feature an anti-hunt charge optimized for A/C applications and the refrigeration valves are designed for stable operation across a wide temperature range.

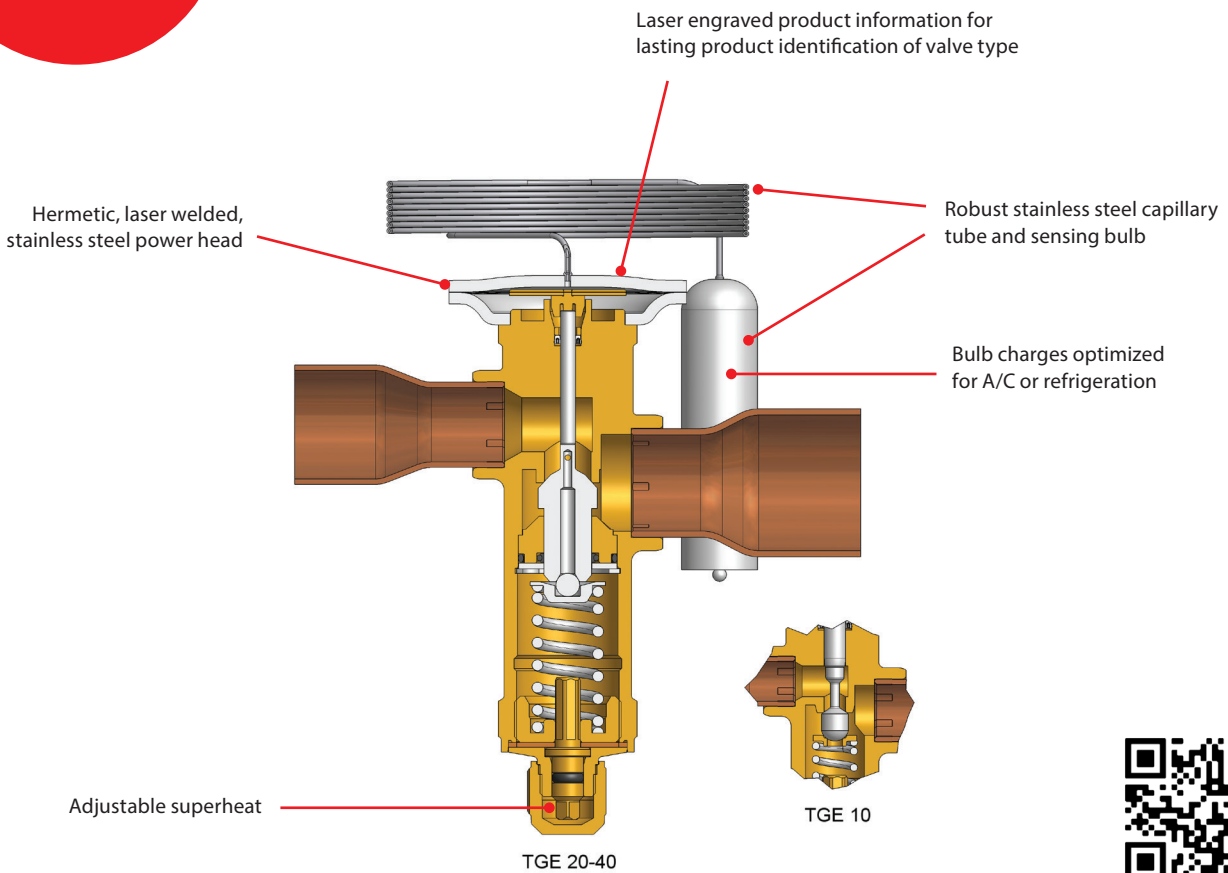
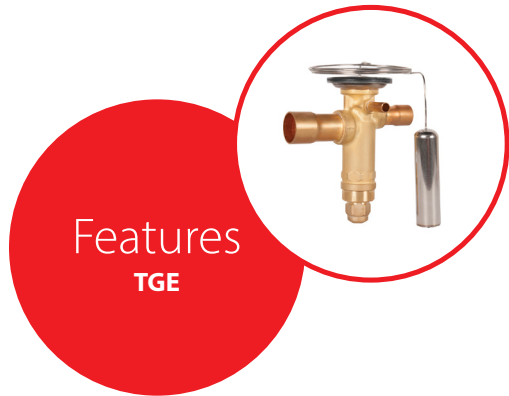

Scan the QR Code for a step-by-step set up video

Facts

Applications:

- Traditional refrigeration
- Residential air conditioning systems
- Rooftops
- Commercial air conditioning systems
- Chillers

- Refrigerants: R-22, R-407C, R-410A, R-404A, R-507A, R-134a
- Capacity range: 9 to 46 tons (varies by refrigerant)

- Temperature range:
 - Refrigeration Valves: -40 °F to +50 °F
 - Air Conditioning Valves: -22 °F to +60 °F
- Balanced port

Technical data and ordering

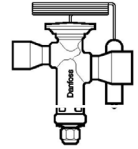

TGE

Danfoss Type	Competitor Model Numbers	Nominal capacity (tons) ³	Solder ODF connection (in.)	Danfoss Code No.
R-22, MAH charge¹		R-407C, MAH charge¹		
TGEX 10	SVE-5, EVRE-5	6	½ × ⅝	067N9403
TGEX 10	SVE-5, EVRE-5	6	½ × ⅞	067N9404
TGEX 10	SVE-6, EVRE-6	7 ½	⅝ × ⅞	067N9406
TGEX 10	SVE-6, EVRE-6	7 ½	⅝ × 1 ⅜	067N9483
TGEX 10	SVE-8, SVE-10, EBSVE 8, EVRE 8, EVRE 10	11	⅝ × ⅞	067N9407
TGEX 20	EBSVE 11, EVRE 12	12	⅝ × ⅞	067N9409
TGEX 20	EBSVE15, OVE 15	15	⅝ × 1 ⅜	067N9411
TGEX 20	EBSVE15, OVE 15	15	⅞ × 1 ⅜	067N9412
TGEX 20		18	⅞ × 1 ⅜	067N9413
TGEX 40	EBSVE 20, OVE 20	26	⅞ × 1 ⅜	067N9415
TGEX 40	OVE 30	30	1 ⅜ × 1 ⅜	067N9418
TGEX 40	OVE 40	38	2 ⅜ × 1 ⅜	067N9419
R-410A, MAH charge¹				
TGEL 10	ERZE-8	9	⅝ × ⅞	067N9206
TGEL 10	ERZE-12.5	13	⅝ × ⅞	067N9207
TGEL 20	ERZE-15	15	⅝ × ⅞	067N9209
TGEL 20	ERZE-15	15	⅝ × 1 ⅜	067N9210
TGEL 20	OZE-20	23	⅞ × 1 ⅜	067N9213
TGEL 20	OZE-20	23	1 ⅜ × 1 ⅜	067N9284
TGEL 40	OZE-25	31	⅞ × 1 ⅜	067N9285
TGEL 40	OZE-25	31	⅞ × 1 ⅜	067N9215
TGEL 40	OZE-35	35	1 ⅜ × 1 ⅜	067N9218
TGEL 40		46	1 ⅜ × 1 ⅜	067N9219
R-134a, N charge²				
TGEN 10	SJE-5, SJE-6, EBSJE-5	7	⅝ × 1 ⅜	067N5158
TGEN 20	EBSJE-7	8	⅝ × ⅞	067N5159
TGEN 20	EBSJE-12, OJE-12	12	⅞ × 1 ⅜	067N5163
TGEN 40	OJE-16	17	1 ⅜ × 1 ⅜	067N5254
TGEN 40		20	1 ⅜ × 1 ⅜	067N5255
TGEN 40	OJE-23	25	1 ⅜ × 1 ⅜	067N5169
R-404A, N charge²		R-507A, N charge²		
TGES 10	SSE-3	4	½ × ⅞	067N6151
TGES 10	SSE-4	5	½ × ⅞	067N6166
TGES 10	SSE-4	5	⅝ × ⅞	067N6150
TGES 10	SSE-6, SSE-7, EBSSE-6	7 ½	⅝ × ⅞	067N6154
TGES 20	EBSSE-7.5	9	⅝ × ⅞	067N6158
TGES 20	EBSSE-10, OSE-9	11	⅝ × ⅞	067N6188
TGES 20	EBSSE-10, OSE-9	11	⅝ × 1 ⅜	067N6155
TGES 20	EBSSE-10, OSE-9	11	⅞ × 1 ⅜	067N6181
TGES 20	EBSSE-13, OSE-12	13	⅞ × 1 ⅜	067N6162
TGES 20	OSE-21	21	1 ⅜ × 1 ⅜	067N6186

¹MAH charge: -22 °F to 60 °F, Maximum operating temperature = 300 °F

²N charge: -40 °F to 50 °F, Maximum operating temperature = 210 °F

³Nominal capacity based on ARI standard: Evaporating temperature = 40 °F, Liquid temperature = 100 °F, Condensing temperature = 110 °F

Spare Parts and Accessories

Description	Danfoss Code No.
Bulb strap	067N0557

ERC 213 - Electronic Temperature Control

The ERC 213 is designed to meet the needs of today's refrigeration technician. Its universal fit, easy setup, and capacity to work with any common temperature sensor make it the obvious choice when replacing an electronic temperature control.



Compatible with all common temperature sensors

Kitted with two temperature sensors



Easy to install (attachment clips included)

Quick five-step set up process

Technical data and ordering

ERC 213

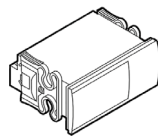

Voltage	Applications	Danfoss Code No.
115V 50/60 Hz	Compressor or solenoid for pump down, defrost, and fan	080G3467
220V 50/60 Hz		080G3469



Scan the QR Code for a step-by-step set up video or visit http://bit.ly/ERC213_video

Facts

Applications:

- Traditional refrigeration
- Walk-ins
- Chillers

Controls:

- defrost
- fan
- compressor/solenoid for pump down

Temperature range:

- operating conditions: 14 °F to 131 °F
- storage conditions: -40 °F to 158 °F

4 inputs:

- 2 analog
- 1 analog/digital
- 1 digital

KoolConnect Bluetooth Enabler and App

Save time on equipment programming in the production line, and during on-site service. Simply connect to the electronic controls via Bluetooth to read-out historic data, adjust, download, and upload parameter settings, and look up alarm and error status. All from the convenience of your mobile phone.



Plug-and-play on-site connectivity



Easy commissioning and service



Seamless parameter configuration



Mass programming



Immediate report sharing



Model	Description	Code no. single pack	Code no. industrial pack (60 pcs)
EKA 202	BLE adapter without power backup	080N0022	080N0026
EKA 203	BLE adapter with power backup	080N0023	080N0027

Model	Description
Interface cable – ERC 11X series	080N0329
Interface cable – ERC 21X series	080N0327
Interface cable – EETa	080N0325



Scan here to download the app

KPU 19 - Thermostats

The KPU 19 thermostats are designed for easy installation and service with bottom and rear knockouts, differential adjustment dial, a tamper-resistant design, and a robust thermoplastic housing.

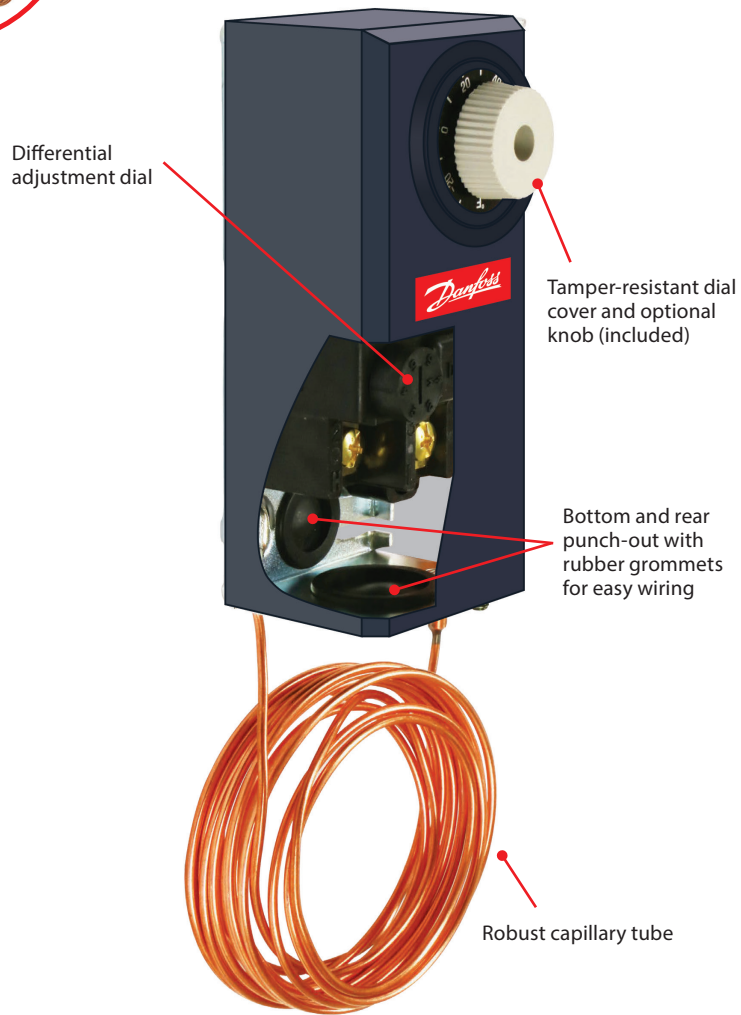
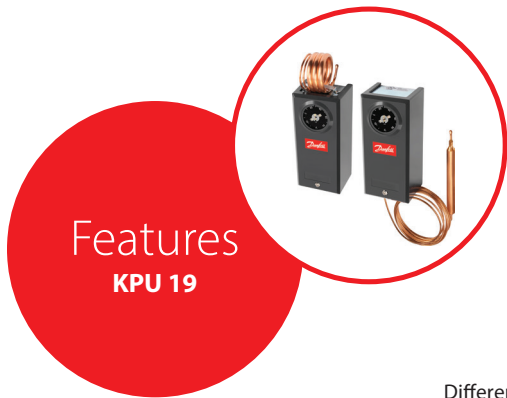

Facts

Applications:

- Traditional refrigeration
- Air conditioning
- Ventilating systems
- Heating systems
- Ambient temperature: -30 °F to +158 °F (bulb sensor); -30 °F to +140 °F (room sensor)
- Switch: Single pole changeover switch (SPDT) and single pole non-changeover switch (SPST)
- Enclosure: NEMA 1
- Cable entry: 7/8 inch cable entry for 1/2 inch male pipe thread connection (conduit boss) or similar screwed cable entry

Technical data and ordering



KPU 19 Thermostats

KPU Series	Bulb type	Range (°F)	Contact/Reset	Capillary tube length (in.)	Maximum bulb temperature (°F)	Competitor part no.	Danfoss Type	Danfoss Code No.
KPU 19	Remote bulb	-30 to 80	SPDT/Auto	120	140	A19ABC-24C A19ABC-37C A19ABC-74C A19AAC-4C A19AAF-20C	KPU19	060L2150 ¹
KPU 19		-30 to 80	SPST/Auto	80	140	A19AAD-5C A19ABA-40C A19AAD-12C	KPU19	060L2151 ¹
KPU 19	Room bulb	-30 to 80	SPDT/Auto	Room sensor	140	A19BBC-2C A19BAB-3C A19BAC-1C A19BAF-1C	KPU19	060L2152

¹ As 060L1250 is SPDT, 060L2150 can replace competitor parts crossed to both 060L2150 and 060L2151.

Contact Load	Resistive load		0.5~16A/120V AC 0.5~8A/240V AC
	Inductive load	Full load	0.5~16A/120V AC 0.5~8A/240V AC
		Locked rotor	96A/120V AC 48A/240V AC
	Pilot duty		125VA/240V DC



Scan the QR Code for a video of a KPU 19 temperature control replacement or visit http://bit.ly/KPU19_video

KPU 60/70 - Thermostats

KPU 60/70 thermostats are designed to be technician-friendly by functioning as easy and direct replacements for most controls on the market and feature snap-action switches, highly visible contrast scales, fingertip contact testing, and are easily adjustable using a standard refrigeration wrench.



Easy adjustment of temperature setting with hand knob (all but models with manual reset). Differential setting adjusted with standard refrigeration wrench. A set screw prevents settings from migrating.

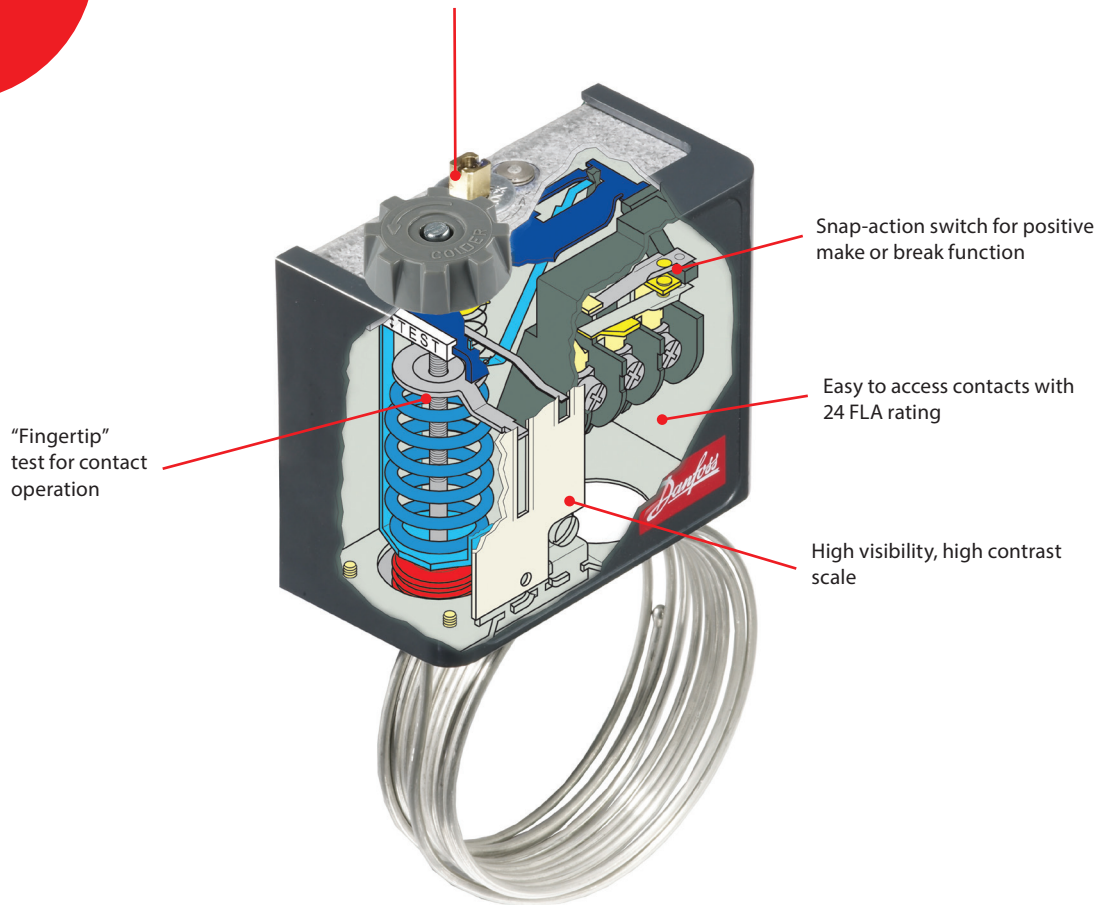

"Fingertip" test for contact operation

Snap-action switch for positive make or break function

Easy to access contacts with 24 FLA rating

High visibility, high contrast scale

Facts

Applications:

- Traditional refrigeration
- Air conditioning
- Ventilating systems
- Heating systems
- Ambient temperature: -40 °F to +122 °F (175 °F for maximum 2 hours)
- Switch: Single pole double throw (SPDT)
- Enclosure: NEMA 1
- Cable entry: 7/8 inch cable entry for 1/2 inch male pipe thread connection (conduit boss) or similar screwed cable entry

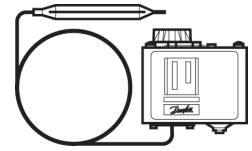

Technical data and ordering

KPU 60/70 Thermostats

Danfoss Type	Bulb type	Range (°F)	Contact/Reset	Capillary tube length (in.)	Differential		Maximum bulb temperature (°F)	Competitor part no.	Danfoss Code No.
					at lowest temp. setting	at highest temp. setting			
KPU 61	Straight capillary tube ¹	-20 to 60	SPDT/Auto	80	10 to 40	2.5 to 13	250	O10-1416 O10-1010 O16-111 O10-1419	060L5201
KPU 61	Remote air coil ¹	-20 to 60	SPDT/Auto	80	10 to 40	2.5 to 13	250	O10-1408 O10-1409 O10-1473 O16-104 O10-1410	060L5203
KPU 62	Room sensor ¹	-20 to 60	SPDT/Auto	Room sensor	10 to 40	2.5 to 13	250	O10-1072 O10-1418 O16-594 O60-101	060L5206
KPU 68	Room sensor ¹	25 to 95	SPDT/Auto	Room sensor	8 to 45	3 to 13	250	O10-1802 O16-595 O10-301 O16-165	060L5215
KPU 73	Remote bulb ²	-15 to 60	SPDT/Auto	80	6.5 to 32	5 to 50	175	O60-100 O60-120	060L5208
KPU 71	Remote bulb ²	25 to 70	SPDT/Auto	80	5.5 to 18	4 to 16	175		060L5218
KPU 77	Remote bulb ²	60 to 140	SPDT/Auto	80	6 to 18	6.3 to 18	265	O60-200 A19AAF-12C A19AAB-4C A19ABB-2C A19ABB-7C	060L5223

¹ Bulb must be installed in colder position than thermostat housing and capillary tube.

² Temperature variations in excess of 70 °F between sensing bulb, housing, and capillary tube will influence scale accuracy.

Contact Load	Resistive load		24A/120V AC 24A/240V AC
	Inductive load	Full load	24A/120V AC 24A/240V AC
		Locked rotor	144A/120V AC 144A/240V AC
	Pilot duty		12W/120V DC



Scan the QR Code for a video of a KPU 60/70 temperature control replacement or visit http://bit.ly/KPU6070_video

KPU - Pressure Switches

KPU pressure switches are designed to be contractor friendly and used in refrigeration and air-conditioning systems to protect the systems from excessively low suction or high discharge pressure. They can also be applied to start and stop compressors and the fans of air-cooled condensers. KPU pressure switches, in single and dual versions, cover a comprehensive range of applications and are designed for use with fluorinated and non-aggressive refrigerants. Most KPU pressure controls can be used with R-410a systems with only a few code numbers.

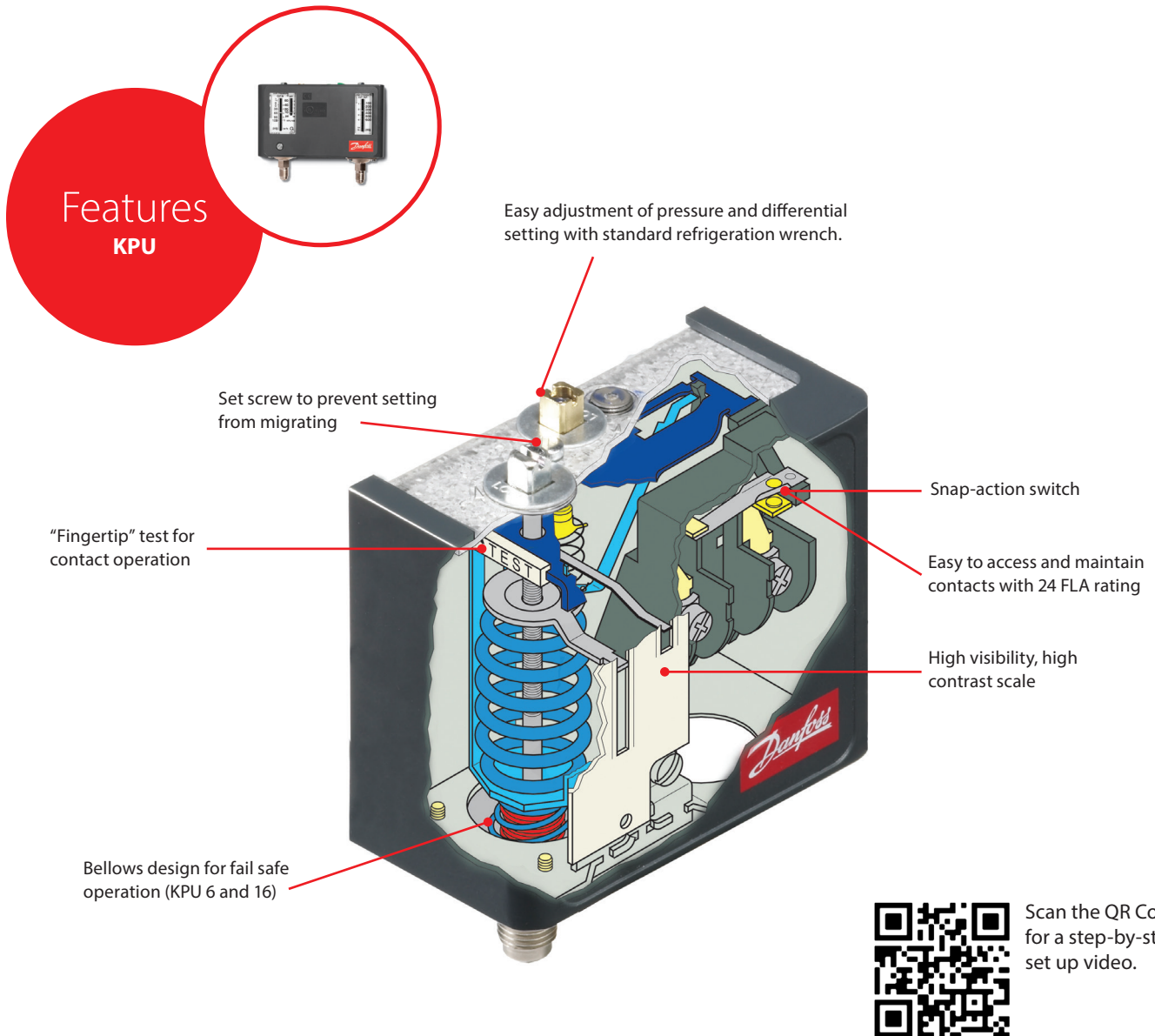

Facts

Applications:

- Commercial air conditioning
- Commercial refrigeration
- Supermarket Refrigeration
- Food processing and storage
- Product Types
 - Low Pressure
 - High Pressure
 - Dual Pressure
- Maximum working/test pressure
 - LP controls: 245/290 psig
 - HP controls: 505/505 psig
 - KPU 6 and 16 on HP side: 675/675 psig
- Refrigerants: R-22, R-134a, R-404A, R-407A, R-407C, R-407F, R-422B, R-422D, R-438A, R-448A, R-449A, R-450A, R-452A, R-507A, R-513A, R-410A (only KPU 1, 2, 6, 16)
- Ambient temperature: -40 to +150 °F (175 °F for max. 2 hours)
- Enclosure: NEMA 1
- Cable entry: 3/8 inch cable entry for 1/2 inch male pipe thread connection (conduit boss) or similar screwed cable entry
- Pressure connection: 1/4 inch M flare or 3/16 inch capillary tube with 1/4 inch flare nut
- KPU 6W, 6B, and 16B feature "dual bellows" on high pressure side to prevent leaks in the case of a bellows rupture

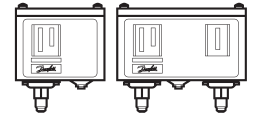

Technical data and ordering

KPU Pressure Switches

Danfoss Type	Pressure	Reset	Contact system	Range (in. Hg/psig)	Differential (psig)	Max. working pressure (psig)	Competitor part no. ¹	Danfoss Code No.	
								¼ in. M flare	36 in. capillary tubes with ¼ in. flare nuts
KPU 1	Low	Automatic	SPDT	6 to 108	10 to 60	250	O10-1483 P70AB-2C	060-5231	060-5233
KPU 2	Low	Automatic	SPST (NO)	6 to 73	6 to 30	250	O10-1402 P70AB-12C P170AB-12C	060-5237	060-5235
KPU 2	Low	Automatic	SPDT	6 to 73	6 to 30	250		060-5239	060-5240
KPU1B	Low	Manual	SPDT	28 to 100	10.2	250		060-5232	060-5234
KPU 5	Fan cycling	Automatic	SPST (NO)	100 to 465	25 to 85	510	O10-2054 P70AA-118C	060-5241	060-5242
KPU 6W ²	High	Automatic	SPDT	100 to 600	58 to 145	675	O16-108 P170CA-400C P70CA-3C	060-5243	060-5245
KPU 6B ²	High	Manual	SPDT	100 to 600	60	675	P70DA-1C	060-5244	060-5246

KPU Dual Pressure Switches

Danfoss Type	Low pressure side		High pressure side		Rest		Contact system (LP/HP)	Max. working pressure (low/high side) (psig)	Competitor part no. ¹	Danfoss Code No.	
	Range (in. Hg/psig)	Differential (psig)	Range (psig)	Differential (psig)	Low pressure side	High pressure side				¼ in. M flare	36 in. capillary tubes with ¼ flare nuts
KPU 15	6 to 108	10 to 60	100 to 465	60	Automatic	Automatic	SPST (NO/NC)	250/510	O12-1549 P170LB-1C	060-5247	060-5248
KPU 15B	6 to 108	10 to 60	100 to 465		Automatic	Manual	SPST (NO/NC)	250/510	P70LB-1C P70MA-1C	060-5249	060-5250
KPU 16B	6 to 108	10 to 60	100 to 600		Convertible ³	Convertible ³	SPDT/ SPST (NO)	250/675	O12-4834 P170LB-1C P70LB-1C P70MA-1C	060-5253	060-5254

¹ Competitor part no. equipped with capillary tube for all but P170LB-1C which has flare connections.

² KPU 6 and the high pressure side of KPU 16 are designed with fail-safe double bellows.

³ Convertible reset controls can be adjusted for either automatic or manual reset. Adjust reset setting to match product being replaced.

All controls are supplied with universal mounting bracket and mounting screws.

Ambient temperature: -40 °F to +122 °F (175 °F for maximum 2 hours).

KPU 1, 2, 6, 16 suitable for all HFC refrigerants, including R-410A.

	120/240 VAC
Alternating Current	
Motor Full Load Amps (FLA)	24
Locked Rotor Amps (LRA)	144
Direct Current	240 V DC: 12W pilot duty

Spare Parts and Accessories

Description	Type(s) applied to	Danfoss Code No.
Capillary tube; 39 in. with ¼ in. flare coupling nuts on each end	KPU with ¼ in. M flare	060-017166

MP - Differential Pressure Switch / Lube Oil Protection Switch

MP 54 and MP 55 oil differential pressure switches are used to protect refrigeration compressors against low oil pressure. These switches are compatible with HCFC and non-flammable HFC refrigerants.

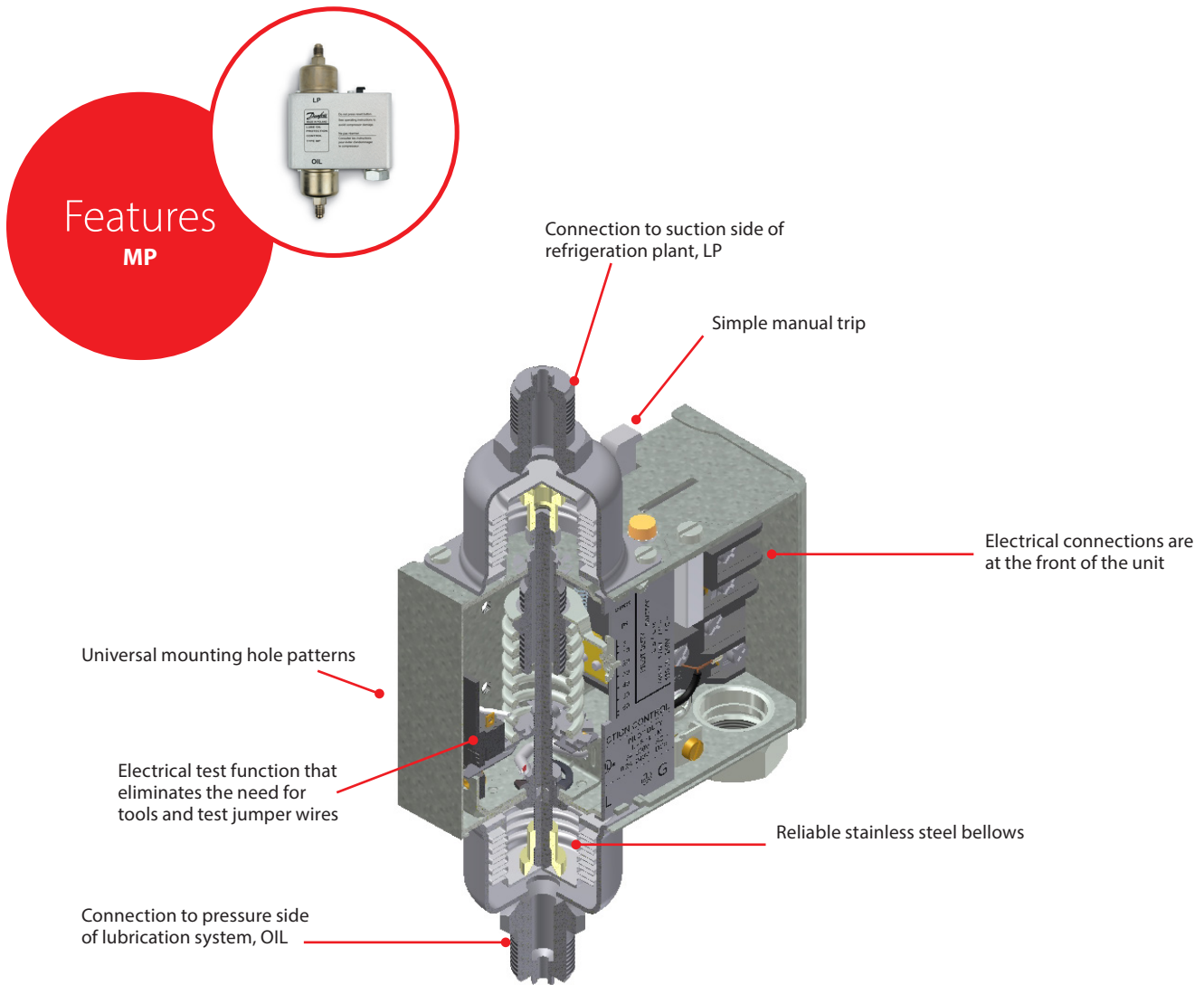

Facts

Applications:

- Commercial refrigeration
- Commercial air conditioning
- Supermarket Refrigeration
- Food processing and storage

- Product Types
 - Fixed Differential (MP 54)
 - Adjustable Differential (MP 55)
- Refrigerants: HCFC and non-flammable HFC refrigerants
- Max working/test pressure: 245 psig/320 psig
- Ambient temperature: The time relay is temperature-compensated in the range -40 °F to +140 °F
- Enclosure: ~NEMA 1
- Cable entry: Integral ½ inch female NPSM swivel cable connector for ½ inch male pipe thread connector.
- Pressure connection: ¼ inch M flare or 36 inch capillary tube with ¼ inch flare nut

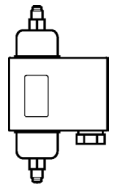

Technical data and ordering

MP - Differential Pressure Control / Lube Oil Protection Control

Danfoss Type	Control differential Δp (psig)	LP side Regulation range (in. Hg/psig)	Time relay delay time seconds	Competitor Code Nos.	Danfoss Code No.	Competitor Code Nos.	Danfoss Code No.
				¼ in. M flare		36 in. capillary tubes with ¼ in. flare nuts	
MP54	6	to 175	45	P145NCA/B-82C	060B200891	P45NCA-82C 3321-009	060B205091
	9	29 to 175	90	3321-001	060B200266		
	9	to 175	120	P145NCA/B-12C P31-5827 3321-001	060B200391 ²	P45NCA-12C P30-5826 3321-010	060B205391 ²
MP55	4.3 to 65	29 to 175	45			P288AA-18/2C P30-3601 3321-014/5 ³	060B205491
	4.3 to 65	to 175	60	P128AA-2C	060B201291 ¹		
	4.3 to 65	29 to 175	120	P128AA-17C	060B200791	P28AA-17C P28NA-5C P30-3801 3321-014/5 ³	060B205791

¹ With glow lamp that remains on during normal operation of compressor.

Note: When time delay is energized which also means that min. permissible oil pressure (differential Δp) is reached, light goes out.

² Three-wire hook-up with jumper that is provided in the box with control.

³ The 3321 series controls feature adjustable delay and fixed differential. The differential for 3321-014 controls is set at 15 psig and 3321-015 is at 30 psig. Select control with appropriate delay time.

Spare Parts and Accessories

Description	Type(s) applied to	Danfoss Code No.
Capillary tube; 39 in. with ¼ in. flare coupling nuts on each end	MP with ¼ in. M flare	060-017166

EVR Version 2 - Solenoid Valves

EVR Version 2 solenoid valves are direct or servo-operated solenoid valves for liquid, suction, and hot gas lines. They are suitable for all refrigeration, freezing, and air conditioning applications and are compatible with fluorinated refrigerants. The valves can be delivered as normally open or closed as well as with or without manual operation.

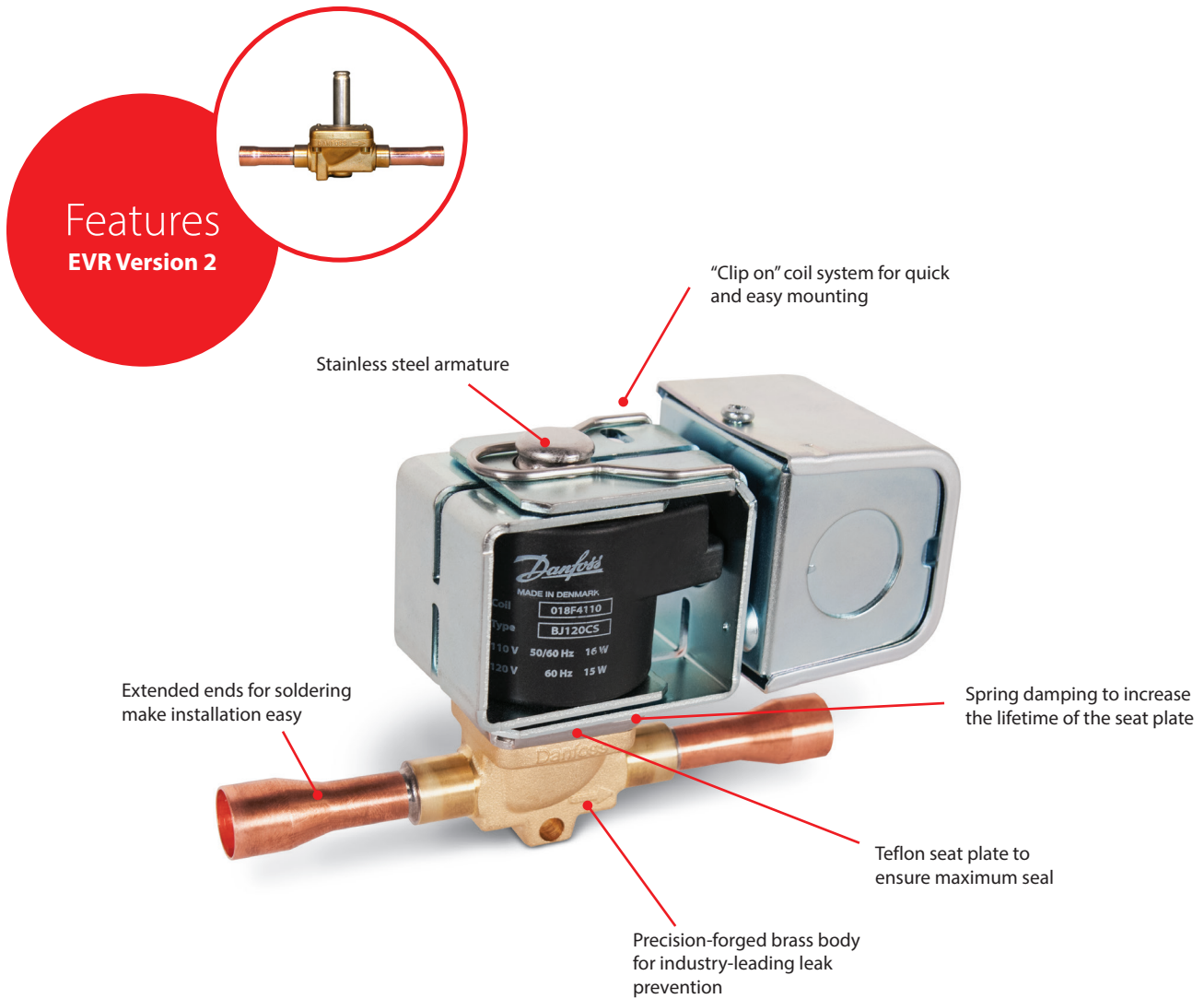

Facts

Applications:

- Commercial refrigeration
- Freezers
- Air conditioning units
- Commercial refrigeration
- Supermarket Refrigeration
- Refrigerants: Use with any fluorinated refrigerant
- Maximum working pressure:
 - EVR 2–EVR 8: 655 psig
 - EVR 10: 655 psig
 - EVR 15–EVR 40: 655 psig
- Temperature range: -40 °F to +220 °F
- Connections:
 - Flare connections up to 5/8 inch
 - Solder connections up to 2 1/8 inch
- Available in normally open and normally closed
- Available with or without manual stem
- Coil available with junction box (NEMA 2) and conduit boss (NEMA 4)

Technical data and ordering

EVR Version 2 Solenoid valves

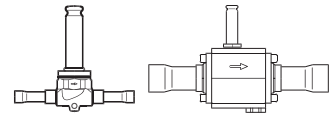

Danfoss Type	Rated capacity (liquid tons)			Solder ODF connection (in.)	Port size (in.)	Max. working pressure (psig)	Danfoss Code No. ¹	
	R-22	R-134a	R-404A				with manual stem	without manual stem
	R-407C		R-507A					
EVR 3	1.66	1.54	1.07	¼	⅜	655		032F1206
EVR 3	1.66	1.54	1.07	⅜	⅜	655		032F1204
EVR 6	5.47	5.07	3.51	⅜	15/64	655	032L7116	032L1212
EVR 6	5.47	5.07	3.51	½	15/64	655	032L7144	032L1209
EVR 8	6.52	6.03	4.18	½	5/16	655	032L7148	032L7121
EVR 10	11.50	10.64	7.38	5/8	3/8	655	032L7149	032L1214
EVR 15	17.71	16.39	11.37	5/8	9/16	655		032L1228
EVR 18	23.18	21.46	14.88	7/8	19/32	655	032L1004	
EVR 20	36.76	34.04	23.60	7/8	7/8	655	032L1254	032L1240
EVR 22	41.93	38.82	26.92	1 1/8	15/16	655	032L7137	032L7145
EVR 25	60.19	55.72	38.64	1 3/8	1	655	032L2207	032L2208
EVR 32	102.85	95.23	66.03	1 5/8	7/8	655	032L1103	032L1104

¹ Valve body is normally closed (NC) and excludes coil. Additional code nos. available in Coolselector or contact Danfoss.

Coils for Solenoid Valves



Voltage (V)	Frequency (Hz)	Power consumption (W)	Danfoss Type (junction box) ²	Length of wire (in.)	Danfoss Code no.	Danfoss Type (conduit boss) ³	Length of wire (in.)	Danfoss Code No.
24	50/60	14	BJ024CS	7	018F4100	BX024CS	18	018F4102
110	50/60	16	BJ120CS	7	018F4110	BX120CS	18	018F4112
120	60	15						
208-240	60	14	BJ240CS	7	018F4120	BX240CS	18	018F4122
230	50	17						

² Enclosure rating for BJ coils is NEMA 2 ~ IP 12-32

³ Enclosure rating for BX coils is NEMA 4 ~ IP 54

Dual Voltage/Dual Frequency Coil



Coil Type	Voltage (V)	Frequency (Hz)	Power consumption (W)	Danfoss Type (junction box) ⁴	Length of wire (in.)	Danfoss Code no.	Danfoss Type (conduit boss) ⁵	Length of wire (in.)	Danfoss Code No.
EVR	110	50	12	BT240CS	7	018F4180	BU240CS	7	018F4181
	110-120	60							
	230	50							
	208-240	60							

⁴ Enclosure rating for BT coils is NEMA 2 ~ IP 12-32

⁵ Enclosure rating for BU coils is NEMA 4 ~ IP 54

Spare Parts and Accessories

Description	Version(s) applied to	Type(s) applied to	Danfoss Code No.
Permanent magnet coil for servicing and testing	1, 2	all	018F0091
Service kit (NC); O-ring, (4) screws, armature assembly, rubber gasket, compression spring	1, 2	EVR 3	032F0181
Seal kit (NC); O-ring for armature tube, rubber gasket, O-ring for steel cover, support ring	1	EVR 6, 8	032F8165
Service kit (NC); diaphragm assembly, O-ring for armature tube, (4) screws T20, (4) screws T15, armature assembly, rubber gasket, O-ring for steel cover, support ring, compression spring	1	EVR 6, 8	032F8166
Seal kit (NC/NO); O-ring for armature tube, rubber gasket, support ring	2	EVR 6, 8	032L0548
Service kit (NC); diaphragm assembly, O-ring, (4) screws, armature assembly, rubber gasket, support ring, compression ring	2	EVR 6, 8	032L0550
Service kit (NC); diaphragm assembly, O-ring, (4) screws, armature assembly, rubber gasket, compression spring	1	EVR 10	032F0185
Service kit (NC); diaphragm assembly, O-ring, (4) screws, armature assembly, rubber gasket, compression spring	2	EVR 10	032L0552
Seal kit (NC/NO); O-ring for armature tube, (3) rubber gasket (1 ea. for EVR 10, 15, 20) (4) refrigeration gasket (2 ea. For EVR 15, 20)	1, 2	EVR 10, 15, 20	032F8196
Service kit (NC); diaphragm assembly, O-ring, (4) screws, armature assembly, rubber gasket, (2) refrigeration gasket (flange connections), compression spring	2	EVR 15, 18, 20, 22	032L0554
Service kit (NC); diaphragm assembly, O-ring, (4) screws, armature assembly, rubber gasket, refrigeration gasket, compression spring	1	EVR 15, 18	032F0187
Service kit (NC); diaphragm assembly, O-ring, (4) screws, armature assembly, rubber gasket, refrigeration gasket, compression spring	1	EVR 20, 22	032F0189
Manual spindle; spindle assembly	1	EVR 20, 22	032F0193
Seal kit (NC); (2) Al. gasket, (3) O-rings, rubber gasket	1, 2	EVR 25	032F2326
Piston service kit (NC); (2) O-ring, compression spring, piston assembly, insert block, rubber gasket, piston ring	1, 2	EVR 25	032F2326
Piston service kit (NC); (5) O-rings, Al. gasket, piston assembly, insert block, piston ring, compression spring, refrigeration gasket	1, 2	EVR 32	042H0172
Pilot service kit (NC); (2) Al. gaskets, O-ring, orifice, armature tube, armature assembly, compression spring	1, 2	EVR 25, 32	042H0165
Seal kit (NC); (4) O-rings, (2) Al. gaskets	1, 2	EVR 32	032F2327

To determine the version of EVR, read the code number engraved on the armature. Codes beginning with 032F, 032G and 042H are V1; codes beginning with 032L are V2. Kits for types not included in catalog may be available; contact Danfoss for more information.

KVP/KVL/KVR/NRD/KVC/CPCE - Pressure Regulators

Danfoss has a variety of pressure regulators to control the low and high pressure sides and efficient function of a refrigeration system under varying load conditions.

Pressure regulators include:

- Evaporator Pressure Regulator (KVP)
- Crankcase Pressure Regulator (KVL)
- Condensing Pressure Regulator (KVR)
- Differential Pressure Regulator (NRD)
- Hot Gas Bypass Valves (KVC/CPCE)

KVP/KVL/KVR/
NRD/KVC/CPCE

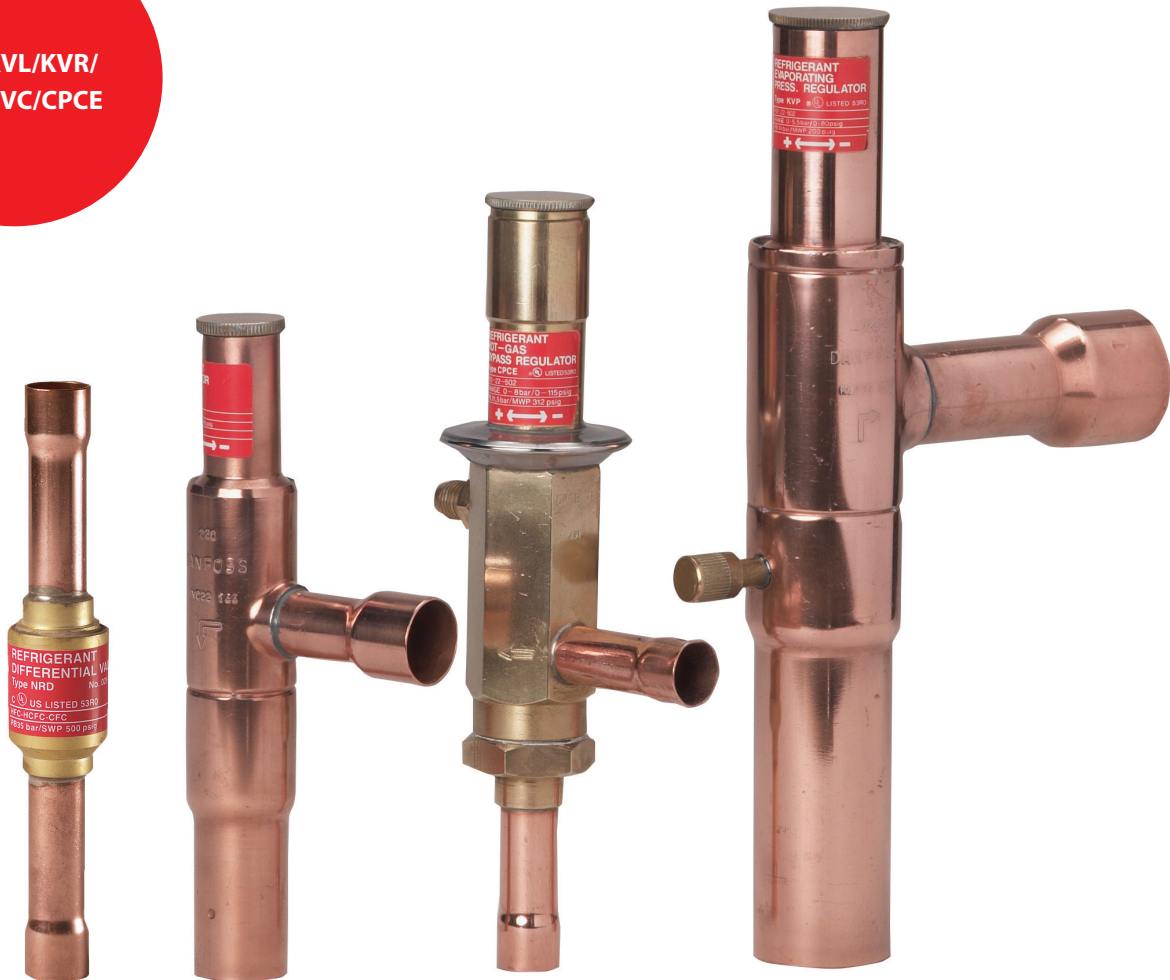

Facts

- All valves available for use with any CFC, HCFC, or HFC refrigerant, except R-410A
- Very stable and accurate pressure regulation
- Hermetic brazed construction 100% leak tested
- Available with flare and ODF solder connections
- Stainless steel bellows for extended lifetime
- Built-in valve seat dampening design
- Pressure regulation side
 - KVP/KVR—opens on a rise in pressure
 - KVC/KVL—opens on a fall in pressure

Technical data and ordering

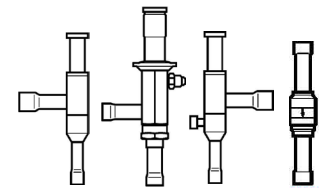

KVP/KVL/KVR/NRD/KVC/CPCE - Pressure Regulators

Application	Danfoss Type	Rated capacity (tons)				Solder ODF connection (in.)	Setting range (psig)	Factory setting (psig)	Maximum working pressure (psig)	Maximum test pressure (psig)	Minimum temp. of medium (°F)	Maximum temp of medium (°F)	Danfoss Code No.
		R-22	R-134a	R-404A	R-407C								
Evaporating Pressure Regulator	KVP 12	1.30	0.90	1.20	1.20	½	0 to 80	29	260	286	-50	265	034L0023
	KVP 15	1.30	0.90	1.20	1.20	¾	0 to 80	29	260	286	-50	265	034L0029
	KVP 22	1.30	0.90	1.20	1.20	¾	0 to 80	29	260	286	-50	265	034L0025
	KVP 28	2.80	1.90	2.40	2.60	1 ½	0 to 80	29	260	286	-50	265	034L0026
	KVP 35	2.80	1.90	2.40	2.60	1 ¾	0 to 80	29	260	286	-50	265	034L0032
Crankcase Pressure Regulator	KVL 12	1.20	0.80	1.00	1.10	½	3 to 87	29	260	286	-75	266	034L0043
	KVL 15	1.20	0.80	1.00	1.10	¾	3 to 87	29	260	286	-75	266	034L0049
	KVL 22	1.20	0.80	1.00	1.10	¾	3 to 87	29	260	286	-75	266	034L0045
	KVL 28	4.10	2.60	3.40	3.80	1 ½	3 to 87	29	260	286	-75	266	034L0046
	KVL 35	4.10	2.60	3.40	3.80	1 ¾	3 to 87	29	260	286	-75	266	034L0052
Condensing Pressure Regulator	KVR 12	Liquid: 12.70 Hot gas: 4.13	Liquid: 11.80 Hot gas: 3.03	Liquid: 8.20 Hot gas: 3.27	Liquid: 13.80 Hot gas: 4.50	½	73 to 254	145	406	450	-50	266	034L0093
	KVR 15	Liquid: 12.70 Hot gas: 4.13	Liquid: 11.80 Hot gas: 3.03	Liquid: 8.20 Hot gas: 3.27	Liquid: 13.80 Hot gas: 4.50	¾	73 to 254	145	406	450	-50	266	034L0097
	KVR 22	Liquid: 12.70 Hot gas: 4.13	Liquid: 11.80 Hot gas: 3.03	Liquid: 8.20 Hot gas: 3.27	Liquid: 13.80 Hot gas: 4.50	¾	73 to 254	145	406	450	-50	266	034L0094
	KVR 28	Liquid: 32.60 Hot gas: 10.93	Liquid: 30.20 Hot gas: 8.04	Liquid: 20.90 Hot gas: 8.66	Liquid: 35.50 Hot gas: 11.91	1 ½	73 to 254	145	406	450	-50	266	034L0095
	KVR 35	Liquid: 32.60 Hot gas: 10.93	Liquid: 30.20 Hot gas: 8.04	Liquid: 20.90 Hot gas: 8.66	Liquid: 35.50 Hot gas: 11.91	1 ¾	73 to 254	145	406	450	-50	266	034L0100
Differential Pressure Regulator	NRD 12s ¹					½	73 to 254	145	667	870	-50	266	020B1132
Hot Gas Bypass	KVC 12	2.14	1.36	2.02	2.31	½	3 to 87	29	406	450	-50	266	034L0143
	KVC 15	4.17	2.65	3.93	4.50	¾	3 to 87	29	406	450	-50	266	034L0147
	KVC 22	5.35	3.41	5.04	5.78	¾	3 to 87	29	406	450	-50	266	034L0144
	CPCE 12	6.20	4.30	6.30	6.70	½	0 to 87	5.8	406	450	-58	285	034N0082
	CPCE 15	9.20	6.30	9.10	9.90	¾	0 to 87	5.8	406	450	-58	285	034N0083
CPCE 22	12.20	8.40	12.10	12.20	¾	0 to 87	5.8	406	450	-58	285	034N0084	

¹ NRD generally used in conjunction with a KVR to regulate the condensing pressure.

Spare Parts and Accessories

Description	Type(s) applied to	Danfoss Code No.
Schrader valve	all KVP, KVR	034L0006

DCL/DCB/DAS/DCR - Filter Driers

Danfoss filter driers function as simple drop-in replacements for most driers sold in the aftermarket or installed on equipment by manufacturers. All Danfoss filter driers are constructed with a solid core design to maximize moisture removal while minimizing pressure drop. These driers use a mixture of molecular sieve and activated alumina to both adsorb system moisture and capture acid and prevent solid contaminants from entering the system. The Danfoss 1.5 cubic inch hermetic filter drier can be used in hydrocarbon systems to provide exceptional protection while minimizing charge requirements.

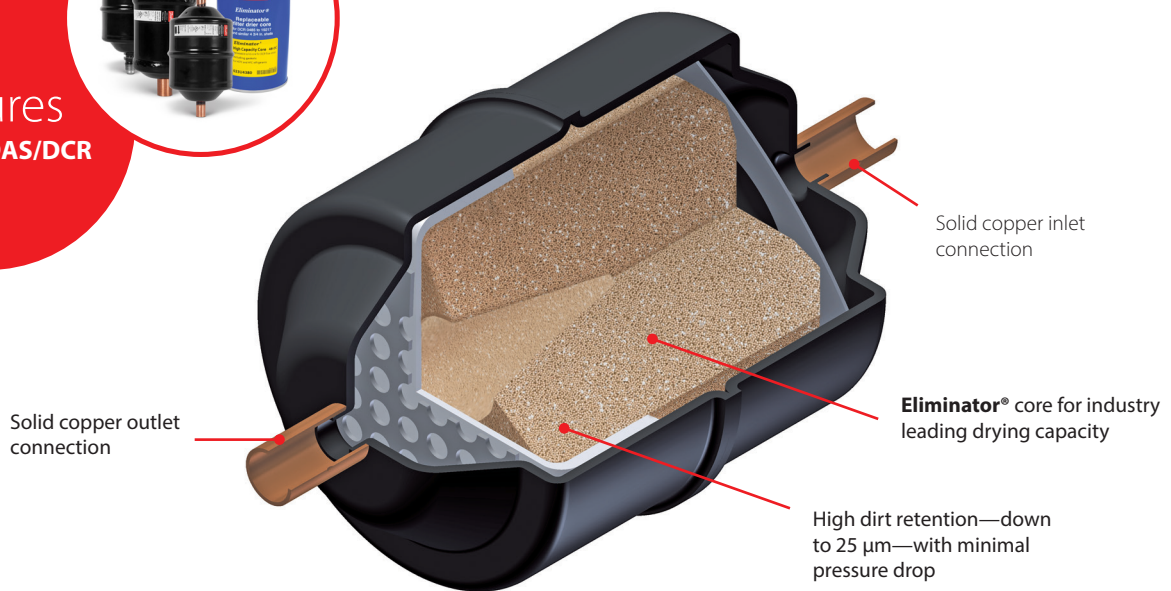

Nomenclature / Model No.

D A S 16 4 s VV

Filter drier ——— **D**

Solid Core ——— **A**

Application ——— **S**

Size (volume) ——— **16 4**

Access valves ——— **s VV**

Connection type
(blank): Flare connection
s: Solder connection

Connection
 (filter connection in 1/8 in. increments)
2/CAP: 1/4 in. inlet x cap tube outlet
2: 1/4 in.
2.5: 5/16 in.
3: 3/8 in.
4: 1/2 in.
5: 5/8 in.
6: 3/4 in.
7: 7/8 in.
9: 1 1/8 in.

	Inlet	Outlet
(blank)	none	none
V	Schrader valve	none
VV	Schrader valve	Schrader valve

A: Core with 30% molecular sieve/
 70% activated alumina (burn-out)
C: Core with 80% molecular sieve/
 20% activated alumina
M: Core with 100% molecular sieve

B: Bi-flow
L: Liquid line
S: Suction line

1.5: 1.5 in.³
03: 3 in.³
05: 5 in.³
08: 8 in.³
16: 16 in.³
30: 30 in.³
41: 41 in.³
60: 60 in.³
75: 75 in.³



Scan the QR Code for a video detailing our filter driers.

Technical data and ordering

DCL/DCB Liquid Line/Bi-flow Filter Driers

Danfoss Type	Connection (in.)	Max. working pressure (psig)	Drying capacity (lbs. of refrigerant) ²								Liquid capacity (tons) ²				Danfoss Code No.
			R-134a		R-404A		R-22		R-410A		R-134a	R-404A	R-22	R-410A	
			75 °F	125 °F	75 °F	125 °F	75 °F	125 °F	75 °F	125 °F					
DCL 1.52/2.8mms	¼ solder	667	5.10	4.60	5.30	5.10	5.10	4.60	4.60	4.20	0.80	0.50	0.90	0.80	023Z8255
DCL 032s	¼ solder	667	8.50	8.00	9.10	8.70	8.60	8.00	7.80	7.20	1.90	1.42	2.12	2.11	023Z5013 ¹
DCL 032	¼ flare	667	8.50	8.00	9.10	8.70	8.60	8.00	7.80	7.20	1.90	1.42	2.12	2.11	023Z5000 ¹
DCL 052s	¼ solder	667	13.60	12.80	14.60	13.80	13.80	12.70	12.40	11.40	2.18	1.60	2.40	2.37	023Z5018
DCL 052	¼ flare	667	13.60	12.80	14.60	13.80	13.80	12.70	12.40	11.40	2.18	1.60	2.40	2.37	023Z5002
DCL 053s	¾ solder	667	13.60	12.80	14.60	13.80	13.80	12.70	12.40	11.40	3.66	2.79	4.10	4.15	023Z5019
DCL 053	¾ flare	667	13.60	12.80	14.60	13.80	13.80	12.70	12.40	11.40	3.66	2.79	4.10	4.15	023Z5003
DCL 082s	¼ solder	667	21.70	20.50	23.30	22.10	22.00	20.30	19.80	18.20	2.18	1.55	2.37	2.28	023Z5022
DCL 082	¼ flare	667	21.70	20.50	23.30	22.10	22.00	20.30	19.80	18.20	2.18	1.55	2.37	2.28	023Z5004
DCL 083s	¾ solder	667	21.70	20.50	23.30	22.10	22.00	20.30	19.80	18.20	4.03	3.12	4.56	4.65	023Z5023
DCL 084s	½ solder	667	21.70	20.50	23.30	22.10	22.00	20.30	19.80	18.20	8.14	6.07	9.03	8.99	023Z5026
DCL 084	½ flare	667	21.70	20.50	23.30	22.10	22.00	20.30	19.80	18.20	8.14	6.07	9.03	8.99	023Z5006
DCL 162	¼ flare	667	47.70	45.10	51.30	48.60	48.30	44.70	43.50	40.10	2.18	1.54	2.36	2.28	023Z5007
DCL 163s	¾ solder	667	47.70	45.10	51.30	48.60	48.30	44.70	43.50	40.10	4.64	3.18	4.95	4.67	023Z5029
DCL 163	¾ flare	667	47.70	45.10	51.30	48.60	48.30	44.70	43.50	40.10	4.64	3.18	4.95	4.67	023Z5008
DCL 164s	½ solder	667	47.70	45.10	51.30	48.60	48.30	44.70	43.50	40.10	9.15	6.69	10.07	9.90	023Z5032
DCL 165s	¾ solder	667	47.70	45.10	51.30	48.60	48.30	44.70	43.50	40.10	12.69	10.41	14.74	15.59	023Z5033
DCL 165	¾ flare	667	47.70	45.10	51.30	48.60	48.30	44.70	43.50	40.10	12.69	10.41	14.74	15.59	023Z5010
DCL 303s	¾ solder	667	100.50	95.00	108.00	102.40	101.80	94.10	91.60	84.40	4.46	3.00	4.72	4.40	023Z0030
DCL 303	¾ flare	667	100.50	95.00	108.00	102.40	101.80	94.10	91.60	84.40	4.46	3.00	4.72	4.40	023Z0012
DCL 304s	½ solder	667	100.50	95.00	108.00	102.40	101.80	94.10	91.60	84.40	9.24	7.11	10.41	10.58	023Z0031
DCL 304	½ flare	667	100.50	95.00	108.00	102.40	101.80	94.10	91.60	84.40	9.24	7.11	10.41	10.58	023Z0013
DCL 305s	¾ solder	667	100.50	95.00	108.00	102.40	101.80	94.10	91.60	84.40	13.00	10.51	14.99	15.72	023Z0032
DCL 305	¾ flare	667	100.50	95.00	108.00	102.40	101.80	94.10	91.60	84.40	13.00	10.51	14.99	15.72	023Z0014
DCL 307s	¾ solder	667	100.50	95.00	108.00	102.40	101.80	94.10	91.60	84.40	18.27	15.34	21.44	23.05	023Z0034
DCL 415s	¾ solder	667	139.50	131.90	150.00	142.20	141.30	130.70	127.30	117.30	15.78	11.9	17.61	17.66	023Z0105
DCL 417s	¾ solder	500	139.50	131.90	150.00	142.20	141.30	130.70	127.30	117.30	18.98	16.01	22.32	24.08	023Z0106
DCL 607s	¾ solder	667	200.90	189.90	216.00	204.80	203.50	188.20	183.30	168.90	19.93	19.94	25.16	30.71	023Z0036
DCB 083s	¾ solder	667	15.60	14.70	16.70	15.80	15.60	14.50	14.10	13.00	2.10	1.50	2.30	2.30	023Z1433
DCB 163s	¾ solder	667	29.30	27.70	31.50	29.90	29.70	27.50	26.80	24.60	5.10	3.70	5.70	5.70	023Z1437
DCB 164s	½ solder	667	29.30	27.70	31.50	29.90	29.70	27.50	26.80	24.60	8.00	5.70	9.10	9.10	023Z1436
DCB 165s	¾ solder	667	29.30	27.70	31.50	29.90	29.70	27.50	26.80	24.60	10.60	8.30	11.40	11.40	023Z1435

¹ Wire mesh in filter drier outlet.

DAS Suction Line Filter Driers

Danfoss Type	Connection (in.)	Max. working pressure (psig)	Rated capacity (tons) ²			Acid capacity (oz.)	Danfoss Code No.
			R-134a	R-404A	R-22		
					R-410A		
DAS 164sVV	½ solder	500	1.70	2.40	6.30	0.30	023Z1009
DAS 165sVV	¾ solder		2.70	3.70	4.30	0.30	023Z1010
DAS 166sVV	¾ solder		3.40	4.90	5.70	0.30	023Z1011
DAS 167sVV	¾ solder		3.90	5.40	6.30	0.30	023Z1012
DAS 306sVV	¾ solder		4.00	5.40	6.30	0.64	023Z1014
DAS 307sVV	¾ solder		4.60	6.30	7.40	0.64	023Z1015
DAS 309sVV	1½ solder		5.70	7.70	8.90	0.64	023Z1016
DAS 419sVV	1½ solder		6.30	8.60	10.00	0.86	023Z1018

² For rated capacities for R-290, R-600, R-448A, R-449A, R-452A, and other HFO, HC, HFC, and HCFC refrigerants not listed, see Coolselector or contact Danfoss.

DCR Filter Drier Cores

Danfoss Type	Material	Danfoss Code No.
DCR core insert, type 48-DM solid core	100% molecular sieve	023U1392
DCR core insert, type 48-DC solid core	80% molecular sieve & 20% activated alumina	023U4381
DCR core insert, type 48-DA solid core	30% molecular sieve & 70% activated alumina	023U5381
DCR core insert, type 48-F strainer		023U1921

DCL with Schrader valve - Filter Driers

The Danfoss 1.5 hermetic filter driers include a Schrader valve, making servicing the system easy and convenient, and convertible outlet for fitting on capillary tube or ¼ inch system connection. Thanks to the solid core, Danfoss ELIMINATOR® filter driers offer exceptional drying capacity to protect the system against harmful acids and moisture. The DCL 1.5 cubic inch filter drier with Schrader makes an excellent upgrade in replacing loose bead driers due to superior drying and small internal volume.

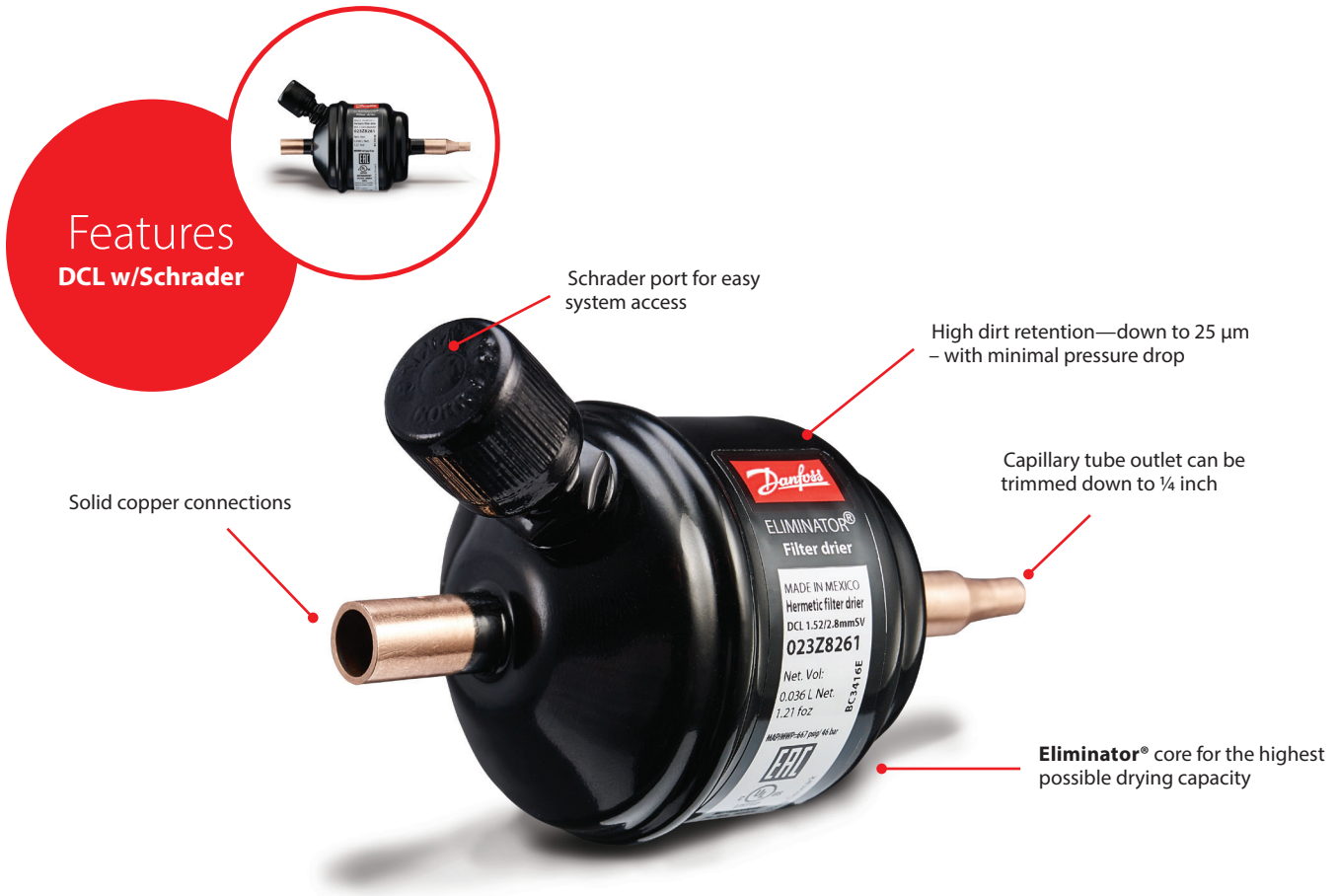

Facts

Applications:

- Traditional refrigeration
- Air conditioning units
- Transport refrigeration
- Connections:
 - Inlet: ¼ inch solder and ¼ inch service port
 - Outlet: Capillary tube outlet can be trimmed down to ¼ inch
- Refrigerants: R-22, R-32, R-134a, R-404A, R-410A, R-407C/F, R-23, R-1234yf, R-1234ze, R-452A, R-444B, R-449A, R-448A, R-450A, R-507. For other refrigerants, please contact Danfoss.
- Available with 1.5, 3, and 5 cubic inch solid core volumes
- 80% molecular sieve and 20% activated alumina core

Technical data and ordering

DCL with Schrader valve - Filter Drier

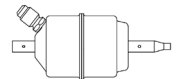

Danfoss Type	Connection inlet (in.)/ outlet	Max. working pressure (psig)	Drying capacity (lbs. of refrigerant)										Liquid capacity (tons)					Danfoss Code No.
			R-134a		R-404A		R-22		R-407C		R-410A		R-134a	R-404C	R-22	R-407C	R-410A	
			75°F	125°F	75°F	125°F	75°F	125°F	75°F	125°F	75°F	125°F						
DCL 1.52/ CAPsV	¼/capillary tube	667	5.2	4.8	5.5	5.2	5.3	4.9	5.1	4.7	4.7	4.2	1.0	0.7	1.1	1.0	1.0	023Z8261
DCL 032/ CAPsV	¼/capillary tube	667	8.4	7.7	8.8	8.3	8.5	7.8	8.2	7.6	7.6	6.8	1.2	0.8	1.3	1.2	1.2	023Z5174
DCL 052/ CAPsV	¼/capillary tube	667	13.5	12.4	14.1	13.4	13.6	12.5	13.1	12.1	12.3	10.9	1.2	0.8	1.3	1.2	1.2	023Z5181

GBC V2 - Ball Valves

Danfoss GBC ball valves are manually operated shut-off valves suitable for bi-directional flow. The design, weld, and choice of the sealing material enable these ball valves to meet the most demanding requirements and provide years of leak-free performance.

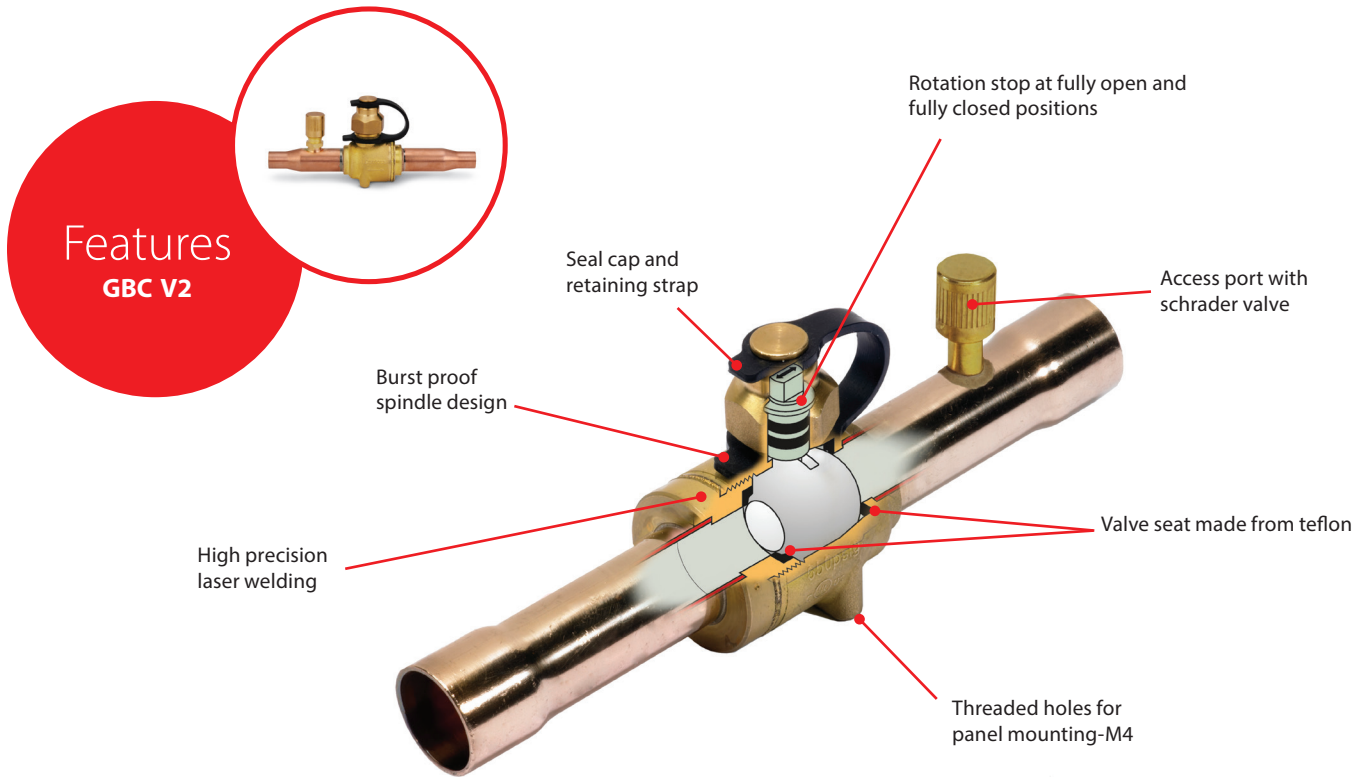

Product Selection

Danfoss Type	Solder ODF connection (in.)	Flow Coefficient, C _v value ¹ (gal/min)	Working pressure (psig)	Danfoss Code No. ¹
GBC 6s	¼	2.12	650	009L8050
GBC 10s	⅜	9.29		009L8051
GBC 12s	½	15.22		009L8052
GBC 16s	⅝	18.10		009L8053
GBC 18s	¾	25.35		009L8054
GBC 22s	7⁄8	38.54		009L8065
GBC 28s	1 ¼	71.96		009L8066
GBC 35s	1 ⅜	107.23		009L8067
GBC 42s	1 ⅝	155.78		009L8068
GBC 54s	2 ⅛	277.57		009L8059
GBC 67s	2 ⅝	424.69	009L8069	

¹ All valves listed in table above are Full Port.

Spare Parts and Accessories

Description	Type(s) applied to	Danfoss Code No.
Ball valve service kit	GBC 6, 10, 12, 16, 18, 22	009G7012
Ball valve service kit	GBC 28, 35	009G7014
Ball valve service kit	GBC 42, 54, 67	009G7016

Codes listed above are for GBC V1; for GBC V2 spare parts and accessories, contact Danfoss.

Seal Cap Kit

Type	Valve connection size in.	Industrial pack (no. of pcs)	Code no. for 009GXXXX series	Code no. for 009LXXXX 650 psig series
GBC 6s – GBC 12s	¼–½	6	009G7210	009L7209
GBC 16s – GBC 22s	⅝–7⁄8	6		009L7210
GBC 28s – GBC 35s	1 ⅛–1 ⅜	4 3	009G7211	— 009L7211
GBC 42s – GBC 79s	1 ⅝–3 ⅛	4 3	009G7212	— 009L7212

Bracket Kit

Type	Valve connection size in.	Industrial pack (no. of pcs)	Code no. for 009GXXXX series	Code no. for 009LXXXX 650 psig series
GBC 6s – GBC 12s	¼–½	12	009G7084	009G7089
GBC 16s	⅝	12		009G7084
GBC 18s – GBC 22s	¾–7⁄8	12	009G7085	
GBC 28s	1 ⅛	10	009G7086	
GBC 35s	1 ⅜	5	009G7087	
GBC 42s	1 ⅝	4	009G7088	

NRV V2 - Check Valves

NRV V2 one-piece check valves are used in liquid suction and hot gas lines in refrigeration and air conditioning applications. NRV valves ensure the correct flow direction and prevent back-condensation from a warm part of the system to the cold evaporator. The hermetic design of solder version meets environmental demands for today and the future. The built-in damping piston makes the valves suitable for installation in lines where pulsation can occur, e.g., in a compressor discharge line.

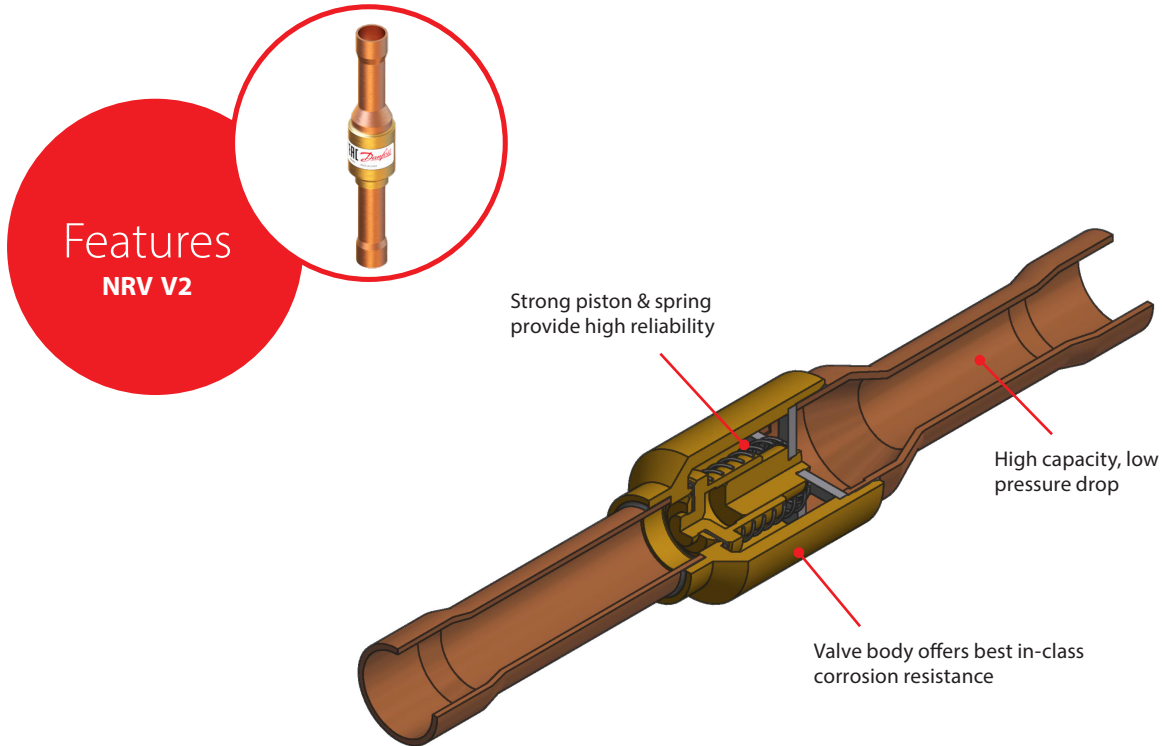

Product Selection

Valve Type	Connection Type	Connection	Min. OPD Δp ¹	C_v value ²	Danfoss Code No.
		in.	psi	gal./min.	
NRV 6s V2	Straightway, solder	¼	0.58	0.77	020B1010
NRV 10s V2	Straightway, solder	¾	0.58	1.90	020B1011
NRV 12s V2	Straightway, solder	½	0.29	2.89	020B1012
NRV 16s V2	Straightway, solder	¾	0.29	4.62	020B1018

¹ Δp = Minimum Opening Pressure Differential

² The C_v value is the flow of water in gal./min. at a pressure drop across valve of 14.5 psi; $\rho = 62.4 \text{ lbs./ft}^3 = 8.34 \text{ lbs./gal.}$

SGP - Sight Glasses

Danfoss sight glasses with hard crystal view ports are designed to accurately indicate the presence of moisture in refrigeration and air-conditioning systems. When system moisture content rises above permissible levels, the “dry/green” indicator will change to yellow indicating a “wet” system. The indication of dangerous moisture levels is essential in helping prevent the formation of harmful acids which are detrimental to the system. The SGP sight glass is simply the best-made sight glass available today.

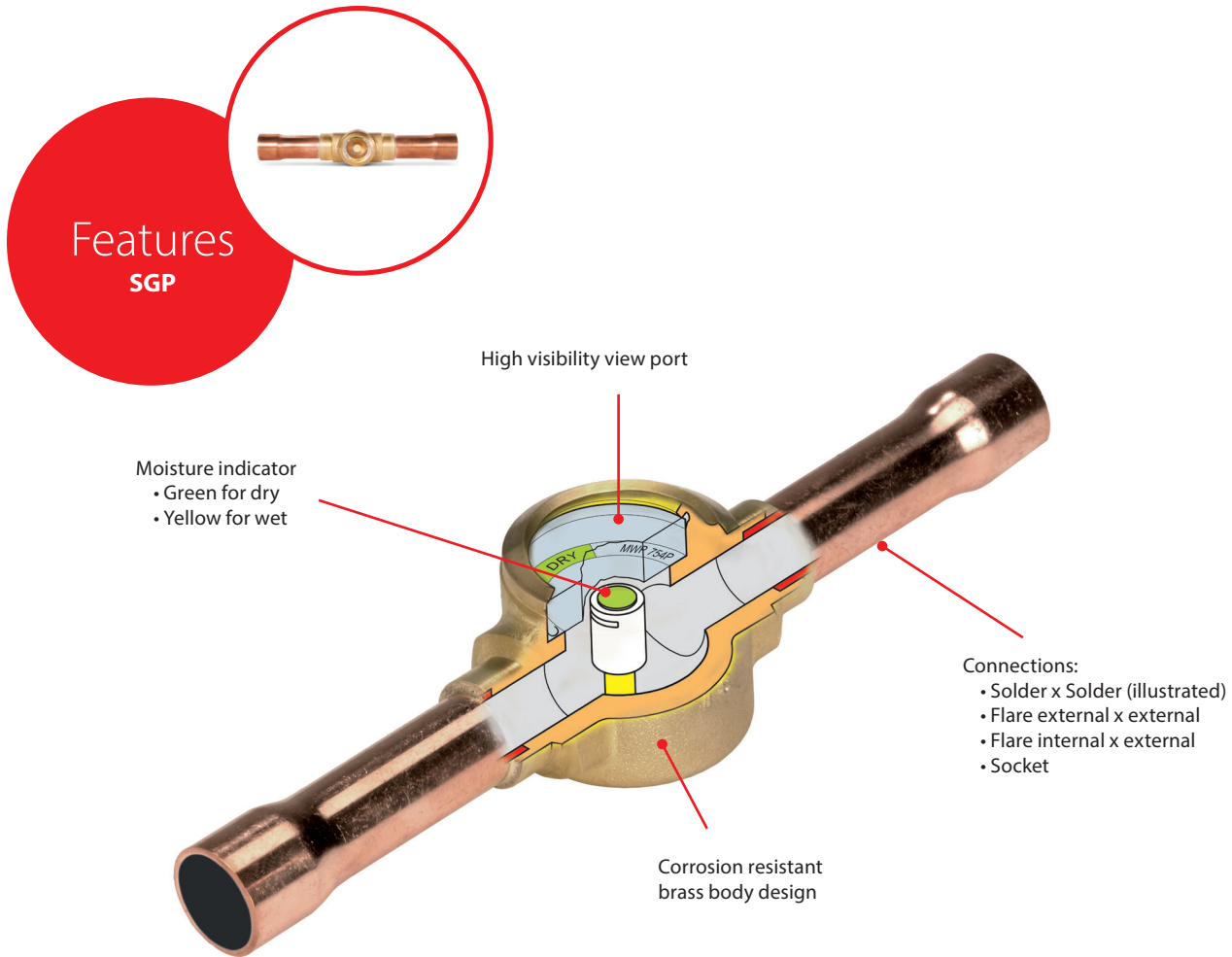

Product Selection

Danfoss Type	Version	Connection (in.)	Ambient temperature (°F)	Maximum working pressure (psig)	Danfoss Code No.
SGP 6 N	Flare int. x ext. ¹	¼ x ¼	-60 to 175	750	014L0171
SGP 10 N		⅜ x ⅜			014L0172
SGP 12 N		½ x ½			014L0173
SGP 6s N	ODF x ODF solder	¼ x ¼			014L0181
SGP 10s N		⅜ x ⅜			014L0182
SGP 12s N		½ x ½			014L0183
SGP 16s N		⅝ x ⅝			014L0145
SGP 22s N		⅞ x ⅞			014L0186
SGP ½ RN	NPT	½			

¹ Can be screwed directly onto Danfoss filter drier.

Optyma™ - Condensing Units

Danfoss Optyma™ line of light commercial condensing units is available with sizes ranging from 1/8 hp to 13 1/2 hp for low and medium temperature applications for R-404A and R-134a. Its contractor-friendly design makes Optyma easy to install, quiet, and efficient.

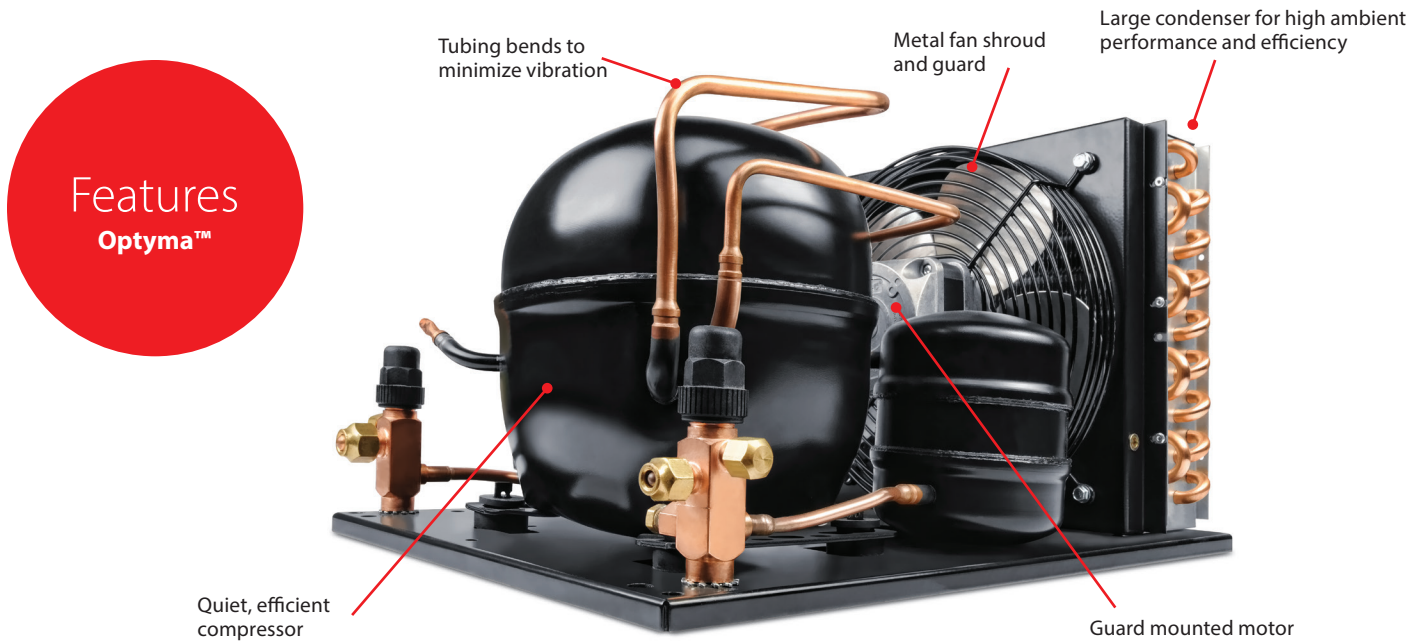

Application	Design	Refrigerant	Condenser size	HP rating	Certification	Version	Electrical code
H	N	X	M	0300	U	WG000	Q

Application:
L: Low
H: High or Medium / High
M: Medium or Low/Medium
U: Universal Low / Medium / High

Design:
C: Air cooled condenser, Single fan, Recip
J: Air cooled condenser, Slim Design, Recip
G: Air cooled condenser, Twin fan, Recip
N: Air cooled condenser, Slim Design, Scroll
R: Air cooled condenser, Twin fan, Scroll

Refrigerant:
G: R134a
H: R404A/R507/R452A
M: R22 Replacement
N: R290
Z: R404A/R507A/R134a*/R448A/R449A/R452A
X: R448A/R449A/R404A/R507A/R134a/R452A
Y: R448A/R449A/R404A/R507A/R452A
S: R410A/R454B

Condenser size:
C: Fin and Tube condenser size 110F ambient
M: Microchannel Condenser size 115F ambient

HP rating:
 HP rating in hundredths of HP,
 i.e.: 0033=1/3 HP, 1000 = 10 HP

Certification:
R: UL Recognized
U: UL Listed

Electrical code:
B: Compressor & fan(s), 115V, 1ph, 60 Hz
N: Compressor & fan(s), 230V, 1ph, 60 Hz
Q: Compressor 208-230V, 3ph, 60 Hz
 Fan(s) 230V, 1ph, 60 Hz
R: Compressor 460V, 3ph, 60 Hz
 Fan(s) 460V, 1ph, 60 Hz

Version:
DF: Plastic baseplate
WA: Power cord
WB: Power cord, Receiver
WC: Electrical box, Receiver
WD: Electrical box, Receiver,
 Low pressure control
WE: Electrical box, Receiver, Dual pressure
 control, Fan cycling control, larger than 3HP
 dual fan units use KPU fan cycling control
WF: WE + Filter drier, Sight glass, Solenoid valve
 with coil
WG: BX, Receiver, Dual pressure control, Fan
 speed controller or Fan cycling, Defrost
 Timer, Outdoor enclosure (MBP)
WH: Electrical box, Receiver, Dual pressure
 control, Fan speed controller or Fan cycling,
 Defrost timer, Outdoor enclosure, Suction
 Accumulator (LBP)
WJ: Electrical box, Receiver, Dual pressure control,
 Fan cycling control, Filter drier, Sight glass

* R134a is available in MBP only

Rating Conditions (ARI)

Application	LBP	MBP/HBP
Ambient Temp	90°F	90°F
Return Gas	40°F	65°F
SubCooling	5°F	5°F



Scan the QR Code for the latest Optyma Condensing Unit and Spare Parts Catalog.

Optyma™ condensing unit R448A/R449A - H/MBP

Fan	Model no	Version	Electrical code	Code no	Compressor model	Amb. temp.	Capacity range in (btu/hr) at evaporating temperature											Power consumption [W] at evap. temp. 20°F				
						°F	-10	-5	0	5	10	15	20	25	30	35	40		45	50		
Single fan	HCYC0075R	C0001 C0002	N	114N2088 114N2107	MPT14RF	90					2870	3204	3552	3913	4286	4670	5063	5465	5875	6294	1024	
						95					2720	3032	3360	3701	4054	4419	4795	5180	5575	5979		
						100					2570	2860	3167	3488	3823	4169	4527	4895				
						105								2689	2975	3276	3591	3919	4259			
						110									2848	3136	3438	3754				
	HCYC0100R	C0001 C0002	N	114N2089 114N2108	MX18TGa	90	2290	2625	2974	3335	3707	4089	4481	4881	5289	5705	6128	6558	6996	1198		
						95	2137	2445	2768	3105	3454	3814	4184	4563	4952	5348	5753	6166	6588			
						100		2266	2564	2876	3201	3539	3887	4246	4614	4992	5378					
						105			2360	2648	2950	3264	3591	3929	4277							
	HCYC0075R	C0001 C0002	B	114N2102 114N2109	MPT14RD	90					2926	3266	3621	3989	4369	4761	5161	5571	5989	6416	1068	
						95					2773	3091	3425	3773	4133	4505	4888	5280	5683	6095		
						100					2620	2915	3228	3556	3897	4250	4615	4990				
						105							2741	3033	3340	3661	3995	4342				
						110					2903	3197	3505	3827								

Test condition

Return gas temperature 65°F

Subcooling 5°F

Electrical code

B: Compressor & fan(s) 115V, 1 ph, 60 Hz

N: Compressor & fan(s) 230V, 1 ph, 60 Hz

Version

C0001: Multi Pack

C0002: Single Pack

HP rating in hundredths of HP, ie.: 033=1/3hp, (UCGC0100U:0100=1hp)

Power consumption referred at 90°F ambient temperature

Optyma™ condensing unit R290 – L/MBP

Fan	Model no	Version	Electrical code	Code no	Compressor model	Amb. temp.	Capacity range in (btu/hr) at evaporating temperature									Power consumption [W] at evap. temp. -10 F	Power Consumption [W] at evap. Temp. 20°F	
						°F	-30	-20	-10	0	10	20	30	40	50			
Single fan	MCNC0015R	DF600 DF602	B	114N2090 114N2117	NBC30NR	90	313	425	596	758	950	1171	1403				118	155
						95	294	382	573	717	910	1120	1341					
						100	278	360	543	681	870	1073	1278					
						105	262	339	514	645	829	1026	1216					
	MCNC0020R	DF600 DF602	B	114N2092 114N2119	NUT55LRb	90	790	999	1299	1537	1816	2091	2383				186	268
						95	743	910	1252	1464	1744	2007	2297					
						100	702	859	1193	1397	1670	1925	2208					
						105	661	809	1133	1329	1595	1844						
	MCNC0033R	WA000 WA002	B	114N2097 114N2123	DLE6.5CN	90	950	1177	1523	1798	2118	2432	2766	3099			244	334
						95	891	1054	1467	1704	2027	2326	2657					
						100	839	990	1392	1619	1934	2223						
						105	788	927	1318	1535	1840							
	MCNC0050R	DF600 DF602	B	114N2094 114N2121	NLY12NRb	90	1122	1494	2019	2508	3065	3637	4240	4850			398	574
						95	1069	1375	1956	2399	2950	3495	4084					
						100	1024	1313	1875	2301	2832	3357	3927					
						105	978	1252	1795	2202	2715	3220	3725					
	MCNC0050R	WA000 WA002	B	114N2091 114N2118	NLY12NRb	90	1122	1494	2019	2508	3065	3637	4240	4850			398	574
						95	1069	1375	1956	2399	2950	3495	4084					
						100	1024	1313	1875	2301	2832	3357	3927					
						105	978	1252	1795	2202	2715	3220	3725					
MCNC0075R	DF600 DF602	B	114N2095 114N2122	NPT14ND	90	1438	1881	2552	3206	3972	4776	5637			518	741		
					95	1370	1733	2475	3073	3831	4598							
					100	1311	1657	2376	2952	3684	4425							
					105	1252	1581	2278	2831	3538	4253							
LCNC0075R	DF600	B	114N2104	NPT16LR	90	1239	1569	2065	2505	3001					566	-		
					95		1436	1997	2389									
					100		1368	1911	2284									
					105		1301	1824										
MCNC0075R	WA000 WA002	B	114N2098 114N2124	NPT14 ND	90	1438	1881	2552	3206	3972	4776	5637			513	734		
					95	1370	1733	2475	3073	3831	4598							
					100	1311	1657	2376	2952	3684	4425							
					105	1252	1581	2278	2831	3538	4253							
MCNC0075R	WA000 WA002	N	114N2099 114N2125	SCE15MNX	90			2857	3568	4391	5262	6232	7275	8905	509	682		
					95			2754	3404	4229	5066	6018	7021	8598				
					100			2629	3250	4050	4855	5773	6738					
					105			2505	2941	3611	4807	5389	6564					
MCNC0100R	WA000 WA002	B	114N2100 114N2126	SCE18MNX	90			3263	4033	4947	5897	6941	8030	9828	612	813		
					95			3166	3841	4753	5646	6666	7704	9434				
					100			3008	3651	4541	5401	6389	7390					
					105			2846	3461	4329	5157	6113						
MCNC0100R	WA000 WA002	B	114N2101 114N2127	NPT16NF	90	2138	2840	3765	4579	5511	6454	7457	8477		637	909		
					95	2019	2571	3628	4350	5282	6181	7174	8163					
					100	1915	2430	3452	4143	5045	5917	6885						
					105	1811	2289	3275	3935	4808	5653	6596						

Test condition

Return gas temperature 65°F
Subcooling 5°F

Electrical code

B: Compressor & fan(s) 115V, 1 ph, 60 Hz
N: Compressor & fan(s) 230V, 1 ph, 60 Hz

Version

DF: Plastic baseplate
WA: Power cord

HP rating in hundredths of HP, ie.: 033=1/3hp, (UCGC0100U:0100=1hp)
Power consumption referred at 90°F ambient temperature

Optyma™ - Condensing Units (1/5)

R-404A MBP/ R-507 MBP			Ambient temperature (°F)	Capacity range in btu/h ASHRAE ¹ at evaporating temperature (°F)										AWEF rating		
Competitor Model Nos.	Danfoss Model No.	Danfoss Code No.		0	5	10	15	20	25	30	35	40	45		50	
AEA9415 M4FH0022	UCHC0020RWA000B	114N2316	90	1000	1100	1250	1400	1500	1650	1800	2000	2150	2300	N/A		
			95	950	1050	1200	1300	1450	1600	1750	1900	2050	2200			
			100	900	1000	1100	1250	1350	1500	1650	1800					
			110	800	900	1000	1150	1250	1400	1500						
AEA9422 M4FH0025	UCHC0025RWB000B	114N2318	90	1650	1850	2050	2250	2450	2650	2900	3150	3400	3650	N/A		
			95	1600	1750	1950	2150	2350	2550	2800	3000	3250	3500			
			100	1500	1650	1850	2050	2250	2450	2650	2900	3100	3350			
			110	1350	1550	1700	1850	2050	2250							
AKA9429 M4FHA036	UCHC0033RWC000B	114N2321	90	2050	2250	2500	2750	3000	3250	3550	3850	4100	4450	N/A		
			95	1950	2150	2400	2600	2850	3100	3400	3650	3950	4250			
			100	1850	2050	2250	2500	2700	2950	3200	3500	3750	4050			
			110	1650	1850	2050										
AKA9440 M4FH0050	UCHC0050UWC000B UCHC0050UWC000N	114N2324	90	2450	2750	3100	3400	3750	4100	4500	4900	5250	5700	N/A		
			95	2300	2600	2900	3200	3550	3850	4250	4600	4950	5350			
		114N2325	100	2100	2400	2700	3000	3300	3600	3950	4300	4650	5000			
			110	1850	2100	2350	2600	2850	3150							
	HCHC0060UWC000B	114N2328	90	3400	3750	4200	4600	5050	5550	6050	6600	7100	7700	N/A		
			95	3200	3550	3950	4350	4800	5250	5750	6250	6750	7300			
			100	3000	3350	3700	4100	4500	4950	5400	5900	6400	6900			
			110	2650	2950	3300	3700	4050	4450	4900						
	HCHC0075UWC000B HCHC0075UWC000N	114N2330	90	4400	4950	5500	6150	6800	7500	8250	9000	9800	10650	N/A		
			95	4150	4700	5250	5850	6500	7200	7900	8650	9400	10250			
		114N2331	100	3900	4450	5000	5600	6200	6850	7550	8300	9050	9850			
			110	3500	4000	4550	5100	5700	6350	7000						
AJA7480 FJAMA100 FJAMA101 FJAMA106 FJAMA100	HCHC0100UWD000N	114N2332	90		5900	6650	7450	8200	9000	9850	10650	11450	12300	N/A		
			95		5600	6350	7100	7800	8600	9350	10150	10950	11750			
			100			6000	6700	7400	8150	8900	9650	10400	11150			
			110				6100	6750	7400	8100	8800					
AWA7512 FJAMA125 FJAMA126 FJAMA150	HCZC0150UWJ300N HCZC0150UWJ300Q HCZC0150UWJ300R	114N3601	90				9989	11300	12670	14100	15590	17120	18700	20310	7.07	
			95					9438	10690	12000	13370	14780	16240	17750		19280
		114N3602	100					8879	10080	11320	12620	13970	15360	16790		18250
			105					8313	9451	10640	11870	13150	14470	15820		17200
		114N3603	110					7742	8822	9949	11120	12330	13580			
AWA7515 VJAF017H FJAMA200	HCZC0200UWJ300N HCZC0200UWJ300Q HCZC0200UWJ300R	114N3604	90				13320	14880	16510	18210	19960	21750	23590	25460	7.93	
			95					12660	14140	15690	17290	18950	20650	22380		24150
		114N3605	100					11970	13380	14840	16360	17920	19520	21160		22820
			105					11260	12590	13970	15400	16870	18380	19910		21470
		114N3606	110					10530	11780	13080	14420	15800	17210			
VJAF025H	HCZC0250UWJ300N HCZC0250UWJ300Q HCZC0250UWJ300R	114N3607	90				16910	18680	20500	22380	24310	26270	28260	30270	7.66	
			95					16110	17790	19520	21310	23130	24980	26870		28760
		114N3608	100					15290	16880	18530	20210	21930	23680	25450		27240
			105					14450	15960	17510	19100	20720	22370	24030		25700
		114N3609	110					13600	15020	16480	17970	19490	21040			

¹ Ambient temperature = 90 °F, Return gas = 65 °F, Subcooling = 5 °F

Full range of models (refrigerants, capacities, and voltages codes), spare parts, and more available at <https://bit.ly/CUCatalogNAM>.
Check Coolselector or contact Danfoss.

Optyma™ - Condensing Units (2/5)

R-404A MBP/ R-507 MBP			Ambient temperature (°F)	Capacity range in btu/h ASHRAE ¹ at evaporating temperature (°F)											AWEF rating
Competitor Model Nos.	Danfoss Model No.	Danfoss Code No.		0	5	10	15	20	25	30	35	40	45	50	
			90				20820	23050	25350	27690	30080	32500	34930	37360	
	HCZC0275UWJ300N	114N3610	95				19740	21860	24050	26280	28540	30830	33130	35420	
	HCZC0275UWJ300Q	114N3611	100				18660	20680	22750	24860	27000	29160	31330	33490	7.66
	HCZC0275UWJ300R	114N3612	105				17580	19490	21450	23440	25460	27500	29540	31560	
			110				16500	18310	20150	22030	23930	25850			
			90				23390	25810	28300	30830	33380	35950	38520	41060	
	HCZC0300UWJ300N	114N3614	95				22180	24490	26850	29240	31660	34090	36510	38910	8.23
	HCZC0300UWJ300Q	114N3615	100				20980	23170	25400	27660	29940	32230	34510	36770	8.23
	HCZC0300UWJ300R	114N3616	105				19780	21850	23950	26080	28230	30390	32530	34640	8.18
			110				18590	20530	22510	24520	26540	28550			
			90				31480	35020	38720	42580	46590	50730	54980	59340	
	HGZC0400UWJ300N	114N3617	95				29880	33270	36820	40510	44330	48280	52330	56480	
	HGZC0400UWJ300Q	114N3618	100				28260	31490	34880	38390	42040	45790	49650	53580	8.68
	HGZC0400UWJ300R	114N3619	105				26600	29690	32910	36260	39720	43280	46940	50670	
			110				24930	27860	30920	34100	37380	40760			
			90				38340	42410	46630	50980	55440	59980	64600	69260	
	HGZC0500UWJ300N	114N3621	95				36310	40200	44210	48350	52580	56900	61280	65700	8.23
	HGZC0500UWJ300Q	114N3622	100				34270	37970	41780	45700	49720	53810	51960	62130	8.23
	HGZC0500UWJ300R	114N3623	105				32220	35720	39340	43050	46850	50710	54630	58570	8.16
			110				30170	33480	36890	40390	43980	47620			
			90				49600	54670	59940	65380	70990	76730	82580	88530	
	VJAF035Z	HGZC0700UWJ300Q	95				47120	51940	56950	62120	67440	72890	78440	84070	
	VJA035H	HGZC0700UWJ300R	100				44610	49190	53940	58840	63880	69030	74280	79600	8.03
			105				42090	46420	50900	55530	60290	65160	70110	75130	7.97
			110				39550	43630	47860	52220	56700	61280			
			90				60260	67010	74070	81430	89080	97000	105200	113500	
	FJAMB400	HGZC0900UWJ300Q	95				57030	63470	70210	77230	84520	92050	99810	107800	8.59
	VJAF040Z	HGZC0900UWJ300R	100				53800	59940	66350	73030	79950	87110	94470	102000	
	VJAF040H		105				50570	56400	62490	68820	73580	82160	89130	96270	
	FJAMB500		110				47350	52870	58630	64620	70820	77230			
	VJAF050Z		90				75520	83250	91320	99710	108400	117400	126600	136000	
	FJAH100Z	HGZC1000UWJ300Q	95				71710	79080	86780	94770	103000	111600	120300	129300	
		HGZC1000UWJ300R	100				67860	74880	82210	89800	97660	105700	114000	122500	8.32
			105				63980	70660	77610	84810	92250	99910	107700	115700	
			110				60090	66410	72990	79800	86830	94050			
			90				87530	96260	105400	114800	124500	134500	144800	155200	
	HGZC1200UWJ300Q	114N3633	95				83140	91470	100100	109100	118400	127900	137600	147500	8.04
	HGZC1200UWJ300R	114N3634	100				78710	86630	94860	103400	112200	121200	130400	139800	
			105				74230	81750	89550	97630	106000	114500	123200	132000	
			110				69730	76830	84210	91840	99690	107700			
			90				94170	103400	112900	122900	133100	143600	154300	165200	
	FJAH120Z	HGZC1350UWJ300Q	95				89460	98240	107400	116800	126500	136500	146700	157000	
	FJAM130Z	HGZC1350UWJ300R	100				84750	93100	101800	110800	120000	129500	139100	148900	7.9
			105				80020	87960	96190	104700	113400	122400	131500	140700	
			110				75300	82810	90600	98630	106900	115300			

¹ Ambient temperature = 90 °F, Return gas = 65 °F, Subcooling = 5 °F

Full range of models (refrigerants, capacities, and voltages codes), spare parts, and more available at <https://bit.ly/CUCatalogNAM>.

Check Coolselector or contact Danfoss.

Optyma™ - Condensing Units (3/5)

R-448A MBP/ R-449A MBP			Ambient temperature (°F)	Capacity range in btu/h ASHRAE ¹ at evaporating temperature (°F)							AWEF rating	
Competitor Model Nos.	Danfoss Model No.	Danfoss Code No.		15	20	25	30	35	40	45		50
			90	8586	9756	10990	12280	13620	15020	16460	17960	
	HCZC0150UWJ300N	114N3601	95	8110	9234	10420	11650	12950	14290	15680	17110	
	HCZC0150UWJ300Q	114N3602	100	7644	8723	9857	11040	12280	13570	14900	16270	7.58
	HCZC0150UWJ300R	114N3603	105	7188	8222	9308	10440	11630	12860	14130	15450	
			110	6744	7732	8770	9857	10990	12160	13380	14630	
			90	11590	12990	14490	16080	17750	19500	21320	23210	
	HCZC0200UWJ300N	114N3604	95	11060	12390	13820	15330	16930	18600	20330	22130	
	HCZC0200UWJ300Q	114N3605	100	10530	11800	13160	14590	16110	17700	19350	21060	8.16
	HCZC0200UWJ300R	114N3606	105	10010	11210	12500	13860	15300	16810	18380	20000	
			110	9488	10630	11850	13140	14500	15930	17410	18950	
			90	14170	15860	17660	19550	21540	23610	25750	27960	
	HCZC0250UWJ300N	114N3607	95	13520	15130	16830	18640	20530	22500	24540	26650	6.77
	HCZC0250UWJ300Q	114N3608	100	12880	14400	16020	17730	19530	21400	23350	25350	7.15
	HCZC0250UWJ300R	114N3609	105	12240	13680	15220	16840	18540	20320	22160	24060	7.32
			110	11600	12970	14420	15950	17560	19240	20980	22780	
			90	18050	20130	22290	24530	26830	29190	31570	33990	
	HCZC0275UWJ300N	114N3610	95	17220	19200	21270	23400	25590	27830	30100	32390	6.77
	HCZC0275UWJ300Q	114N3611	100	16390	18270	20240	22270	24350	26470	28630	30800	7.15
	HCZC0275UWJ300R	114N3612	105	15560	17350	19210	21130	23110	25120	27160	29220	7.32
			110	14720	16420	18180	20000	21870	23770	25700	27640	
			90	20390	22700	25090	27560	30080	32640	35230	37820	
	HCZC0300UWJ300N	114N3614	95	19430	21630	23920	26260	28660	31090	33550	36020	7.32
	HCZC0300UWJ300Q	114N3615	100	18470	20570	22740	24970	27240	29550	31880	34210	7.34
	HCZC0300UWJ300R	114N3616	105	17520	19510	21560	23670	25830	28010	30210	32420	7.52
			110	16570	18450	20390	22380	24410	26480	28550	30630	
			90	26130	29570	33220	37070	41100	45300	49670	54170	
	HGZC0400UWJ300N	114N3617	95	24900	28200	31690	35380	39240	43270	47450	51770	
	HGZC0400UWJ300Q	114N3618	100	23660	26820	30160	33690	37390	41240	45240	49370	8.86
	HGZC0400UWJ300R	114N3619	105	22410	24530	28630	31990	35520	39210	43020	46970	
			110	21160	24040	27090	30300	33660	37170	40810	44570	
			90	32200	36160	40310	44650	49160	53810	58600	63500	
	HGZC0500UWJ300N	114N3621	95	30610	34410	38400	42570	46890	51360	55960	60660	8.49
	HGZC0500UWJ300Q	114N3622	100	29040	32680	36510	40500	44640	48920	53320	57820	8.49
	HGZC0500UWJ300R	114N3623	105	27480	30970	34620	38440	42410	46500	50710	55010	8.40
			110	25940	29270	32760	36400	40180	44090	48110	52210	
			90	43870	48970	54330	59930	65750	71780	77980	84330	
	HGZC0700UWJ300Q	114N3626	95	41900	46800	51930	57300	62880	68650	74590	80670	8.55
	HGZC0700UWJ300R	114N3627	100	39930	44610	49530	54660	60000	65520	71190	77000	8.47
			105	37940	42420	47120	52020	57120	62380	67800	73340	
			110	35950	40220	44700	49380	54230	59250	64410	69690	
			90	52540	59390	66680	74390	82510	91020	99900	109100	
	HGZC0900UWJ300Q	114N3628	95	49960	56530	63520	70920	78720	86890	95410	104300	
	HGZC0900UWJ300R	114N3629	100	47410	53700	60400	67490	74960	82790	90960	99450	8.74
			105	44890	50900	57310	64090	71240	78730	86550	94680	
			110	42410	48140	54250	60720	67550	74710	82180	89940	
			90	66450	74950	83960	93470	103400	113900	124700	135900	
	HGZC1000UWJ300Q	114N3631	95	63170	71330	79980	89100	98690	108700	119100	129900	
	HGZC1000UWJ300R	114N3632	100	59930	67740	76030	84770	93960	103600	113500	123900	8.73
			105	56720	64190	72110	80480	89270	98470	108000	117900	
			110	53550	60670	68240	76230	84630	93410	102600	112000	
			90	78110	86970	96280	106000	116200	126700	137500	148700	
	HGZC1200UWJ300Q	114N3633	95	74470	82980	91920	101300	111000	121100	131600	142300	
	HGZC1200UWJ300R	114N3634	100	70870	79040	87620	96590	105900	115600	125600	135900	8.61
			105	67330	75150	83370	91970	100900	110200	119800	129600	
			110	63850	71320	79180	87400	95950	104800	114000	123400	
			90	83580	92920	102700	112900	123500	134500	145800	157300	
	HGZC1350UWJ300Q	114N3636	95	79660	88630	98030	107800	118000	128500	139300	150400	
	HGZC1350UWJ300R	114N3637	100	75790	84400	93410	102800	112600	122600	133000	143600	8.12
			105	71990	80220	88850	97840	107200	116800	126700	136800	
			110	68240	76110	84350	92930	101800	111000	120500	130100	

¹ Ambient temperature = 90 °F, Return gas = 65 °F, Subcooling = 5 °F

Full range of models (refrigerants, capacities, and voltages codes), spare parts, and more available at <https://bit.ly/CUCatalogNAM>.

Check Coolselector or contact Danfoss.

Optyma™ - Condensing Units (4/5)

R-452A MBP			Ambient temperature (°F)	Capacity range in btu/h ASHRAE ¹ at evaporating temperature (°F)								AWEF rating
Competitor Model Nos.	Danfoss Model No.	Danfoss Code No.		15	20	25	30	35	40	45	50	
			90	9663	10850	12100	13400	14760	16170	17630	19120	
	HCZC0150UWJ300N	114N3601	95	9109	10240	11430	12670	13970	15310	16690	18120	
	HCZC0150UWJ300Q	114N3602	100	8558	9636	10770	11950	13180	14450	15770	17120	7.64
	HCZC0150UWJ300R	114N3603	105	8010	9034	10110	11230	12400	13600	14850	16130	
			110	7466	8436	9453	10510	11620	12760	13940	15160	
			90	12930	14340	15820	17360	18950	20580	22260	23970	
	HCZC0200UWJ300N	114N3604	95	12260	13610	15010	16480	17990	19540	21140	22760	
	HCZC0200UWJ300Q	114N3605	100	11590	12880	14210	15600	17040	18510	20030	21570	8.24
	HCZC0200UWJ300R	114N3606	105	10930	12150	13420	14740	16100	17490	18920	20380	
			110	10280	11440	12640	13880	15160	16480	17830	19200	
			90	15430	17050	18780	20610	22540	24540	26620	28760	
	HCZC0250UWJ300N	114N3607	95	14650	16180	17810	19540	21350	23240	25210	27230	
	HCZC0250UWJ300Q	114N3608	100	13860	15300	16830	18450	20160	21940	23790	25700	7.60
	HCZC0250UWJ300R	114N3609	105	13070	14410	15840	17360	18960	20630	22370	24170	
			110	12260	13510	14850	16260	17760	19330	20960	22640	
			90	19170	21110	23130	25230	27390	29600	31850	34130	
	HCZC0275UWJ300N	114N3610	95	18200	20030	21940	23920	25960	28040	30160	32310	7.60
	HCZC0275UWJ300Q	114N3611	100	17220	18940	20740	22600	24510	26470	28470	30490	7.73
	HCZC0275UWJ300R	114N3612	105	16220	17840	19520	21260	23060	24900	26770	28670	7.73
			110	15210	16720	18290	19920	21600	23320	25070	26850	
			90	22110	24310	26590	28930	31320	33740	36180	38630	
	HCZC0300UWJ300N	114N3614	95	20990	23060	25200	27390	29640	31910	34200	36490	7.73
	HCZC0300UWJ300Q	114N3615	100	19840	21780	23790	25840	27940	30070	32210	34350	7.73
	HCZC0300UWJ300R	114N3616	105	18680	20490	22360	24270	26230	28210	30210	32210	7.73
			110	17490	19180	20910	22690	24510	26350	28210	30080	
			90	29010	32460	36070	39840	43760	47800	51950	56200	
	HGZC0400UWJ300N	114N3617	95	27590	30880	34320	37910	41630	45480	49430	53470	
	HGZC0400UWJ300Q	114N3618	100	26140	29270	32540	35950	39480	43130	46880	50710	8.27
	HGZC0400UWJ300R	114N3619	105	24670	27630	30730	33960	37310	40760	44310	47940	
			110	23170	25970	28900	31960	35120	38380	41730	45160	
			90	35840	39770	43850	48080	52420	56870	61400	65990	
	HGZC0500UWJ300N	114N3621	95	34010	37750	41640	45660	49800	54030	58340	62710	8.19
	HGZC0500UWJ300Q	114N3622	100	32160	35730	39430	43240	47170	51180	55270	59410	8.19
	HGZC0500UWJ300R	114N3623	105	30320	33690	37200	40820	44530	48330	52200	56120	8.11
			110	28460	31660	34970	38390	41900	45490	49140	52830	
			90	45880	50630	55570	60700	65990	71430	76990	82650	
	HGZC0700UWJ300Q	114N3626	95	43730	48250	52960	57840	62870	68030	73310	78680	8.01
	HGZC0700UWJ300R	114N3627	100	41550	45840	50310	54930	59700	64600	69590	74670	7.94
			105	39330	43390	47620	52000	56500	61130	65850	70640	
			110	37070	40910	44900	49030	53280	57640	62080	66600	
			90	58530	65320	72470	79950	87760	95870	104200	112900	
	HGZC0900UWJ300Q	114N3628	95	55620	62090	68900	76030	83460	91170	99140	107300	
	HGZC0900UWJ300R	114N3629	100	52700	58850	65320	72100	79150	86470	94040	101800	8.80
			105	49770	55610	61740	68160	74850	81780	88940	96310	
			110	46820	52360	58160	64230	70550	77100	83870	90820	
			90	72590	80820	89440	98420	107700	117400	127300	137400	
	HGZC1000UWJ300Q	114N3631	95	68910	76760	84970	93530	102400	111600	121000	130600	
	HGZC1000UWJ300R	114N3632	100	65210	72680	80490	88630	97060	105800	114700	123800	8.75
			105	61510	68590	76000	83710	91700	99950	108400	117100	
			110	57790	64490	71500	78800	86350	94150	102200	110300	
			90	81990	90110	98610	107500	116600	126100	135800	145800	
	HGZC1200UWJ300Q	114N3633	95	77940	85700	93810	102300	111000	120100	129400	138900	
	HGZC1200UWJ300R	114N3634	100	73890	81280	89010	97060	105400	114000	122900	132000	8.51
			105	69850	76870	84210	91860	99800	108000	116400	125000	
			110	65810	72470	79430	86680	94210	102000	110000	118200	
			90	91250	100200	109400	119000	129000	139200	149600	160300	
	HGZC1350UWJ300Q	114N3636	95	86730	95220	104100	113200	122600	132400	142400	152500	
	HGZC1350UWJ300R	114N3637	100	82200	90280	98690	107400	116400	125600	135100	144700	8.19
			105	77670	85340	93400	101600	110100	118900	127800	136900	
			110	73140	80400	87960	95790	103900	112100	120600	129200	

¹ Ambient temperature = 90 °F, Return gas = 65 °F, Subcooling = 5 °F

Full range of models (refrigerants, capacities, and voltages codes), spare parts, and more available at <https://bit.ly/CUCatalogNAM>.

Check Coolselector or contact Danfoss.

Optyma™ - Condensing Units (5/5)

R-404A LBP/ R-507 LBP			Ambient temperature (°F)	Capacity range in btu/h at evaporating temperature (°F)										AWEF rating	
Competitor Model Nos.	Danfoss Model No.	Danfoss Code No.		-40	-35	-30	-25	-20	-15	-10	-5	0	5		10
	UCHC0020RWA000B	114N2316	90	350	400	450	550	600	700	800	900	1000	1100	1250	N/A
			95	300	350	450	500	550	650	750	850	950	1050	1200	
			100	300	350	400	450	550	600	700	800	900	1000	1100	
			110	250	300	350	400	500	550	650	700	800	900		
AEA2410	UCHC0025RWB000B	114N2318	90	600	700	800	900	1050	1200	1350	1500	1650	1850	2050	N/A
			95	550	650	750	900	1000	1150	1250	1400	1600	1750	1950	
			100	550	600	700	850	950	1050	1200	1350	1500	1650	1850	
			110	450	550	650	750	850	950	1100	1250	1350	1550	1700	
AEA2413 M4FL0033	UCHC0033RWC000B	114N2321	90	750	850	1000	1100	1300	1450	1650	1800	2050	2250	2500	N/A
			95	700	800	950	1050	1200	1400	1550	1750	1950	2150	2400	
			100	650	750	850	1000	1150	1300	1450	1650	1850	2050	2250	
AKA2422 M4FL0040	UCHC0050UWC000B	114N2324	90			1100	1300	1500	1700	1900	2150	2400	2700	2950	N/A
			95			1000	1200	1400	1600	1850	2050	2300	2550	2850	
	UCHC0050UWC000N	114N2325	100			900	1100	1300	1500	1750	1950	2200	2450	2700	
			110			750	950	1150	1350	1550	1750	2000	2250	2500	
	LCHC0050RWB000B	114N2389	90	1050	1250	1450	1700	1950	2200	2500	2800	3150	3450	3850	
			95	950	1150	1350	1600	1850	2100	2400	2650	3000	3300	3650	
			100	850	1050	1250	1500	1700	2000	2250	2500	2800	3150	3450	
			110	700	900	1100	1300	1500	1750	2000	2300	2550	2850	3150	
AJA2429	LCHC0060UWC000B	114N2335	90	1350	1550	1850	2100	2400	2700	3050	3400	3800	4200	4600	N/A
			95	1250	1450	1700	1950	2250	2550	2900	3200	3600	3950	4350	
			100	1150	1350	1600	1850	2100	2400	2700	3050	3400	3750	4100	
				950	1150	1400	1600	1850	2150	2400	2700	3050	3350		
M4FL0067 FJFA075	LCHC0075UWC000B	114N2337	90	1450	1800	2150	2550	2950	3400	3900	4400	4950	5550	6200	N/A
	LCHC0075UWC000N	114N2338	95	1400	1750	2100	2450	2900	3350	3800	4300	4850	5450	6100	
	100		1650	2000	2400	2800	3250	3750	4250	4800	5350	6000			
AWA2448 FJALA100 FJALA101 FJALA103 FJALA102	LCHC0100UWD000N	114N2339	90	1700	2250	2800	3400	4000	4650	5350	6000	6800	7550	8400	N/A
			95	1550	2100	2650	3200	3850	4500	5150	5850	6600	7400	8250	
			100		1900	2500	3050	3650	4300	5000	5700	6450	7250	8100	
			110						4000	4700	5400	6150	7000		
	LCHC0150UWF000N	114N6725	90	2911	3625	4394	5214	6082	6993	7944	8929				6.81 6.63
	LCHC0150UWF000Q	114N6726	95	2657	3342	4076	4858	5683	6547	7447	8378				
	LCZB0150UWF000R	114N6727	100	2405	3060	3761	4504	5286	6104	6954	7831				
			105		2781	3448	4153	4893	5664	6464	7288				
			110			3138	3805	4503	5228	5979	6750				
AWA2479 AWA2490 AVA2510 FJALB200 FJALA225	LCHC0200UWF000N	114N6729	90	4571	5324	6147	7041	8004	9036	10130	11290				3.61 3.50 3.51
	LCHC0200UWF000Q	114N6730	95	4227	4943	5724	6572	7486	8465	9505	10600				
	LCHC0200UWF000R	114N6731	100	3898	4579	5320	6122	6987	7913	8898	9938				
			105		4230	4932	5690	6507	7381	8310	9292				
			110			4559	5275	6044	6866	7741	8665				
AVA2512 AVA2515 VJAL025V FJALB301 VJAL035Z	LCHC0300UWF300N	114N6733	90	5850	7248	8720	10240	11800	13360	14910	16420				3.19
	LCHC0300UWF300Q	114N6734	95	5375	6708	8104	9544	11010	12470	13920	15320				
	LCZB0300UWF300R	114N6735	100	4889	6158	7480	8837	10210	11580	12920	14220				
			105		5601	6849	8124	9406	10680	11920	13120				
			110			6213	7406	8600	9777	10920	12020				
VJAL040Z VJAL050Z	LCHC0400UWF000N	114N6737	90	9106	11160	13370	15740	18250	20910	23700	26610				3.29
	LGHC0400UWF000Q	114N6738	95	8364	10340	12470	14740	17150	19690	22350	25120				
	LGHC0400UWF000R	114N6739	100	7626	9529	11570	13750	16050	18470	21000	23640				
			105		8723	10680	12750	14950	17250	19660	22150				
CJDL0600	LGHC0600UWF000Q LGHC0600UWF000R	114N6741 114N6742	90	14890	17940	21250	24820	28630	32690	36990	41500				3.66 3.63
			95	13630	16570	19760	23180	26830	30700	34800	39090				
			100	12340	15170	18230	21500	24980	28670	32560	36640				
			105		13750	16670	19790	23110	26610	30300	34160				
			110			15100	18060	21210	24530	28020	31660				
CPDK0600	LGHC0750UWF000Q LGHC0750UWF000R	114N6744 114N6745	90	20210	24010	28100	32460	37070	41920	46960	52180				3.47 3.45
			95	18820	22450	26350	30500	34880	39470	44230	49160				
			100	17400	20870	24580	28520	32660	36990	41480	46110				
			105		19280	22800	26520	30430	34500	38710	43050				
		110			21010	24510	28180	31990	35930	39980					

¹ Ambient temperature = 90 °F, Return gas = 65 °F, Subcooling = 5 °F

Full range of models (refrigerants, capacities, and voltages codes), spare parts, and more available at <https://bit.ly/CUCatalogNAM>.

Check Coolselector or contact Danfoss.

Optyma™ Slim - Low Ambient Outdoor Condensing Units

The Danfoss Optyma™ Slim line of low ambient condensing units range in size from 1 to 10 hp for low and medium temperature applications for R-404A, R-448A, and R-449A. With a contractor-friendly, open design the Optyma Slim is easy to install and service. Equipped with high quality components, it provides reliable and efficient performance. Equipped with variable speed fan, condenser pressure regulation, and hot gas injection to receiver; allows reliable operation during low ambient temperatures.

Low ambient model utilizes the following components* to allow operation in cold winter climates:

- Head pressure valve
- Heated and insulated liquid receiver
- Variable speed condenser fan
- Thermostat for receiver heat control

*In addition to standard Optyma Slim components

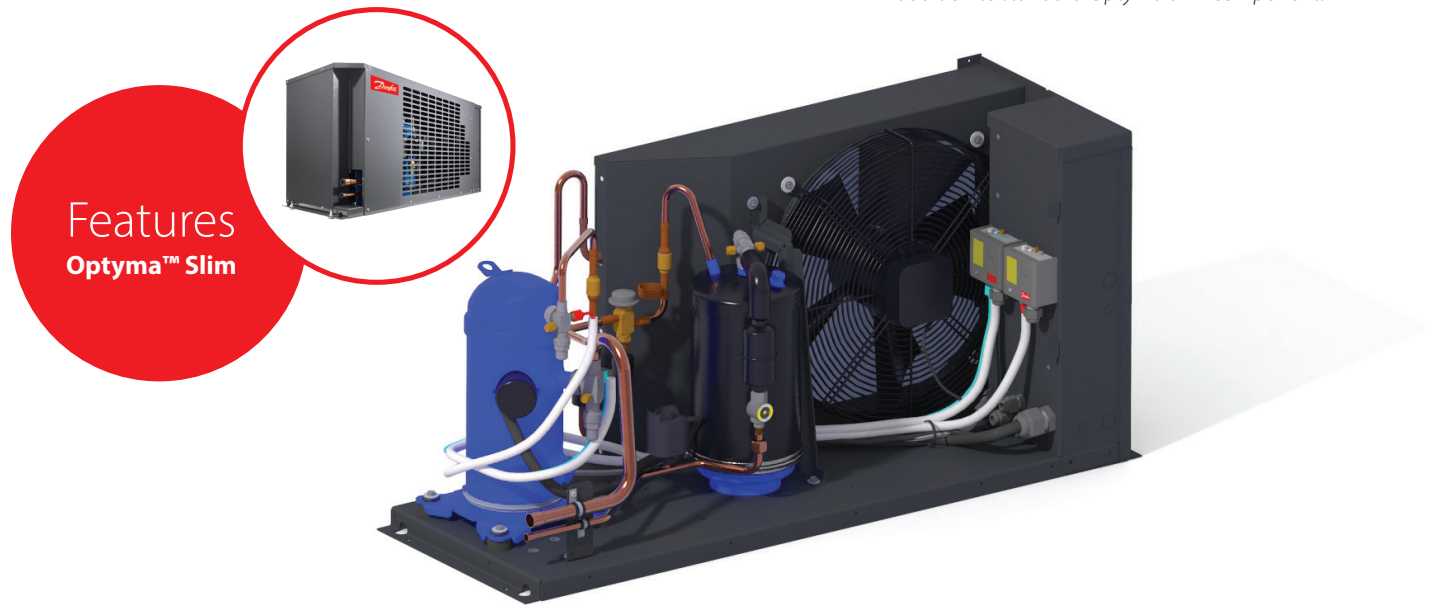

Nomenclature / Model No.

Application	Design	Refrigerant	Condenser size	HP rating	Certification	Version	Electrical code
H	N	X	M	0300	U	WG000	Q

Application:

- L: Low
- H: High or Medium / High
- M: Medium or Low/Medium
- U: Universal Low / Medium / High

Design:

- C: Air cooled condenser, Single fan, Recip
- J: Air cooled condenser, Slim Design, Recip
- G: Air cooled condenser, Twin fan, Recip
- N: Air cooled condenser, Slim Design, Scroll
- R: Air cooled condenser, Twin fan, Scroll

Refrigerant:

- G: R134a
- H: R404A/R507/R452A
- M: R22 Replacement
- N: R290
- Z: R404A/R507A/R134a/R448A/R449A/R452A*
- X: R448A/R449A/R404A/R507A/R134a/R452A*
- Y: R448A/R449A/R404A/R507A/R452A S: R410A/R454B

Condenser size:

- C: Fin and Tube condenser size 110F ambient
- M: Microchannel Condenser size 115F ambient

HP rating:

HP rating in hundredths of HP, i.e.: 0033=1/3 HP, 1000 = 10 HP

Certification:

- R: UL Recognized
- U: UL Listed

Electrical code:

- B: Compressor & fan(s), 115V, 1ph, 60 Hz
- N: Compressor & fan(s), 230V, 1ph, 60 Hz
- Q: Compressor 208-230V, 3ph, 60 Hz Fan(s) 230V, 1ph, 60 Hz
- R: Compressor 460V, 3ph, 60 Hz Fan(s) 460V, 1ph, 60 Hz

Version:

- DF: Plastic baseplate
- WA: Power cord
- WB: Power cord, Receiver
- WC: Electrical box, Receiver
- WD: Electrical box, Receiver, Low pressure control
- WE: Electrical box, Receiver, Dual pressure control, Fan cycling control, larger than 3HP dual fan units use KPU fan cycling control
- WF: WE + Filter drier, Sight glass, Solenoid valve with coil
- WG: BX, Receiver, Dual pressure control, Fan speed controller or Fan cycling, Defrost Timer, Outdoor enclosure (MBP)
- WH: Electrical box, Receiver, Dual pressure control, Fan speed controller or Fan cycling, Defrost timer, Outdoor enclosure, Suction Accumulator (LBP)
- WJ: Electrical box, Receiver, Dual pressure control, Fan cycling control, Filter drier, Sight glass
- WK: WG + Low Ambient Temperature
- WL: WH + Low Ambient Temperature

* R134a is only available in MBP units without low-ambient kit

Rating Conditions (ARI)		
Application	LBP	MBP/HBP
Ambient Temp	90°F	90°F
Return Gas	40°F	65°F
SubCooling	5°F	5°F



Scan the QR Code for Outdoor Units without low-ambient kit

Optyma™ Slim condensing unit R448A/R449A - MBP

Fan	Model no	Version	Electrical code	Code no	Compressor model	Amb. temp.	Capacity range in (btu/hr) at evaporating temperature						Power consumption [W] at evap. temp. 25 F	Power consumption [W] at evap. temp. 20 F	AWEF*	
						°F	10	15	20	25	30	35				40
Single fan	HJZM0150	WK	N Q	114N3575 114N3576	MTZ18	90	7668	8819	10040	11330	12680	14100	15590	1705	1629	8.19
						95	7224	8330	9503	10740	12040	13410	14830			
						100	6791	7852	8978	10170	11420	12720	14090			
						110	-	6929	7960	9049	10190	11390	12640			
						115	-	6484	7469	8508	9599	10740	11930			
	HNXM0200	WK	N Q	114N3577 114N3578	MLZ15	90	12910	14400	15990	17690	19490	21400	23430	2408	2357	8.44 8.77
						95	12460	13900	15430	17070	18810	20650	22610			
						100	12010	13390	14870	16450	18120	19900	21780			
						110	-	12370	13730	15190	16730	18370	20110			
						115	-	11850	13160	14550	16030	17600	19270			
	HNXM0250	WK	N Q	114N3581 114N3582	MLZ19	90	16790	18660	20650	22770	25020	27390	29900	3013	2944	8.79 9.19
						95	16240	18040	19960	22000	24170	26460	28870			
						100	15690	17420	19260	21230	23310	25510	27830			
						110	-	16140	17840	19640	21560	23580	25730			
						115	-	15480	17110	18840	20670	22610	24660			
	HNXM0300	WK	N Q	114N3579 114N3580	MLZ21	90	17760	19770	21910	24180	26580	29120	31800	3174	3097	8.92 9.24
						95	17130	19070	21130	23320	25630	28080	30660			
						100	16490	18360	20340	22440	24670	27030	29510			
						110	-	16900	18730	20660	22710	24880	27170			
						115	-	16160	17900	19750	21710	23790	25980			
HNXM0350	WK	N Q	114N3583 114N3584	MLZ26	90	22170	24600	27190	29960	32890	35990	39270	3826	3730	9.22 9.87	
					95	21400	23740	26230	28890	31700	34690	37840				
					100	20620	22860	25250	27800	30500	33360	36390				
					110	-	21060	23240	25560	28030	30650	33420				
					115	-	20140	22210	24420	26770	29260	31900				
HNXM0400	WK	N Q	114N3585 114N3586	MLZ30	90	26300	29140	32180	35420	38860	42510	46370	4455	4336	9.40 9.80	
					95	25260	28000	30920	34040	37360	40890	44610				
					100	24200	26830	29640	32640	35830	39220	42810				
					110	-	24410	26980	29730	32670	35800	39110				
					115	-	23180	25620	28240	31040	34030	37210				

Test condition

Return gas temperature 65°F
Subcooling 5°F

Electrical code

N: Compressor & fan(s) 230V, 1 ph, 60 Hz
Q: Compressor 208-230V, 3ph, 60 Hz
Fan(s) 230V, 1ph, 60 Hz

Version

WG: Electrical box, Receiver, Dual pressure control, Fan speed controller or Fan cycling, Defrost Timer, Outdoor enclosure (MBP)
WK: WG + Low Ambient Kit

HP rating in hundredths of HP, i.e.: 033=1/3hp, (UCGC0100U:0100=1hp)

Power consumption referred at 90°F ambient temperature

*This refrigeration system is designed and certified for use in walk-in cooler applications

R448A and R449A performance data are nearly identical

Performance data is based on fan full speed

All Optyma Slim Condensing units are UL Listed

Optyma™ Slim condensing unit R448A/R449A - MBP

Fan	Model no	Version	Electrical code	Code no	Compressor model	Amb. temp.	Capacity range in (btu/hr) at evaporating temperature							Power consumption [W] at evap. temp. 25 F	Power consumption [W] at evap. temp. 20 F	AWEF*
						°F	10	15	20	25	30	35	40			
Two fan	HNXM0500	WK	N Q	114N3587 114N3588	MLZ38	90	31640	35200	39050	43210	47670	52450	57540	5406	5301	9.06 9.58
						95	30560	33980	37700	41710	46020	50630	55560			
						100	29480	32760	36330	40180	44340	48790	53550			
						110	-	30290	33550	37090	40920	45040	49460			
						115	-	29050	32150	35530	39190	43140	47380			
	HRXM0600	WK	Q	114N3589	MLZ45	90	38490	42850	47520	52510	57830	63480	69460	6504	6351	9.64
						95	37070	41280	45790	50610	55760	61220	67020			
						100	35650	39700	44050	48710	53670	58950	64550			
						110	-	36520	40550	44850	49450	54360	59570			
						115	-	34920	38780	42910	47320	52040	57060			
	HRXM0700	WK	Q	114N3591	MLZ48	90	42340	47050	52070	57410	63070	69060	75370	6907	6749	9.83
						95	40720	45260	50110	55260	60720	66490	72580			
						100	39070	43440	48100	53060	58320	63880	69750			
						110	-	39700	43980	48540	53380	58510	63930			
						115	-	37770	41860	46210	50840	55760	60960			
	HRXM0750	WK	Q	114N3592	MLZ58	90	51070	56740	62810	69310	76240	83610	91420	7665	7493	10.28
						95	49310	54780	60640	66910	73590	80710	88260			
						100	47530	52790	58430	64470	70910	77770	85060			
						110	-	48720	53920	59480	65420	71770	78510			
						115	-	46650	51620	56940	62630	68700	75180			
HRXM1000	WK	Q	114N3593	MLZ76	90	62370	69580	77310	85550	94330	103600	113500	9991	9768	9.88	
					95	59830	66820	74300	82280	90790	99810	109400				
					100	57230	63980	71210	78930	87150	95890	105200				
					110	-	58100	64800	71980	79630	87770	96420				
					115	-	55060	61490	68380	75740	83580	91920				

Test condition

Return gas temperature 65°F
Subcooling 5°F

Electrical code

N: Compressor & fan(s) 230V, 1 ph, 60 Hz
Q: Compressor 208-230V, 3ph, 60 Hz & Fan(s) 230V, 1ph, 60 Hz
R: Compressor 420-460V, 3ph, 60 Hz & Fan(s) 460V, 1ph, 60Hz

Version

WG: Electrical box, Receiver, Dual pressure control, Fan speed controller or Fan cycling, Defrost Timer, Outdoor enclosure (MBP)
WK: WG + Low Ambient Kit

HP rating in hundredths of HP, ie.: 033=1/3hp, (UCGC0100U:0100=1hp)

Power consumption referred at 90°F ambient temperature

*This refrigeration system is designed and certified for use in walk-in cooler applications

R448A and R449A performance data are nearly identical

Performance data is based on fan full speed

All Optyma Slim Condensing units are UL Listed

Optyma™ Slim condensing unit R404A/R507 - MBP

Fan	Model no	Version	Electrical code	Code no	Compressor model	Amb. temp.	Capacity range in (btu/hr) at evaporating temperature						Power consumption [W] at evap. temp. 25 F	Power consumption [W] at evap. temp. 20 F	AWEF*	
						°F	10	15	20	25	30	35				40
Single fan	HJZM0150	WK	N Q	114N3575 114N3576	MTZ18	90	9048	10350	11676	13124	14644	16232	17847	2002	1935	7.85
						95	8504	9749	11017	12399	13848	15363	16904			
						100	7957	9146	10355	11672	13052	14492	15960			
						110	-	8138	9249	10458	11723	13042	14388			
						115	-	7532	8585	9730	10927	12175	13449			
	HNXM0200	WK	N Q	114N3577 114N3578	MLZ15	90	14640	16250	17950	19740	21590	23520	25490	2359	2337	10.06 10.04
						95	13970	15520	17150	18870	20650	22490	24380			
						100	13290	14780	16340	17990	19700	21460	23260			
						110	-	13240	14680	16180	17750	19350	20990			
						115	-	12440	13820	15260	16750	18280	19850			
	HNXM0250	WK	N Q	114N3581 114N3582	MLZ19	90	19080	20970	22970	25090	27320	29670	32130	2973	2933	10.04 10.30
						95	18290	20100	22020	24040	26180	28430	30800			
						100	17490	19210	21040	22980	25030	27180	29450			
						110	-	17390	19050	20810	22670	24640	26710			
						115	-	16450	18020	19690	21470	23340	25320			
	HNXM0300	WK	N Q	114N3579 114N3580	MLZ21	90	20150	22110	24190	26400	28730	31190	33790	3187	3136	9.92 10.27
						95	19300	21180	23180	25290	27530	29890	32390			
						100	18420	20220	22140	24160	26310	28580	30970			
						110	-	18230	19980	21840	23800	25890	28090			
						115	-	17190	18860	20630	22510	24510	26630			
	HNXM0350	WK	N Q	114N3583 114N3584	MLZ26	90	25330	27850	30510	33300	36230	39270	42440	3829	3774	10.33 10.58
						95	24270	26680	29230	31910	34720	37640	40680			
						100	23170	25480	27930	30490	33180	35980	38900			
						110	-	22980	25210	27560	30020	32580	35250			
						115	-	21670	23800	26040	28390	30840	33400			
	HNXM0400	WK	N Q	114N3585 114N3586	MLZ30	90	28880	31820	34900	38120	41480	44960	48570	4596	4507	9.62 10.51
						95	27590	30400	33360	36450	39660	43010	46470			
						100	26270	28960	31790	34740	37820	41020	44340			
110						-	25990	28570	31250	34060	36970	40000				
115						-	24470	26910	29470	32140	34920	37800				

Test condition

Return gas temperature 65°F
Subcooling 5°F

Electrical code

N: Compressor & fan(s) 230V, 1 ph, 60 Hz
Q: Compressor 208-230V, 3ph, 60 Hz
Fan(s) 230V, 1ph, 60 Hz

Version

WG: Electrical box, Receiver, Dual pressure control, Fan speed controller or Fan cycling, Defrost Timer, Outdoor enclosure (MBP)
WK: WG + Low Ambient Kit

HP rating in hundredths of HP, ie.: 033=1/3hp, (UCGC0100U:0100=1hp)

Power consumption referred at 90°F ambient temperature

*This refrigeration system is designed and certified for use in walk-in cooler applications

Performance data is based on fan full speed

All Optyma Slim Condensing units are UL Listed

Optyma™ Slim condensing unit R404A/R507 - MBP

Fan	Model no	Version	Electrical code	Code no	Compressor model	Amb. temp.	Capacity range in (btu/hr) at evaporating temperature							Power consumption [W] at evap. temp. 25 F	Power consumption [W] at evap. temp. 20 F	AWEF*
						°F	10	15	20	25	30	35	40			
Two fan	HRXM0500	WK	N Q	114N3587 114N3588	MLZ38	90	35730	39530	43530	47720	52110	56690	61440	5430	5336	9.64 10.48
						95	34120	37770	41630	45690	49930	54360	58960			
						100	32480	35990	39700	43610	47700	51970	56420			
						110	-	32350	35750	39340	43110	47060	51190			
						115	-	30520	33750	37170	40770	44560	48510			
	HRXM0600	WK	Q	114N3589	MLZ45	90	43050	47300	51790	56540	61520	66740	72210	6264	6181	10.57
						95	41250	45320	49630	54180	58960	63980	69220			
						100	39410	43310	47430	51780	56360	61170	66200			
						110	-	39140	42890	46860	51040	55430	60040			
						115	-	36980	40550	44320	48310	52500	56900			
	HRXM0700	WK	Q	114N3591	MLZ48	90	46560	51140	55980	61060	66380	71930	77700	6912	6798	10.45
						95	44590	48980	53610	58470	63570	68890	74420			
						100	42570	46760	51180	55830	60700	65790	71080			
						110	-	42140	46150	50360	54790	59420	64250			
						115	-	39740	43540	47540	51750	56160	60760			
	HRXM0750	WK	Q	114N3592	MLZ58	90	56950	63010	69380	76050	83030	90340	97970	8089	7948	10.66
						95	54160	59960	66040	72410	79070	86030	93300			
						100	51290	56830	62620	68670	75010	81620	88520			
						110	-	50310	55510	60940	66610	72520	78690			
						115	-	46940	51840	56950	62280	67840	73640			
HRXM1000	WK	Q	114N3593	MLZ76	90	72760	79770	87190	95020	103300	111900	120900	10580	10380	10.3	
					95	69610	76280	83330	90760	98580	106800	115400				
					100	66390	72700	79370	86410	93800	101600	109700				
					110	-	65300	71210	77440	84000	90890	98100				
					115	-	61460	67000	72830	78970	85420	92190				

Test condition

Return gas temperature 65°F
Subcooling 5°F

Electrical code

N: Compressor & fan(s) 230V, 1 ph, 60 Hz
Q: Compressor 208-230V, 3ph, 60 Hz & Fan(s) 230V, 1ph, 60 Hz

Version

WG: Electrical box, Receiver, Dual pressure control, Fan speed controller or Fan cycling, Defrost Timer, Outdoor enclosure (MBP)
R: Compressor 420-460V, 3ph, 60 Hz & Fan(s) 460V, 1ph, 60Hz
WK: WG + Low Ambient Kit

HP rating in hundredths of HP, i.e.: 033=1/3hp, (UCGC0100U:0100=1hp)

Power consumption referred at 90°F ambient temperature

*This refrigeration system is designed and certified for use in walk-in cooler applications

Performance data is based on fan full speed

All Optyma Slim Condensing units are UL Listed

Optyma™ Slim condensing unit R452A - MBP

Fan	Model no	Version	Electrical code	Code no	Compressor model	Amb. temp.	Capacity range in (btu/hr) at evaporating temperature							Power consumption [W] at evap. temp. 25 F	Power consumption [W] at evap. temp. 20 F	AWEF*
						°F	10	15	20	25	30	35	40			
Two fan	HRXM0500	WK	N Q	114N3587 114N3588	MLZ38	90	33490	37040	40820	44840	49100	53590	58330	5617	5514	9.14 9.71
						95	32190	35580	39210	43050	47130	51440	55980			
						100	30850	34100	37560	41230	45130	49240	53580			
						110	-	31020	34150	37470	41000	44740	48690			
						115	-	29440	32390	35540	38890	42440	46190			
	HRXM0600	WK	Q	114N3589	MLZ45	90	40810	44950	49360	54040	58980	64190	69670	6647	6484	9.53
						95	39180	43130	47340	51800	56510	61490	66730			
						100	37520	41280	45270	49520	54010	58750	63750			
						110	-	37480	41060	44860	48890	53170	57680			
						115	-	35540	38900	42480	46290	50330	54610			
	HRXM0700	WK	Q	114N3591	MLZ48	90	44500	49090	53970	59130	64580	70310	76320	7246	7086	9.81
						95	42630	47020	51680	56620	61830	67320	73080			
						100	40720	44900	49350	54050	59030	64270	69780			
						110	-	40550	44550	48790	53280	58030	63050			
						115	-	38330	42090	46100	50350	54860	59620			
	HRXM0750	WK	Q	114N3592	MLZ58	90	53900	59650	65770	72280	79180	86470	94150	8415	8255	10.3
						95	51680	57210	63090	69350	75980	82990	90380			
						100	49420	54710	60350	66340	72700	79430	86520			
						110	-	49540	54670	60140	65940	72090	78600			
						115	-	46880	51750	56940	62470	68330	74550			
HRXM1000	WK	Q	114N3593	MLZ76	90	67150	74200	81650	89500	97760	106400	115500	10420	10220	9.95	
					95	64380	71130	78270	85800	93710	102000	110700				
					100	61540	68000	74820	82020	89590	97530	105800				
					110	-	61520	67700	74220	81090	88310	95890				
					115	-	58180	64040	70220	76740	83600	90810				

Test condition

Return gas temperature 65°F
Subcooling 5°F

Electrical code

N: Compressor & fan(s) 230V, 1 ph, 60 Hz
Q: Compressor 208-230V, 3ph, 60 Hz & Fan(s) 230V, 1ph, 60 Hz
R: Compressor 420-460V, 3ph, 60 Hz & Fan(s) 460V, 1ph, 60Hz

Version

WG: Electrical box, Receiver, Dual pressure control, Fan speed controller or Fan cycling, Defrost Timer, Outdoor enclosure (MBP)
WK: WG + Low Ambient Kit

HP rating in hundredths of HP, ie.: 033=1/3hp, (UCGC0100U:0100=1hp)

Power consumption referred at 90°F ambient temperature

*This refrigeration system is designed and certified for use in walk-in cooler applications

Performance data is based on fan full speed

All Optyma Slim Condensing units are UL Listed

Optyma™ Slim condensing unit R448A/R449A - LBP

	Model no	Version	Electrical code	Code no	Compressor model	Amb. temp.	Capacity range in (btu/hr) at evaporating temperature							Power consumption [W] at evap. temp. -20 F	Power consumption [W] at evap. temp. -10 F	AWEEF*	
						°F	-25	-20	-15	-10	-5	0	5				10
Single fan	LNYM0400	WL	Q	114N3594	LLZ013	90	11030	12470	14030	15720	17550	19500	21590	23820	3268	3563	3.41
						95	-	12090	13590	15220	16970	18850	20850	22980			
						100	-	-	13140	14700	16380	18180	20100	22140			
						105	-	-	-	14170	15770	17490	19330	21270			
						110	-	-	-	-	15150	16790	18540	20400			
	LNYM0500	WL	Q	114N3595	LLZ015	90	13550	15280	17170	19210	21420	23800	26350	29070	3981	4297	3.48
						95	-	14850	16660	18620	20730	23000	25430	28020			
						100	-	-	16140	18010	20020	22180	24500	26960			
						105	-	-	-	17380	19300	21350	23550	25890			
	LNYM0600	WL	Q	114N3596	LLZ018	90	15080	17030	19150	21440	23920	26570	29400	32420	4954	5385	3.26
						95	-	16410	18440	20630	22990	25520	28220	31090			
						100	-	-	17700	19780	22030	24440	27010	29740			
105						-	-	-	18900	21030	23320	25750	28340				
Two fan	LRYM0800	WL	Q	114N3597	LLZ024	90	20000	22510	25230	28170	31330	34730	38350	42200	5683	6222	3.39
						95	-	21860	24480	27310	30340	33590	37060	40750			
						100	-	-	23700	26410	29320	32430	35750	39270			
						105	-	-	-	25470	28250	31220	34390	37750			
							-	-	-	-	27140	29970	32980	36180			

Test condition

Return gas temperature 40°F
Subcooling 5°F

Electrical code

N: Compressor & fan(s) 230V, 1 ph, 60 Hz
Q: Compressor 208-230V, 3ph, 60 Hz & Fan(s) 230V, 1ph, 60 Hz
R: Compressor 420-460V, 3ph, 60 Hz & Fan(s) 460V, 1ph, 60Hz

Version

WH: Electrical box, Receiver, Dual pressure control, Fan speed controller or Fan cycling, Defrost Timer, Outdoor enclosure, Suction Accumulator (LBP)
WL: WH+Low Ambient Kit

HP rating in hundredths of HP, ie.: 033=1/3hp, (UCGC0100U:0100=1hp)

Power consumption referred at 90°F ambient temperature

Performance data is based on fan full speed

All Optyma Slim Condensing units are UL Listed

Optyma™ Slim condensing unit R404A/R507 - LBP

Fan	Model no	Version	Electrical code	Code no	Compressor model	Amb. temp.	Capacity range in (btu/hr) at evaporating temperature							Power consumption [W] at evap. temp. -20 F	Power consumption [W] at evap. temp. -10 F	AWEF*	
						°F	-25	-20	-15	-10	-5	0	5				10
Single fan	LNYM0400	WL	Q	114N3594	LLZ013	90	13650	15330	17130	19030	21050	23190	25440	27810	3405	3672	3.81
						95	-	14750	16460	18280	20200	22230	24370	26610			
						100	-	-	15780	17510	19330	21250	23270	25390			
						105	-	-	-	16720	18440	20250	22160	24150			
						110	-	-	-	-	17530	19230	21020	22880			
Two fan	LRYM0800	WL	Q	114N3597	LLZ024	90	24780	27840	31150	34720	38560	42650	47010	51640	5852	6360	3.76
						95	-	26780	29940	33350	37000	40890	45040	49440			
						100	-	-	28710	31950	35410	39110	43040	47210			
						105	-	-	-	30510	33800	37300	41020	44960			
						110	-	-	-	-	32150	35450	38960	42670			

Test condition

Return gas temperature 40°F
Subcooling 5°F

Electrical code

N: Compressor & fan(s) 230V, 1 ph, 60 Hz
Q: Compressor 208-230V, 3ph, 60 Hz & Fan(s) 230V, 1ph, 60 Hz
R: Compressor 420-460V, 3ph, 60 Hz & Fan(s) 460V, 1ph, 60Hz

Version

WH: BX, Receiver, Dual pressure control, Fan speed controller or Fan cycling, Defrost Timer, Outdoor enclosure, Suction Accumulator (LBP)
WL: WH+Low Ambient Kit

HP rating in hundredths of HP, ie.: 033=1/3hp, (UCGC0100U:0100=1hp)
Power consumption referred at 90°F ambient temperature
Performance data is based on fan full speed

All Optyma Slim Condensing units are UL Listed

MT/MTZ - Medium/High Temperature Reciprocating Compressors

Known for their legendary durability, Maneurop® reciprocating compressors from Danfoss cover a wide range of operating conditions. Maneurop MT and MTZ series hermetic reciprocating compressors are designed for high and medium temperature applications. These compressors have a large internal free volume that protects against the risk of liquid hammering when liquid refrigerant enters the compressor.



Nomenclature / Model No.

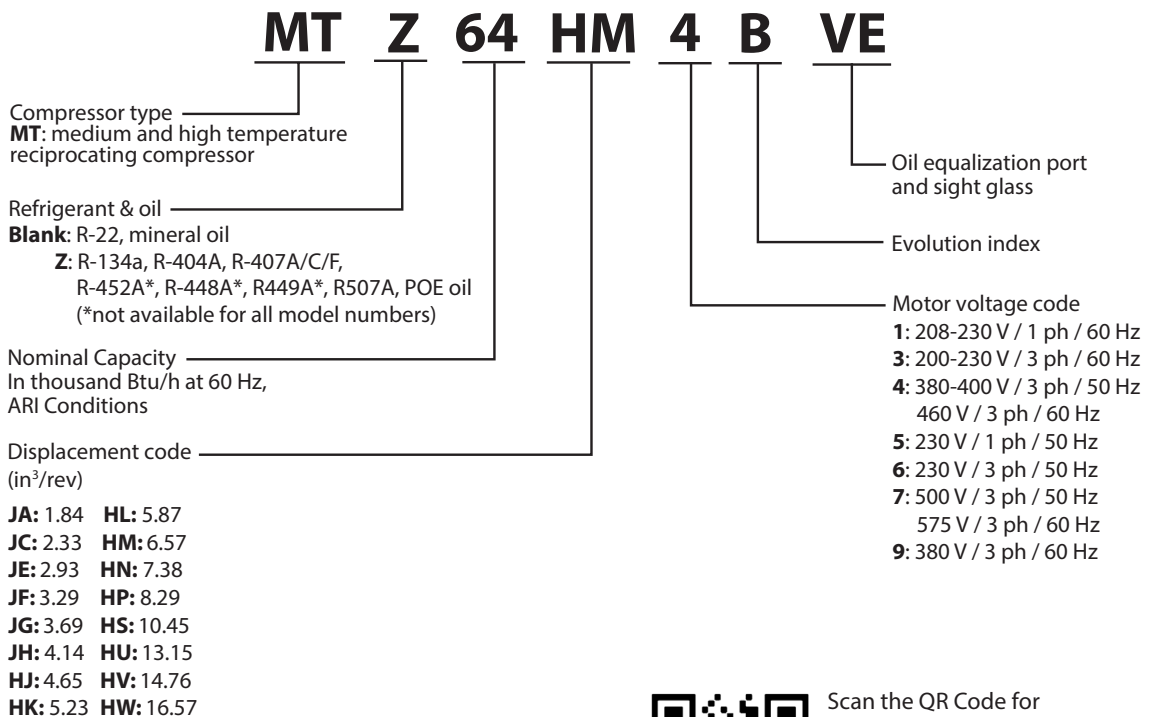

Scan the QR Code for a video on interpreting Maneurop® Nomenclature.

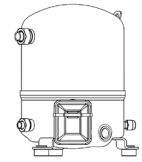

Technical data and ordering

MT/MTZ -Medium/High Temperature Reciprocating Compressors

Nominal capacity (Btu/h) ²				Connection type Rotolock (in.)	Connection with supplied sleeve (in. ODF)	No. of cylinders	Weight (lbs.)	208-230/1/60		200-230/3/60		460/3/60	
R-22 ³	R-134a ³	R-404A ⁴	R-448A					Danfoss Model No. ¹	Danfoss Code No.	Danfoss Model No. ¹	Danfoss Code No.	Danfoss Model No. ¹	Danfoss Code No.
15903				1 x 1	1/2 x 3/8	1	46	MT18JA1*VE	MT18-1VI	MT18JA3*VE	MT18-3VI	MT18JA4*VE	MT18-4VI
21975				1 x 1 ⁽⁵⁾	1/2 x 3/8 ⁽⁵⁾	1	46	MT22JC1*VE	MT22-1VI⁵	MT22JC3*VE	MT22-3VI	MT22JC4*VE	MT22-4VI
30231				1 x 1 ⁽⁵⁾	1/2 x 3/8 ⁽⁵⁾	1	51	MT28JE1*VE	MT28-1VI⁵	MT28JE3*VE	MT28-3VI	MT28JE4*VE	MT28-4VI
33044				1 1/4 x 1	5/8 x 1/2	1	53	MT32JF1*VE	MT32-1VI	MT32JF3*VE	MT32-3VI	MT32JF4*VE	MT32-4VI
37992				1 1/4 x 1	5/8 x 1/2	1	55	MT36JG1*VE	MT36-1VI	MT36JG3*VE	MT36-3VI	MT36JG4*VE	MT36-4VI
42930				1 1/4 x 1	5/8 x 1/2	1	57	MT40JH1*VE	MT40-1VI	MT40JH3*VE	MT40-3VI	MT40JH4*VE	MT40-4VI
43999				1 3/4 x 1 1/4	7/8 x 3/4	2	82	MT44HJ1*VE	MT44-1VI	MT44HJ3*VE	MT44-3VI	MT44HJ4*VE	MT44-4VI
50160				1 3/4 x 1 1/4	7/8 x 3/4	2	82	MT50HK1*VE	MT50-1VI	MT50HK3*VE	MT50-3VI	MT50HK4*VE	MT50-4VI
56420				1 3/4 x 1 1/4	7/8 x 3/4	2	86	MT56HL1*VE	MT56-1VI	MT56HL3*VE	MT56-3VI	MT56HL4*VE	MT56-4VI
64366				1 3/4 x 1 1/4	7/8 x 3/4	2	86	MT64HM1*VE	MT64-1VI	MT64HM3*VE	MT64-3VI	MT64HM4*VE	MT64-4VI
74561				1 3/4 x 1 1/4	7/8 x 3/4	2	88			MT72HN3*VE	MT72-3VI	MT72HN4*VE	MT72-4VI
84977				1 3/4 x 1 1/4	1 1/8 x 3/4	2	88			MT80HP3*VE	MT80-3VI	MT80HP4*VE	MT80-4VI
95898				1 3/4 x 1 1/4	1 1/8 x 3/4	4	132			MT100HS3*VE	MT100-3VI	MT100HS4*VE	MT100-4VI
124678				1 3/4 x 1 1/4	1 1/8 x 3/4	4	141			MT125HU3*VE	MT125-3VI	MT125HU4*VE	MT125-4VI
140697				1 3/4 x 1 1/4	1 1/8 x 3/4	4	148			MT144HV3*VE	MT144-3VI	MT144HV4*VE	MT144-4VI
156820				1 3/4 x 1 1/4	1 1/8 x 3/4	4	152			MT160HW3*VE	MT160-3VI	MT160HW4*VE	MT160-4VI
11200	8980	8980		1 x 1	1/2 x 3/8	1	46	MTZ18JA1*VE	MTZ18-1VI	MTZ18JA3*VE	MTZ18-3VI	MTZ18JA4*VE	MTZ18-4VI
14849	12306	12306		1 x 1 ⁽⁵⁾	1/2 x 3/8 ⁽⁵⁾	1	46	MTZ22JC1*VE	MTZ22-1VI⁵	MTZ22JC3*VE	MTZ22-3VI	MTZ22JC4*VE	MTZ22-4VI
19276	15986	15986		1 x 1 ⁽⁵⁾	1/2 x 3/8 ⁽⁵⁾	1	51	MTZ28JE1*VE	MTZ28-1VI⁵	MTZ28JE3*VE	MTZ28-3VI	MTZ28JE4*VE	MTZ28-4VI
20949	17480	17480		1 1/4 x 1	5/8 x 1/2	1	53	MTZ32JF1*VE	MTZ32-1VI	MTZ32JF3*VE	MTZ32-3VI	MTZ32JF4*VE	MTZ32-4VI
24482	20189	20189		1 1/4 x 1	5/8 x 1/2	1	55	MTZ36JG1*VE	MTZ36-1VI	MTZ36JG3*VE	MTZ36-3VI	MTZ36JG4*VE	MTZ36-4VI
27864	23031	23031		1 1/4 x 1	5/8 x 1/2	1	57	MTZ40JH1*VE	MTZ40-1VI	MTZ40JH3*VE	MTZ40-3VI	MTZ40JH4*VE	MTZ40-4VI
30110	24323	24323		1 3/4 x 1 1/4	7/8 x 3/4	2	82	MTZ44HJ1*VE	MTZ44-1VI	MTZ44HJ3*VE	MTZ44-3VI	MTZ44HJ4*VE	MTZ44-4VI
34538	28590	28590		1 3/4 x 1 1/4	7/8 x 3/4	2	82	MTZ50HK1*VE	MTZ50-1VI	MTZ50HK3*VE	MTZ50-3VI	MTZ50HK4*VE	MTZ50-4VI
38881	32451	32451		1 3/4 x 1 1/4	7/8 x 3/4	2	86					MTZ56HL4*VE	MTZ56-4VI
44404	36056	36056		1 3/4 x 1 1/4	7/8 x 3/4	2	86	MTZ64HM1*VE	MTZ64-1VI	MTZ64HM3*VE	MTZ64-3VI	MTZ64HM4*VE	MTZ64-4VI
50000	40894	40894		1 3/4 x 1 1/4	7/8 x 3/4	2	88			MTZ72HN3*VE	MTZ72-3VI	MTZ72HN4*VE	MTZ72-4VI
56336	46521	46521		1 3/4 x 1 1/4	1 1/8 x 3/4	2	88			MTZ80HP3*VE	MTZ80-3VI	MTZ80HP4*VE	MTZ80-4VI
63963	52953	52953		1 3/4 x 1 1/4	1 1/8 x 3/4	4	132			MTZ100HS3*VE	MTZ100-3VI	MTZ100HS4*VE	MTZ100-4VI
78906	68297	68297		1 3/4 x 1 1/4	1 1/8 x 3/4	4	141			MTZ125HU3*VE	MTZ125-3VI	MTZ125HU4*VE	MTZ125-4VI
96936	80472	80472		1 3/4 x 1 1/4	1 1/8 x 3/4	4	148			MTZ144HV3*VE	MTZ144-3VI	MTZ144HV4*VE	MTZ144-4VI
107631	87421	87421		1 3/4 x 1 1/4	1 1/8 x 3/4	4	152			MTZ160HW3*VE	MTZ160-3VI	MTZ160HW4*VE	MTZ160-4VI

¹ These compressor models have threaded sight glass and 3/8 in. flare oil equalization line.

² To determine the nominal capacity for R-407A/C/F, R-452A, R-448A, R-449A, check Coolselector.

³ Evaporator temperature = 45 °F, condensing temperature = 130 °F, superheat = 20 °F, subcooling = 15 °F

⁴ Evaporator temperature = 20 °F, condensing temperature = 120 °F, superheat = 20 °F, subcooling = 0 °F

⁵ Actual connection for MT and MTZ 22-28 (208-230/1/60) is rotolock 1 1/4 in. x 1 in. and connection with supplied sleeve is 5/8 in. x 1/2 in. ODF. Capacitor values and relays for 1 phase compressors are available on page 80.

Spare Parts and Accessories

Description	Type(s) applied to	Danfoss Code No.
Belt type crankcase heater; 54W, 230V	MT(Z) 018–040	7773106
Belt type crankcase heater; 65W, 110V		7773109
Belt type crankcase heater; 65W, 230V		7773107
Belt type crankcase heater; 65W, 400V	MT(Z) 044–081	7773117
Belt type crankcase heater; 65W, 460V		120Z0466
Belt type crankcase heater; 75W, 110V		7773110
Belt type crankcase heater; 75W, 230V		7773108
Belt type crankcase heater; 75W, 400V	MT(Z) 100–160	7773118
Belt type crankcase heater; 75W, 460V		120Z0464
PTC heater	all	120Z0459
Mounting kit 1 cyl high	MT(Z) 22–28 for 208–230/1/60; 32–40 for 200–230/3/60 and 460/3/60	8156001
Mounting kit 1 cyl low	MT(Z) 18 for 208–230/1/60; 22–28 for 200–230/3/60 and 460/3/60	120Z0760
Mounting kit 2 cyl HP	MT(Z) 80 for 200–230/3/60	120Z0761
Mounting kit 2 cyl except HP	MT(Z) 50–60 for 208–230/1/60	120Z0762
Mounting kit 2 cyl	MT(Z) 44 for 208–230/1/60; 4–72 for 200–230/3/60 and 460/3/60	120Z0763
Mounting kit 2 cyl HP	MT(Z) 80 for 460/3/60	120Z0764
Mounting kit—4 cylinder compressors	MT(Z) 100–160	8156007
Mineral oil, 160P; 2 liter can	all MT	7754001
Mineral oil, 160P; 5 liter can	all MT	7754002
POE lubricant, 160PZ; 1 liter can	all MTZ	120Z0638
Oil sight glass and gasket	all	8156019
Terminal box; include cover and clamp	MT(Z) 18–44 for 208–230/1/60 18–72 for 200–230/3/60 18–80 for 460/3/60	8156134
Terminal box; include cover and clamp	MT(Z) 50–64 for 208–230/1/60 80–160 for 200–230/3/60 100–160 for 460/3/60	8156135
Blue spray paint	all	8154001
Gasket Set; 1 of each size gasket for the MT(Z) line	all—need 2 for: MT(Z)18 for 208–230 and 460 MT(Z)22–28 for 208–230/3 and 460	8156009
Rotolock Service Valve Set (no gaskets) Suction and Discharge	MT(Z)18 for 208–230 and 460 MT(Z)22–28 for 208–230/3 and 460	7703004
Rotolock Service Valve Set (no gaskets) Suction and Discharge	MT(Z) 22–40 for 208–230/1 MT(Z) 32–40 for 208–230/3 and 460	7703005
Rotolock Service Valve Set (no gaskets) Suction and Discharge	MT(Z) 44–64 for 208–230/1 MT(Z) 44–72 for 208–230/3 and 460	7703006
Rotolock Service Valve Set (no gaskets) Suction and Discharge	MT(Z) 80–160 for 208–230/3 and 460	7703009
Solder Sleeve P02 (1 ¼ in. rotolock, 1 ½ in. ODF)	Suction: MT(Z) 80–160 for 208–230/3 and 460	8153004
Solder Sleeve P06 (1 in. rotolock, ½ in. ODF)	Suction: MT(Z) 18 for 208–230/1 MT(Z) 18–28 for 208–230/3 and 460 Discharge: MT(Z) 22–40 for 208–230/1 MT(Z) 32–40 for 208–230/3 and 460	8153007
Solder Sleeve P04 (1 ¼ in. rotolock, ¾ in. ODF)	Discharge: MT(Z) 44–64 for 208–230/1 MT(Z) 44–160 for 208–230/3 and 460	8153008
Solder Sleeve P01 (1 in. rotolock, ⅝ in. ODF)	Discharge: MT(Z) 18 for 208–230/1 MT(Z) 18–28 for 208–230/3 and 460	8153010
Solder Sleeve P09 (1 ¼ in. rotolock, ⅝ in. ODF)	Suction: MT(Z) 22–40 for 208–230/1 MT(Z) 32–40 for 208–230/8 and 460	8153011
Solder Sleeve P02 (1 ¾ in. rotolock, ⅞ in. ODF)	Suction: MT(Z) 44–64 for 208–230/1 MT(Z) 44–72 for 208–230/3 and 460	8153013
Rotolock Nut, 1 in.	Suction: MT(Z) 18 for 208–230/1 MT(Z) 18–28 for 208–230/3 and 460 Discharge: MT(Z) 18–40 for 208–230/1 MT(Z) 18–40 for 208–230/3 and 460	8153122
Rotolock Nut, 1 ¼ in.	Suction: MT(Z) 22–40 for 208–230/1 MT(Z) 32–40 for 208–230/3 and 460 Discharge: MT(Z) 44–64 for 208–230/1 MT(Z) 44–160 for 208–230/3 and 460	8153123
Rotolock Nut, 1 ¾ in.	Suction: MT(Z) 44–64 for 208–230/1 MT(Z) 44–160 for 208–230/3 and 460	8153124

NTZ - Low Temperature Reciprocating Compressors

The Maneurop® NTZ series of reciprocating compressors from Danfoss Commercial Compressors are designed for low evaporating temperature applications with refrigerants R-404A, R-452A, and R-507A. The NTZ series is optimized at -30 °F with an extended evaporating temperature range from -50 °F to +15 °F. NTZ compressors have a large internal free volume that protects against the risk of liquid hammering when liquid refrigerant enters the compressor.

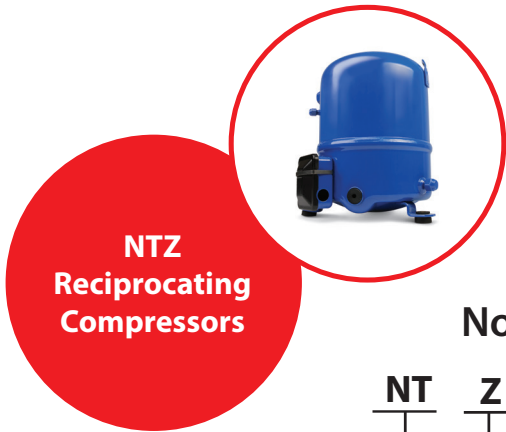

Nomenclature / Model No.

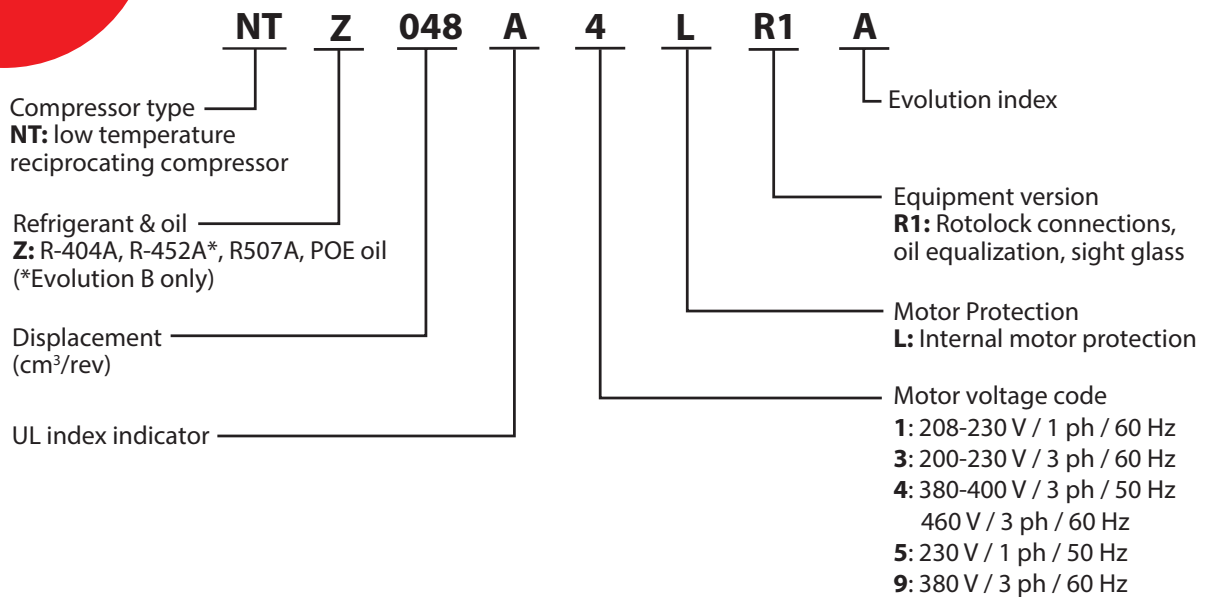

Technical data and ordering

NTZ - Low Temperature Reciprocating Compressors

Connection type Rotolock (in.)	Connection with supplied sleeve (in. ODF)	No. of cylinders	Weight (lbs.)	208-230/1/60			200-230/3/60			460/3/60		
				Danfoss Model No.	Nominal capacity ¹ (Btu/h)	Danfoss Code No. ²	Danfoss Model No.	Nominal capacity ¹ (Btu/h)	Danfoss Code No. ²	Danfoss Model No.	Nominal capacity ¹ (Btu/h)	Danfoss Code No. ²
1 ¼ × 1	¾ × ½	1	46	NTZ048A1LR1B	4547	120F0293	NTZ048A3LR1B	4490	120F0279	NTZ048A4LR1B	4490	120F0226
1 ¼ × 1	¾ × ½	1	51	NTZ068A1LR1B	6649	120F0294	NTZ068A3LR1B	7518	120F0280	NTZ068A4LR1B	7518	120F0230
1 ¾ × 1 ¼	¾ × ¾	2	77	NTZ096A1LR1B	9155	120F0295	NTZ096A3LR1B	9110	120F0281	NTZ096A4LR1B	9110	120F0234
1 ¾ × 1 ¼	¾ × ¾	2	77	NTZ108A1LR1B	10805	120F0296	NTZ108A3LR1B	10536	120F0282	NTZ108A4LR1B	10536	120F0238
1 ¾ × 1 ¼	1 ½ × ¾	2	77	NTZ136A1LR1B	10805	120F0297	NTZ136A3LR1B	13901	120F0283	NTZ136A4LR1B	13901	120F0236
1 ¾ × 1 ¼	1 ½ × ¾	4	137				NTZ215A3LR1B	21461	120F0284	NTZ215A4LR1B	21461	120F0240
1 ¾ × 1 ¼	1 ½ × ¾	4	141				NTZ271A3LR1B	29788	120F0285	NTZ271A4LR1B	29788	120F0242

¹ Evaporating temperature = -25 °F, condensing temperature = 105 °F, superheat = 20 °F, subcooling = 0 °F.

² Single compressor, threaded sight glass, ¾ in. oil equalization connection.

Capacitor values and relays for 1 phase compressors are available on page 80.

Spare Parts and Accessories

Description	Type(s) applied to	Danfoss Code No.
Belt type crankcase heater; 54W, 230V	NTZ04-068	7773106
Belt type crankcase heater; 65W, 110V	NTZ096-136	7773109
Belt type crankcase heater; 65W, 230V		7773107
Belt type crankcase heater; 65W, 400V		7773117
Belt type crankcase heater; 65W, 460V		120Z0466
Belt type crankcase heater; 75W, 110V		7773110
Belt type crankcase heater; 75W, 230V		NTZ215-271
Belt type crankcase heater; 75W, 400V	7773118	
Belt type crankcase heater; 75W, 460V	120Z0464	
PTC heater	all	120Z0459
Mounting kit 1 cyl high	NTZ048-68	8156001
Mounting kit 2 cyl HP	NTZ136 for 208-230/1/60	120Z0761
Mounting kit 2 cyl	NT096-108	120Z0763
Mounting kit 2 cyl HP	NTZ136 for 200-230/1/60 and 460/3/60	120Z0764
Mounting kit—4 cylinder compressors	NTZ215-271	8156007
Oil sight glass and gasket	all	8156019
Terminal box; include cover and clamp	NTZ048-136 (except 136-1)	8156134
Terminal box; include cover and clamp	NTZ136-1, NTZ215-271	8156135
Blue spray paint	all	8154001
Rotolock Service Valve Set (no gaskets) Suction and Discharge	NTZ048-068	7703005
Rotolock Service Valve Set (no gaskets) Suction and Discharge	NTZ096-108	7703006
Rotolock Service Valve Set (no gaskets) Suction and Discharge	NTZ136-271	7703009
Solder Sleeve P02 (1 ¼ in. rotolock, 1 ½ in. ODF)	all	8153004
Solder Sleeve P06 (1 in. rotolock, ½ in. ODF)	Discharge: all	8153007
Solder Sleeve P04 (1 ¼ in. rotolock, ¾ in. ODF)	Discharge: all	8153008
Solder Sleeve P01 (1 in. rotolock, ⅝ in. ODF)	Discharge: all	8153010
Solder Sleeve P09 (1 ¼ in. rotolock, ⅝ in. ODF)	Suction: all	8153011
Solder Sleeve P02 (1 ¾ in. rotolock, 7/8 in. ODF)	Suction:all	8153013
Rotolock Nut, 1 in.	Discharge: all	8153122
Rotolock Nut, 1 ¼ in.	Discharge: all	8153123
Rotolock Nut, 1 ¾ in.	Suction: all	8153124

H Series - Residential and Light Commercial Scroll Compressors

Danfoss Residential and Light Commercial Air Conditioning Scroll Compressors install quickly and easily and feature a design that minimizes internal parts, decreasing the overall weight and significantly reducing noise during operation. With a bolt pattern and liquid and suction line connections that line up with those of other major scroll compressor manufacturers, Danfoss scroll compressors can be used to replace compressors made by nearly any company.



Nomenclature / Model No.

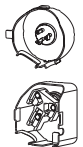
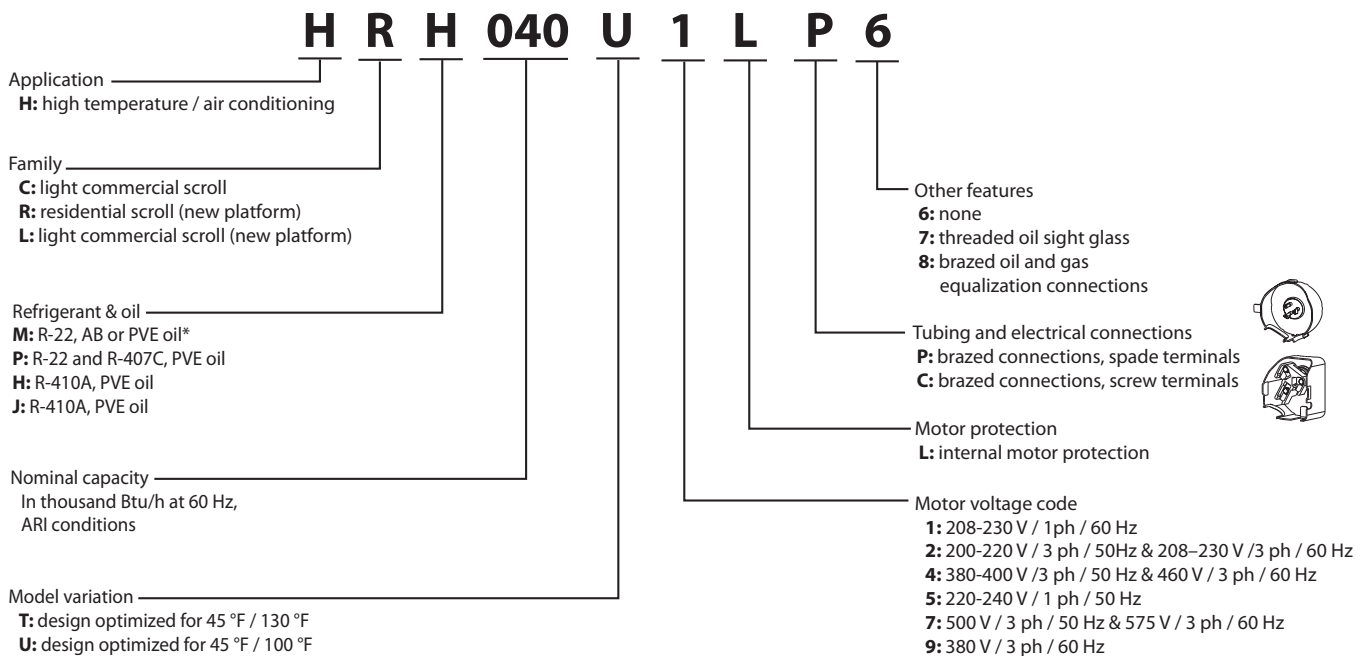

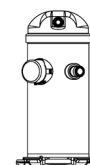

Technical data and ordering

H Series - Residential and Light Commercial Scroll Compressors (R-22/R-407C)

Refrigerant	Voltage/Phase/Frequency	Tons (approx.)	Competitor Model No.	Solder ODF connection (in.)	Weight (lbs.)	OLD Danfoss Model	NEW Danfoss Model		
							Danfoss Model No.	Danfoss Code No.	
R-22	R-407C	2	ZR25K-PFV	$\frac{3}{4} \times \frac{1}{2}$	73	HRM025T1LP6	HRP025T1LP6	121L3086	
		2 ½	ZR28K*-PFV ZR32K*-PFV	$\frac{3}{4} \times \frac{1}{2}$	75	HRM032U1LP6	HRP032U1LP6	121L3345	
		3	ZR34K*-PFV ZR36K*-PFV	$\frac{3}{4} \times \frac{1}{2}$	75	HRM038U1LP6	HRP038U1LP6	121L3353	
		3 ½	ZR40K*-PFV ZR42K*-PFV	$\frac{3}{4} \times \frac{1}{2}$	75	HRM040U1LP6 HRM042U1LP6	HRP042T1LP6	121L3094	
		4	ZR47K*-PFV	$\frac{7}{8} \times \frac{1}{2}$	77	HRM047U1LP6	HRP047U1LP6	121L3347	
		4 ½	ZR54K*-TF5	$\frac{7}{8} \times \frac{1}{2}$	97	HRM054U1LP6	HRM054U1LP6	121L3349	
		5	ZR57K*-PFV ZR61K*-PFV	$\frac{7}{8} \times \frac{1}{2}$	97	HRM060U1LP6	HRP060T1LP6	121L3070	
		2: 200-220V/3/50Hz & 208-230V/3/60Hz	3 ½	ZR42K*-TF5	$\frac{3}{4} \times \frac{1}{2}$	75	HRM042U2LP6	HRP042U2LP6	121L1106
			4	ZR47K*-TF5	$\frac{7}{8} \times \frac{1}{2}$	71	HRM047U2LP6	HRP047T2LP6	121L1126
			4 ½	ZR54K*-TF5	$\frac{7}{8} \times \frac{1}{2}$	93	HRM054U2LP6	HRP054U2LP6	121L3351
			5	ZR57K*-TF5 ZR61K*-TF5	$\frac{7}{8} \times \frac{1}{2}$	93	HRM060U2LP6	HRP060T2LP6	121L2297
			5 ½		$\frac{7}{8} \times \frac{1}{2}$	85		HLP068T2LC6	121L3276
			6	ZR72K*-TF5	$\frac{7}{8} \times \frac{1}{2}$	95	HLM072T2LC6 HLM075T2LC6	HLP075T2LC6	121L3098
			7	ZR81KC-TF5	$\frac{7}{8} \times \frac{3}{4}$	91	HLM081T2LC6	HLP081T2LC6	121L1916
			8	ZR94KC-TF5	$1 \frac{1}{8} \times \frac{7}{8}$	108	HCM094T2LC6	HCP094T2LC6	121L0906
		4: 380-415V/3/50Hz & 460V/3/60Hz	10	ZR125KC-TF5 ZR12M3*-TWC	$1 \frac{1}{8} \times \frac{7}{8}$	106	HCM120T2LC6	HCP120T2LC6	121L0766
			4	ZR47K*-TFD	$\frac{7}{8} \times \frac{1}{2}$	82	HRM047U4LP6	HRP047T4LP6	121L1046
			4 ½	ZR54K*-TFD	$\frac{7}{8} \times \frac{1}{2}$	89	HRM054U4LP6	HRP054T4LP6	121L1691
			5	ZR57K*-TFD ZR61K*-TFD	$\frac{7}{8} \times \frac{1}{2}$	88	HRM058U4LP6 HRM060U4LP6	HRP060T4LP6	121L1726
			5 ½		$\frac{7}{8} \times \frac{1}{2}$	86		HLP068T4LC6	121L2014
			6	ZR72K*-TFD	$\frac{7}{8} \times \frac{1}{2}$	58	HLM072T4LC6 HLM075T4LC6	HLP075T4LC6	121L1766
			7	ZR81KC-TFD	$\frac{7}{8} \times \frac{3}{4}$	94	HLM078T4LC6 HLM081T4LC6	HLP081T4LC6	121L1781
			8	ZR94KC-TFD	$1 \frac{1}{8} \times \frac{7}{8}$	101	HCM094T4LC6	HCP094T4LC6	121L0601
			9	ZR108KC-TFD ZR11M3-TWD	$1 \frac{1}{8} \times \frac{7}{8}$	108	HCM109T4LC6	HCP109T4LC6	121L0376
			10	ZR12M3-TWD	$1 \frac{1}{8} \times \frac{7}{8}$	109	HCM120T4LC6	HCP120T4LC6	121L0401

Additional models may be available upon request.

Full range of models (refrigerants, tons, and voltage codes) available. Check Coolselector or visit our Online Datasheet Generator at www.danfoss.com/odsg. Capacitor values and relays for 1 phase compressors are available on page 80.

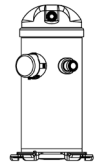

Technical data and ordering

H Series - Residential and Light Commercial Scroll Compressors (R-410A)

Refrigerant	Motor Voltage	Tons (approx.)	Competitor Model No.	Solder ODF connection (in.)	Weight (lbs.)	OLD Danfoss Model	NEW Danfoss Model	
							Danfoss Model No.	Danfoss Code No.
R-410A	1: 200-230V/1/60Hz	2 ½	ZP29K*E-PFV ZP31K*E-PFV ZP32K*E-PFV	¾ × ½	70	HRH032U1LP6	HRH032U1LP6	121L1141
		3	ZP36K*E-PFV	¾ × ½	94	HRH038U1LP6	HRH036U1LP6	121L1156
		3 ¼	ZP41K*E-PFV	7⁄8 × ½	73	HRH040U1LP6	HRH040U1LP6	121L1161
		3 ¾	ZP44K*E-PFV	7⁄8 × ½	99		HRH044U1LP6	121L1286
		4	ZP49K*E-PFV	7⁄8 × ½	79	HRH048U1LP6	HRH048U1LP6	121L2582
		4 ½	ZP51K*E-PFV	7⁄8 × ½	82		HRH051U1LP6	121L1296
		5	ZP61K*E-PFV	7⁄8 × ½	90	HLH061T1LP6	HLH061T1LP6	121L2042
	2: 200-220/3/50Hz & 208-230V/3/60Hz	3 ¼	ZP36K*E-TF5 ZP38K*E-TF5 ZP41K*E-TF5	7⁄8 × ½	77	HRH040U2LP6	HRH040U2LP6	121L1276
		3 ¾	ZP44K*E-TF5	7⁄8 × ½	89		HRH044U2LP6	121L1456
		4	ZP51K*E-TF5	7⁄8 × ½	85		HRH051U2LP6	121L1466
		5		7⁄8 × ½	90	HLH061T2LC6	HLH061T2LC6	121L2062
		5 ½	ZP67KCE-TF5	7⁄8 × ½	89	HLH068T2LC6	HLH068T2LC6	121L1481
		6	ZP72KCE-TF5	7⁄8 × ½	96	HLJ072T2LC6	HLJ072T2LC6	121L1486
		7	ZP83KCE-TF5	7⁄8 × ½	96	HLJ083T2LC6	HLJ083T2LC6	121L1491
		7 ½	ZP90KCE-TF5	1 ½ × 7⁄8	102	HCJ090T2LC6	DCJ091T2LC6	121L5003
		8 ½	ZP103KCE-TF5	1 ½ × 7⁄8	104	HCJ105T2LC6	DCJ106T2LC6	121L5011
		10	ZP120KCE-TF5	1 ½ × 7⁄8	106	HCJ120T2LC6	DCJ121T2LC6	121L5019
	4: 380-415V/3/50Hz & 460V/3/60Hz	3 ¼	ZP36K*E-TFD ZP38K*E-TFD ZP41K*E-TFD	7⁄8 × ½	77	HRH036U4LP6 HRH038U4LP6 HRH040U4LP6	HRH040U4LP6	121L1211
		3 ¾	ZP44K*E-TFD	7⁄8 × ½	77		HRH044U4LP6	121L1361
		4	ZP51K*E-TFD	7⁄8 × ½	87		HRH051U4LP6	121L1371
		5	ZP61KCE-TFD	7⁄8 × ½	96	HLH061T4LC6	HLH061T4LC6	121L2052
		5 ½	ZP67KCE-TFD	7⁄8 × ½	96	HLH068T4LC6	HLH068T4LC6	121L1391
		6	ZP72KCE-TFD	7⁄8 × ½	97	HLJ072T4LC6	HLH072T4LC6	121L1396
		7	ZP83KCE-TFD	7⁄8 × ½	93	HLJ083T4LC6	HLJ083T4LC6	121L1401
		7 ½	ZP90K*E-TFD	1 ½ × 7⁄8	109	HCJ090T4LC6	DCJ091T4LC6	121L5001
		8 ½	ZP104KCE-TFD	1 ½ × 7⁄8	109	HCJ105T4LC6	DCJ106T4LC6	121L5009
		10	ZP120K*E-TFD	1 ½ × 7⁄8	164	HCJ120T4LC6	DCJ121T4LC6	121L5017

Additional models may be available upon request.

Full range of models (refrigerants, tons, and voltage codes) available. Check Coolselector or visit our Online Datasheet Generator at www.danfoss.com/odsg.

Capacitor values and relays for 1 phase compressors are available on page 80.

Spare Parts and Accessories

Description	Type(s) applied to	Danfoss Code No.
Terminal cover, spade terminals (round)		120Z5015
Terminal cover, screw terminals (square)	all	120Z5018
Mounting kit for 1 compressor: 4 grommets, 4 sleeves, 4 bolts, 4 washers		120Z5064
PVE lubricant, 210HV (FVC68D); 1 liter can	all	120Z5034
Wire harness; 5 feet, for 200-230V scroll compressor	models with spade terminals	120Z5056
Wire harness; 5 feet, for 380-575V scroll compressor	models with spade terminals	120Z5057
Belt type crankcase heater: 40W, 230V	HRM032-047, HRH031-040	120Z0055
Belt type crankcase heater: 40W, 400V		120Z0056
Belt type crankcase heater: 50W, 230V	HRM048-060, HLM068-075, HRM044-056, HLH061-068, HLJ072-075	120Z0057
Belt type crankcase heater: 50W, 400V		120Z0058
Belt type crankcase heater: 65W, 230V		120Z0059
Belt type crankcase heater: 65W, 400V		120Z0060
Belt type crankcase heater: 70W, 230V	HLM078-081, HCM094-120, HLJ083, HCJ090-120	120Z5040
Belt type crankcase heater: 70W, 400/440V		120Z5041

S Series - Light Commercial and Commercial Scroll Compressors

Danfoss Performer® Universal Scroll Compressors are designed to serve as quick, easy replacements for most commercial air conditioning scroll compressors. These compressors come with a bolt pattern, suction and discharge lines, and performance characteristics that match up directly with some competitors' products.



Nomenclature / Model No.

SM 115 S 4 Q C
DSH 090 A 4 AL C

Refrigerant & oil

SM: R-22, mineral oil
SY: R-22, R-407C, R-134a, POE oil
SZ: R-407C, R-134a, R-404A / R-507A, POE oil
DSH: R-410A, POE oil

Nominal Capacity

In thousand Btu/h at 60 Hz, ARI Conditions

UL index

Motor voltage code

3: 200-230 V / 3 ph / 60 Hz
4: 380-400 V / 3 ph / 50 Hz & 460 V / 3 ph / 60 Hz
6: 230 V / 3 ph / 50 Hz
7: 500 V / 3 ph / 50 Hz & 575 V / 3 ph / 60 Hz
9: 380 V / 3 ph / 60 Hz

Evolution index

Version (for SM, SY, SZ)	Motor protection module	Connection	Module voltage	Applies to
V	Internal overload protector	brazed		084, 090, 100, 110, 120, 148, 161
A		brazed		112, 124, 147
C	Internal thermostat	brazed		115, 125, 160, 175, 185
Q		brazed		
R		rotolock		
P	Electronic protection module	brazed	24V AC	240, 300, 380
X		brazed	230V	
S		rotolock	24V AC	
Y		rotolock	230V	
CA		brazed	24V AC	
CB		brazed	115/230V	
PA		rotolock	24V AC	
PB	rotolock	115/230V		
AC	contact OEM			

Version (for SH)	Motor protection module	Connection	Module voltage	Applies to
AL	Internal overload protector	brazed		090, 105, 120, 140, 161, 175, 184
AA	Electronic protection module	brazed	24V AC	240, 295, 300, 380, 485
AB		brazed	115/230V	
AB		brazed	230V	
AC	contact OEM			

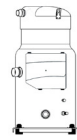

Technical data and ordering

S Series - Scroll Compressors

Nominal tonnage	Voltage/Phase/Frequency	Competitor Part Nos. ¹		Net weight (lbs.)	Connection size/type (suction x discharge)	Solder sleeve adapter set for Rotolock connectors	R-22		R-407C	
							Danfoss Model No.	Danfoss Code No. ²	Danfoss Model No.	Danfoss Code No. ²
7 ½	200-230/3/60		ZR94KC-TF5	143	1 ¾ x ¾ Brazed	7765005	SM090S3VC	SM090-3VI	SZ090S3VC	SZ090-3VI
	460/3/60 400/3/50		ZR94KC-TFD				SM090S4VC	SM090-4VI	SZ090S4VC	SZ090-4VI
9 ½	200-230/3/60	CSHA-093R-0*00 or 0A	ZR108KC-TF5 ZR11M3-TWC	172	1 ¾ x ¾ Brazed	120Z0405	SM115S3QC	SM115-3QAI	SZ115S3QC	SZ115-3QAI
	460/3/60 400/3/50	CSHA-093K-0*00 or 0A	ZR108KC-TFD ZR11M3-TWD				SM115S4QC	SM115-4QAI	SZ115S4QC	SZ115-4QAI
10	200-230/3/60	CSHA-100R-0*00 or 0A	ZR125KC-TF5 ZR12M3-TWC	198	1 ¾ x 1 ¾ Brazed	7765028	SM125S3QC	SM125-3QAI	SZ125S3QC	SZ125-3QAI
	460/3/60 400/3/50	CSHA-100K-0*00 or 0A	ZR125KC-TFD ZR12M3-TWD				SM125S4QC	SM125-4QAI	SZ125S4QC	SZ125-4QAI
12 ½	200-230/3/60	CSHA-125R-0*00 or 0A	ZR16M3-TWC	220	1 ¾ x 1 ¾ Brazed	7765028	SM160T3CC	SM160-3CBI	SZ160T3CC	SZ160-3CBI
	460/3/60 400/3/50	CSHA-125K-0*00 or 0A	ZR16M3-TWD				SM160T4CC	SM160-4CBI	SZ160T4CC	SZ160-4CBI
14	200-230/3/60	CSHA-140R-0*00 or 0A		220	1 ¾ x 1 ¾ Brazed	7765028	SM175S3QC	SM175-3QAI	SZ175S3QC	SZ175-3QAI
	460/3/60 400/3/50	CSHA-140K-0*00 or 0A					SM175S4QC	SM175-4QAI	SZ175S4QC	SZ175-4QAI
15	200-230/3/60	CSHA-150R-0*00 or 0A	ZR190KC-TW5 ZR19M3-TWC	220	1 ¾ x 1 ¾ Brazed	7765028	SM185S3QC	SM185-3QAI	SZ185S3QC	SZ185-3QAI
	460/3/60 400/3/50	CSHA-150K-0*00 or 0A	ZR190KC-TWD ZR19M3-TWD				SM185S4QC	SM185-4QAI	SZ185S4QC	SZ185-4QAI

¹ Competitor Model Nos. beginning "ZR" may have different footprint, suction, discharge or height compared to Danfoss Model No.

² Code Nos. ending "QAI" include threaded sight glass, ¾ in. flare SAE oil equalization connection, brazed suction and discharge connections and mounting bracket.

Code Nos. ending "VI" and "CBI" have threaded sight glass, ¾ in. flare SAE oil equalization connection and brazed suction and discharge connections. Use compressor beginning with SM when system will use R-22; use compressor beginning with SZ when retrofitting system to R-407C. For additional information, see Danfoss Literature No. DKRCC.PE.000.H1.02 (<http://bit.ly/RefrigerantRetrofits>)

Full range of models (refrigerants, tons, and voltage codes) available. Check Coolselector or visit our Online Datasheet Generator at www.danfoss.com/odsg.

Spare Parts and Accessories

Description	Type(s) applied to	Danfoss Code No.
Solder sleeve adapter set (1 ¾ in. rotolock, 1 ½ in. ODF), (1 ¼ in. rotolock, ¾ in. ODF)	SH090	120Z0125
Solder sleeve adapter set (1 ¾ in. rotolock, 1 ¾ in. ODF), (1 ¼ in. rotolock, ¾ in. ODF) *diameter restrictor	SM115, 125, 160, DSH105, 120, 140, 161, 184	7765006
Solder sleeve adapter set (1 ¾ in. rotolock, 1 ¾ in. ODF), (1 ¼ in. rotolock, ¾ in. ODF)	SM115, 125, SZ115, 125, DSH105, 120, 140, 161, 184	120Z0405
Solder sleeve adapter set (2 ¾ in. rotolock, 1 ¾ in. ODF), (1 ¾ in. rotolock, ¾ in. ODF)	SM160, 175, 185, SZ160, 175, 185, DSH240, 295, 380, 381	7765028
Motor protection module, 24V AC	SM115, 125, 160, 185	120Z0584
Electrical module 115/230V	DSH 240, 295, 380	120Z0585
Belt type crankcase heater; 65W, 460V	SM115, 125, 160, DSH090, 105, 120, 140, 161, 175, 184	120Z0466
Belt type crankcase heater; 65W, 110V		7773109
Belt type crankcase heater; 65W, 230V		7773107
Belt type crankcase heater; 65W, 400V		7773117
Belt type crankcase heater; 65W, 400V		120Z0039
Belt type crankcase heater; 75W, 110V		7773110
Belt type crankcase heater; 75W, 230V		7773108
Belt type crankcase heater; 75W, 400V	SM175, 185, DSH240, 295	7773118
Belt type crankcase heater; 75W, 460V		120Z0464
Belt type crankcase heater, 130W, 110V	DSH380	7773121
Belt type crankcase heater, 130W, 230V		7773122
Belt type crankcase heater, 130W, 400V		7773123
Service kit for terminal box; includes cover, clamp, terminal block connector	DSH090, 105, 120, 140, 161	8156135
Terminal box, including cover	SM115, 125, 160, 175, 185	8156139
Terminal box cover	DSH140-3, 161-3, 184, 175	120Z0413
Terminal box, including cover	DSH240, 295, 380	120Z0458
Oil sight glass with gaskets	SM090, 115, 125, 160, 175, 185	8156019
Mounting kit for 1 compressor: 4 grommets, 4 sleeves, 4 bolts, 4 washers	SM115-185	8156138
Mounting kit for 1 compressor: 4 grommets, 4 sleeves, 4 bolts, 4 washers	DSH090, 105, 120, 140, 161, 175, 184	120Z0066
Mounting kit for 1 compressor: 4 rigid grommets, 4 sleeves, 4 bolts, 4 washers	DSH240, 295, 380	7777045
Mineral oil, 160P; 2 liter can	all SM, SZ	7754001
Mineral oil, 160P; 5 liter can	all SM, SZ	7754002
Blue spray paint	all	8154001
Oil equalization adaptor. To connect ¾ in. tube on 22mm oil sight glass connection; includes (1) 22mm to ¾ in., (2) gaskets.	all SM, SZ, DSH	120Z0164
Oil equalization adaptor. To connect ½ in. tube on 22mm oil sight glass connection; includes (1) 22mm to ½ in., (2) gaskets.	all SM, SZ, DSH	120Z0165
Oil equalization adaptor kit for trio mounting; oil fittings, gasket and adaptors (copper pipes not included)	SM 160, 185	7773112

DSH Series - Light Commercial and Commercial Scroll Compressors with Intermediate Discharge Valves

Refrigerant	Nominal tonnage	Voltage/phase/frequency	Competitor model no. ¹		Motor protection	Net weight (lbs.)	Solder ODF connection (in.)	Solder sleeve adaptor set to Rotolock connections	OLD Danfoss Model No.	OLD Danfoss Code No. ²	NEW Danfoss Model No. ³	NEW Danfoss Code No. ²		
R-410A	7 ½	200–230/3/60	CCSHD-089J	ZP90KCE-TF5	Internal Overload Protector	128	1 ½ × ¾	120Z0125	SH090A3AL*	120H0001	DSH090A3AL*	120H1866		
		460/3/60	CSHD-089K	ZP90KCE-TFD					SH090A4AL*	120H0003	DSH090A4AL*	120H1511		
	8 ¾	200–230/3/60	CSHD-105J	ZP103KCE-TF5		141	141	1 ¾ × ¾	120Z0405	SH105A3AL*	120H0209	DSH105A3AL*	120H1860	
		460/3/60	CSHD-105K	ZP103KCE-TFD						SH105A4AL*	120H0211	DSH105A4AL*	120H1521	
	10	200–230/3/60	CSHD-125J	ZP120KCE-TF5		152	152	1 ¾ × ¾	120Z0405	SH120A3AL*	120H0011	DSH120A3AL*	120H1854	
		460/3/60	CSHD-125K	ZP120KCE-TFD						SH120A4AL*	120H0013	DSH120A4AL*	120H1531	
	11 ½	200–230/3/60	CSHD-142J	ZP137KCE-TF5		148	148	1 ¾ × ¾	120Z0405	SH140A3AL*	120H0199	DSH140A3AL*	120H1806	
		460/3/60	CSHD-142K	ZP137KCE-TFD						SH140A4AL*	120H0201	DSH140A4AL*	120H1541	
	13 ½	200–230/3/60	CSHD-161J	ZP154KCE-TF5		152	152	1 ¾ × ¾	120Z0405	SH161A3AL*	120H0021	DSH161A3AL*	120H1808	
		460/3/60	CSHD-161K	ZP154KCE-TFD						SH161A4AL*	120H0023	DSH161A4AL*	120H1551	
	15	200–230/3/60	CSHD-183J	ZP182KCE-TF5		158	158	1 ¾ × ¾	120Z0405	SH184A3AL*	120H0359	DSH184A3AL*	120H1810	
		460/3/60	CSHD-183K	ZP182KCE-TFD						SH184A4AL*	120H0361	DSH184A4AL*	120H1816	
	20	200–230/3/60	CSHN-176J	ZP236KCE-TW5 ²		24V AC 115/230V	251	251	1 ¾ × ¾	120Z0405	SH240A3AA*/ DSH240A3AAA SH240A3AB*/ DSH240A3ABA	120H0289/ 120H1159 120H0297/ 120H1161	DSH240A3AA* DSH240A3AB*	120H1749 120H1751
		460/3/60	CSHN-176K	ZP236KCE-TWD ²		24V AC 115/230V					SH240A4AA*/ DSH240A4AAA SH240A4AB*/ DSH240A4ABA	120H0291/ 120H1119 120H0299/ 120H1121	DSH240A4AA* DSH240A4AB*	120H1376 120H1374
	25	200–230/3/60	CSHN-250J	ZP295KCE-TW5 ²		24V AC 115/230V	258	258	1 ¾ × 1 ½	7765028	SH295A3AA*/ DSH295A3AAA SH295A3AB*/ DSH295A3ABA	120H0851/ 120H1163 120H0853/ 120H1165	DSH295A3AA* DSH295A3AB*	120H1745 120H1747
		460/3/60	CSHN-250K	ZP295KCE-TWD ²		24V AC 115/230V					SH295A4AA*/ DSH295A4AAA SH295A4AB*/ DSH295A4ABA	120H0825/ 120H1123 120H0827/ 120H1125	DSH295A4AA* DSH295A4AB*	120H1372 120H1370
	30	200–230/3/60	CSHN-315J	ZP385KCE-TW5 ²		24V AC 115/230V	357	357	1 ¾ × 1 ½	120Z0504	SH380A3AA*/ DSH381A3AAA SH380A3AB*/ DSH381A3ABA	120H0151/ 120H1167 120H0152/ 120H1169	DSH381A3AA* DSH381A3AB*	120H1741 120H1743
		460/3/60	CSHN-315K	ZP385KCE-TWD ²		24V AC 115/230V					SH380A4AA*/ DSH381A4AAA SH380A4AB*/ DSH381A4ABA	120H0253/ 120H1127 120H0255/ 120H1129	DSH381A4AA* DSH381A4AB*	120H1368 120H1366
	40	200–230/3/60				24V AC 115/230V	388	388	1 ¾ × 1 ½	120Z0504	DSH485A3AAA	120H1105	DSH485A3AA* DSH485A3AB*	120H1737 120H1739
		460/3/60				24V AC 115/230V					DSH485A4AAA DSH485A4ABA	120H1131 120H1133	DSH485A4AA* DSH485A4AB*	120H1364 120H136
	50	460/3/60				24V AC 115/230V	474	474	2 ½ × 1 ¾	N/A			DSH600A4AA* DSH600A4AB*	120H1788 120H1786

¹ Competitor Model Nos. beginning "ZP" may have different footprint, suction, discharge or height compared to Danfoss Model No.

² Control voltage of external motor protection module must be checked before crossing to Danfoss Model No with 24V ac or 115/230V motor protection module.

³ Intermediate Discharge Valves (IDVs) are mechanical valves that improve the partload efficiency of air conditioning systems. The Danfoss scroll range with IDVs is backwards compatible with existing Danfoss scrolls to reduce complexity and save time during installation.

Full range of models (refrigerant, tons, and voltage codes) available. Check Coolselector or visit our Online Datasheet Generator at www.danfoss.com/odsg.

Visit <http://bit.ly/DSHappguide> for the application guideline.

REFRIGERATION & AIR CONDITIONING

Automatic Controls | Condensing Units | Compressors

90 years

The industry's widest
expertise at your
disposal. We've been
looking ahead since
1933.

