

ENGINEERING
TOMORROW

Danfoss

Brochure | iC2-Micro & VLT® Micro Drive FC 51

Comparison of features and specifications for iC2-Micro and VLT® Micro Drive FC 51



Run reliably at full
load for ambient
temperatures up to

50 °C

 drives.danfoss.com



Contents

| | |
|--|---|
| General comparison of iC2-Micro and VLT® Micro Drive FC 51 | 3 |
| Model code and type code comparison | 4 |
| Product models comparison | 5 |
| Comparison of dimensions and mounting clearance | 6 |
| Comparison of terminals..... | 8 |

For your convenience in selecting and retrofitting drives, we provide some key comparative features and specifications of the iC2-Micro and VLT® Micro Drive FC 51.



iC2-Micro



VLT® Micro Drive FC 51

General **comparison** of iC2-Micro and VLT® Micro Drive FC 51

Key specifications

| Attribute | iC2-Micro | VLT® Micro Drive FC 51 |
|---|---|--|
| 3-phase 380-480 V | 0.37 – 22 kW | 0.37 – 22 kW |
| 1-phase 200-240 V | 0.37 – 2.2 kW | 0.18 – 2.2 kW |
| 3-phase 200-240 V | 0.37 – 11 kW | 0.25 – 3.7 kW |
| 1-phase 100-120 V | 0.37 – 1.1 kW | N.A. |
| Enclosure | IP20/Open type | IP20/Open type |
| Motor type | IM, PM (SPM & IPM) | Only IM |
| Motor identification | Automatic Motor Adaptation (AMA) | Automatic Motor Tuning (AMT) |
| Output frequency | Induction motor <ul style="list-style-type: none"> • 0-200 Hz (VVC+ mode) • 0-500 Hz (U/f mode) PM motor <ul style="list-style-type: none"> • 0-400 Hz (VVC+ mode) | Induction motor <ul style="list-style-type: none"> • 0-200 Hz (VVC+ mode) • 0-400 Hz (U/f mode) |
| Ramp time | 0.01-3600 sec | 0.05-3600 sec |
| Overload capacity | 150% for 1 minute | 150% for 1 minute |
| Overload torque at start | 200%/1s | N.A. |
| Maximum motor cable length (unshielded) | 75 m (246 ft) | 50 m (164 ft) |
| EMC filter | Two versions: <ul style="list-style-type: none"> • Built-in EMC filter • Without built-in EMC filter | Built-in EMC filter |
| Cooling fan | Replaceable fan with fan on/off control | Fixed fan without fan control |
| Ambient temperature | 50°C (122°F) at full load Max. 55°C (131°F) with derating | 40°C (104°F) at full load Max. 50°C (122°F) with derating |
| Natural cooling | Frame size MA01c | N.A. |
| HMI | Built-in control panel with potentiometer as default. Control Panel 2.0 OP2 as external control panel option: <ul style="list-style-type: none"> • Multi-language texts display • Easy for commissioning • Parameters setting and copy • Support two kinds of cabinet mounting kit <input checked="" type="checkbox"/> For control panel details, refer to the Application Guide | Detachable numerical control panel as option: <ul style="list-style-type: none"> • VLT® Control Panel LCP 11 without potentiometer • VLT® Control Panel LCP12 with potentiometer <input checked="" type="checkbox"/> For control panel details, refer to the Programming Guide |
| PC tool | MyDrive® Insight | VLT® Motion Control Tool MCT 10 |
| Off-line configuration | With adapter option, support off-line configuration | N.A. |
| Torque control | Torque open loop control | N.A. |
| Process controller | PID controller | PI controller |
| Logical control | Smart Logic Controller (SLC) | Smart Logic Controller (SLC) |
| RS485 port baud rate | Max. 115,000 baud communication speed | Max. 38,400 baud communication speed |
| Extra RJ45 port | RS485 based, and used for connecting external control panel and PC tool. | N.A. |
| Safety standards | EN/IEC 61800-5-1, UL 61800-5-1 | EN/IEC 61800-5-1, UL 508C |
| UL LZGH2/8 certification | Certified in accordance with UL/IEC 60335-2-40 and CSA C22.2 No.0335-2-40 | N.A. |
| New features | <ul style="list-style-type: none"> • Kinetic backup • Clockwise direction • Latch start reverse • Input phase loss trip • Setting wizard with application selections • Dead zone control • Sleep mode function | N.A. |



Model code and type code comparison

iC2-Micro model code definition

| 1 | 2 | 3 | 4 | 5 | 6 | 7 | 8 | 9 | 10 | 11 | 12 | 13 | 14 | 15 | 16 | 17 | 18 | 19 | 20 | 21 | 22 | 23 | 24 | 25 | 26 | 27 | |
|---|---|---|---|---|---|---|---|---|----|----|----|----|----|----|----|----|----|----|----|----|----|----|----|----|----|----|---|
| i | C | 2 | - | 3 | 0 | F | A | 3 | N | 0 | 4 | - | 0 | 1 | A | 2 | E | 2 | 0 | F | 4 | + | A | C | X | X | |
| | | | | | | | | 1 | N | 0 | 2 | | | | | | | | | | F | 2 | | A | C | B | C |
| | | | | | | | | | | 0 | 1 | | | | | | | | | | F | 0 | | | | | |

Product group
iC2-30

Product category
FA Frequency converter air cooled

Product type
3N Three phases
1N Single phase

Mains voltage
04 380-480 V AC
02 200-240 V AC
01 100-120 V AC

***Current rating**
*See current rating on page 3

Protection rating
E20 IP20/Open Type

EMC category
F4 C4 category
F2 C2 category
F0 C1 category

Brake chopper
+ACXX None
+ACBC Integrated

VLT® Micro Drive FC 51 type code definition

| 1 | 2 | 3 | 4 | 5 | 6 | 7 | 8 | 9 | 10 | 11 | 12 | 13 | 14 | 15 | 16 | 17 | 18 | 19 | 20 | 21 | 22 | 23 | 24 | 25 | 26 | 27 | |
|---|---|---|---|---|---|---|---|---|----|----|----|----|----|----|----|----|----|----|----|----|----|----|----|----|----|----|--|
| F | C | - | 0 | 5 | 1 | P | K | 3 | 7 | T | 4 | E | 2 | 0 | H | 3 | X | X | C | X | X | X | S | X | X | X | |
| | | | | | | | | | | T | 2 | | | | H | X | B | | | | | | | | | | |
| | | | | | | | | | | S | 2 | | | | | | | | | | | | | | | | |

Product series
VLT® Micro Drive FC51

***Power size**
*See power rating on page 5

Mains voltage
S2 Single phase 200-240 V AC
T2 Three phases 200-240 V AC
T4 Three phases 380-480 V AC

Protection rating
E20 IP20/Chassis

RFI filter
H3 RFI Class A1/B
HX No RFI filter

Hardware, coating
C Coated PCB

Hardware display
X No display
B Brake chopper

Hardware, mains option
X No mains option

Hardware, adaption A
X No adaption

Hardware, adaption B
X No adaption

SXXX Standard SW

Brake chopper
X No brake chopper
B Brake chopper

Product models comparison

Voltage 1 x 100-120 V AC

| Power rating [kW/ hp] | Current rating [A] | iC2-Micro | | | | VLT® Micro Drive FC 51 | | | |
|-----------------------|--------------------|-----------------------------|-----------|-----------|---------------|------------------------|-----------|-----------|---------------|
| | | Model code | Enclosure | EMC level | Brake chopper | Type code | Enclosure | EMC level | Brake chopper |
| 0.37/ 0.5 | 2.4 | iC2-30FA1N01-02A4E20F4+ACXX | MA01c | C4 | No | N.A. | | | |
| 1.1/ 1.5 | 4.8 | iC2-30FA1N01-04A8E20F4+ACXX | MA02c | C4 | No | N.A. | | | |

Voltage 1 x 200-240 V AC

| Power rating [kW/ hp] | Current rating [A] | iC2-Micro | | | | VLT® Micro Drive FC 51 | | | |
|-----------------------|--------------------|--|-----------|-----------|---------------|----------------------------|-----------|-----------|---------------|
| | | Model code | Enclosure | EMC level | Brake chopper | Type code | Enclosure | EMC level | Brake chopper |
| 0.18/ 0.24 | 1.2 | N.A. | | | | FC-51PK18S2E20H3XXCXXXSXXX | M1 | C1 | No |
| 0.37/ 0.5 | 2.2 | iC2-30FA1N02-02A2E20F0+ACXX iC2-30FA1N02-02A2E20F4+ACXX | MA01c | C1 & C4 | No | FC-51PK37S2E20H3XXCXXXSXXX | M1 | C1 | No |
| 0.75/ 1.0 | 4.2 | iC2-30FA1N02-04A2E20F0+ACXX iC2-30FA1N02-04A2E20F4+ACXX | MA01c | C1 & C4 | No | FC-51PK75S2E20H3XXCXXXSXXX | M1 | C1 | No |
| 1.5/ 2.0 | 6.8 | iC2-30FA1N02-06A8E20F0+ACXX iC2-30FA1N02-06A8E20F4+ACXX | MA02c | C1 & C4 | No | FC-51P1K5S2E20H3BXCXXXSXXX | M2 | C1 | No |
| 2.2/ 3.0 | 9.6 | iC2-30FA1N02-09A6E20F0+ACXX iC2-30FA1N02-09A6E20F4+ACXX | MA02a | C1 & C4 | No | FC-51P2K2S2E20H3BXCXXXSXXX | M3 | C1 | No |

Voltage 3 x 200-240 V AC

| Power rating [kW/ hp] | Current rating [A] | iC2-Micro | | | | VLT® Micro Drive FC 51 | | | |
|-----------------------------|-----------------------|-----------------------------|-----------|-----------|---------------|----------------------------|-----------|-----------|---------------|
| | | Model code | Enclosure | EMC level | Brake chopper | Type code | Enclosure | EMC level | Brake chopper |
| 0.18/ 0.24 | 1.2 | N.A. | | | | FC-51PK25T2E20H3XXCXXXSXXX | M1 | C2 | No |
| 0.37/ 0.5 | 2.4 | iC2-30FA3N02-02A4E20F4+ACXX | MA01a | C4 | No | FC-51PK37T2E20H3XXCXXXSXXX | M1 | C2 | No |
| 0.75/ 1.0 | 4.2 | iC2-30FA3N02-04A4E20F4+ACXX | MA01a | C4 | No | FC-51PK75T2E20H3XXCXXXSXXX | M1 | C2 | No |
| 1.5/ 2.0 | 7.8 | iC2-30FA3N02-07A8E20F4+ACBC | MA02a | C4 | Yes | FC-51P1K5T2E20H3BXCXXXSXXX | M2 | C2 | No |
| 2.2/ 3.0 | 11 | iC2-30FA3N02-11A8E20F4+ACBC | MA03a | C4 | Yes | FC-51P2K2T2E20H3BXCXXXSXXX | M3 | C2 | No |
| 3.7/ 5.0 | 15.2 | iC2-30FA3N02-15A8E20F4+ACBC | MA03a | C4 | Yes | FC-51P3K7T2E20H3BXCXXXSXXX | M3 | C2 | No |
| 5.5/ 7.5 | 24.2 | iC2-30FA3N02-24A2E20F4+ACBC | MA04a | C4 | Yes | N.A. | | | |
| 7.5/10 | 31.0 | iC2-30FA3N02-31A0E20F4+ACBC | MA04a | C4 | Yes | | | | |
| 11/15 | 46.2 | iC2-30FA3N02-46A2E20F4+ACBC | MA05a | C4 | Yes | | | | |

Voltage 3 x 380-480 V AC

| Power rating [kW/ hp] | Current rating [A] | iC2-Micro | | | | VLT® Micro Drive FC 51 | | | |
|-----------------------------|-----------------------|--|-----------|-----------|---------------|----------------------------|-----------|-----------|---------------|
| | | Model code | Enclosure | EMC level | Brake chopper | Type code | Enclosure | EMC level | Brake chopper |
| 0.37/ 0.5 | 1.2 | iC2-30FA3N04-01A2E20F2+ACXX iC2-30FA3N04-01A2E20F4+ACXX | MA01a | C2 & C4 | No | FC-51PK37T4E20H3XXCXXXSXXX | M1 | C2 | No |
| 0.75/ 1.0 | 2.2 | iC2-30FA3N04-02A2E20F2+ACXX iC2-30FA3N04-02A2E20F4+ACXX | MA01a | C2 & C4 | No | FC-51PK75T4E20H3XXCXXXSXXX | M1 | C2 | No |
| 1.5/ 2.0 | 3.7 | iC2-30FA3N04-03A7E20F2+ACXX iC2-30FA3N04-03A7E20F4+ACXX | MA01a | C2 & C4 | No | FC-51P1K5T4E20H3BXCXXXSXXX | M2 | C2 | Yes |
| 2.2/ 3.0 | 5.3 | iC2-30FA3N04-05A3E20F2+ACBC iC2-30FA3N04-05A3E20F4+ACBC | MA02a | C2 & C4 | Yes | FC-51P2K2T4E20H3BXCXXXSXXX | M2 | C2 | Yes |
| 3.0/4.0 | 7.2 | iC2-30FA3N04-07A2E20F2+ACBC iC2-30FA3N04-07A2E20F4+ACBC | MA02a | C2 & C4 | Yes | FC-51P3K0T4E20H3BXCXXXSXXX | M3 | C2 | Yes |
| 4.0/5.5 | 9.0 | iC2-30FA3N04-09A0E20F2+ACBC iC2-30FA3N04-09A0E20F4+ACBC | MA02a | C2 & C4 | Yes | FC-51P4K0T4E20H3BXCXXXSXXX | M3 | C2 | Yes |
| 5.5/ 7.5 | 12.0 | iC2-30FA3N04-12A0E20F2+ACBC iC2-30FA3N04-12A0E20F4+ACBC | MA03a | C2 & C4 | Yes | FC-51P5K5T4E20H3BXCXXXSXXX | M3 | C2 | Yes |
| 7.5/ 10 | 15.5 | iC2-30FA3N04-15A5E20F2+ACBC iC2-30FA3N04-15A5E20F4+ACBC | MA03a | C2 & C4 | Yes | FC-51P7K5T4E20H3BXCXXXSXXX | M3 | C2 | Yes |
| 11/15 | 23.0 | iC2-30FA3N04-23A0E20F2+ACBC iC2-30FA3N04-23A0E20F4+ACBC | MA04a | C2 & C4 | Yes | FC-51P11KT4E20H3BXCXXXSXXX | M4 | C2 | Yes |
| 15/20 | 31.0 | iC2-30FA3N04-31A0E20F2+ACBC iC2-30FA3N04-31A0E20F4+ACBC | MA04a | C2 & C4 | Yes | FC-51P15KT4E20H3BXCXXXSXXX | M4 | C2 | Yes |
| 18.5/ 25 | 37.0 | iC2-30FA3N04-37A0E20F2+ACBC iC2-30FA3N04-37A0E20F4+ACBC | MA05a | C2 & C4 | Yes | FC-51P18KT4E20H3BXCXXXSXXX | M5 | C2 | Yes |
| 22/30 | 43.0 | iC2-30FA3N04-43A0E20F2+ACBC iC2-30FA3N04-43A0E20F4+ACBC | | C2 & C4 | Yes | FC-51P22KT4E20H3BXCXXXSXXX | M5 | C2 | Yes |

Comparison of **dimensions** and **mounting clearance**

| Voltage type | Power rating [kW/hp] | iC2-Micro | | | | | | VLT® Micro Drive FC 51 | | | | | |
|--------------|-------------------------|-------------|-------------|--------------|-------------|------------|-------------|------------------------|-----------|--------------|-------------|------------|-------------|
| | | Height [H] | Width [W] | Depth [D] | Height [H1] | Width [W1] | Weight [kg] | Height [H] | Width [W] | Depth [D] | Height [H1] | Width [W1] | Weight [kg] |
| 1 x 100 V | | MA01c | | | | | | N.A. | | | | | |
| | 0.37/0.5 | 150 (5.9) | 70 (2.8) | 143 (5.6) | 140.4 (5.5) | 55 (2.2) | 1.0 | | | | | | |
| | | MA02c | | | | | | N.A. | | | | | |
| 1.1/1.5 | 176 (6.9) | 75 (3.0) | 157 (6.2) | 150.5 (5.9) | 59 (2.3) | 1.3 | | | | | | | |
| 1 x 220 V | 0.18/0.24 | N.A. | | | | | | M1 | | | | | |
| | | | | | | | | 150 (5.9) | 70 (2.8) | 148 (5.8) | 140.4 (5.5) | 55 (2.2) | 1.1 |
| | | MA01c | | | | | | M1 | | | | | |
| | 0.37/0.5 | 150 (5.9) | 70 (2.8) | 143 (5.6) | 140.4 (5.5) | 55 (2.2) | 1.0 | 150 (5.9) | 70 (2.8) | 148 (5.8) | 140.4 (5.5) | 55 (2.2) | 1.1 |
| | 0.75/1.0 | | | | | | | | | | | | |
| | 1.5/2.0 | 176 (6.9) | 75 (3.0) | 157 (6.2) | 150.5 (5.9) | 59 (2.3) | 1.3 | 176 (6.9) | 75 (3.0) | 168 (6.6) | 166.4 (6.6) | 59 (2.3) | 1.6 |
| | | MA02a | | | | | | M3 | | | | | |
| 2.2/3.0 | 186 (7.3) | 75 (3.0) | 175 (6.9) | 176.4 (6.9) | 59 (2.3) | 1.6 | 238.5 (9.4) | 90 (3.5) | 194 (7.6) | 226 (8.9) | 69 (2.7) | 3 | |
| 3 x 220 V | | MA01a | | | | | | M1 | | | | | |
| | 0.18/0.24 | N.A. | | | | | | | | | | | |
| | 0.37/0.5 | 150 (5.9) | 70 (2.8) | 158 (6.2) | 140.4 (5.5) | 55 (2.2) | 1.1 | 150 (5.9) | 70 (2.8) | 148 (5.8) | 140.4 (5.5) | 55 (2.2) | 1.1 |
| | 0.75/1.0 | | | | | | | | | | | | |
| | | MA02a | | | | | | M2 | | | | | |
| | 1.5/2.0 | 186 (7.3) | 75 (3.0) | 175 (6.9) | 176.4 (6.9) | 59 (2.3) | 1.6 | 176 (6.9) | 75 (3.0) | 168 (6.6) | 166.4 (6.6) | 59 (2.3) | 1.6 |
| | | MA03a | | | | | | M3 | | | | | |
| | 2.2/3.0 | 238.5 (9.4) | 90 (3.5) | 200 (7.9) | 226 (8.9) | 69 (2.7) | 3.0 | 238.5 (9.4) | 90 (3.5) | 194 (7.6) | 226 (8.9) | 69 (2.7) | 3.0 |
| | 3.7/5.0 | | | | | | | | | | | | |
| | | MA04a | | | | | | N.A. | | | | | |
| 5.5/7.5 | 292 (11.5) | 125 (4.9) | 244.5 (9.6) | 272.4 (10.7) | 97 (3.8) | 6.0 | | | | | | | |
| | MA05a | | | | | | | | | | | | |
| 11/15 | 335 (13.2) | 165 (6.5) | 248 (9.8) | 315 (12.4) | 140 (5.5) | 9.4 (20.7) | | | | | | | |
| 3 x 400 V | | MA01a | | | | | | M1 | | | | | |
| | 0.37/0.5 | 150 (5.9) | 70 (2.8) | 158 (6.2) | 140.4 (5.5) | 55 (2.2) | 1.1 | 150 (5.9) | 70 (2.8) | 148 (5.8) | 140.4 (5.5) | 55 (2.2) | 1.1 |
| | 0.75/1.0 | | | | | | | | | | | | |
| | | MA01a | | | | | | M2 | | | | | |
| | 1.5/2.0 | 150 (5.9) | 70 (2.8) | 158 (6.2) | 140.4 (5.5) | 55 (2.2) | 1.1 | 176 (6.9) | 75 (3.0) | 168 (6.6) | 166.4 (6.6) | 59 (2.3) | 1.6 |
| | | MA02a | | | | | | M2 | | | | | |
| | 2.2/3.0 | 186 (7.3) | 75 (3.0) | 175 (6.9) | 176.4 (6.9) | 59 (2.3) | 1.6 | 176 (6.9) | 75 (3.0) | 168 (6.6) | 166.4 (6.6) | 59 (2.3) | 1.6 |
| | | MA02a | | | | | | M3 | | | | | |
| | 3.0/4.0 | 186 (7.3) | 75 (3.0) | 175 (6.9) | 176.4 (6.9) | 59 (2.3) | 1.6 | 238.5 (9.4) | 90 (3.5) | 194 (7.6) | 226 (8.9) | 69 (2.7) | 3.0 |
| | 4.0/5.5 | | | | | | | | | | | | |
| | | MA03a | | | | | | M3 | | | | | |
| | 5.5/7.5 | 238.5 (9.4) | 90 (3.5) | 200 (7.9) | 226 (8.9) | 69 (2.7) | 3.0 | 238.5 (9.4) | 90 (3.5) | 194 (7.6) | 226 (8.9) | 69 (2.7) | 3.0 |
| | 7.5/10 | | | | | | | | | | | | |
| | | MA04a | | | | | | M4 | | | | | |
| 11/15 | 292 (11.5) | 125 (4.9) | 244.5 (9.6) | 272.4 (10.7) | 97 (3.8) | 6.0 | 292 (11.5) | 125 (5.0) | 241 (9.5) | 272.4 (10.7) | 97 (3.8) | 6.0 | |
| 15/20 | | | | | | | | | | | | | |
| | MA05a | | | | | | M5 | | | | | | |
| 18.5/25 | 335 (13.2) | 165 (6.5) | 248 (9.8) | 315 (12.4) | 140 (5.5) | 9.4 (20.7) | 335 (13.2) | 165 (6.5) | 248 (9.8) | 315 (12.4) | 140 (5.5) | 9.5 | |
| 22/30 | | | | | | | | | | | | | |

H = Height [mm (in)], W = Width [mm (in)], D = Depth [mm (in)], H1 = Height [mm (in)], W1 = Width [mm (in)]

Note

- H, W and D are for overall dimensions
- H1 and W1 are for mounting hole dimensions
- The potentiometer on the local control panel extends 6.5 mm (0.26 in) from the drive.

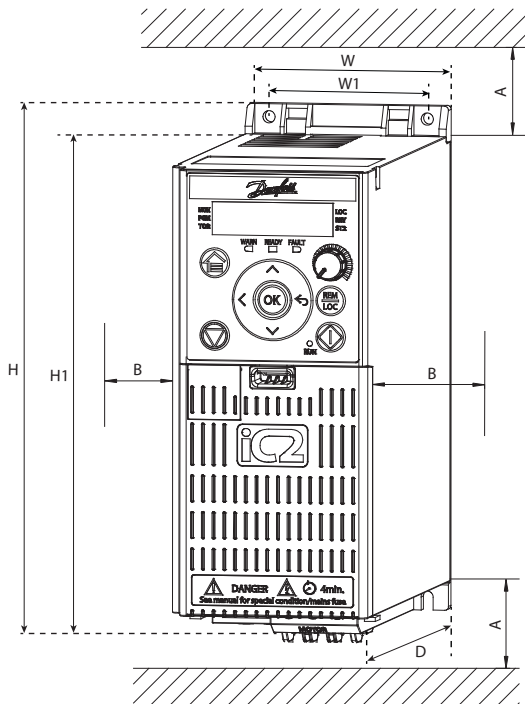

iC2-Micro

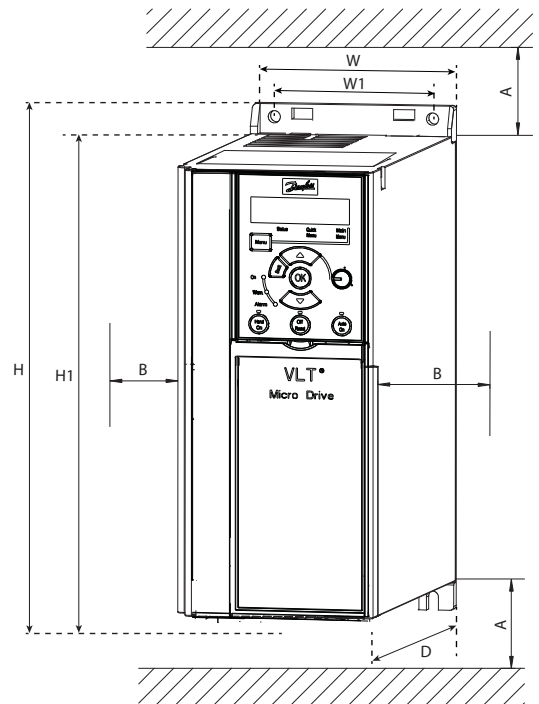

VLT® Micro Drive FC 51



Easy retrofit
 iC2-Micro is designed to be compatible with the VLT® Micro Drive FC 51, for a fast, streamlined retrofit

Mounting clearance

| | iC2-Micro | | VLT® Micro Drive FC 51 | |
|---------------------|-------------------------|--|------------------------|------------------------------------|
| Direction | Frame designation | Minimum cooling clearances | Enclosure size | Minimum cooling clearances |
| Above and below (A) | All frame designations | 100 mm (3.9 in) for 50 °C (122 °F) | All enclosure sizes | 100 mm (3.9 in) for 40 °C (104 °F) |
| | MA01a to MA05a, MA02c | 0 mm (0 in) for 50 °C (122 °F) | | |
| Sides (B) | MA01c (natural cooling) | 0 mm (0 in) for 40 °C (104 °F) | All enclosure sizes | 0 mm (0 in) for 40 °C (104 °F) |
| | | 10 mm (0.39 in) and above for 50 °C (122 °F) | | |



Comparison of terminals

Terminals

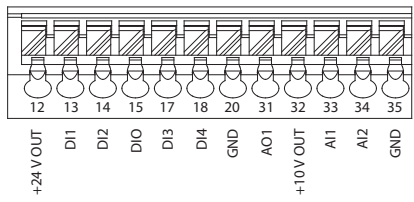
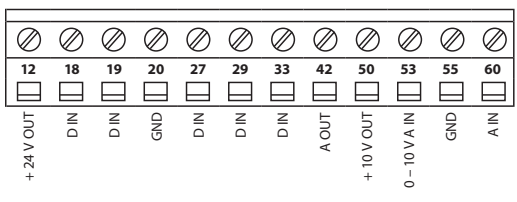
| Attribute | iC2-Micro | VLT® Micro Drive FC 51 |
|---------------------------|---|--|
| Terminal type | Spring type | Screw type |
| I/O terminals | Terminal number | Terminal number |
| | Type | Type |
| | T12 | 24V |
| | T13 | DI1 |
| | T14 | DI2 |
| | T15 | DIO |
| | T17 | DI3 |
| | T18 | DI4 |
| | T20 | GND |
| | T31 | AO1 |
| | T32 | 10V |
| | T33 | AI1 |
| | T34 | AI2 |
| T35 | GND | |
| | 01, 02, 03 | Relay |
| Digital output | Programmable T15 could be set as digital output. Max. output current is 40 mA | Programmable T42 could be set as digital output. Max. output current is 20 mA |
| Pulse input | Programmable T18 can be set as pulse input (4-32 kHz) | Programmable T33 can be set as pulse input (20-5000 Hz) |
| Pulse output | Programmable T15 can be set as pulse output (4-32 kHz) | N.A. |
| Analog inputs mode switch | By software paramter | By hardware switch |
| PNP & NPN switch | By software paramter | By hardware switch |
| Illustration |  |  |

How to order

To order, go to store.danfoss.com and choose country/region.



iC2-Micro is the convenient drive that gives you a new way to optimize efficiency and cost. With its compact design, it saves panel space to reduce system cost. Since it is compatible with diverse motor technologies such as induction, IPM and SPM, you can freely select the best-fit motor for your application. It's easy to commission, since it's equipped with startup wizards and application-oriented parameter groups. What are you waiting for? Here is the compact drive that's reliable and flexible, ready to power your pumps, fans, conveyors and mixers, textile machinery, palletizers, and packaging machines.

iC2

Follow us and learn more about AC drives

