

Selection Guide | VLT® FlexMotion™

Ultimate freedom – one system for **central** and **decentral** servo motion solutions

VLT® Multiaxis Servo Drive MSD 510 , VLT® Integrated Servo Drive ISD® 520 and VLT® Decentral Servo Drive DSD 520



Flexible
system for modular
machine architecture



The **future** of **smart machine design** – it's **flexible**

Are you striving to modularize machine architecture to suit your business?

Then take a look at Danfoss VLT® FlexMotion™. It's a multi-purpose universally compatible servo drive concept, designed to meet the requirements of tomorrow's machine architecture, today. Combine and **scale** the modules to suit your specific needs. That way, its central and decentral modules will allow you to achieve a multitude of functions. **Open** system architecture gives you total freedom to integrate with the motors and PLC you prefer.

Save time and costs thanks to numerous finesses facilitating **fast** installation and commissioning. All designed for absolutely **reliable** operation in demanding environments.

All in all, this system gives you the ultimate freedom in machine design.

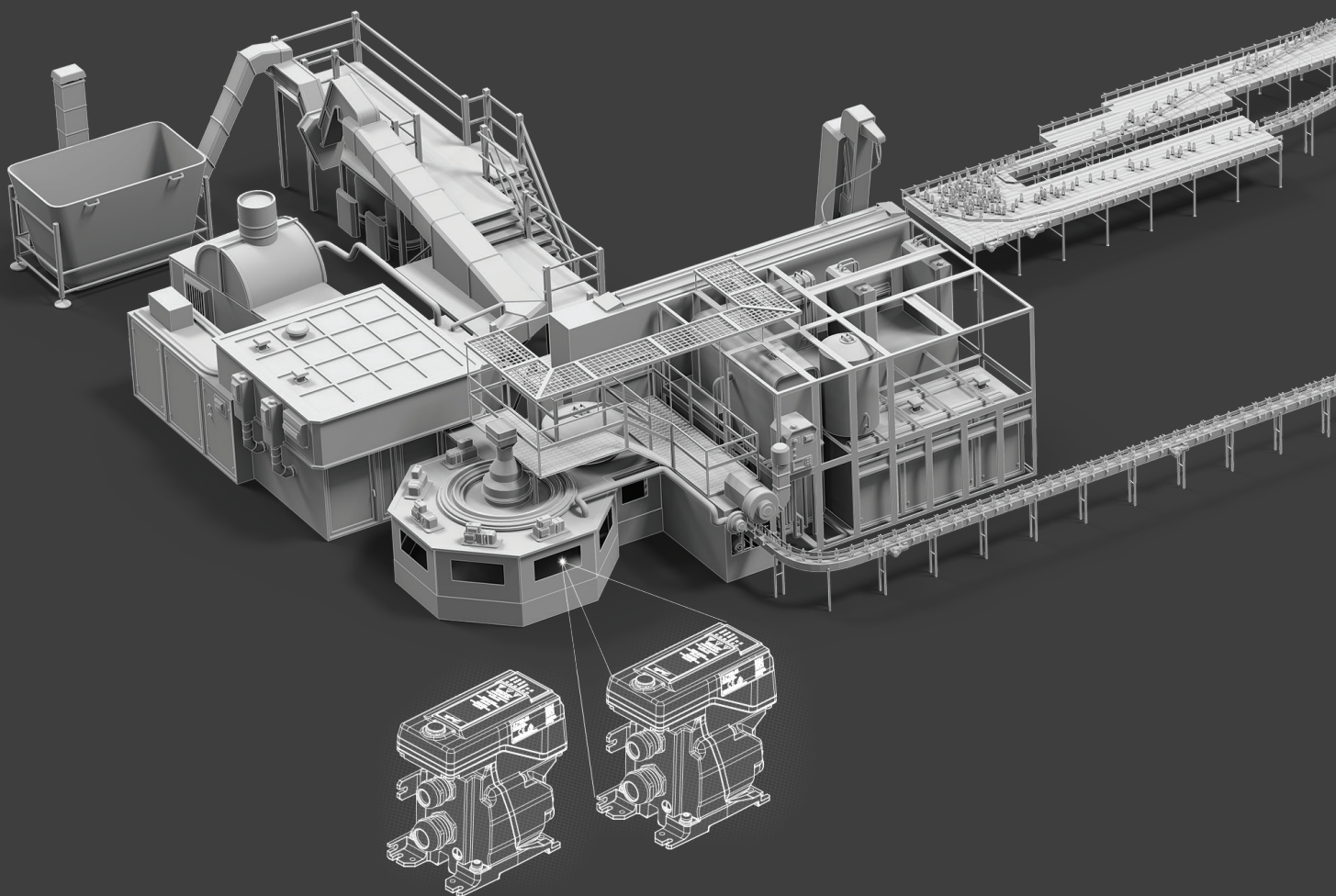

VLT® Decentral Servo Drive DSD 520

SCALABLE OPEN FAST RELIABLE

VLT® Integrated Servo Drive ISD® 520

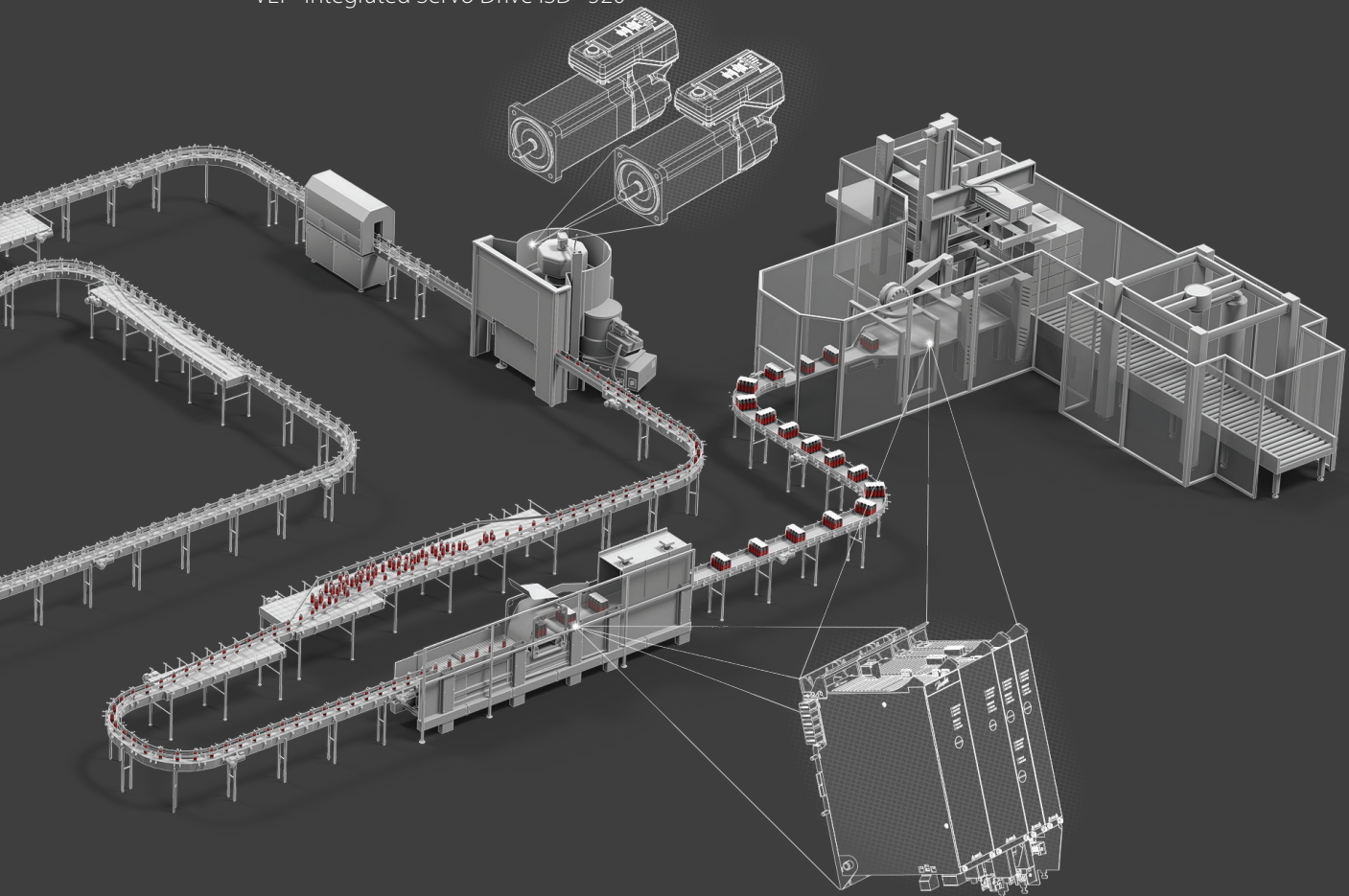

VLT® Multiaxis Servo Drive MSD 510

Let **flexibility flourish** in your machine design

Danfoss can help you wherever you are in your 'machines for smart manufacturing' journey. You can achieve a whole new degree of customization and precision – enabling you to get more from less. The combination of central and decentral drives in VLT® FlexMotion™ ensures you achieve maximum flexibility in machine design and system integration.

Be smart. Build your machine to meet tomorrow's requirements.

Let Danfoss support your business.

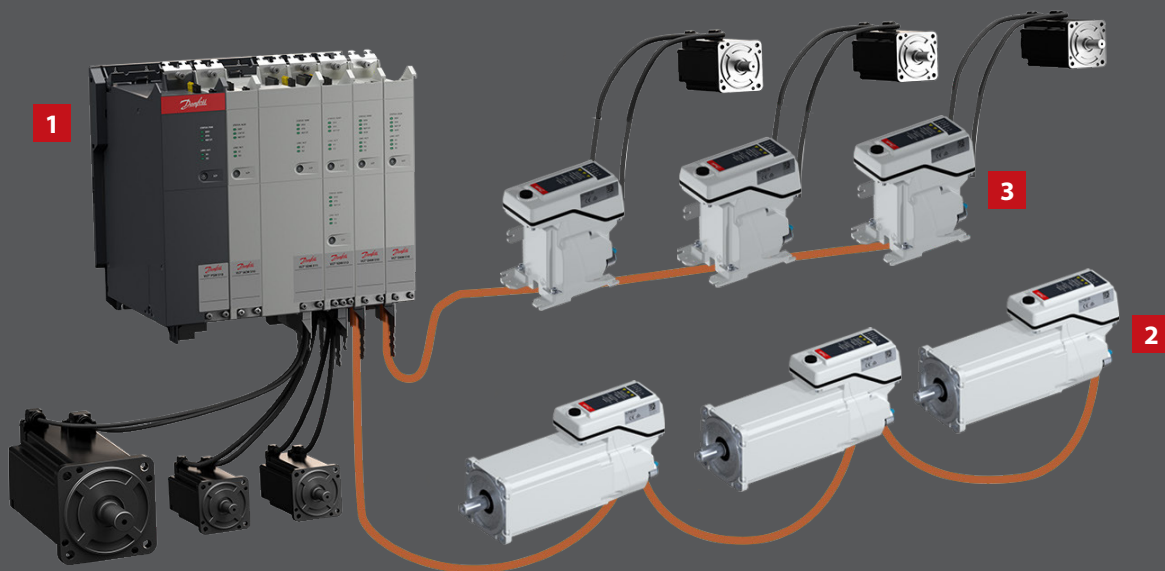

Build modular machines using a versatile system **Scalable concept**

Modern machine systems need to be extremely flexible in terms of adaptability and extensions. This criterion also applies for all the system components used in the VLT® FlexMotion™ machine design – it is specially designed to give you the ultimate freedom in your design projects.

Each module allows machine builders to sustain maximum flexibility in case the need arises to add a new line – or extend an existing line with additional drives.

Combine these VLT® FlexMotion™ product lines according to your needs:

- 1 VLT® Multiaxis Servo Drive MSD 510
- 2 VLT® Integrated Servo Drive ISD® 520
- 3 VLT® Decentral Servo Drive DSD 520

Use the VLT® Multiaxis Servo Drive MSD 510 as a servo hub and combine with standard permanent-magnet (PM) or asynchronous (ASM) motors, decentral servo drives (DSD 520) or even motors with integrated servo drives (ISD 520). This concept minimizes cabinet space occupied, cable length, and installation time. At the same time it maximizes performance, precision and modularity.

The VLT® Integrated Servo Drive ISD® 520 system serves a wide range of applications, such as turntable applications, labeling, capping, food packaging and pharmaceutical packaging.

You can tailor the drive to meet specific customer requirements thanks to:

- various drive optionals
- 5 flange sizes
- optional mechanical brake
- customization options

The VLT® Decentral Servo Drive DSD 520 improves your system flexibility by providing a wide range of feedback options and compatibility with PM as well as ASM motors.

All of these features support you in creating easily extendable and adaptable machines.

Specify the rest of the system as you please Free choice thanks to **open platform**

We respect that you are in the best position to decide what technologies are optimal for your system. Therefore, we leave all your options open and do not lock you into one protocol. We don't expect you to switch protocols to fit the drive – on the contrary, these drives fit into any system. Feel free to choose the communication and engineering platforms you prefer.

Your preferred protocol

The open system architecture of VLT® FlexMotion™ supports the real-time Ethernet protocols PROFINET®, POWERLINK® and EtherCAT®. It also allows you to use third-party master controllers. Program masters via IEC 61131-3 and PLCopen-conformant motion libraries make the system even more flexible and easy to integrate into diverse engineering environments. Gateway-free fieldbus communication contributes to seamless communication with less equipment. You can plug other fieldbus devices mounted in the machine directly into the advanced decentral drives.

Your safety net

Implement servo control for highly demanding applications with the factory option VLT® FlexSafety™, which offers numerous functional safety capabilities. Level SIL3 (IEC 61508), Ple / CAT3 (ISO 13849) is achievable for PROFIsafe and FSoE over fieldbus. The offering includes STO, SS1, SS2, SOS, SLA, SAR, SLS, SSR, SLP, SLI, SDI, SCA, SSM, SBC, SBT for safe stop, speed, ramp, CAM and brake functions. Optionally, safe digital inputs and outputs allow access to several functions independently from the fieldbus.

Your optimal motor

Whatever the need, you can choose the motor technology that best fits your application. Whether it's an ISD® 520 with nominal torque up to 13.8 Nm (peak torque up to 39 Nm), a combination of DSD 520 and a PM or ASM motor up to 2.3 kW power, or even a motor up to a power rating of 20 kW combined with one of the central servo drive modules (SDM 511 or SDM 512); by supporting a wider range of feedback encoders, your choice is completely open.



Save time in installation

Fast and fail-safe

Save time with effective measures that the system electrician will appreciate. With a fresh and inventive approach, the VLT® FlexMotion™ concept reduces the complexity of mounting and commissioning. And there are no compromises – the result meets the highest safety and quality standards.

Click and Lock mounting

Enjoy easy mounting and fail-safe installation thanks to the unique Click and Lock concept where DC-link and control voltage supply are integrated in the backplate of each module. Save time – there is no need to use additional components like wires or bus bars.

Intelligent user interface

Enjoy the effective all-in-one interface, VLT® Servo Toolbox software: It's streamlined, intuitive, and offers a wealth of integrated tools for commissioning, CAM editing, debugging and test runs.

Commission, troubleshoot and complete service tasks faster with the VLT® Local Control Panel LCP 102. It adds the power of speed in accessing the advanced decentral servo drives and all central modules of the concept. For fast working routines, it features a graphical display, quick access menus and a clear parameter structure as well as easy-to-read status LEDs.

Streamlined, fail-safe cabling

The decentralization of drives in the VLT® FlexMotion™ concept reduces the number of cables required. The VLT® Decentral Access Module DAM 510 connects to the first servo drive via a pre-configured hybrid

cable. This single cable combines the 565-680 V DC power supply, the 24/48 V DC, the STO signal and the bus communication. The hybrid cable loops these signals to further servo drives connected in the daisy-chain format.

For VLT® Integrated Servo Drive ISD® 520, this streamlined cabling infrastructure eliminates the need for extra equipment, such as separate feedback cables and connection boxes. The Plug and Twist cabling concept ensures fast and fail-safe installation.



When your name is at stake, integrity is critical **Reliable performance**

With your name on the machine it's essential to deliver quality. We recognize and respect your need to maintain the integrity you have established over long relationships with your customers. Save time on researching complex combinations of different equipment to achieve exactly the performance you require. With VLT® FlexMotion™ you tap into a coherent concept of building blocks with proven compatibility and performance. For any system you choose to build, the outcome is fuss-free reliability with maximum uptime.

Resistance in demanding environments

After years of working with the food and beverage industry, we understand the need for robust performance based on well-protected construction. Therefore, the decentral servo drives ISD® 520 and DSD 520 are available with enclosures rated up to IP67*. A completely smooth and easy-to-clean surface, free of cooling fins or fans, makes these drives hygienically fully reliable and chemical-resistant. Vibration class 3M7 ensures trouble-free operation and renders these drives ideal for rotating machine parts.

Time-saving straightforward design

Maintenance costs can be kept to a minimum because the VLT® FlexMotion™ modules are virtually maintenance-free – they're built for robust reliability. The drives use high-quality bearings, and the only spare part needed is the shaft seal. The fact that no tools are required to work with the hybrid cables results in significant time-savings.

Detect errors quickly via LED signals on all central and decentral modules.

The advanced drives versions provide three extra ports for:

- I/Os and external encoder; for example, homing or limit switches
- User interface: VLT® Local Control Panel LCP 102
- Fully functional Ethernet** (for direct connection of third-party fieldbus devices)

* for details please check ordering type codes on pages 15 and 17.

** available for EtherCAT and POWERLINK drives.

Typical applications

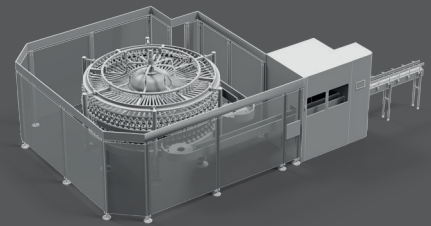

Beverage

- Labeling
- Capping
- PET blow-moulding
- Digital bottle printing

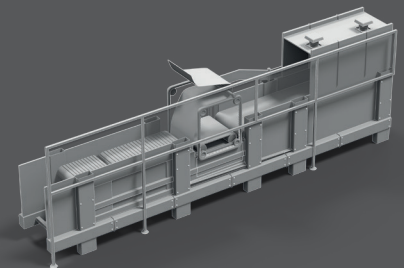

Food and beverage packaging

- Flow wrapping
- Bag maker
- Tray sealing
- Shrink wrapping

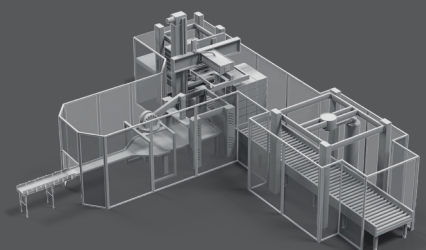

Industrial and pharmaceutical packaging

- Palletization
- Top loader
- Cartoning
- Tube filling
- Blister machine
- Liquid filling
- Solid dosing

VLT® Multiaxis Servo Drive MSD 510

The MSD 510 system is a generic central servo solution and forms the basis of the VLT® FlexMotion™ concept. Its flexibility and modularity in hardware and software gives you the freedom to design machines according to the application needs.

The MSD 510 system comprises these modules:

- VLT® Power Supply Module PSM 510
- VLT® Servo Drive Module SDM 511 for single axis and SDM 512 for double axis
- VLT® Decentral Access Modules DAM 510
- VLT® Auxiliary Capacitor Module ACM 510
- VLT® Expansion Module EXM 510

To optimize the space requirements, some of the modules are available in two frame sizes, either 50 mm [1.97 inch] or 100 mm [3.94 inch] wide.

Enjoy easy mounting and fail-safe installation thanks to a unique Click and Lock concept where DC-link and control voltage supply are integrated in the backplate of each module. Depending on the machine architecture, you can use the MSD 510 as a stand-alone central concept or in a mixed system together with the VLT® Integrated Servo Drive ISD® 520 and VLT® Decentral Servo Drive DSD 520. Extensions or adjustments to the machine are easy to implement – just add or swap modules accordingly.



> VLT® Power Supply Module PSM 510

> VLT® Servo Drive Modules SDM 511 and SDM 512

> VLT® Decentral Access Module DAM 510

> VLT® Auxiliary Capacitors Module ACM 510

> VLT® Expansion Module EXM 510

Specifications

Nominal input voltage	3 ~ 400-480 V AC +/-10%
Mains frequency	50/60 Hz
DC-link voltage	565-680 V DC +/-10%
Control voltage	24/48 V DC +/-10%
Ambient temperature	5-40 °C, max 55 °C with derating [41-104 °F, max 131 °F with derating]
Fieldbus	PROFINET®, POWERLINK®, EtherCAT®
IP protection class	IP20
Modular construction with 2 frame sizes	FS1 50 mm [1.97 inch] or FS2 100 mm [3.94 inch]
Mounting	Wall-mounting on backplate – click & lock
EMC according 61800-3	C3, C2 with external filter
Certificates/Approvals	CE, UL
Functional safety	STO SIL 2 Pl d

Dimensions

Frame size 1 (FS1)

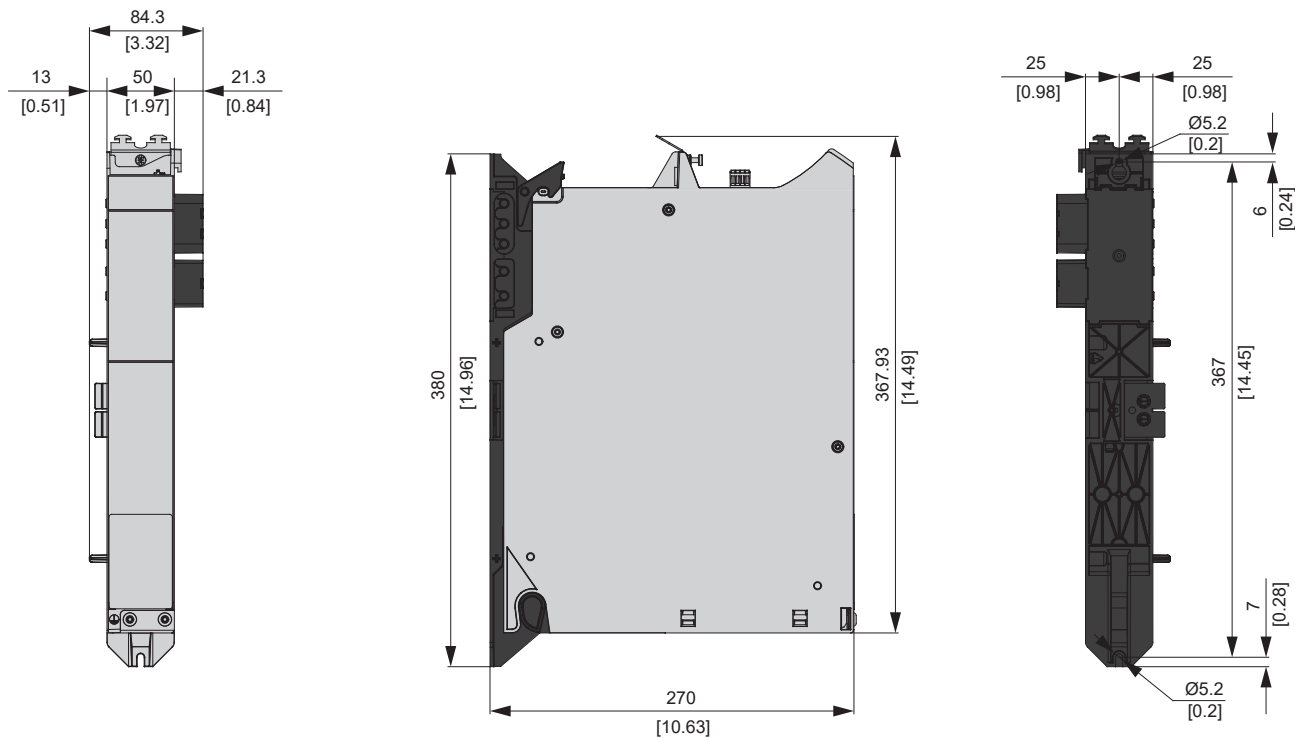

Frame size 2 (FS2)

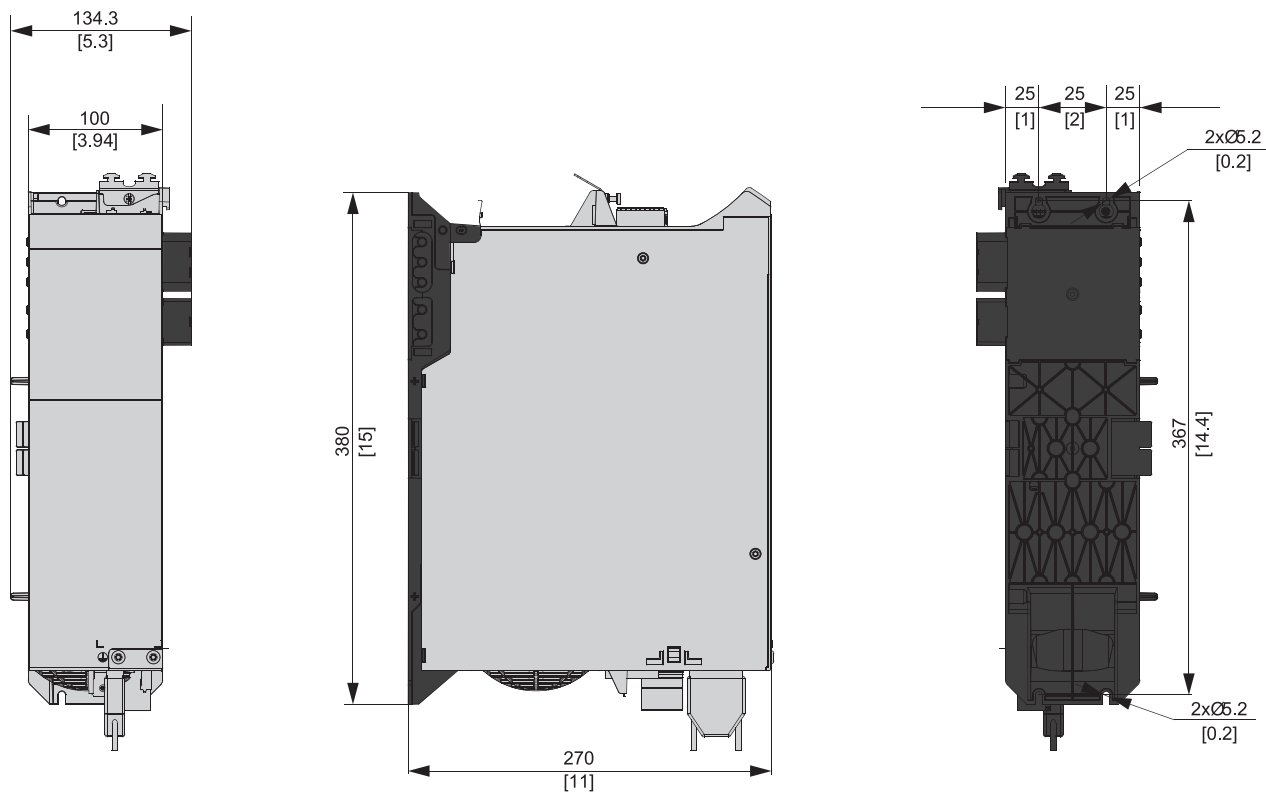

Dimensions are in mm [inch]

Expansion Module (EXM 510)

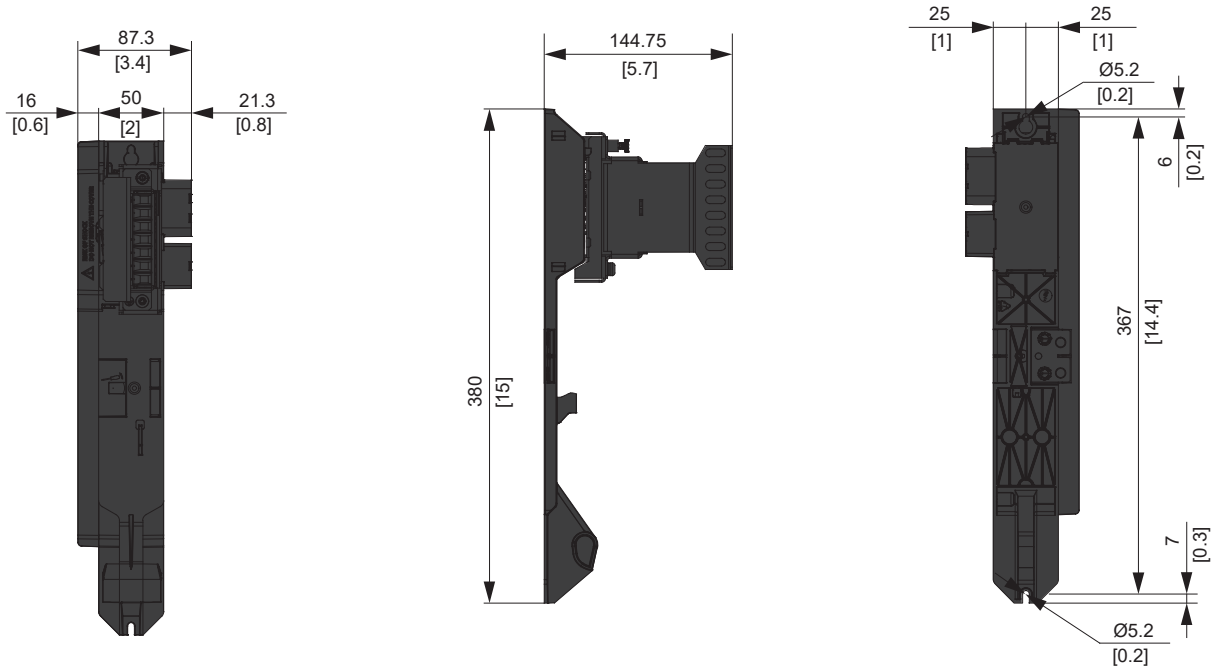

Dimensions are in mm [inch]

VLT® Power Supply Module PSM 510



The PSM 510 module generates a 565-680 DC-link voltage and is available in 3 power sizes with either 10, 20 or 30 kW and 200% overload capability. To achieve a nominal output up to 60 kW, install two PSM 510 units in parallel.

Specifications

		PSM 510 10 kW	PSM 510 20 kW	PSM 510 30 kW
Ordering number related to fieldbus variant	PROFINET®	175G0162	175G0165	175G0168
	POWERLINK®	175G0160	175G0163	175G0166
	EtherCAT®	175G0161	175G0164	175G0167
Nominal input voltage	V AC	3 x 400-480 +/-10%		
DC-link voltage	V DC	565-680 +/-10%		
Rated output current	A	20	40	60
Rated output power	kW [hp]	10 [13.4]	20 [26.8]	30 [40.2]
Peak current i_{max}	A	40	80	120
Peak power P_{max}	kW [hp]	20 [26.8]	40 [53.6]	60 [80.4]
Internal brake resistor				
Peak power P_{max}	kW		8	
Rated power P_N	W		150	
Nominal resistance	Ω		15	
External brake resistor				
Peak power P_{max}	kW		60	
Rated power P_N	kW		7.5	
Minimum resistance	Ω		10	
Cooling			Integrated fan	
Module width	mm [inch]		100 [3.94]	
Frame size			FS 2	
Weight	kg [lbs]		6 [13.2]	

VLT® Servo Drive Modules SDM 511 and SDM 512



The SDM 511 module is a single axis servo drive, available in 5 power sizes. The SDM 512 is a double axis servo drive, available in 3 power sizes.

A wide range of feedback options allows you to choose your preferred PM or ASM motor. Alternatively you can also run the motor without feedback. Furthermore, the drive modules are equipped with digital I/Os, relay outputs and integrated Safe Torque Off (STO).

Specifications

		SDM511-xx	SDM511-xx	SDM511-xx	SDM511-xx	SDM511-xx	SDM512-xx	SDM512-xx	SDM512-xx	
DC-link	V DC	565-680 +/-10%								
Rated current I _n	A	2.5	5	10	20	40	2 x 2.5	2 x 5	2 x 10	
Rated power P _n	kW [hp]	1.4 [1.9]	2.8 [3.8]	5.7 [7.6]	11.3 [15.2]	22.6 [30.3]	2 x 1.4 [1.9]	2 x 2.8 [3.8]	2 x 5.7 [7.6]	
Peak current	A	10	20	30	40	80	2 x 10	2 x 15	2 x 20	
Peak power	kW [hp]	5.7 [7.6]	11.3 [15.2]	17.0 [22.8]	22.6 [30.3]	45.2 [60.6]	2 x 5.7 [7.6]	2 x 8.4 [11.3]	2 x 11.3 [15.2]	
Nominal switching frequency	kHz	4/5								
Possible switching frequency	kHz	8/10								
Maximum output frequency	Hz	590								
Number of motor connections		1					2			
Cooling		Integrated fan								
Module width	mm [inch]	50 [1.97]			100 [3.94]		50 [1.97]			
Frame size		FS 1			FS 2		FS 1			
Weight	kg [lbs]	3.9 [8.6]			6.4 [14.1]		3.9 [8.6]			

Ordering type code

[1-6]	[7-12]	[13-14]	[15-16]	[17-21]	[22-23]	[24-26]	[27-29]	[30-31]	[32-34]	[35]	[36-38]	[39-40]				
MSD510	-	-	-	-	-	D6	-	E20	-	-	-	T	-	XXX	-	XX

Product group (character 1-6)	
MSD510	VLT® Multiaxis Servo Drive MSD
Product variant (character 7-12)	
SDM511	MSD 510 Servo Drive Module 511
SDM512	MSD 510 Servo Drive Module 512
Drive variant (character 13-14)	
SA	Single axis servo drive
DA	Double axis servo drive
Frame size (character 15-16)	
F1	Frame size 1 (50 mm)
F2	Frame size 2 (100 mm)
Current rating (character 17-21)	
C02A5	2.5 A _{RMS} rated current
C005A	5 A _{RMS} rated current
C010A	10 A _{RMS} rated current
C020A	20 A _{RMS} rated current
C040A	40 A _{RMS} rated current

DC voltage (character 22-23)	
D6	600 V DC-link voltage
Protection rating (character 24-26)	
E20	IP20
Drive feedback (character 27-29)	
FXX	Without feedback/Sensorless
FRX	Resolver
FS1	BiSS ST feedback 17-bit
FM1	BiSS MT feedback 17-bit
FE1	EnDat 2.1
FE2	EnDat 2.2
FHF	Hiperface
FHD	Hiperface DSL*
Bus system (character 30-31)	
PN	PROFINET®
PL	POWERLINK®
EC	EtherCAT®

Firmware (character 32-34)	
SXX	Standard
SC0	Customized
Functional safety (character 35)	
T	Safe Torque Off
Reserved (character 36-38)	
XXX	Reserved
Reserved (character 39-40)	
XX	Reserved

*In preparation

Please be aware that not all combinations are possible. Use the online configurator located here to configure your drive: driveconfig.danfoss.com

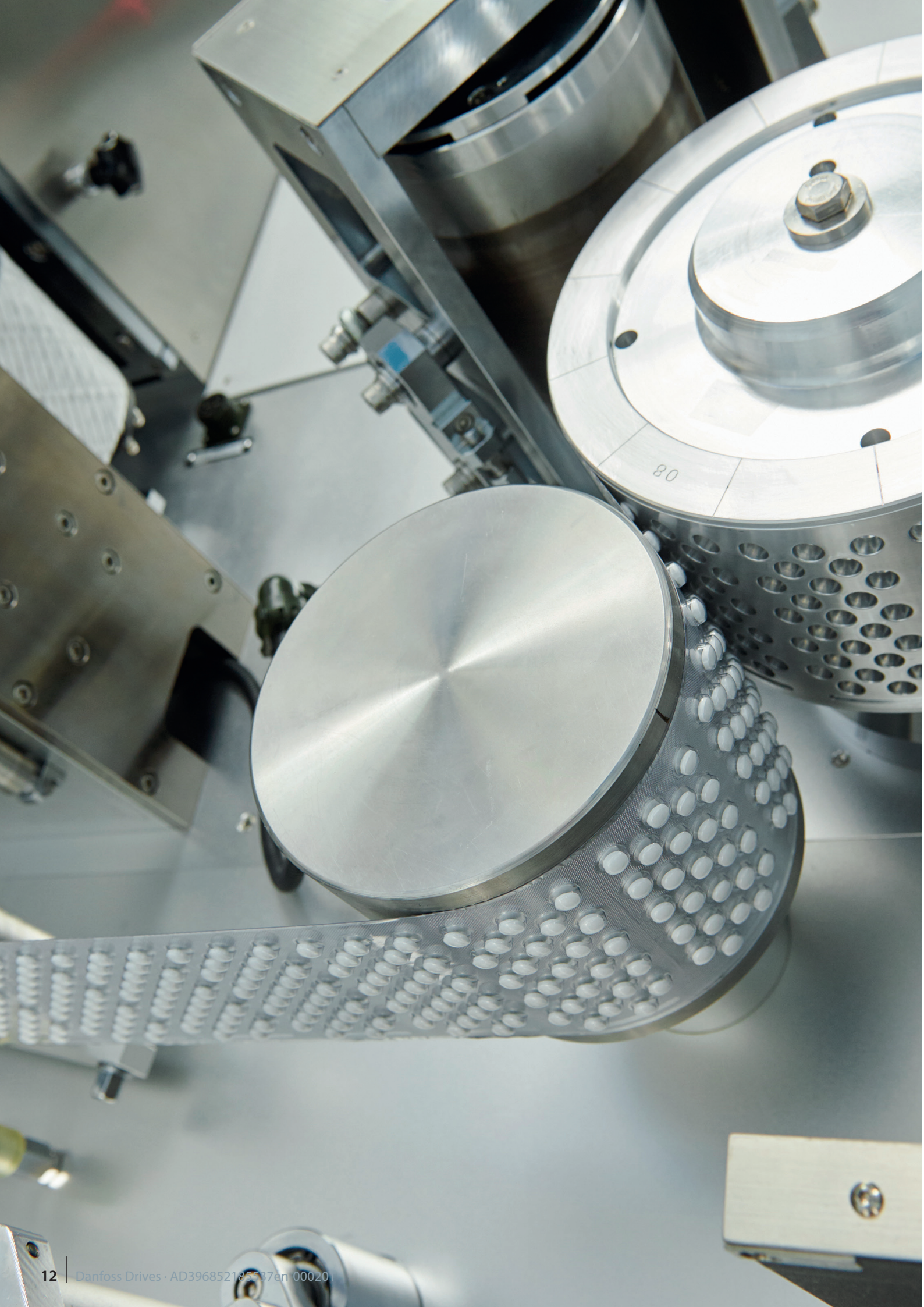

VLT® Decentral Access Module DAM 510



The DAM 510 module connects the VLT® Integrated Servo Drive ISD® 520 and VLT® Decentral Servo Drive DSD 520 through a hybrid feed-in cable to the MSD 510 system. This gives you great flexibility, the freedom to design the servo system according to your application needs and supports modular machine architectures.

Specifications

		DAM 510 15 A	DAM 510 25 A
Ordering number related to fieldbus variant	PROFINET®	175G0171	175G0174
	POWERLINK®	175G0169	175G0172
	EtherCAT®	175G0170	175G0173
DC-link	V DC	565-680 +/-10%	
Output current DC-link	A	15	25
Module width	mm [inch]	50 [1.97]	
Frame size		FS 1	
Weight	kg [lbs]	3.1 [6.8]	

VLT® Auxiliary Capacitors Module ACM 510



Connect the ACM 510 to the system to store energy. This allows you to make a controlled machine stop in emergency situations.

Specifications

ACM 510		
Ordering number per fieldbus variant	PROFINET®	175G0177
	POWERLINK®	175G0175
	EtherCAT®	175G0176
DC-link	V DC	565-680 +/-10%
Storable energy	J	max. 770
Module width	mm [inch]	50 [1.97]
Frame size		FS 1
Weight	kg [lbs]	3.1 [6.8]

VLT® Expansion Module EXM 510



To support a modular machine architecture the EXM 510 can be used to split the MSD 510 system into 2 cabinets. The max. distance between the cabinets (cable length) is 5 meters.

Specifications

EXM 510		
Ordering number		175G0194
DC-link	V DC	565-680 +/-10%
Maximum current DC-link	A	62
Module width	mm [inch]	50 [1.97]
Weight	kg [lbs]	0.6

VLT® Integrated Servo Drive ISD® 520

The VLT® Integrated Servo Drive ISD® 520 combines a servo motor and servo drive in one compact unit. It offers great benefits in diverse applications, such as turntables, labeling, capping, and packaging of food and pharmaceuticals.

The ISD 520 is supplied by a combination of the VLT® Power Supply Module PSM 510 and the VLT® Decentral Access Module DAM 510. The Plug and Twist hybrid cabling concept, including supply and control voltage as well as functional safety and fieldbus wires, makes the installation fast, easy, fail-safe and cost-efficient. Since multiple decentral drive units can be connected to just one VLT® Decentral Access Module DAM 510 through simple daisy-chain wiring, no distribution boxes are needed and cables can be reduced to a minimum.

A completely smooth and easy-to-clean surface together with high protection IP67 enclosure and vibration resistance class 3M7 ensure the perfect fit for all kinds of rotating applications in demanding environments.

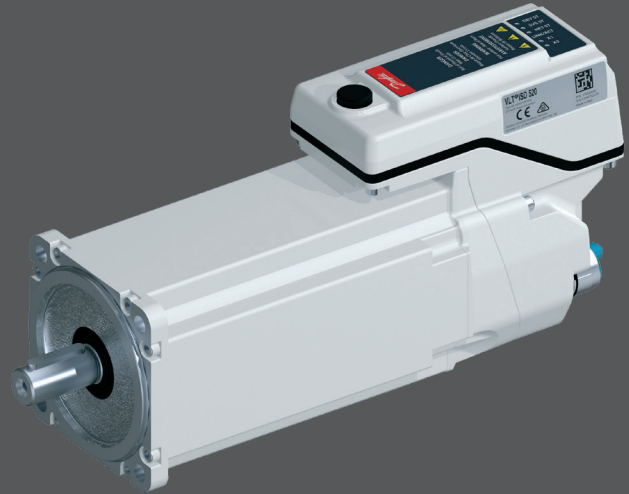

Specifications

		Size 1	Size 2	Size 3	Size 4	Size 5	
Low and high speed motors							
Flange size	mm [inch]	70	87	91	100	116	142
Shaft diameter	mm [inch]	11	19	14/19	19	24	24
Weight (without brake)	kg [lbs]	2.6	4.2	3.9-5.7	6.6...TBD	9.1-11.0	11.8-13.2
Inertia	10 ⁻⁴ kgm ²	0.63	2.3	0.80-1.80	2.60-3.20	5.10	9.80-12.9
Rated voltage	V DC	565-680 +/-10%					
Rated switching frequency	kHz	8/10					
Possible switching Frequency	kHz	4/5					
Auxiliary voltage	V DC	24/48					
Maximum auxiliary current ¹⁾	A DC	0.82	0.4	0.82-1.21	1.24	1.19-1.42	1.42
Low speed motors							
Rated speed	rpm	3000	2000	3000	3000	2200	2200
Max speed	rpm	6600	2500	6600	6600	6000	5000
Rated torque	Nm	1.65	2.5	2.5-4.6	5.2-6.4	9.0-11.2	10.6-13.8
Stall Torque	Nm	2.6	2.6	2.6-5.0	6.4-8.4	11.2	10.6-16.0
Peak Torque	Nm	6.3	11.0	7.5-15.5	16.0-25.6	29.0-32.0	33.0-39.0
Rated current	A DC	1.1	1.1	1.7-3.2	3.2-3.9	5.5-7.0	6.2-7.0
Peak current	A DC	6.2	6.0	7.6-12.5	12.5-22.0	22.0	22.0
High speed motors							
Rated speed	rpm	6000	N/A	6000	6000	4500	4500
Max speed	rpm	6600	N/A	6600	6600	6000	5000
Rated torque	Nm	Values available upon request ²⁾					
Stall torque	Nm						
Peak torque	Nm						
Rated current	A DC						
Peak current	A DC						

¹⁾ Value at auxiliary voltage 24 V DC, including mechanical holding brake

²⁾ Different rated speed ranges are available upon request

VLT® Decentral Servo Drive DSD 520

The VLT® Decentral Servo Drive DSD 520 extends the decentral servo drive concept. With rated power up to 2.3 kW and supporting a wide range of feedback encoders, its architecture is completely open and allows you to choose your preferred PM or ASM motor.

The DSD 520 is supplied by a combination of the VLT® Power Supply Module PSM 510 and the VLT® Decentral Access Module DAM 510. The Plug and Twist hybrid cabling concept, including supply and control voltage as well as functional safety and fieldbus wires, makes the installation fast, easy, fail-safe and cost-efficient. Since multiple decentral drive units can be connected to just one VLT® Decentral Access Module DAM 510 module through simple daisy-chain wiring, no distribution boxes are needed and you can reduce cabling to a minimum.

A completely smooth and easy-to-clean surface, together with high-protection IP67 enclosure and vibration resistance class 3M7, ensures the perfect fit for all kinds of rotating applications in demanding environments.



Specifications

DSD 520		
Rated voltage	V DC	565-680 +/-10%
Rated current I_N	A rms	4.5
Maximum current I_{max}	A rms	12.5
Rated power P_N	kW [hp]	2.3 [3.08]
Nominal switching frequency	kHz	8/10
Possible switching frequency	kHz	4/5
Protection rating		IP67
Weight	kg [lbs]	2.3

Accessories and options

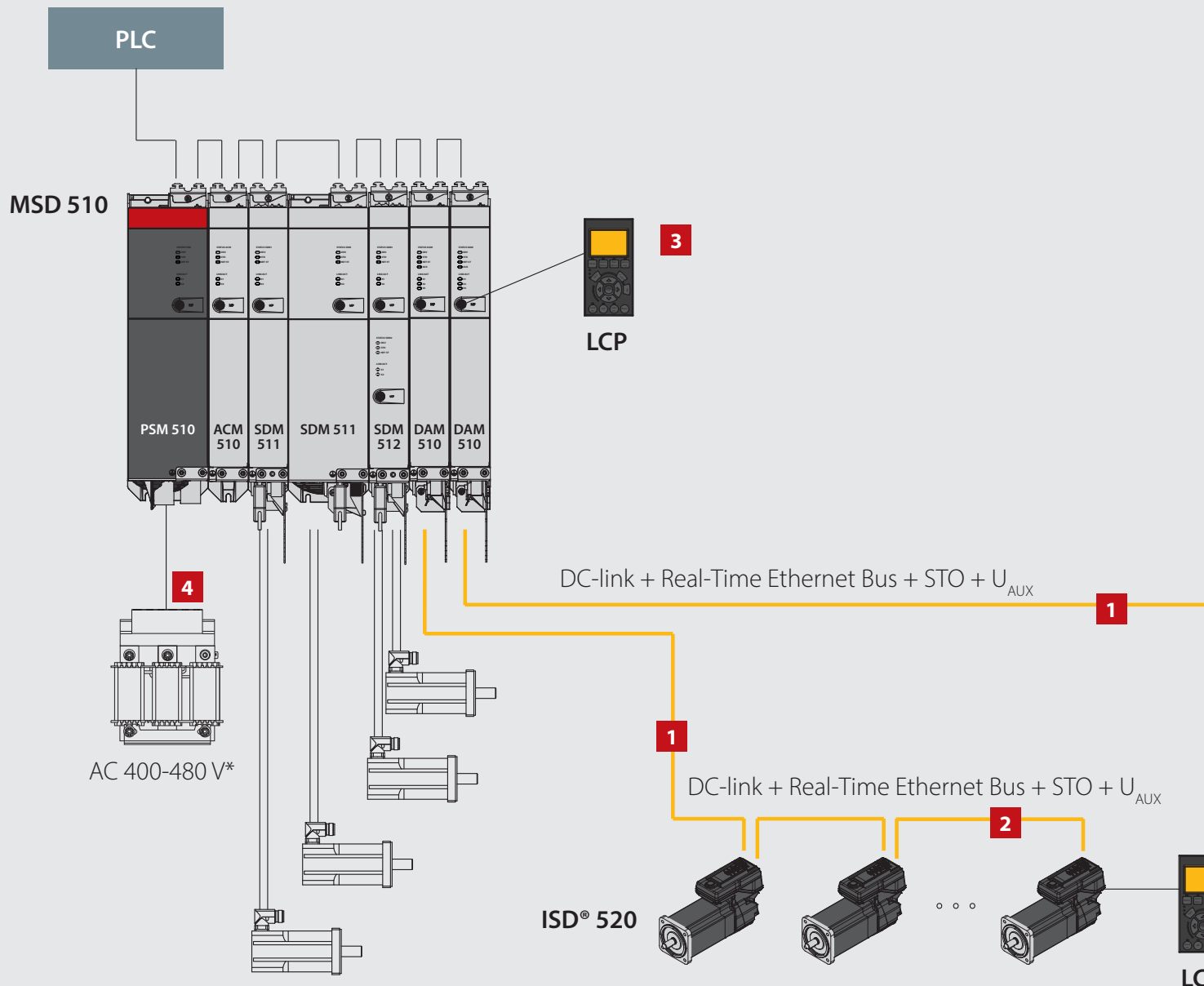

**It is mandatory to use a 3-phase AC line choke close to the PSM 510. For technical details please refer to the MSD 510 Operating Guide.*

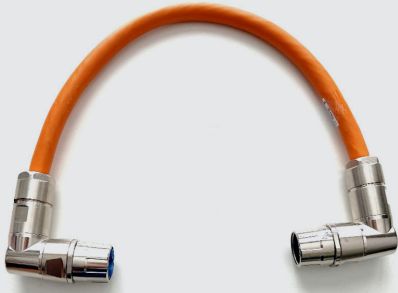

Loop cable M23 90° - M23 90°



Loop cable M23 180° - M23 180°



Feed-in cable Open - M23 90°



Feed-in cable Open - M23 180°



Feed-in cable DAM - M23 180°



Feed-in cable DAM - M23 90°

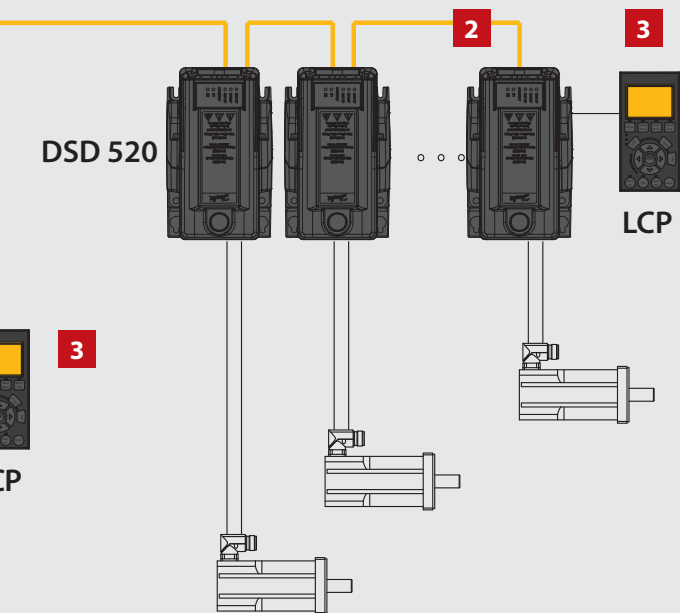

Fast, reliable and simple hybrid cables are available in numerous configurations and various lengths. Use feed-in cables to connect the DAM 510 with the first decentral drive in the line. Then use loop cables to continue the daisy chain from one ISD 520 or DSD 520 to the next. For flexibility as well as drag chain robustness, selected hybrid cable materials fulfill the individual application demands.

3 VLT® Local Control Panel LCP 102

Description	Ordering number
VLT® Local Control Panel LCP 102 (Graphical)	130B1107
LCP Cable (SUB-D to M8), 3 m [9.8 ft] cable	175G8942
LCP remote mounting kit (IP21) including LCP, fasteners, 3 m [9.8 ft] cable, and gasket	130B1170
LCP remote mounting kit (IP21) without LCP, but including fasteners, 3 m [9.8 ft] cable, and gasket	130B1117

4 AC line choke

Description	Ordering number
3 Phase Line Reactor 20A	175G0179
3 Phase Line Reactor 63A	175G0178
3 Phase Line Reactor 40A	175G0192



General-purpose **servo drive solution**

VLT® FlexMotion™ is a multi-purpose universally compatible servo drive concept, designed to meet the requirements of tomorrow's machine architecture, today.

Combine central and decentral drives for ultimate flexibility when it comes to machine design and system integration. The smart platform concept ensures identical user interfaces and makes installation, programming and maintenance

quick and easy. The modular system even facilitates trouble-free machine extensions or adaptations at a later stage.

Open connectivity to common real-time Ethernet systems, IEC 61131-3-based programming and PLCopen® Motion Function Blocks makes the system even more versatile and easy to integrate into diverse engineering environments.



Discover more about VLT® FlexMotion™ here:
drives.danfoss.com/flexmotion

Follow us and learn more about AC drives



VLT® | VAGON®

Any information, including, but not limited to information on selection of product, its application or use, product design, weight, dimensions, capacity or any other technical data in product manuals, catalogues descriptions, advertisements, etc. and whether made available in writing, orally, electronically, online or via download, shall be considered informative, and is only binding if and to the extent, explicit reference is made in a quotation or order confirmation. Danfoss cannot accept any responsibility for possible errors in catalogues, brochures, videos and other material. Danfoss reserves the right to alter its products without notice. This also applies to products ordered but not delivered provided that such alterations can be made without changes to form, fit or function of the product. All trademarks in this material are property of Danfoss A/S or Danfoss group companies. Danfoss and the Danfoss logo are trademarks of Danfoss A/S. All rights reserved.